

**D25, DH25 and DHR25 Series, Rated up to 100 Amps,  
115/200 VAC, 400 Hz**

**Product Facts**

- 3PDT NO
- Gasket sealed or Hermetically sealed
- Auxiliary contacts available
- Meets many requirements of MIL-PRF-6106

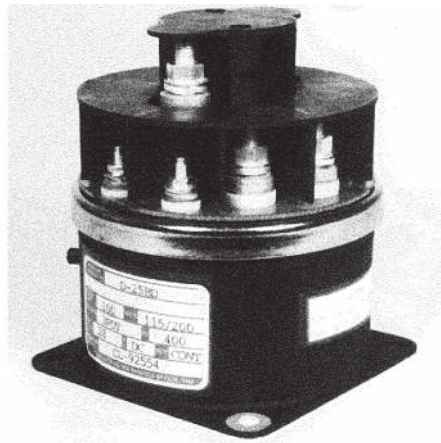

**Performance Data**

**Electrical Characteristics**

- Contact Arrangement** — 3PDT NO
- Rated Operating Voltage** — 115/200 VAC, 400 Hz, 3 phase
- Resistive Rating** — 100 Amps
- Inductive Rating** — 100 Amps

**General Characteristics**

- Temperature Range** — -55°C to +85°C
- Operating Cycles (Life) at Rated Resistive Load, Min.** — 50,000 cycles
- Operating Cycles (Life) Mechanical, Min.** — 100,000 cycles
- Dielectric Strength** — All Circuits to Ground — 1,500 Vrms  
Circuit to Circuit — 1,500 Vrms  
Coil to Ground and Aux. Contacts — 1,000 Vrms
- Insulation Resistance, Initial** — 100 megohm min.
- Altitude** — D-25 — 50,000 ft.  
DH-25, DHR-25 — 80,000 ft.
- Weight, Max.** — 2.20 to 2.75 lbs
- Sinusoidal Vibration** — 10 G @ 70 to 2,000 Hz
- Shock, Max.** — 25 G
- Operate Time @ Nom. Voltage, Max.** — 35 msec
- Release Time @ Nom. Voltage, Max.** — 35 msec
- Bounce Time @ Nom. Voltage, Max.** — 5 msec

**Coil Characteristics**

- Duty Cycle** — VAC 400 Hz — AC (Type A, See diagram below)  
Vdc — Continuous (Type B, See diagram below)  
Vdc — Continuous with suppression (Type C, See diagram below)
- Operating Voltage, Nom.** — VAC 400 Hz — 115 VAC  
Vdc — 28 Vdc
- Pickup Voltage @ 25°C, Max.** — VAC 400 Hz — 103.5 VAC  
Vdc — 18 Vdc
- Dropout Voltage @ 25°C, Max.** — VAC 400 Hz — 5 to 45 VAC  
Vdc — 1.5 to 7 Vdc
- Coil Resistance ±20% @ 25°C** — VAC 400 Hz — N/A  
Vdc — 175 Ohms

**Coil Type**

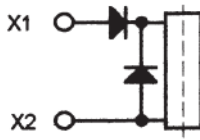

A — AC

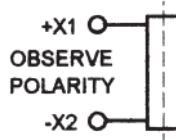

B — Continuous

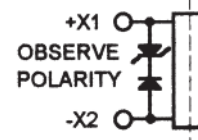

C — Continuous with Suppression

For factory-direct application assistance, phone 419-521-9500 or fax 419-526-2749.

**D25, DH25 and DHR25 Series, Rated up to 100 Amps,  
115/200 VAC, 400 Hz (Continued)**

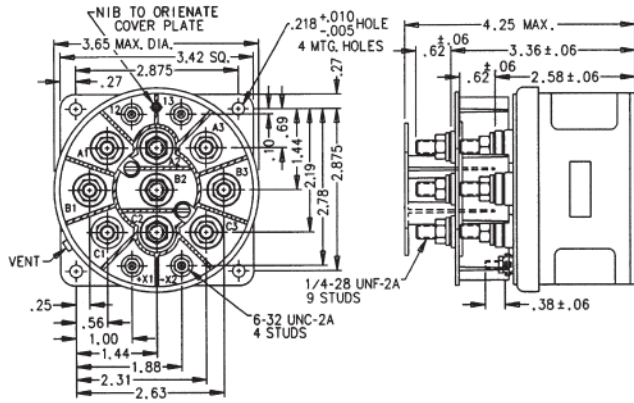

Mounting Style A

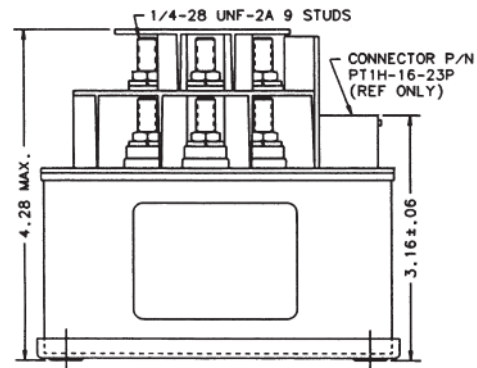
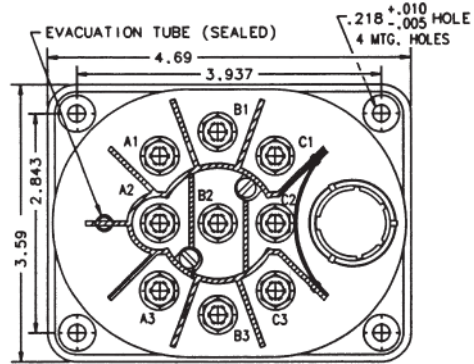

Mounting Style B

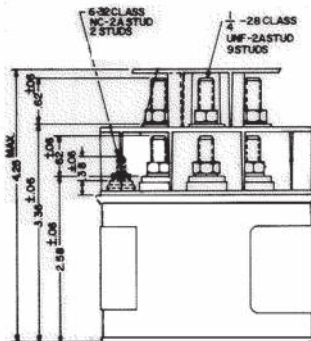
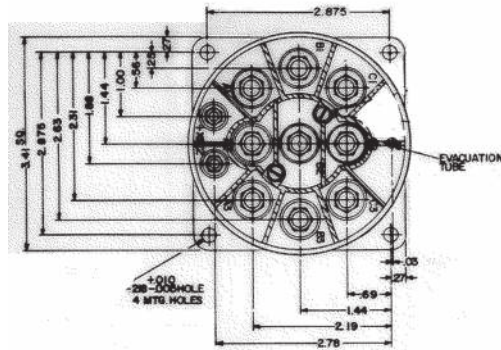

Mounting Style C

For factory-direct application assistance, phone 419-521-9500 or fax 419-526-2749.

**D25, DH25 and DHR25 Series, Rated up to 100 Amps,  
115/200 VAC, 400 Hz (Continued)**

**Circuit Configurations** (Consult factory for other available circuit configurations)

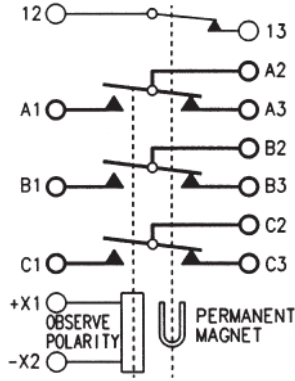

Circuit Configuration 1

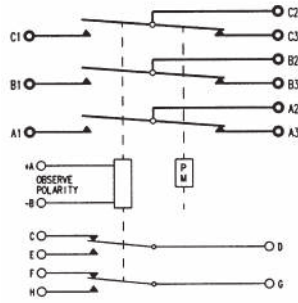

Circuit Configuration 2

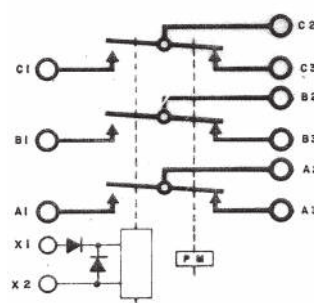

Circuit Configuration 3

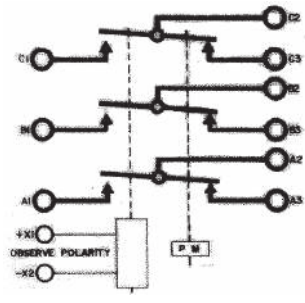

Circuit Configuration 4

HARTMAN Part Number	Construction Type	Mounting Style	Coil Type	Circuit Config.	TE Part Number
D-25BD	Gasket/Vented	A	B	1	1616034-3
DH-25B	Hermetically Sealed	C	B	4	1616037-2
DH-25BA	Hermetically Sealed	B	B	2	1616037-3
DHR-25BG	Hermetically Sealed	A	A	3	1-1616037-5

For factory-direct application assistance, phone 419-521-9500 or fax 419-526-2749.