

GENERAL DESCRIPTION

The SP7616 is a 30V 4-Channel linear low side LED driver. It is capable of powering up to four LED strings of nine LEDs @ 60mA per string for a total of 36 LEDs with 1.5% typical current matching between channels. The desired LED current can be adjusted with an external resistor, and the precision string-to-string current matching ensures consistent color temperature across the whole display. The device also features very low dropout voltage to maximize system efficiency and avoid difficult thermal design constraints. Dimming can be achieved by feeding a PWM signal to the PWM pin, or use an analog signal to control the ISET current, this allows brightness control without unwanted color shifts. Fast LED current turn-on/off time allows up to 5 kHz PWM dimming frequencies with as low as 10% duty cycle, completely eliminating flicker. The built-in thermal protection prevents damage to the device under fault conditions.

APPLICATIONS

- CCFL replacement in TFT displays
- Panel backlighting
- Casino gaming light systems
- Advertising backlighting

FEATURES

- Wide 4.5V to 30V operating range
- 60mA LED current per channel
- 1.5% channel to channel current matching
- Analog Dimming control
- PWM operation up to 5kHz with 10% Duty Cycle
- Low dropout: 150mV @ 20mA
- Built-in Over Temperature Protection
- Small 2X3mm DFN package
 - Lead Free, RoHS Compliant

TYPICAL APPLICATION DIAGRAM

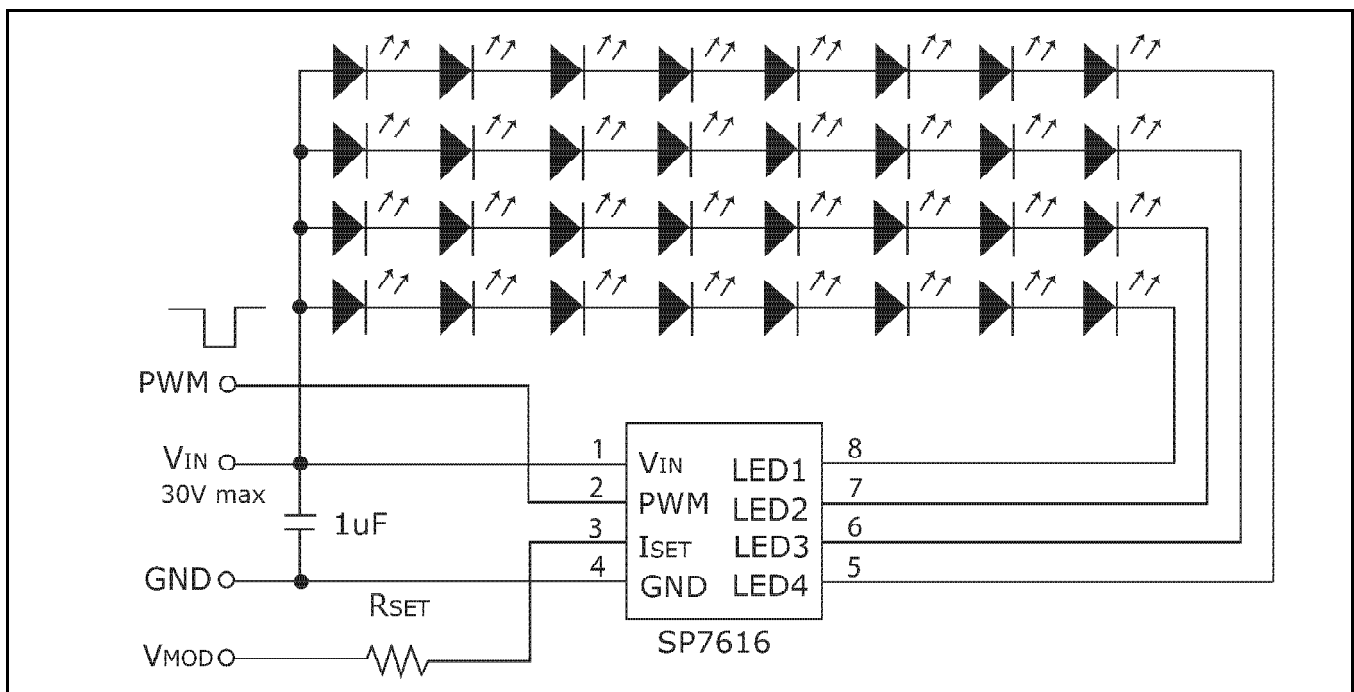

Fig. 1: SP7616 Application Diagram



SP7616

High Accuracy 4-Channel Low Side LED Driver for CCFL Replacement

ABSOLUTE MAXIMUM RATINGS

These are stress ratings only and functional operation of the device at these ratings or any other above those indicated in the operation sections of the specifications below is not implied. Exposure to absolute maximum rating conditions for extended periods of time may affect reliability.

V_{IN} -0.3V to 32V
 LED1, LED2, LED3, LED4 -0.3V to 32V
 I_{SET} , PWM -0.3V to 6.0V
 Storage Temperature..... -65°C to 150°C
 Power Dissipation Internally Limited
 Lead Temperature (Soldering, 10 sec) 300°C

OPERATING RATINGS

Input Voltage Range V_{IN}4.5V to 30V
 Junction Temperature Range-40°C to 100°C
 Thermal Resistance θ_{JA} 59°C/W
 ESD Rating (HBM - Human Body Model) 2kV
 ESD Rating (MM - Machine Model)..... 500V
 Operating Junction Temperature -40°C to +125°C
 Power Dissipation.....Internally Limited

ELECTRICAL SPECIFICATIONS

Specifications with standard type are for an Operating Junction Temperature of $T_J = 25^\circ\text{C}$ only; limits applying over the full Operating Junction Temperature range are denoted by a “•”. Minimum and Maximum limits are guaranteed through test, design, or statistical correlation. Typical values represent the most likely parametric norm at $T_J = 25^\circ\text{C}$, and are provided for reference purposes only. Unless otherwise indicated, $V_{IN} = 4.5\text{V}$ to 30V , $C_{IN} = 1\mu\text{F}$, $T_J = -40^\circ\text{C}$ to 125°C .

Parameter	Min.	Typ.	Max.	Units	Conditions
Operating Input Voltage Range	4.5		30	V	•
Shutdown Supply Current		30	60	μA	Voltage at I_{SET} is pulled to 3V V_{IN} 30V
Quiescent Supply Current		350	500	μA	No LED connected, V_{LED} pins are tied to GND. $R_{SET}=1\text{M}\Omega$
Quiescent Supply Current		1	1.5	mA	$I_{LED} = 30\text{mA}$
Quiescent Supply Current		1.5	3	mA	$I_{LED} = 60\text{mA}$
LED Current Matching	-3	0.5	3	%	• Relative to average of all 4 channels
LED Current Line Regulation		0.1	1	%/V	$V_{LED} = 0.5\text{V}$ to 25V , $V_{IN} = 28\text{V}$, $R_{SET} = 50\text{k}\Omega$
Line Regulation		0.05	0.1	% / V	$V_{IN} = 4.5\text{V}$ to 25V , $V_{LED}=0.5\text{V}$ (Note 2)
Maximum LED Current per channel		60		mA	$R_{SET} = 17.4\text{k}\Omega$,
LED Leakage Current			2	μA	PWM pin LOW, $V_{LED} = 1\text{V}$, $V_{IN}= 5\text{V}$
Dropout Voltage		0.30	0.45	V	(Note 3)
Output Current Multiplication Ratio $K = I_{LED} \cdot R_{SET}$	1032	1075	1118		$I_{LED} = 30\text{mA}$, $R_{SET}=35.833\text{k}\Omega$, • $0^\circ\text{C} \leq T_J \leq 125^\circ\text{C}$
I_{SET} Voltage		1		V	
Thermal Shutdown Die Temperature		150		$^\circ\text{C}$	$I_{LED} = 0\text{mA}$. LED current will self recover when temperature drops below the trip point, minus thermal shut down hysteresis.
Thermal Shutdown Hysteresis		15	20	$^\circ\text{C}$	
PWM Pin Logic LOW			0.8	V	Driver is disabled
PWM Pin Logic HIGH	2.4		5.5	V	Driver is active
PWM pin Hysteresis		400		mV	
I_{SET} Shutdown Threshold			3	V	• If I_{SET} is pulled above this threshold the device goes into full shutdown
I_{SET} Shutdown Threshold Hysteresis		0.3		V	
Typical PWM Maximum Dimming Frequency			5	kHz	Applied to PWM pin. See typical performance curves.
Typical PWM Dimming Duty Cycle Range	10		90	%	Applied to PWM pin @ 5kHz. See typical performance curves.



SP7616

High Accuracy 4-Channel Low Side LED Driver for CCFL Replacement

Parameter	Min.	Typ.	Max.	Units	Conditions
Turn-on time from Shutdown		100	300	μs	V_{MOD} from 5V to 0V, $R_{\text{SET}} = 50\text{k}\Omega$
Turn-off time into Shutdown			20	μs	V_{MOD} from 0V to 5V, $R_{\text{SET}} = 50\text{k}\Omega$

Note 1: I_{LED} Variations from specified by R_{SET} value at V_{LED} changing from 0.5 to 25V

Note 2: I_{LED} Variations from specified by R_{SET} value at V_{IN} changing from 4.5 to 25V

Note 3: $R_{\text{SET}} = 31.6\text{k}\Omega$: Dropout voltage is measured as the V_{LED} voltage where LED current drops 5% from nominal value

BLOCK DIAGRAM

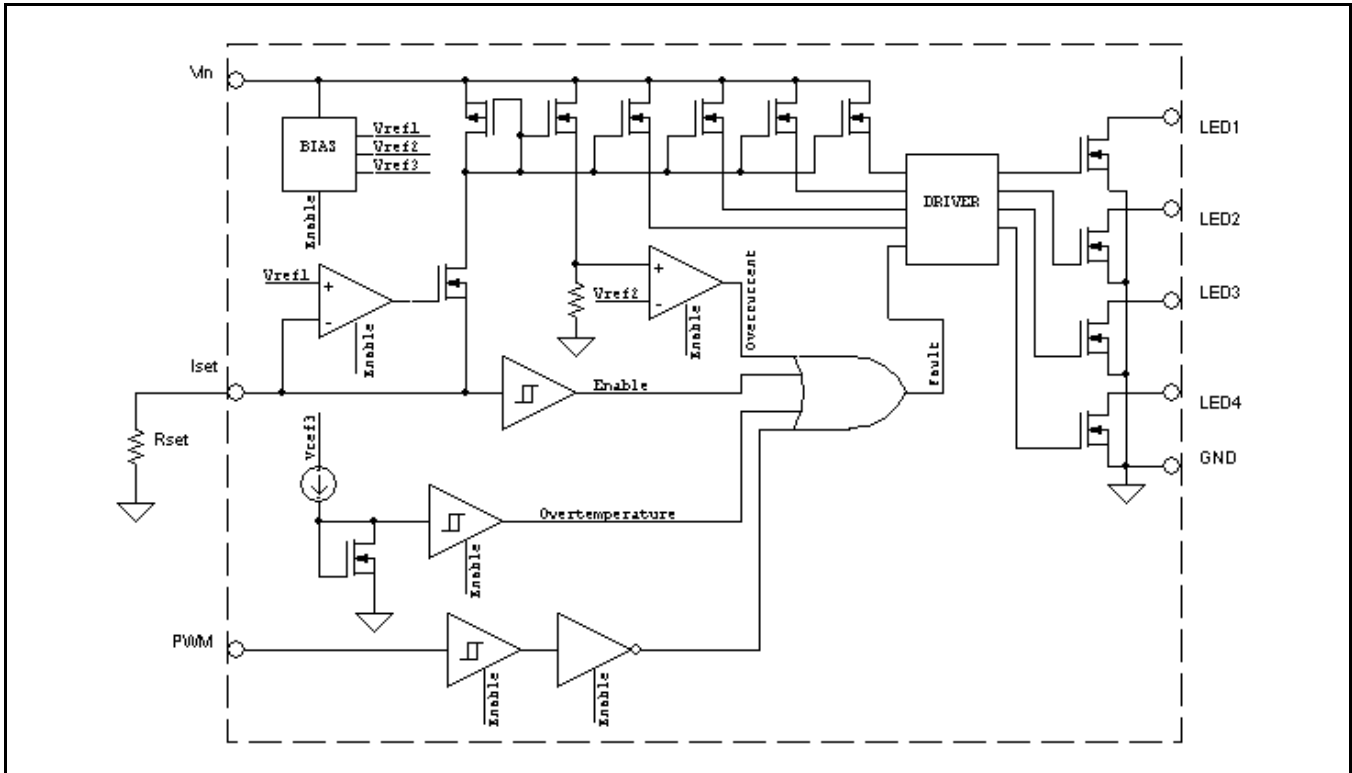

Fig. 2: SP7616 Block Diagram



SP7616

High Accuracy 4-Channel Low Side LED Driver for CCFL Replacement

PIN ASSIGNMENT

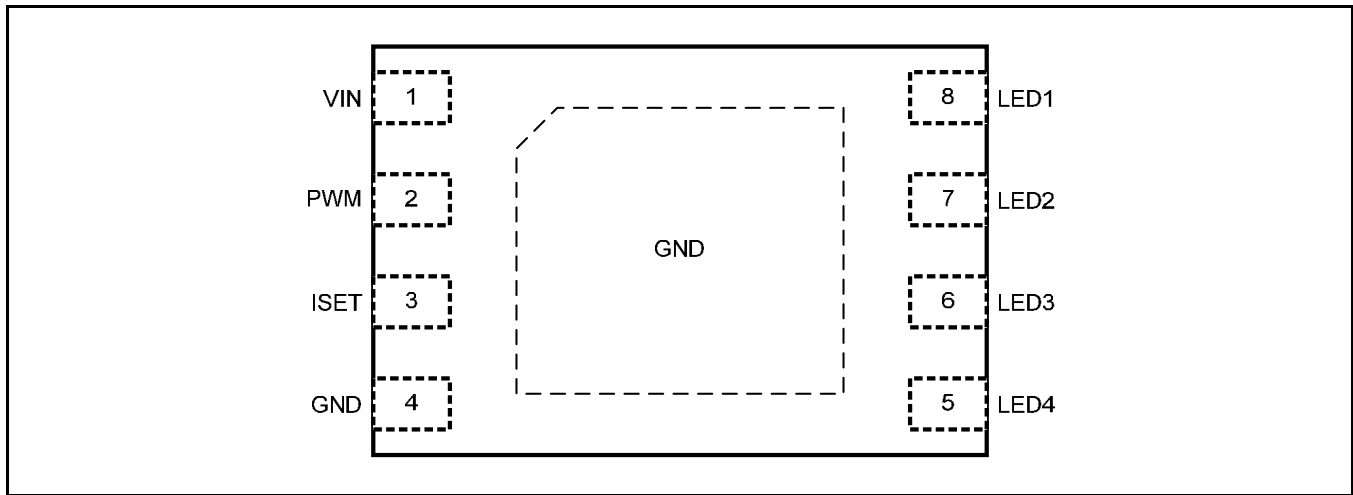

Fig. 3: SP7616 Pin Assignment

PIN DESCRIPTION

Name	Pin Number	Description
VIN	1	Input voltage for the IC. Connect a 1uF decoupling capacitor between this pin and ground.
PWM	2	This pin must be held high to enable the output drivers. It can be used for PWM dimming up to 5 kHz.
ISET	3	Connect resistor RSET from this pin to ground to set output current. Pulling this pin above the shutdown threshold stated in the Electrical Specifications puts the IC into shutdown mode.
GND	4	Ground return for LED currents and circuitry of the SP7616.
LED1-4	5 - 8	Connect an LED between each pin and V_{IN} . Current value is controlled by RSET. The current level through each pin is internally matched within 3%. Connect unused channel(s) to GND to save current consumption.

ORDERING INFORMATION

Part Number	Temperature Range	Marking	Package	Packing Quantity	Note 1	Note 2
SP7616ER-L	$-40^{\circ}\text{C} \leq T_j \leq +125^{\circ}\text{C}$		8pin 2x3DFN	Bulk	Lead Free and/or Halogen Free	
SP7616ER-L/TR	$-40^{\circ}\text{C} \leq T_j \leq +125^{\circ}\text{C}$		8pin 2x3DFN	3K/Tape & Reel	Lead Free and/or Halogen Free	
SP7616EB	SP7616 Evaluation Board					

"YY" = Year - "WW" = Work Week - "X" = Lot Number



TYPICAL PERFORMANCE CHARACTERISTICS

All data taken at $V_{IN} = 8V$, $T_J = T_A = 25^\circ C$, unless otherwise specified.

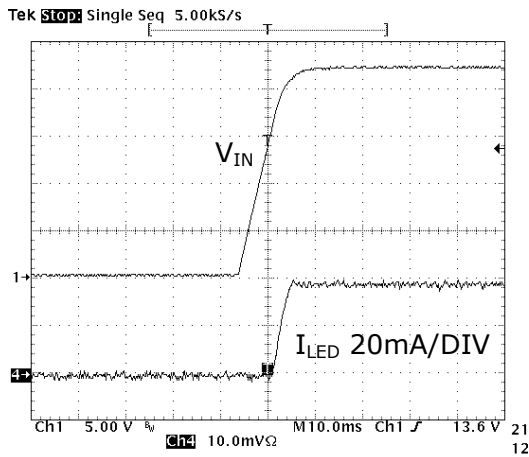

Typical Turn on Characteristics

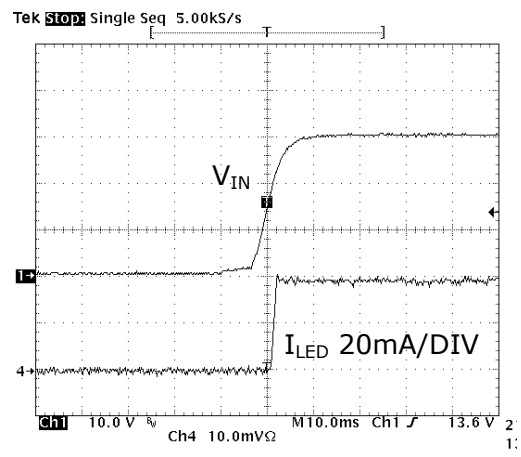

Typical Turn Maximum Input Voltage

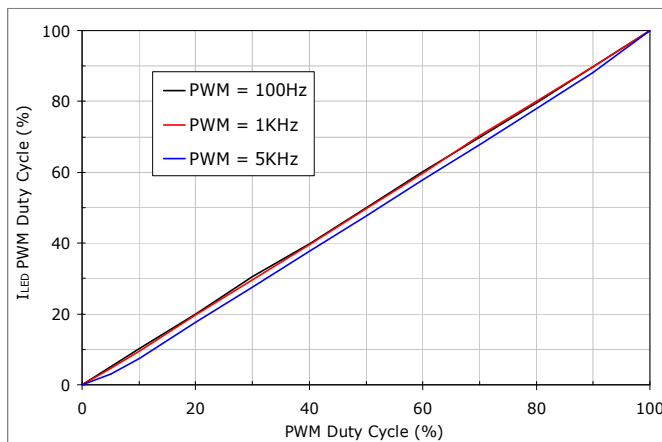

PWM Duty Cycle Linearity

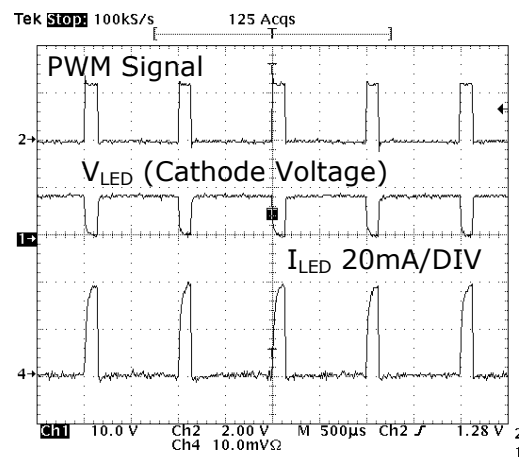

PWM Response 1kHz 10% Duty Cycle

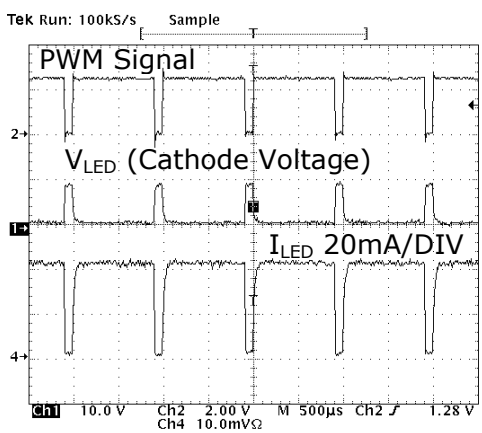

PWM Response 1kHz 90% Duty Cycle

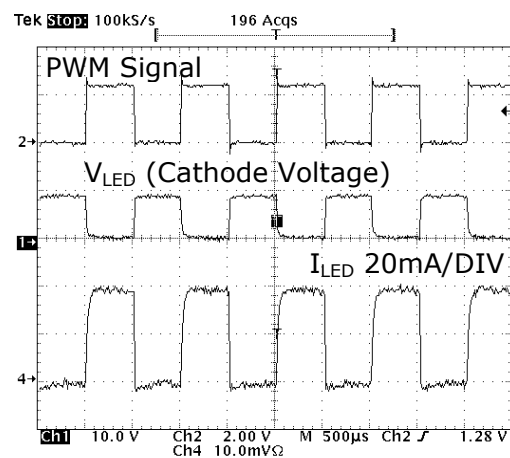

PWM Response 1kHz 50% Duty Cycle



SP7616

High Accuracy 4-Channel Low Side LED Driver for CCFL Replacement

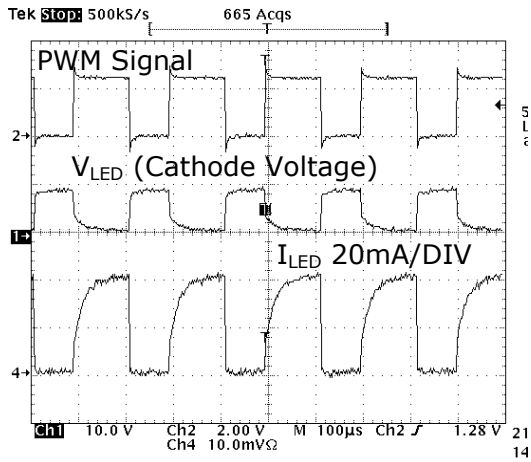

PWM Response 5kHz 50% Duty Cycle

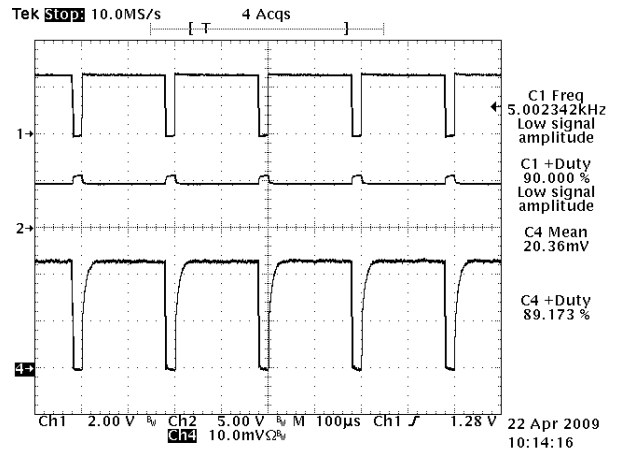

PWM Response 5kHz 90% Duty Cycle

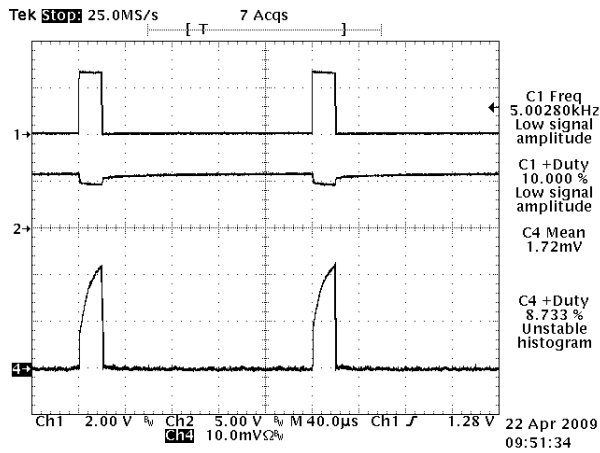

PWM Response 5kHz 10% Duty Cycle

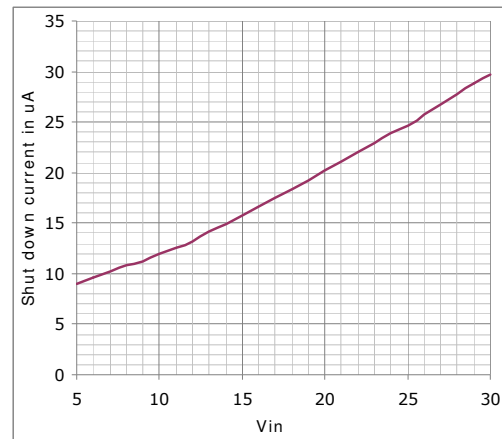

Typical Shutdown Current vs Input Voltage

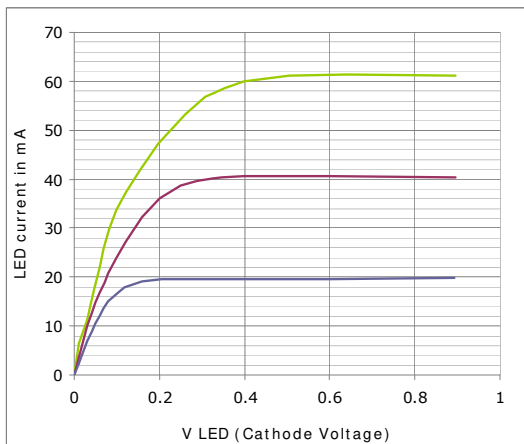

Typical Dropout Performance

THEORY OF OPERATION

INTRODUCTION

The SP7616 is a four-channel constant current source LED driver with programmable output current level. The design consists of a regulator reference voltage source, current amplifier, and output driver. The precision reference voltage ensures good performance over voltage and temperature. The four outputs are tightly coupled allowing for excellent LED current matching.

SETTING LED CURRENT

The current in the LED strings is set by adjusting the R_{SET} resistor connected between the I_{SET} pin and ground. The LED current is set using the following the following equation.

$$I_{LED} = \frac{K}{R_{SET}} mA$$

Where:

K = Output Current Multiplication Ratio

I_{LED} is the desired LED current

PWM DIMMING

The LED dimming control is done through the PWM pin. The acceptable frequency range of this signal is 100Hz to 5kHz. The acceptable duty cycle range of the signal is 10% to 90% at 1KHZ. When the PWM pin is driven low, only the LED current sources are disabled while the rest of the chip is still enabled.

ANALOG DIMMING CONTROL

Besides digital PWM control, the LED current can be controlled continuously (from high to low LED current) by raising the voltage at the bottom of R_{SET} , V_{MOD} , from 0.0V to 1V maximum. This configuration is shown in figure 1 below.

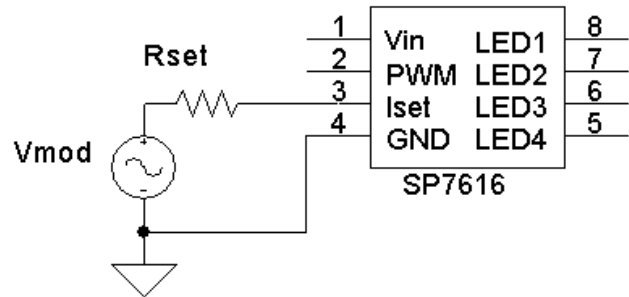

Figure 1

The R_{SET} value may be determined from the previous equation for $V_{MOD} = 0V$. The equation below shows the effect of using a V_{MOD} in the circuit on the LED current.

$$I_{LED} \approx (1V - V_{MOD}) \frac{K}{R_{SET}} mA$$

Where:

1V = Typical I_{SET} Voltage

K = Output Current Multiplication Ratio

I_{LED} is the desired LED current

V_{MOD} is the adjustment voltage

Note that this method of current control is not as precise as adjusting R_{SET} . The voltage at the I_{SET} pin is adjusted slightly during manufacturing to ensure that K, the output current multiplication ratio, is as accurate as possible. When the SP7616 was originally released at the end of 2006, the multiplication ratio and I_{SET} voltage were specified separately. However, market feedback for better accuracy when using R_{SET} alone prompted the change to the way the part is specified today.

SHUTDOWN USING I_{SET} PIN

In normal operation, the voltage at I_{SET} pin is around 1V. To ensure fast turn on at low duty cycle and high PWM frequency, only the output drivers are switching in PWM mode. However, the whole chip can be shutdown by pulling the voltage at I_{SET} above 3V minimum.



SP7616

High Accuracy 4-Channel Low Side LED Driver for CCFL Replacement

V_{IN} CONSIDERATIONS (IMPORTANT)

The V_{IN} pin of the SP7616 (Pin 1) needs to be connected to the anode of the LED for proper operation. If these are not tied together, the part can get into a latch condition as a result of improper sequencing.

A second way the part can get into a latch condition is if the input voltage falls below 1.5V but does not fall below 0.5V before the power is re-applied.

In both cases, the latch condition can be "reset" by pulling the input voltage below 0.5V for >3 seconds. This latch is similar to what one might experience with a uC if a reset was not asserted after a brown out condition.

UNUSED CHANNELS AND LED 2 CHANNEL (PIN 7)

LED 2 channel should never be grounded or left unconnected it should always be used during operation. Other unused channels can be tied to the ground to save on power consumption.

SHORTED LEDs

If all LEDs on a string are shorted, the LED cathode voltage will be V_{IN}. It is still a working condition for this device but it significantly increases the dissipated power.

At 20mA LED current and V_{IN} = 30V additional power dissipated in the package is equal to 600mW that will increase die temperature to 59°C/W x 0.6W = 35.4C, where 59°C/W is the package thermal resistance. Assuming that all other channels are working at V_{LED} = 1.5V the die temperature will be approximately 41°C above ambient temperature and that decreases operating temperature range. Also to protect the part if too many LEDs are shorted, and the V_{LED} voltage becomes too high, making the part dissipates too much power, the over temperature protection will shut the part off when the die temperature reaches approximately 150°C.

OVER-TEMPERATURE PROTECTION

The SP7616 has over-temperature protection to prevent permanent damage to the device. When the die temperature rises above 150°C the output drivers are shut off. The output current will self recover when the temperature drops below the trip point with the preset hysteresis of 15°C. Thus a part that shut off at 150°C will not try to restart unless the die temperature is below 135°C

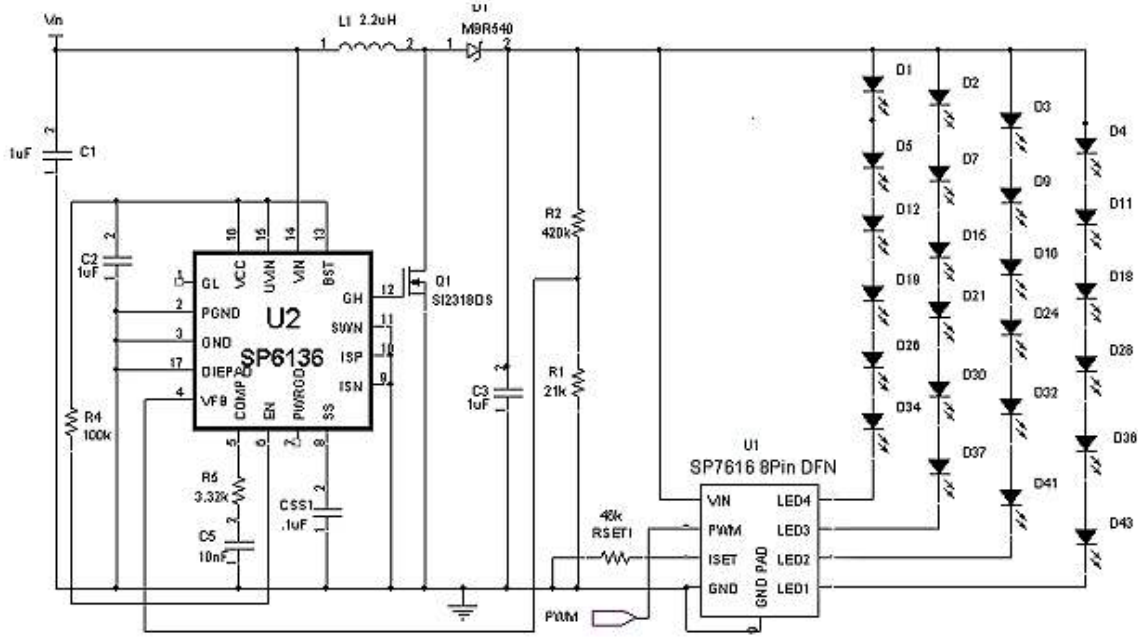

Figure 2
Typical Application: CCFL Replacement powered from 3 Li-ion batteries.

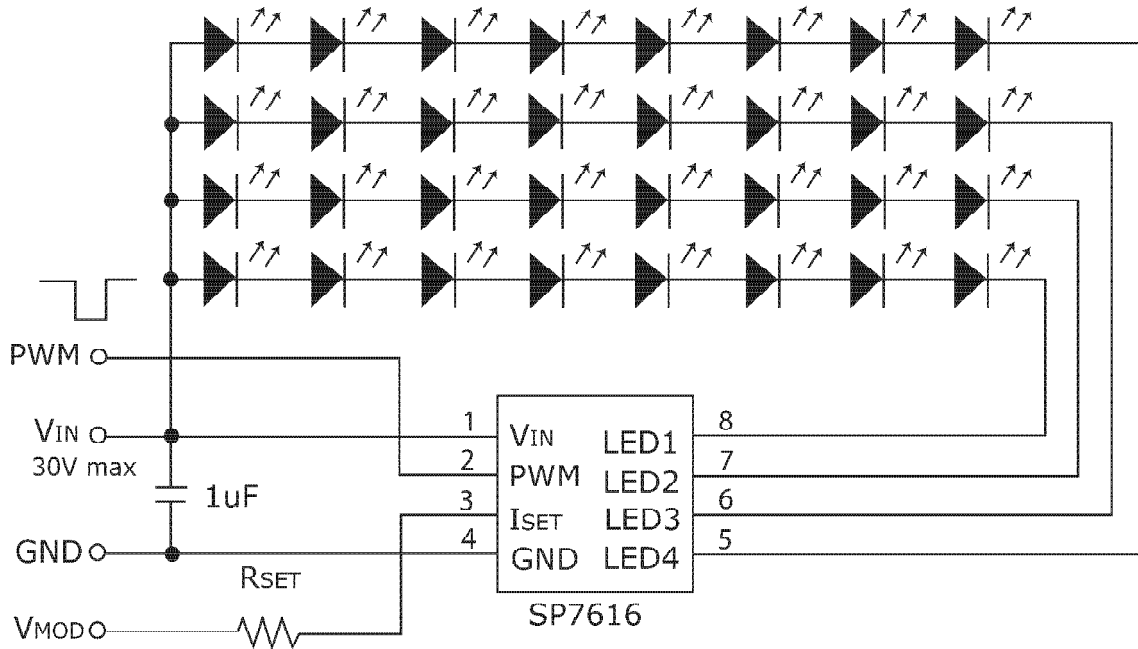

Figure 3
Using the SP7616 from a fixed source



SP7616

High Accuracy 4-Channel Low Side LED Driver for CCFL Replacement

PACKAGE SPECIFICATION

8PIN 2X3mm DFN

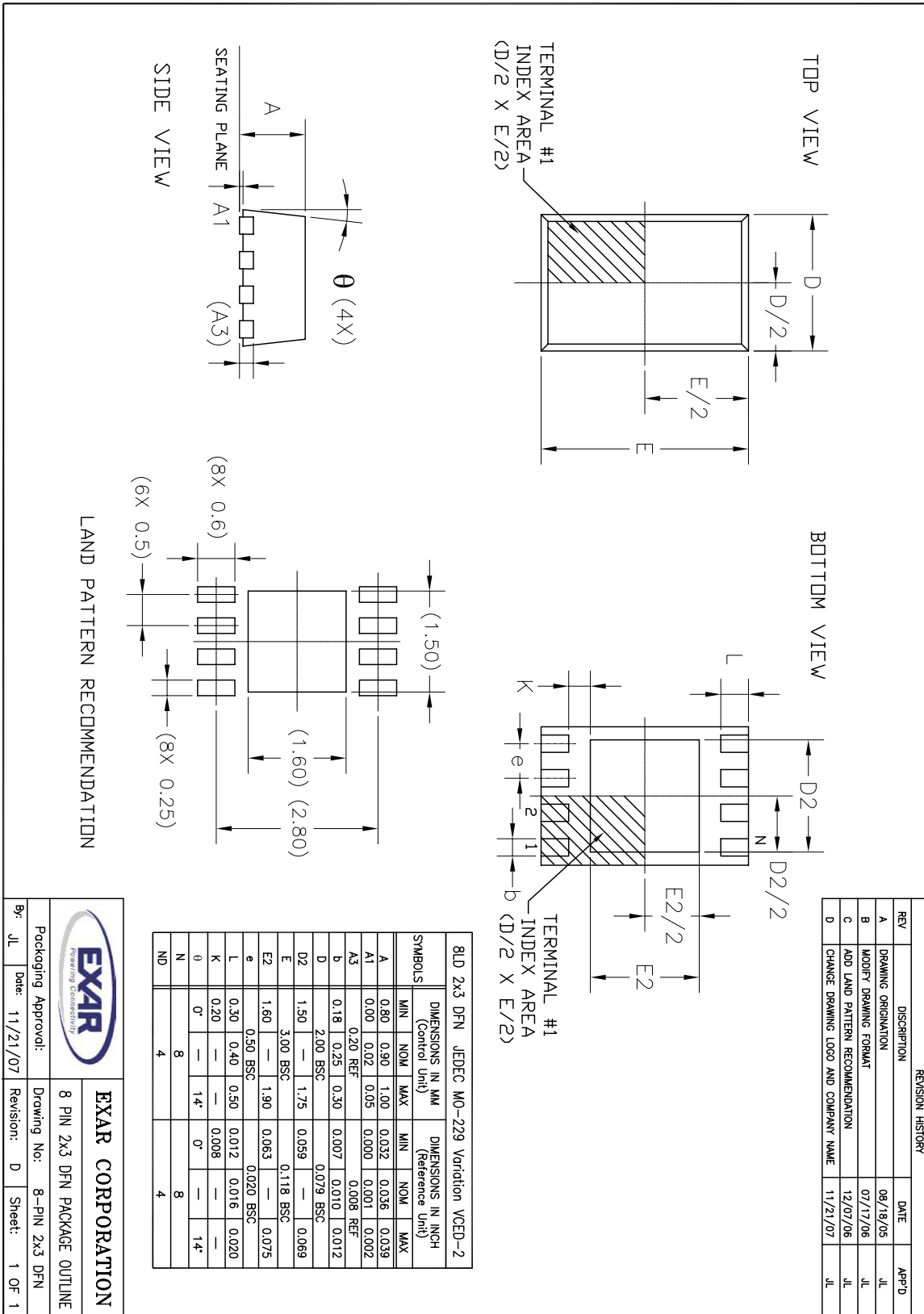

REVISION HISTORY			
REV	DISCRIPTION	DATE	APP'D
A	DRAWING ORIGINATOR	08/18/05	JL
B	MODIFY DRAWING FORMAT	07/17/06	JL
C	ADD LAND PATTERN RECOMMENDATION	12/07/06	JL
D	CHANGE DRAWING LOGO AND COMPANY NAME	11/21/07	JL

		EXAR CORPORATION	
Packaging Approval:		Drawing No: 8-PIN 2x3 DFN PACKAGE OUTLINE	
By: JL	Date: 11/21/07	Revision: D	Sheet: 1 OF 1



SP7616

High Accuracy 4-Channel Low Side LED Driver for CCFL Replacement

REVISION HISTORY

Revision	Date	Description
2.0.4	May 22, 2009	Reformat. Increased shutdown current to 60uA. Changed specification methodology for setting LED current. Multiplier value changed to 1075 typical. Changed room and over temp limits. Dropout voltage changed to 300mV typical, 450mV maximum. Added additional information in applications "V _{IN} Considerations" section. Updated resistor values for Maximum LED current per channel specification and current multiplication ratio. Changed PWM frequency and PWM duty cycle to typicals and referred to new curves in the typical performance graph section.

FOR FURTHER ASSISTANCE

Email: customersupport@exar.com
Exar Technical Documentation: <http://www.exar.com/TechDoc/default.aspx?>



EXAR CORPORATION
HEADQUARTERS AND SALES OFFICES
48720 Kato Road
Fremont, CA 94538 – USA
Tel.: +1 (510) 668-7000
Fax: +1 (510) 668-7030
www.exar.com

NOTICE

EXAR Corporation reserves the right to make changes to the products contained in this publication in order to improve design, performance or reliability. EXAR Corporation assumes no responsibility for the use of any circuits described herein, conveys no license under any patent or other right, and makes no representation that the circuits are free of patent infringement. Charts and schedules contained here in are only for illustration purposes and may vary depending upon a user's specific application. While the information in this publication has been carefully checked; no responsibility, however, is assumed for inaccuracies.

EXAR Corporation does not recommend the use of any of its products in life support applications where the failure or malfunction of the product can reasonably be expected to cause failure of the life support system or to significantly affect its safety or effectiveness. Products are not authorized for use in such applications unless EXAR Corporation receives, in writing, assurances to its satisfaction that: (a) the risk of injury or damage has been minimized; (b) the user assumes all such risks; (c) potential liability of EXAR Corporation is adequately protected under the circumstances.

Reproduction, in part or whole, without the prior written consent of EXAR Corporation is prohibited.