

2589-ID-10

**NOTES:**

1. THESE MOUNTING CLIPS ARE FOR HOLDING THE 2481 SERIES HOUSINGS TO THE MAIN PANEL TOPS OF ELECTRIC RANGES.
2. SCREW SIZE INDICATION.
3. .015/(.38) MAXIMUM CUT OFF.
4. .010/(.25) MAXIMUM MISMATCH.
5. THREAD FORM FOR A #10-32 SCREW.
6. THIS SURFACE MAY BE FORMED IN THIS DIRECTION A MAXIMUM OF 5°.

**MATERIAL:**

STEEL, STAINLESS, TYPE 301, .020/(.51) THICK.

THIS DRAWING CONTAINS INFORMATION THAT IS PROPRIETARY TO MOLEX ELECTRONIC TECHNOLOGIES, LLC AND SHOULD NOT BE USED WITHOUT WRITTEN PERMISSION									
SYMBOLS		DIMENSION UNITS		SCALE		CURRENT REV DESC: IMPORT TO NX			
∇ = 0	IN/MM	2:1		EC NO: 608062 DRWN: SALHAMY 2018/11/21 CHK'D: MKIPPER 2018/11/21 APPR: FSMITH 2018/11/21 INITIAL REVISION: DRWN: RHR 11/20/92 APPR: RAS 11/20/92					
∇ = 0	GENERAL TOLERANCES (UNLESS SPECIFIED)								
∇ = 0	MM	INCH							
∇ = 0	4 PLACES	±	±						
∇ = 0	3 PLACES	±	0.01 ±						
∇ = 0	2 PLACES	±	0.014 ± 0.25						
∇ = 0	1 PLACE	±	± 0.35						
∇ = 0	0 PLACES	±	±						
∇ = 0	ANGULAR TOL ± 0.5°			THIRD ANGLE PROJECTION					
∇ = 0	DRAFT WHERE APPLICABLE MUST REMAIN WITHIN DIMENSIONS			DRAWING		SERIES		MATERIAL NUMBER	
				C-SIZE		2589		SEE CHART	
				CUSTOMER		SHEET NUMBER		REVISION	
				GENERAL MARKET		1 OF 3		PSD 001 AD1	

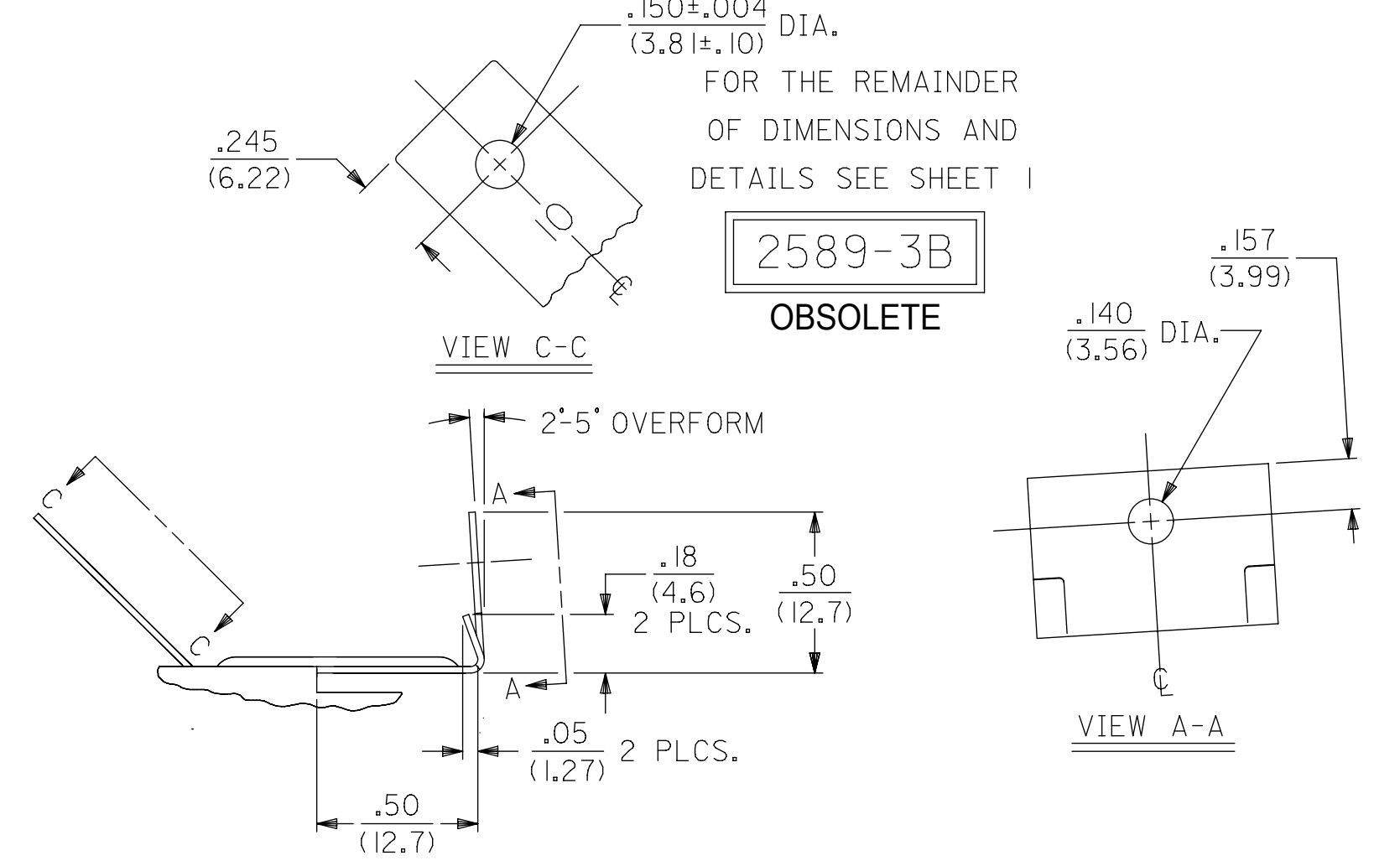
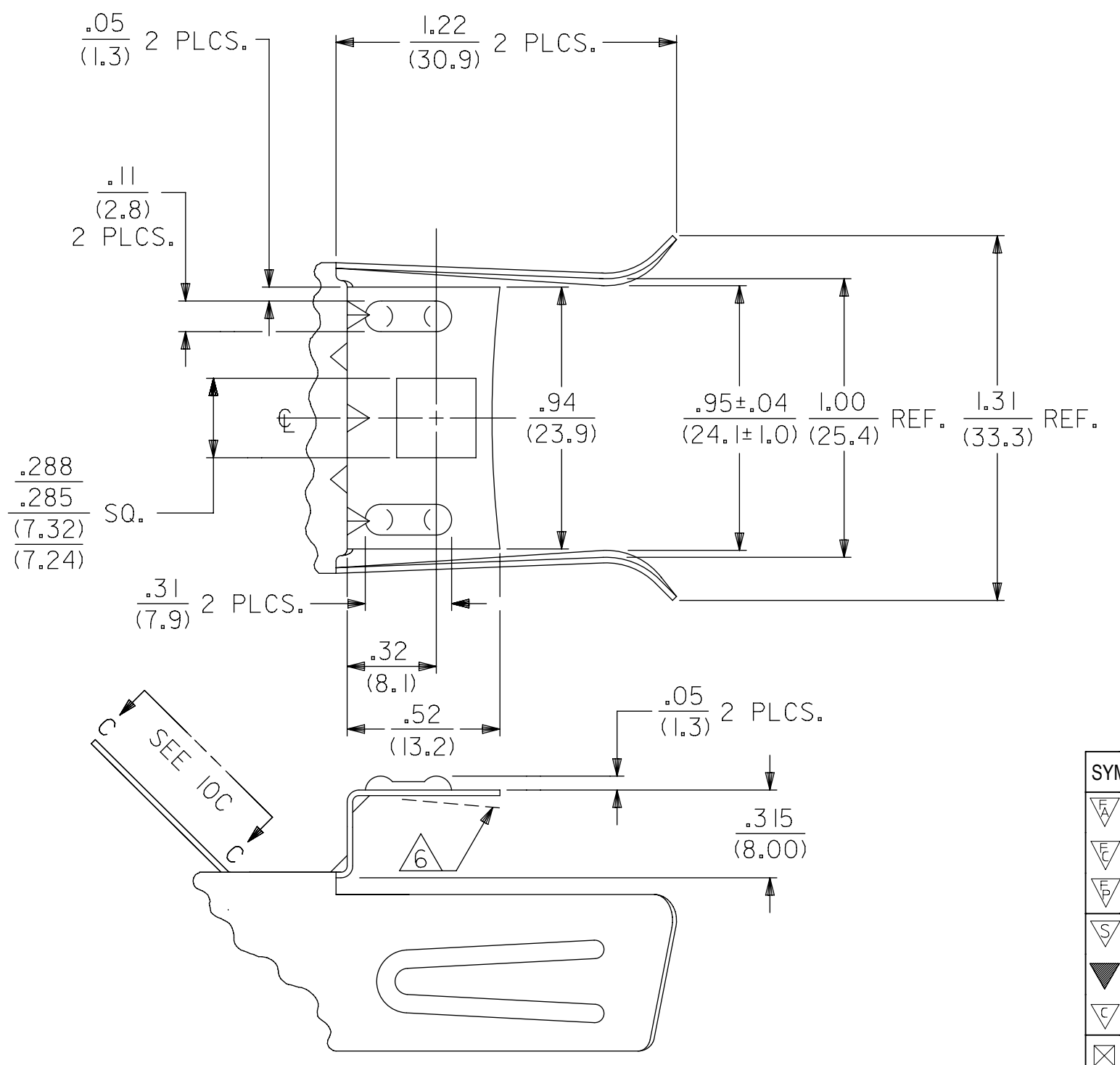
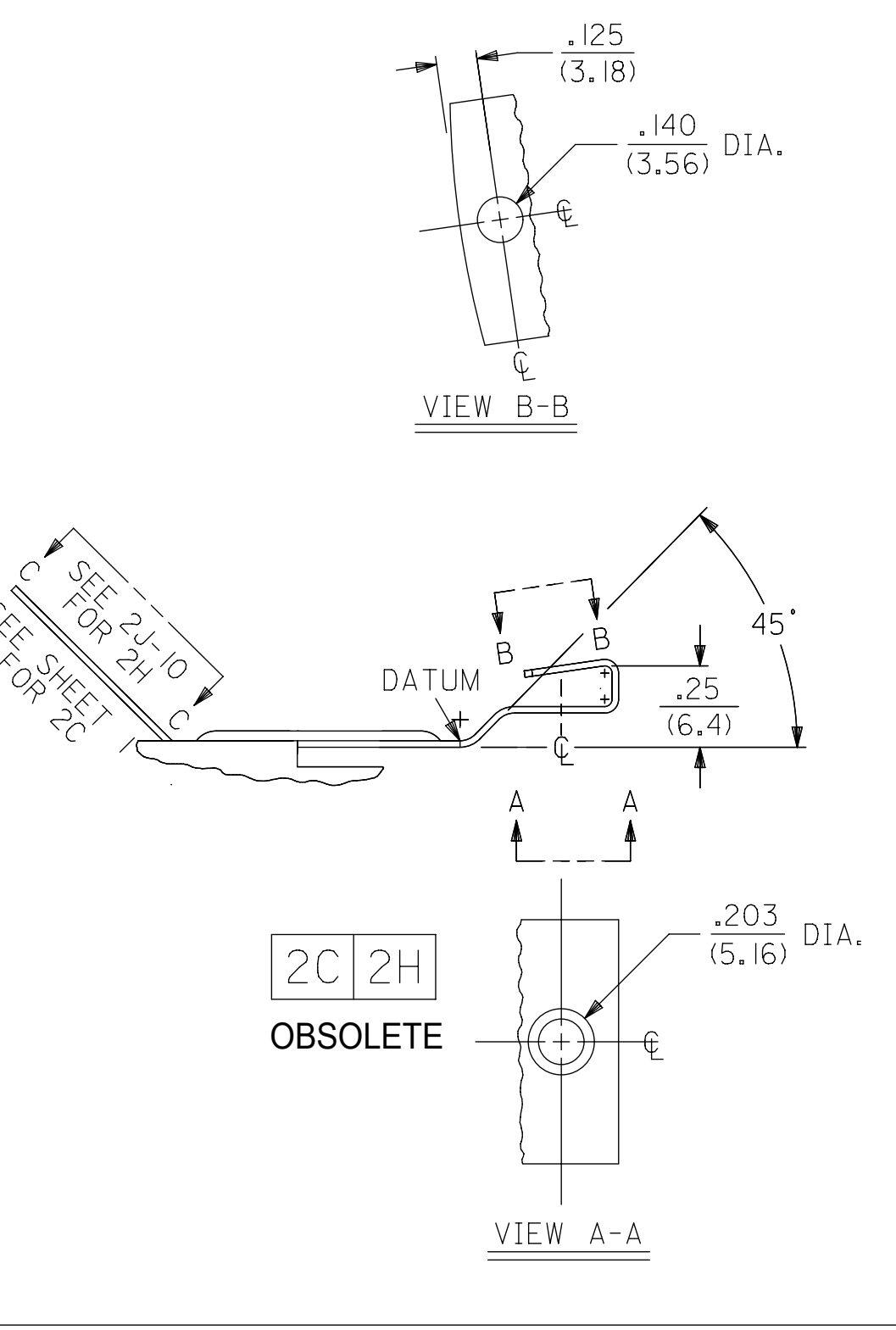
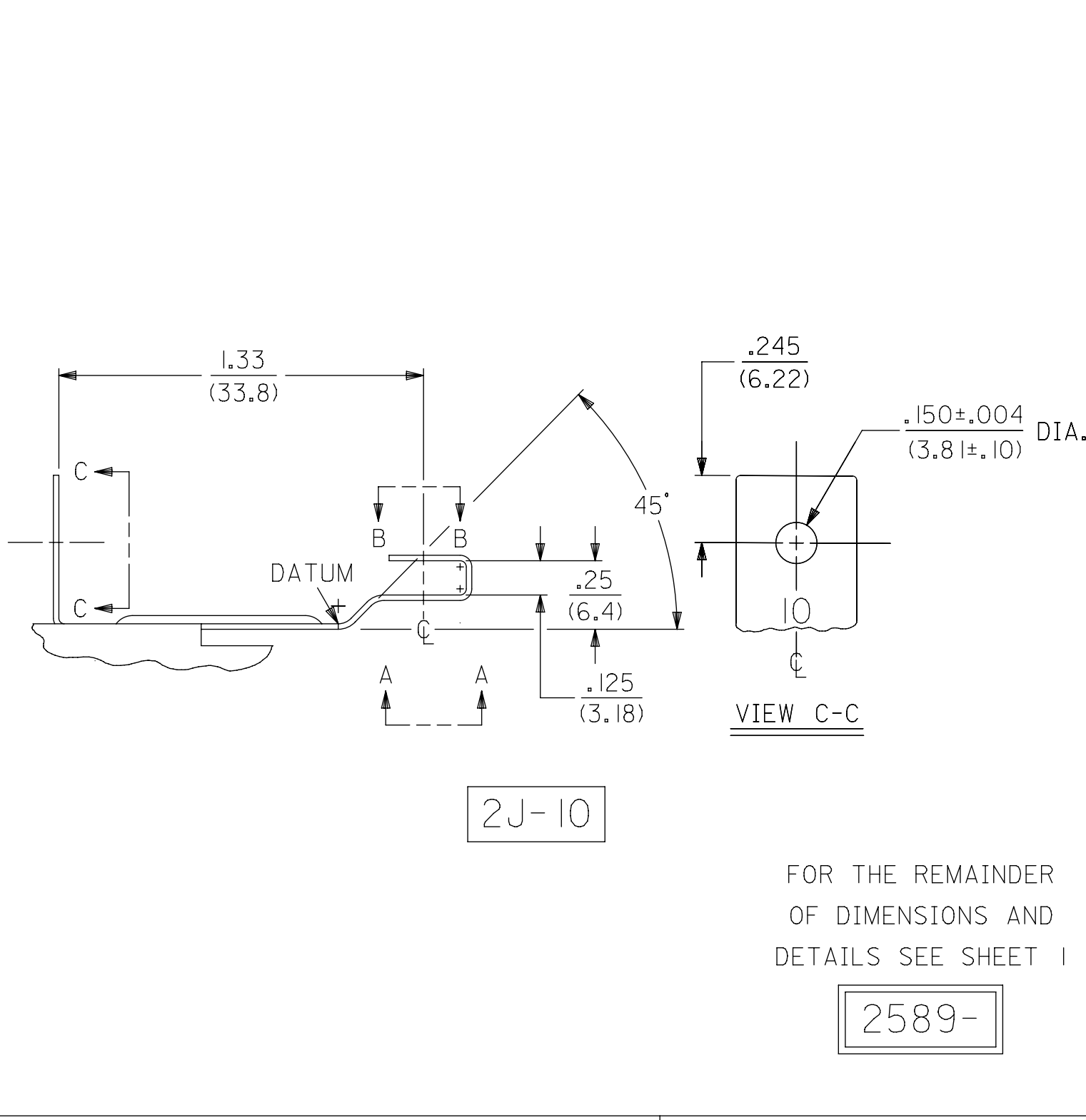
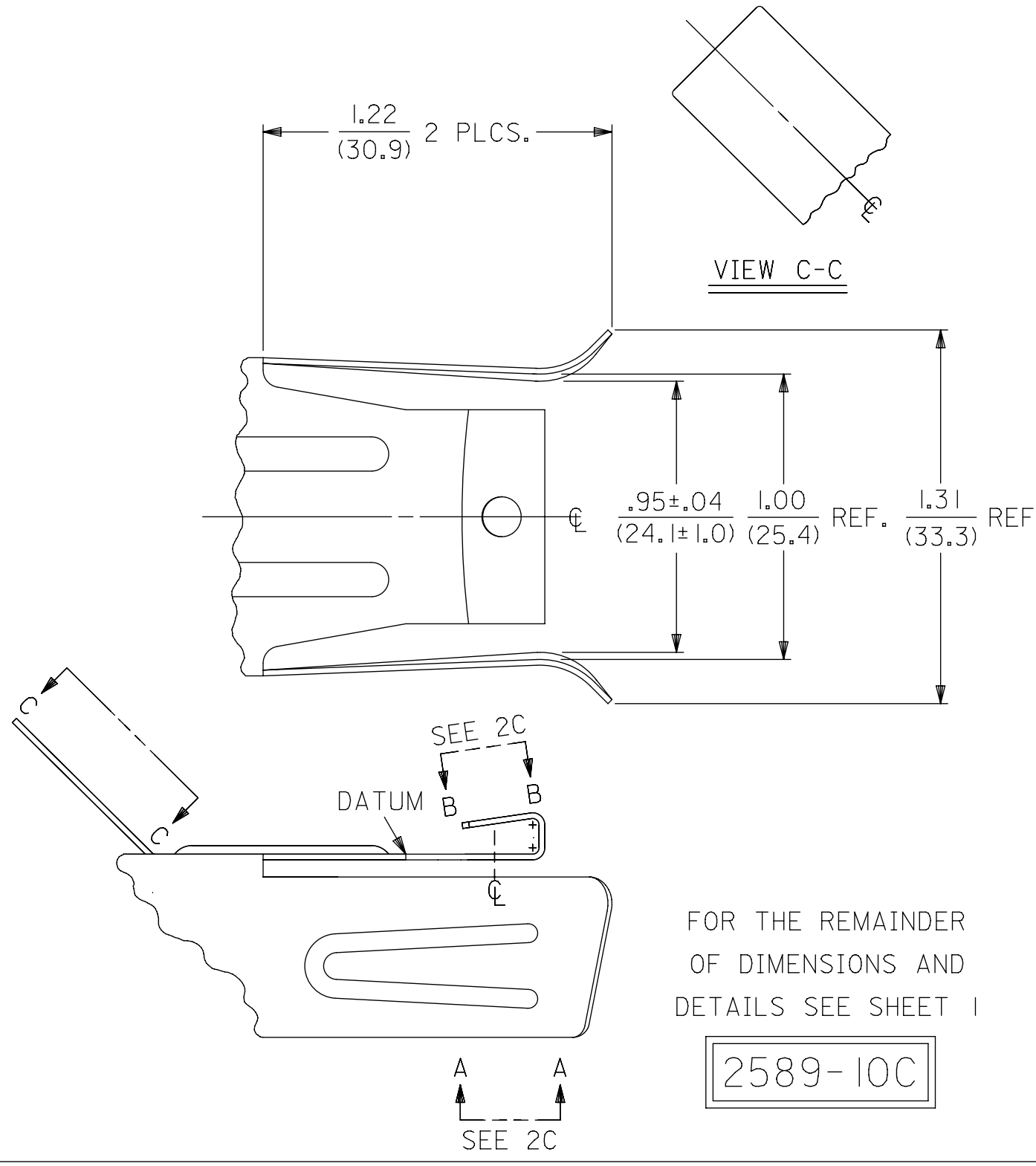

SYMBOLS		THIS DRAWING CONTAINS INFORMATION THAT IS PROPRIETARY TO MOLEX ELECTRONIC TECHNOLOGIES, LLC AND SHOULD NOT BE USED WITHOUT WRITTEN PERMISSION		CURRENT REV DESC: IMPORT TO NX	
∇ = 0	IN/MM	SCALE	2:1		
∇ = 0	GENERAL TOLERANCES (UNLESS SPECIFIED)		EC NO: 608062		
∇ = 0	MM	INCH	DRWN: SALHAMY	2018/11/21	MATERIAL NUMBER
∇ = 0	4 PLACES ±	±	CHK'D: MKIPPER	2018/11/21	
∇ = 0	3 PLACES ±	0.01	APPR: FSMITH	2018/11/21	SERIES
∇ = 0	2 PLACES ±	0.014	INITIAL REVISION:		
∇ = 0	1 PLACE ±	±	0 PLACES ±	±	THIRD ANGLE PROJECTION
∇ = 0	ANGULAR TOL ± 0.5°		DRWN: RHR	11/20/92	
∇ = 0	DRAFT WHERE APPLICABLE MUST REMAIN WITHIN DIMENSIONS		APPR: RAS	11/20/92	

<b>molex</b>			
MOUNTING CLIP			
PRODUCT CUSTOMER DRAWING			
DOCUMENT NUMBER	DOC TYPE	DOC PART	REVISION
SD-2589-X	PSD	001	AD1
MATERIAL NUMBER	CUSTOMER	SHEET NUMBER	
SEE CHART	GENERAL MARKET	2 OF 3	

PART NO.	ENG. NO.	DIMENSION	
		A	
089-00-2006	2589-ID-10	.48±.025 (12.2±.64)	
089-00-2027	2589-2J-10	.562±.025 (14.27±.64)	
089-00-2047	2589-6F	.375±.015 (9.53±.38)	
089-00-2100	2589-10C	.48±.025 (12.2±.64)	
089-00-2103	2589-23	.62±.025 (15.7±.64)	

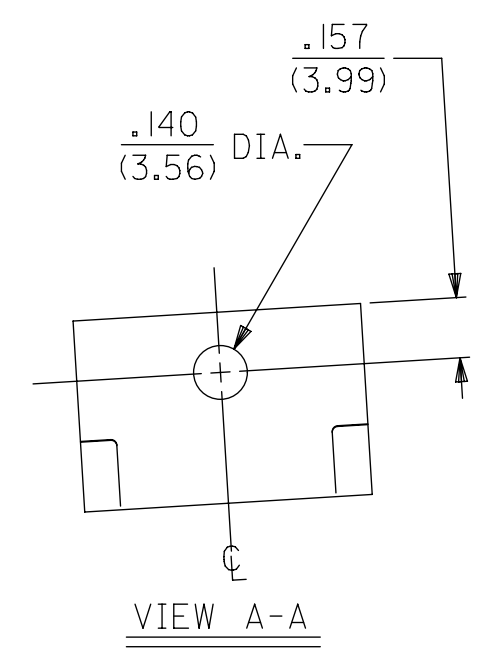
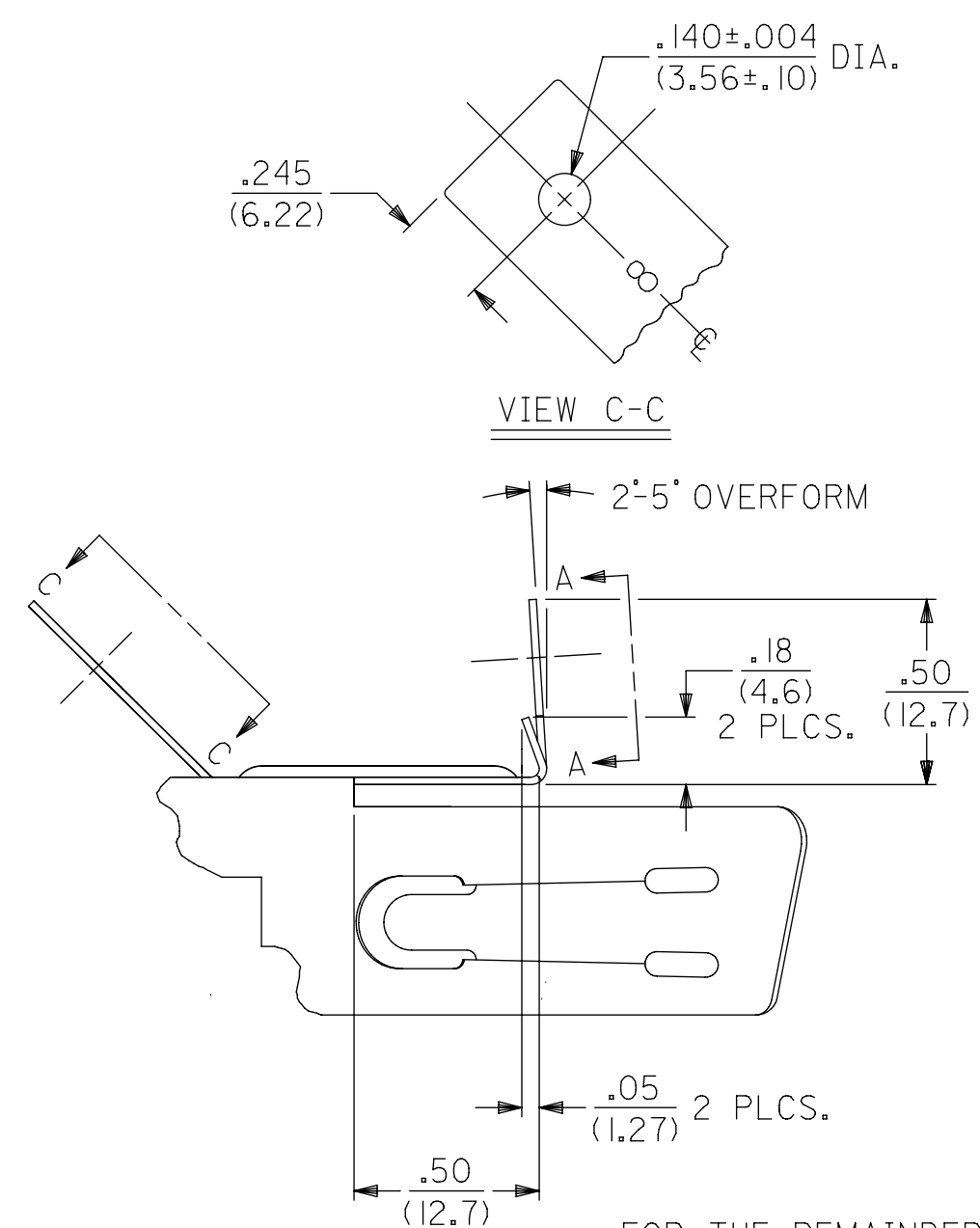
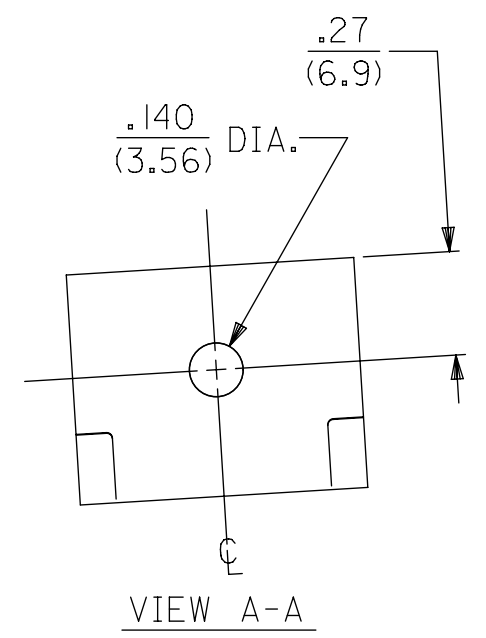
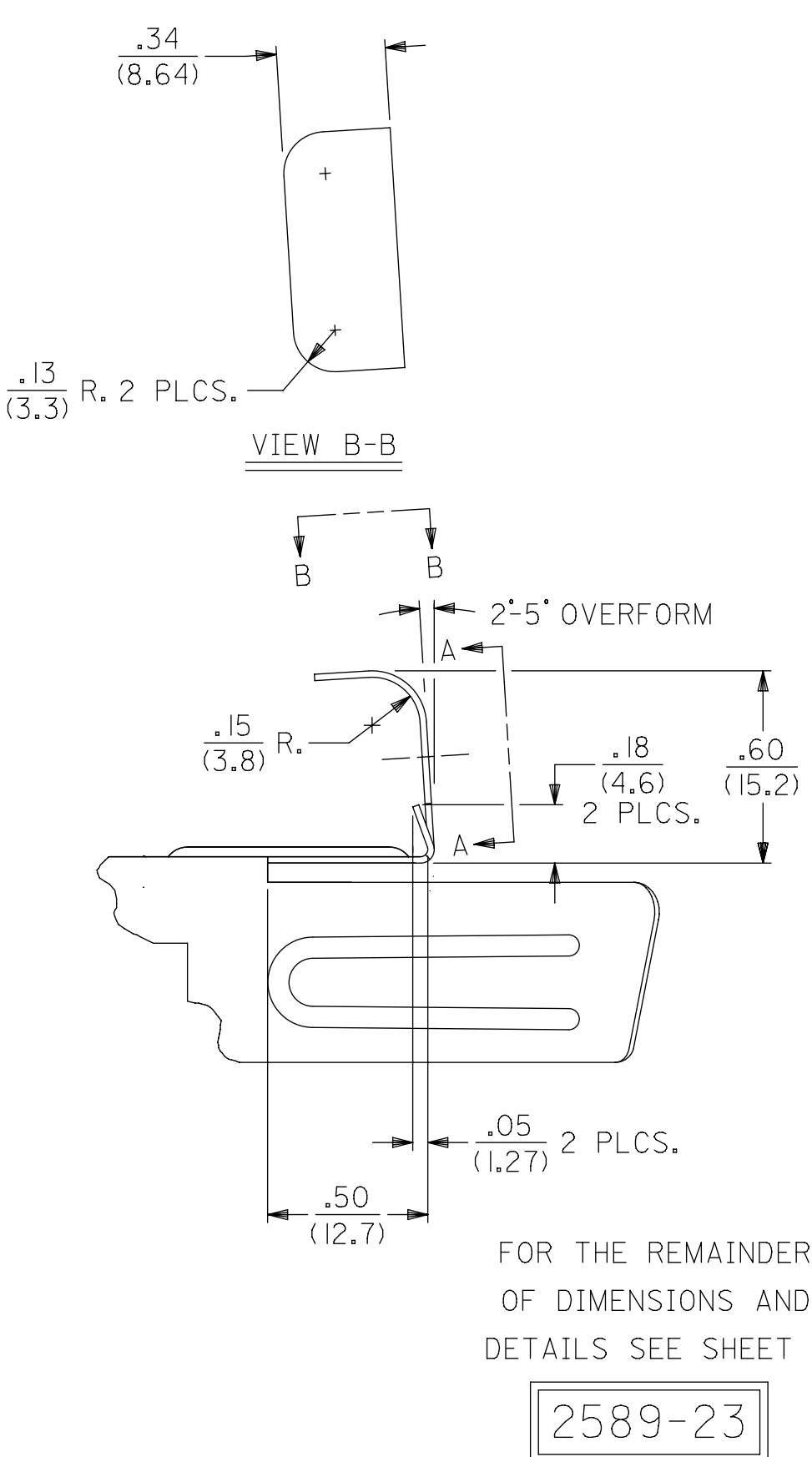

FOR THE REMAINDER  
OF DIMENSIONS AND  
DETAILS SEE SHEET 1

2589-21A

OBSOLETE

SYMBOLS	THIS DRAWING CONTAINS INFORMATION THAT IS PROPRIETARY TO MOLEX ELECTRONIC TECHNOLOGIES, LLC AND SHOULD NOT BE USED WITHOUT WRITTEN PERMISSION			
	DIMENSION UNITS	SCALE		CURRENT REV DESC: IMPORT TO NX
▽ = 0	IN/MM	1:1		<b>molex</b>  MOUNTING CLIP  PRODUCT CUSTOMER DRAWING
▽ = 0	GENERAL TOLERANCES (UNLESS SPECIFIED)			
▽ = 0		MM	INCH	
▽ = 0	4 PLACES	±	±	
▽ = 0	3 PLACES	± 0.01	±	EC NO: 608062 DRWN: SALHAMY 2018/11/21 CHK'D: MKIPPER 2018/11/21 APPR: FSMITH 2018/11/21
▽ = 0	2 PLACES	± 0.014	± 0.25	INITIAL REVISION: DRWN: RHR 11/20/92 APPR: RAS 11/20/92
▽ = 0	1 PLACE	±	± 0.35	
▽ = 0	0 PLACES	±	±	DOCUMENT NUMBER: SD-2589-X DOC TYPE: PSD DOC PART: 001 REVISION: AD1
▽ = 0	ANGULAR TOL	± 0.5 °		MATERIAL NUMBER: SEE CHART CUSTOMER: GENERAL MARKET SHEET NUMBER: 3 OF 3
▽ = 0	DRAFT WHERE APPLICABLE MUST REMAIN WITHIN DIMENSIONS	THIRD ANGLE PROJECTION	DRAWING: C-SIZE	SERIES: 2589