

Single Wire CAN Transceiver

The 33897 Series provides a physical layer for digital communications purposes using a Carrier Sense Multiple Access/Collision Resolution (CSMA/CR) data link operating over a single wire medium. This is more commonly referred to as Single Wire Controller Area Network (CAN).

The 33897 Series operates directly from a vehicle's 12 V battery system or a broad range of DC-power sources. It can operate at either low or high (33.33 kbps or 83.33 kbps) data rates. A high-voltage wake-up feature allows the device to control the regulator used in support of the MCU and other logic. The device includes a control terminal that can be used to put the module regulator into Sleep mode. The presence of a defined wake-up voltage level on the bus will reactivate the control line to turn the regulator and the system back on.

The device complies with the GMW3089v2.4 General Motors Corporation specification.

Features

- Waveshaping for Low Electromagnetic Interference (EMI)
- Detects and Automatically Handles Loss of Ground
- Worst-Case Sleep Mode Current of Only 60 μ A (75 μ A on the 33897T)
- Current Limit Prevents Damage Due to Bus Shorts
- Built-In Thermal Shutdown on Bus Output
- Protected Against Vehicular Electrical Transients
- Undervoltage Lockout Prevents False Data with Low Battery
- Pb-Free Packaging Designated by Suffix Code EF

33897/A/B/C/D/T

SINGLE WIRE CAN
TRANSCEIVER

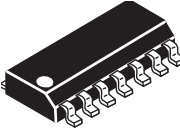

D SUFFIX
EF (PB-FREE) SUFFIX
98ASB42565B
14-TERMINAL SOICN

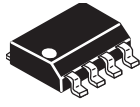

EF (PB-FREE) SUFFIX
98ASB42564B
8-TERMINAL SOICN

ORDERING INFORMATION				
Contains Lead	Pb-Free	RoHS	Temperature Range (T _A)	Package
MC33897D/R2	MC33897EF/R2	MCZ33897EF/R2	-40°C to 125°C	14 SOICN
MC33897AD/R2	MC33897AEF/R2	MCZ33897TEF/R2 MCZ33897AEF/R2 *MCZ33897CEF/R2		
	MC33897BEF/R2	MCZ33897BEF/R2 *MCZ33897DEF/R2		8 SOICN

*Recommended device for all new designs

* This document contains certain information on a new product. Specifications and information herein are subject to change without notice.

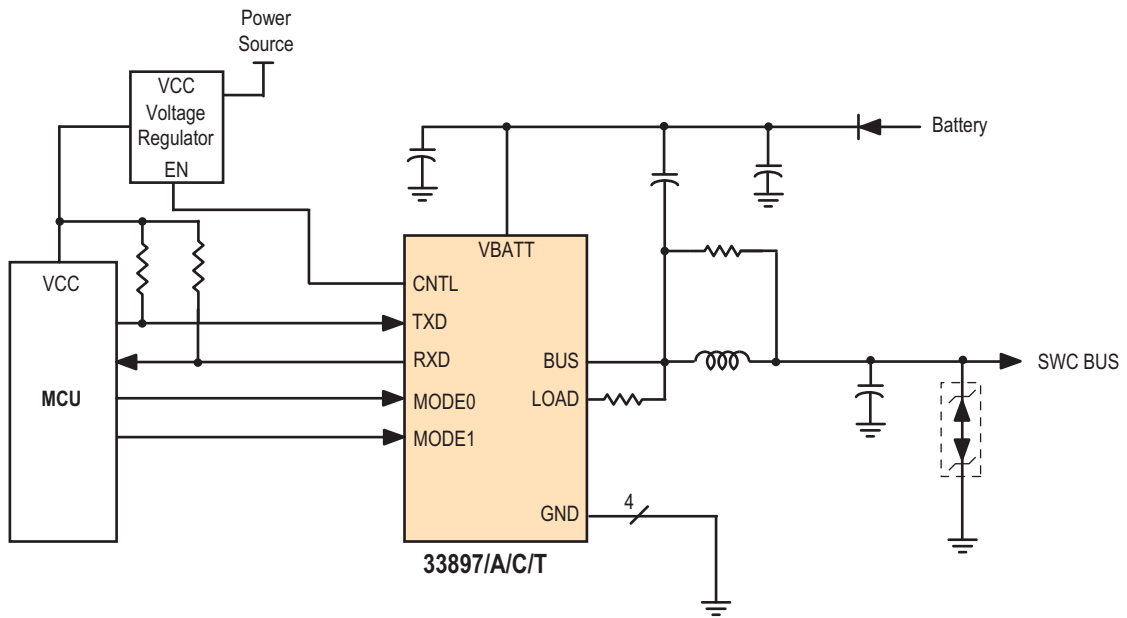

Figure 1. 33897/A/C Simplified Application Diagram

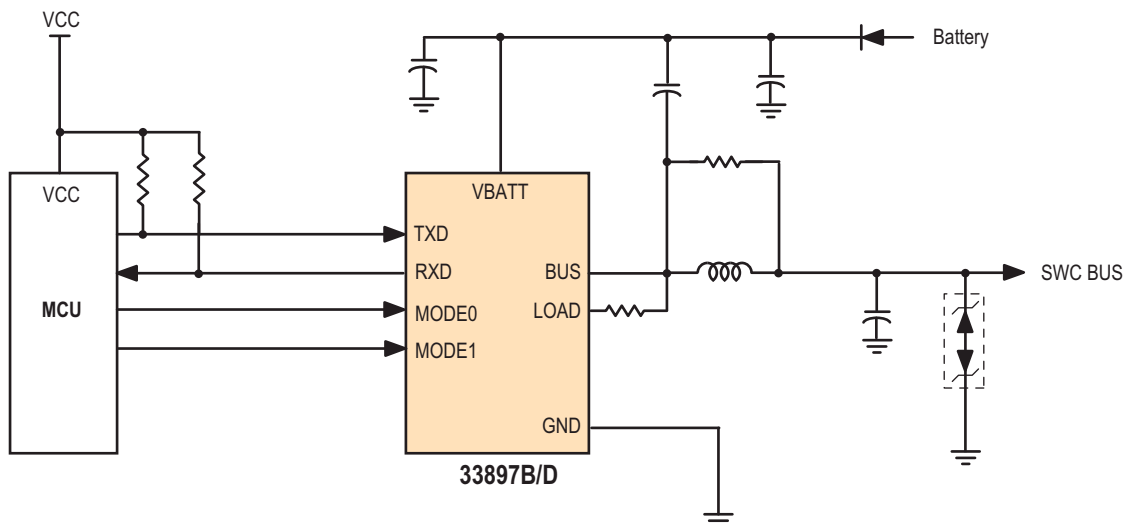

Figure 2. 33897B/D Simplified Application Diagram

DEVICE VARIATIONS

Table 1. Device Variations

Part No.	Load Voltage Sleep Mode	Other Significant Differences	See Page
33897	1.0 V Max	<ul style="list-style-type: none"> • 14-Pin Package 	8
33897T		<ul style="list-style-type: none"> • 14-Pin Package • Quiescent Current in Sleep Mode, $5.0V \leq V_{BATT} \leq 13V$, Typical - 55 μA, Max - 75μA • ESD Voltage: Machine Model $\pm 100V$ 	6 , 7 , 8
33897A	0.1 V Max	<ul style="list-style-type: none"> • 14-Pin Package • Removes diode drop during Sleep Mode • May not detect Loss of Ground under certain module characteristics. 	8
33897B		<ul style="list-style-type: none"> • 8-Pin Package • Removes diode drop during Sleep Mode • Does not include the CNTL terminal • May not detect Loss of Ground under certain module characteristics. 	2 , 4 , 6 , 7 , 8 , 13 , 16
*33897C		<ul style="list-style-type: none"> • 14-Pin Package • Removes diode drop during Sleep Mode • Effectively detects Loss of Ground • ESD Voltage: Human Body Model $\pm 1500V$, Machine Model $\pm 100V$ 	8
*33897D		<ul style="list-style-type: none"> • 8-Pin Package • Removes diode drop during Sleep Mode • Effectively detects Loss of Ground • Does not include the CNTL terminal • ESD Voltage: Human Body Model $\pm 1500V$, Machine Model $\pm 100V$ 	2 , 4 , 6 , 7 , 8 , 13 , 16

*Recommended device for all new designs

INTERNAL BLOCK DIAGRAM

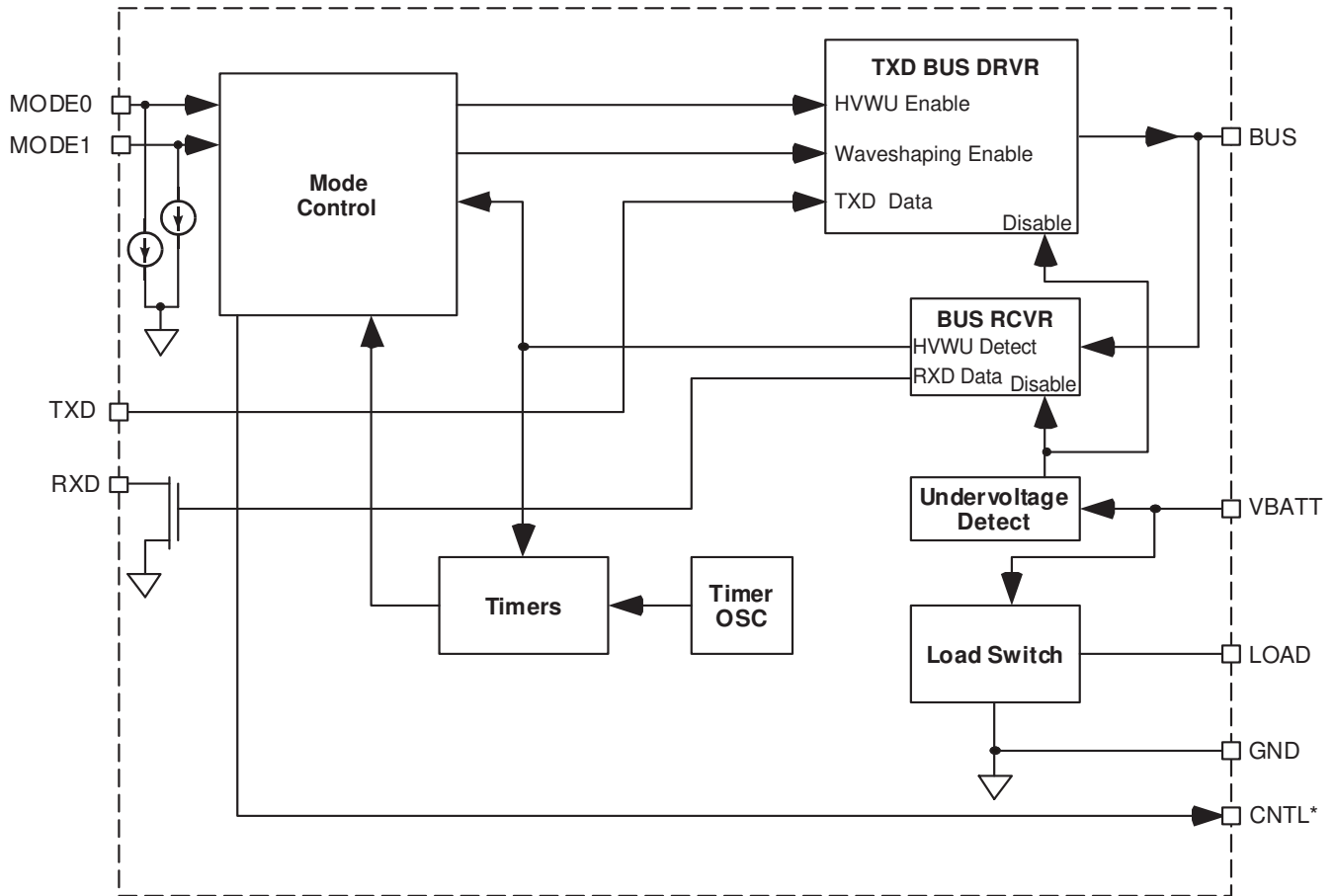

*CNTL terminal is present on 33897/A/C/T only.

Figure 3. 33897/A/B/C/D/T Simplified Internal Block Diagram

PIN CONNECTIONS

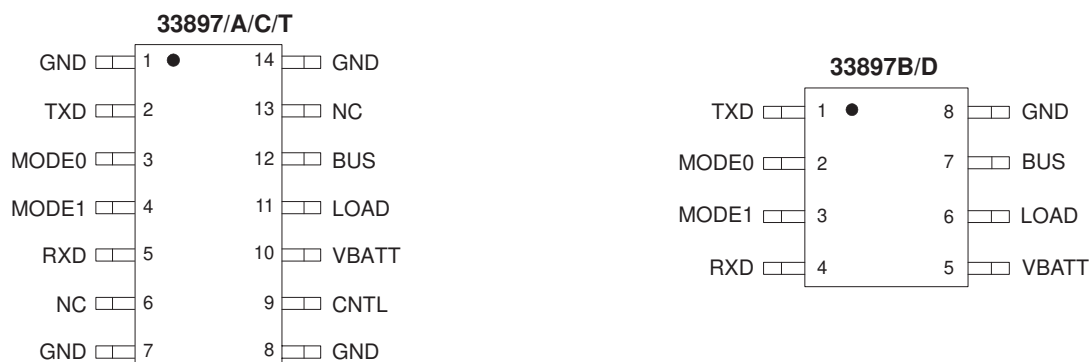

Figure 4. 33897/A/B/C/D/T Pin Connections

Table 2. Pin Definitions

A functional description of each terminal can be found in the Functional Pin Description section, beginning on page [13](#).

33897/A/C/T Terminal	33897B/D Terminal	Pin Name	Formal Name	Definition
1, 7, 8, 14	8	GND	Ground	Electrical Common Ground and Heat removal. A good thermal path will also reduce the die temperature.
2	1	TXD	Transmit Data	Data input here will appear on the BUS terminal. A logic [0] will assert the bus, a logic [1] will make the bus go to the recessive state.
3, 4	2, 3	MODE0, MODE1	Mode Control	These Pins control Sleep Mode, Transmit Level, and Speed. They have weak pulldowns.
5	4	RXD	Receive Data	Open drain output of the data on BUS. A recessive bus = a logic [1], a dominant bus = logic [0]. An external pullup is required.
6, 13	–	NC	No Connect	No internal connection to these Pins. Pin 13 can be connected to GND to allow the use of the 14-terminal or 8-terminal device. ⁽¹⁾
9	–	CNTL	Control	Provides a battery-level logic signal.
10	5	VBATT	Battery	Power input. An external diode is needed for reverse battery protection.
11	6	LOAD	Load	The external bus load resistor connects here to prevent bus pullup in the event of loss of module ground.
12	7	BUS	Bus	This terminal connects to the bus through external components.

Notes

1. Module boards can be planned for the 14-terminal package and still use the 8-terminal package.

ELECTRICAL CHARACTERISTICS

MAXIMUM RATINGS

Table 3. Maximum Ratings

All voltages are with respect to ground unless otherwise noted.

Rating	Symbol	Value	Unit
Electrical Ratings			
Supply Voltage	V_{BATT}	-0.3 to 40	V
Input Logic Voltage	V_{IN}	-0.3 to 7.0	V
RXD Pin Voltage	V_{RXD}	-0.3 to 7.0	V
CNTL Pin Voltage (33897/A/C/T only)	V_{CNTL}	-0.3 to 40	V
ESD Voltage ⁽²⁾	V_{ESD}		V
Human Body Model			
All Pins Except BUS	33897/A/B/T 33897C/D	±2000 ±1500	
BUS Terminal (All Pkgs)		±4000	
Machine Model	33897/A/B 33897C/D/T	±200 ±100	
Thermal Ratings			
Ambient Operating Temperature ⁽³⁾	T_A	-40 to 125	°C
Junction Operating Temperature	T_J	-40 to 150	°C
Storage Temperature	T_{STG}	-55 to 150	°C
Junction-to-Ambient Thermal Resistance	$R_{\theta JA}$	150	°C/W
Peak Package Reflow Temperature During Reflow ^{(4), (5)}	T_{PPRT}	Note 5.	°C

Notes

- ESD testing is performed in accordance with the Human Body Model ($C_{ZAP} = 100 \text{ pF}$, $R_{ZAP} = 1500 \text{ } \Omega$), Machine Model ($C_{ZAP} = 200 \text{ pF}$, $R_{ZAP} = 0 \text{ } \Omega$).
- When using the 8-terminal device, consider the power dissipation at a high operating voltage and maximum network loading at ambient temperatures exceeding 85°C.
- Pin soldering temperature limit is for 10 seconds maximum duration. Not designed for immersion soldering. Exceeding these limits may cause malfunction or permanent damage to the device.
- Freescale's Package Reflow capability meets Pb-free requirements for JEDEC standard J-STD-020C. For Peak Package Reflow Temperature and Moisture Sensitivity Levels (MSL), Go to www.freescale.com, search by part number [e.g. remove prefixes/suffixes and enter the core ID to view all orderable parts. (i.e. MC33xxxD enter 33xxx), and review parametrics.

STATIC ELECTRICAL CHARACTERISTICS

Table 4. Static Electrical Characteristics

Characteristics noted under conditions of $-40^{\circ}\text{C} \leq T_A \leq 125^{\circ}\text{C}$, unless otherwise stated. Voltages are relative to GND unless otherwise noted. All positive currents are into the terminal. All negative currents are out of the terminal.

Characteristic	Symbol	Min	Typ	Max	Unit
GENERAL					
Quiescent Current Sleep $5.0\text{ V} \leq V_{\text{BATT}} \leq 13\text{ V}$ ⁽⁶⁾ 33897/A/B/C/D 33897T	I_{QSLP}	–	45 55	60 75	μA
Awake with Transmitter Disabled $5.0\text{ V} \leq V_{\text{BATT}} \leq 26.5\text{ V}$	I_{QATDIS}	–	–	4.0	mA
Awake with Transmitter Enabled $5.0\text{ V} \leq V_{\text{BATT}} \leq 26.5\text{ V}$	I_{QATEN}	–	–	9.0	mA
Undervoltage Shutdown	V_{BATTUV}	4.0	–	5.0	V
Undervoltage Hysteresis	V_{UVHYS}	0.1	–	0.5	V
Thermal Shutdown ⁽⁷⁾ $5.0\text{ V} \leq V_{\text{BATT}} \leq 26.5\text{ V}$	T_{SD}	150	–	190	$^{\circ}\text{C}$
Thermal Shutdown Hysteresis ⁽⁷⁾ $5.0\text{ V} \leq V_{\text{BATT}} \leq 26.5\text{ V}$	T_{SDHYS}	10	–	20	$^{\circ}\text{C}$

LOGIC I/O, MODE0, MODE1, TXD, RXD

Logic Input Low Level (MODE0, MODE1, and TXD) $5.0\text{ V} \leq V_{\text{BATT}} \leq 26.5\text{ V}$	V_{IL}	–	–	0.8	V
Logic Input High Level (MODE0, MODE1, and TXD) $5.0\text{ V} \leq V_{\text{BATT}} \leq 26.5\text{ V}$	V_{IH}	2.0	–	–	V
Mode Pin Pulldown Current (MODE0 and MODE1) Pin Voltage = 0.8 V, $5.0\text{ V} \leq V_{\text{BATT}} \leq 26.5\text{ V}$	I_{PD}	10	–	50	μA
Receiver Output Low (RXD) $I_{\text{IN}} = 2.0\text{ mA}$, $5.0\text{ V} \leq V_{\text{BATT}} \leq 26.5\text{ V}$	V_{OL}	–	–	0.45	V

CNTL (33897/A/C/T ONLY)

CNTL Output Low $I_{\text{IN}} = 5.0\ \mu\text{A}$, $5.0\text{ V} \leq V_{\text{BATT}} \leq 26.5\text{ V}$	V_{OLCNTL}	–	–	0.8	V
CNTL Output High $I_{\text{OUT}} = 180\ \mu\text{A}$, $5.0\text{ V} \leq V_{\text{BATT}} \leq 26.5\text{ V}$	V_{OHCNTL}	$V_{\text{BATT}} - 0.8$	–	V_{BATT}	V

Notes

6. After t_{CNTLFDLY}
7. Thermal shutdown causes the BUS output driver to be disabled. Guaranteed by characterization.

Table 4. Static Electrical Characteristics (continued)

Characteristics noted under conditions of $-40^{\circ}\text{C} \leq T_A \leq 125^{\circ}\text{C}$, unless otherwise stated. Voltages are relative to GND unless otherwise noted. All positive currents are into the terminal. All negative currents are out of the terminal.

Characteristic	Symbol	Min	Typ	Max	Unit
LOAD					
LOAD Voltage Rise ⁽⁸⁾ Normal Speed and Voltage Mode, Transmit High-Voltage Mode, Transmit High-Speed Mode $I_{IN} = 1.0 \text{ mA}$, $5.0 \text{ V} \leq V_{BATT} \leq 26.5 \text{ V}$ Sleep Mode $I_{IN} = 7.0 \text{ mA}$ 33897/T $I_{IN} = 7.0 \text{ mA}$ ⁽⁹⁾ 33897A/B/C/D Loss of Battery $I_{IN} = 7.0 \text{ mA}$	V_{LDRISE}	–	–	0.1	V
LOAD Leakage During Loss of Module Ground ⁽¹⁰⁾ $0.0 \text{ V} \leq V_{BATT} \leq 18 \text{ V}$ 33897A/B/T $0.0 \text{ V} \leq V_{BATT} \leq 18 \text{ V}$ 33897C/D	I_{LDLEAK}	0.0 -10	– –	-90 10	μA
BUS					
Passive Out BUS Leakage Passive In $0.0 \text{ V} \leq V_{BATT} \leq 26.5 \text{ V}$, $-1.5 \text{ V} \leq V_{BUS} < 0 \text{ V}$ Active In $0.0 \text{ V} \leq V_{BATT} \leq 26.5 \text{ V}$, $0 \text{ V} < V_{BUS} \leq 12.5 \text{ V}$ BUS Leakage During Loss of Module Ground ⁽¹¹⁾ $0.0 \text{ V} \leq V_{BATT} \leq 18 \text{ V}$ 33897A/B/T $0.0 \text{ V} \leq V_{BATT} \leq 18 \text{ V}$ 33897C/D	I_{LEAK} $I_{LKA I}$ I_{BLKLOG}	-5.0 -5.0 -10 0.0	– – – –	5.0 5.0 10 -90	μA
High-Voltage Wake-up Mode Output High Voltage $12 \text{ V} \leq V_{BATT} \leq 26.5 \text{ V}$, $200 \Omega \leq R_L \leq 3332 \Omega$ 33897/T $5.0 \text{ V} \leq V_{BATT} < 12 \text{ V}$, $200 \Omega \leq R_L \leq 3332 \Omega$ 33897A/B/C/D	$V_{HVVUOHF}$ $V_{HVVUOHO}$	9.7 9.9 Lesser of $V_{BAT} - 1.5$ or 9.7	– –	12.5 12.5 V_{BATT}	V
High-Speed Mode Output High Voltage $8.0 \text{ V} \leq V_{BATT} \leq 16 \text{ V}$, $75 \Omega \leq R_L \leq 135 \Omega$	V_{OHHS}	4.2	–	5.1	V
Normal Mode Output High Voltage $6.0 \text{ V} \leq V_{BATT} \leq 26.5 \text{ V}$, $200 \Omega \leq R_L \leq 3332 \Omega$ $5.0 \text{ V} \leq V_{BATT} < 6.0 \text{ V}$, $200 \Omega \leq R_L \leq 3332 \Omega$	V_{NOHF} V_{NOHO}	4.4 Lesser of $V_{BATT} - 1.6$ or 4.4	– –	5.1 Lesser of V_{BATT} or 5.1	V
BUS Low Voltage $5.0 \text{ V} \leq V_{BATT} \leq 26.5 \text{ V}$, $200 \Omega \leq R_L \leq 3332 \Omega$	V_{OL}	-0.2	–	0.2	V
Short Circuit BUS Output Current Dominant State, $5.0 \text{ V} \leq V_{BATT} \leq 26.5 \text{ V}$	I_{BSC}	-350	–	-150	mA

Notes

- GMW3089V2.4 specifies the maximum load voltage rise to be 0.1 V whenever module battery is intact, including when in Sleep mode. The maximum load voltage rise of 1.0 V in Sleep mode is a GM-approved exception to GMW3089V2.4.
- 33897A/B/C/D remove diode drop during Sleep mode.
- LOAD terminal is at system ground voltage.
- BUS terminal is at system ground voltage

Table 4. Static Electrical Characteristics (continued)

Characteristics noted under conditions of $-40^{\circ}\text{C} \leq T_A \leq 125^{\circ}\text{C}$, unless otherwise stated. Voltages are relative to GND unless otherwise noted. All positive currents are into the terminal. All negative currents are out of the terminal.

Characteristic	Symbol	Min	Typ	Max	Unit
BUS (CONTINUED)					
Input Threshold					V
Awake 5.0 V \leq V _{BATT} \leq 26.5 V	V _{BIA}	2.0	–	2.2	
Sleep 12 V \leq V _{BATT} \leq 26.5 V	V _{BISF}	6.6	–	7.9	
Sleep 5.0 V \leq V _{BATT} < 12 V	V _{BISO}	Lesser of 6.6 V or V _{BATT} - 4.3	–	Lesser of 7.9 V or V _{BATT} - 3.25	

DYNAMIC ELECTRICAL CHARACTERISTICS

Table 5. Dynamic Electrical Characteristics

Characteristics noted under conditions of $-40^{\circ}\text{C} \leq T_A \leq 125^{\circ}\text{C}$, unless otherwise stated. Voltages are relative to GND unless otherwise noted. All positive currents are into the terminal. All negative currents are out of the terminal.

Characteristic	Symbol	Min	Typ	Max	Unit
BUS					
Normal Speed Rising Output Delay $200\ \Omega \leq R_L \leq 3332\ \Omega$, $1.0\ \mu\text{s} \leq \text{Load Time Constants} \leq 4.0\ \mu\text{s}$ Measured from TXD = V_{IL} to V_{BUS} as follows: Max Time to $V_{BUSMOD} = 3.7\ \text{V}$, $6.0\ \text{V} \leq V_{BATT} \leq 26.5\ \text{V}$ ⁽¹²⁾ Min Time to $V_{BUSMOD} = 1.0\ \text{V}$, $6.0\ \text{V} \leq V_{BATT} \leq 26.5\ \text{V}$ ⁽¹²⁾ Max Time to $V_{BUSMOD} = 2.7\ \text{V}$, $V_{BATT} = 5.0\ \text{V}$ ⁽¹²⁾ Min Time to $V_{BUSMOD} = 1.0\ \text{V}$, $V_{BATT} = 5.0\ \text{V}$ ⁽¹²⁾	$t_{DLYNORMRO}$	2.0	–	6.3	μs
Normal Speed Falling Output Delay $200\ \Omega \leq R_L \leq 3332\ \Omega$, $1.0\ \mu\text{s} \leq \text{Load Time Constants} \leq 4.0\ \mu\text{s}$ Measured from TXD = V_{IH} to V_{BUS} as follows: Max Time to $V_{BUSMOD} = 1.0\ \text{V}$, $6.0\ \text{V} \leq V_{BATT} \leq 26.5\ \text{V}$ ⁽¹²⁾ Min Time to $V_{BUSMOD} = 3.7\ \text{V}$, $6.0\ \text{V} \leq V_{BATT} \leq 26.5\ \text{V}$ ⁽¹²⁾ Max Time to $V_{BUSMOD} = 1.0\ \text{V}$, $V_{BATT} = 5.0\ \text{V}$ ⁽¹²⁾ Min Time to $V_{BUSMOD} = 2.7\ \text{V}$, $V_{BATT} = 5.0\ \text{V}$ ⁽¹²⁾	$t_{DLYNORMFO}$	1.8	–	8.5	μs
High-Speed Rising Output Delay $75\ \Omega \leq R_L \leq 135\ \Omega$, $0.0\ \mu\text{s} \leq \text{Load Time Constants} \leq 1.5\ \mu\text{s}$, $8.0\ \text{V} \leq V_{BATT} \leq 16\ \text{V}$ Measured from TXD = V_{IL} to V_{BUS} as follows: Max Time to $V_{BUS} = 3.7\ \text{V}$ ⁽¹³⁾ Min Time to $V_{BUS} = 1.0\ \text{V}$ ⁽¹³⁾	$t_{DLYHSRO}$	0.1	–	1.7	μs
High-Speed Falling Output Delay $75\ \Omega \leq R_L \leq 135\ \Omega$, $0.0\ \mu\text{s} \leq \text{Load Time Constants} \leq 1.5\ \mu\text{s}$, $8.0\ \text{V} \leq V_{BATT} \leq 16\ \text{V}$ Measured from TXD = V_{IH} to V_{BUS} as follows: Max Time to $V_{BUS} = 1.0\ \text{V}$ ⁽¹³⁾ Min Time to $V_{BUS} = 3.7\ \text{V}$ ⁽¹³⁾	$t_{DLYHSFO}$	0.04	–	3.0	μs

Notes

12. V_{BUSMOD} is the voltage at the BUSMOD node in [Figure 7](#), page 15.
13. V_{BUS} is the voltage at the BUS terminal in [Figure 8](#), page 15.

Table 5. Dynamic Electrical Characteristics (continued)

Characteristics noted under conditions of $-40^{\circ}\text{C} \leq T_A \leq 125^{\circ}\text{C}$, unless otherwise stated. Voltages are relative to GND unless otherwise noted. All positive currents are into the terminal. All negative currents are out of the terminal.

Characteristic	Symbol	Min	Typ	Max	Unit
BUS (CONTINUED)					
High-Voltage Rising Output Delay $200\ \Omega \leq R_L \leq 3332\ \Omega$, $1.0\ \mu\text{s} \leq \text{Load Time Constants} \leq 4.0\ \mu\text{s}$ Measured from $\text{TXD}=\text{V}_{\text{IL}}$ to V_{BUS} as follows: Max Time to $\text{V}_{\text{BUSMOD}} = 3.7\ \text{V}$, $6.0\ \text{V} \leq \text{V}_{\text{BATT}} \leq 26.5\ \text{V}$ ⁽¹⁴⁾ Min Time to $\text{V}_{\text{BUSMOD}} = 1.0\ \text{V}$, $6.0\ \text{V} \leq \text{V}_{\text{BATT}} \leq 26.5\ \text{V}$ ⁽¹⁴⁾ Max Time to $\text{V}_{\text{BUSMOD}} = 9.4\ \text{V}$, $12.0\ \text{V} \leq \text{V}_{\text{BATT}} \leq 26.5\ \text{V}$ ⁽¹⁴⁾	t_{DLYHVRO}	2.0 2.0 2.0	– – –	6.3 6.3 18	μs
High-Voltage Falling Output Delay $200\ \Omega \leq R_L \leq 3332\ \Omega$, $1.0\ \mu\text{s} \leq \text{Load Time Constants} \leq 4.0\ \mu\text{s}$, $12.0\ \text{V} \leq \text{V}_{\text{BATT}} \leq 26.5\ \text{V}$ Measured from $\text{TXD}=\text{V}_{\text{IH}}$ to V_{BUS} as follows: Max Time to $\text{V}_{\text{BUSMOD}} = 1.0\ \text{V}$ ⁽¹⁴⁾ Min Time to $\text{V}_{\text{BUSMOD}} = 3.7\ \text{V}$ ⁽¹⁴⁾	t_{DLYHVFO}	1.8 1.8	– –	14 14	μs
RECEIVER RXD					
Receive Delay Time ($5.0\ \text{V} \leq \text{V}_{\text{BATT}} \leq 26.5\ \text{V}$) Awake	t_{RDLY}	0.2	–	1.0	μs
Receive Delay Time (BUS Rising to RXD Falling, $5.0\ \text{V} \leq \text{V}_{\text{BATT}} \leq 26.5\ \text{V}$) Sleep	t_{RDLYSL}	10	–	70	μs
CNTL					
CNTL Falling Delay Time ($5.0\ \text{V} \leq \text{V}_{\text{BATT}} \leq 26.5\ \text{V}$) (33897/A/C/T only)	t_{CNTLFDLY}	300	–	1000	ms

Notes

14. V_{BUSMOD} is the voltage at the BUSMOD node in [Figure 7](#), page 15.

TIMING DIAGRAMS

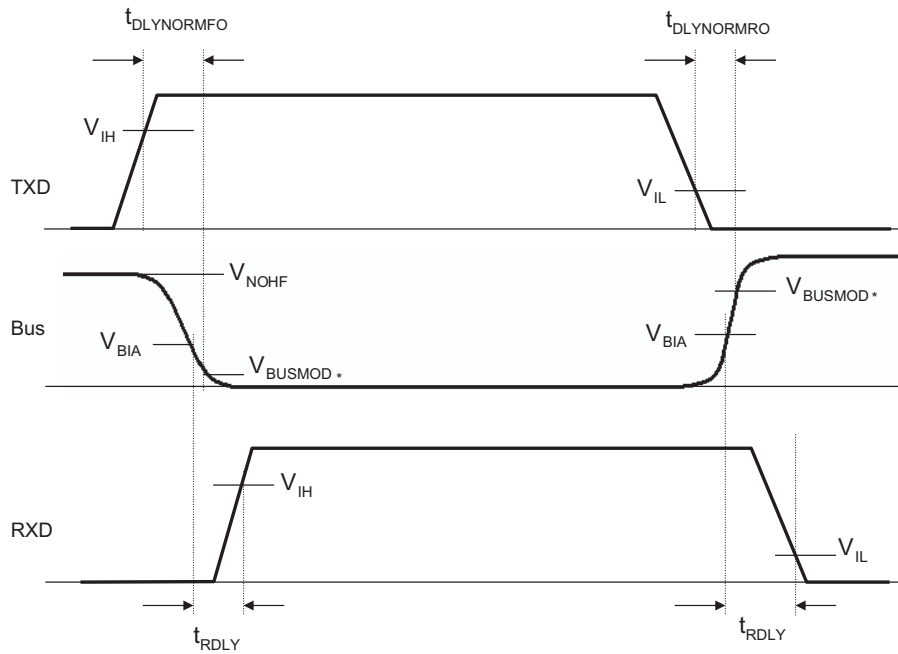

* V_{BUSMOD} is the voltage at the BUSMOD node in Figure 7.

Figure 5. TXD, Bus and RXD Waveforms in Normal Mode

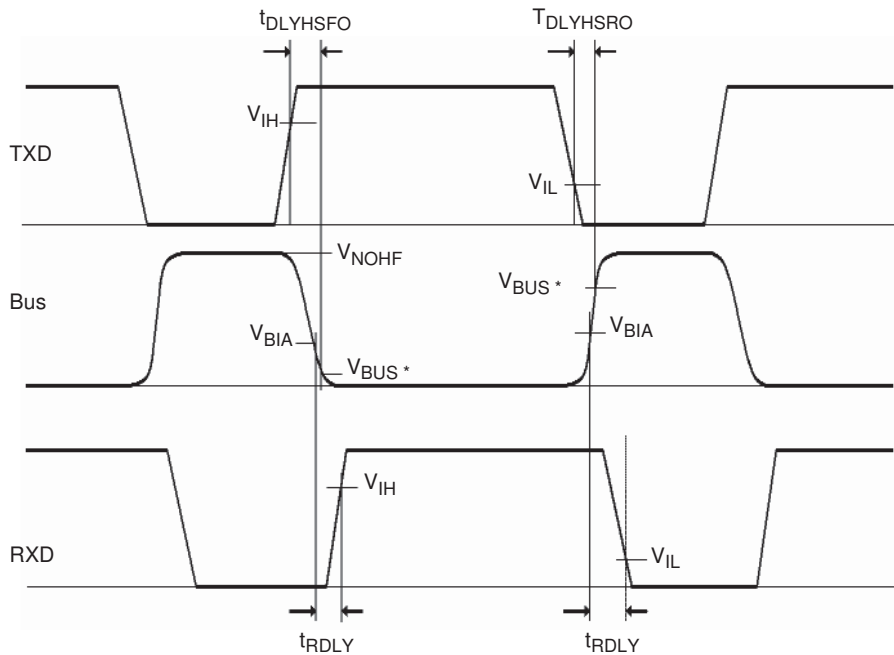

* V_{BUS} is the voltage at the BUS terminal in Figure 8.

Figure 6. TXD, Bus and RXD Waveforms in High Speed Mode

FUNCTIONAL DESCRIPTION

INTRODUCTION

The 33897 Series is intended for use as a physical layer device in a Single Wire CAN communications bus. Communications takes place from a single terminal over a single wire using a common ground for a current return path. Two data rates are available, with the high rate used for factory or assembly line communications and the lower for

actual system communications where the radiated EMI of the higher rate could be an issue.

Two Pins control the mode of operation (sleep, low-speed, high-speed, and high-voltage wake-up).

FUNCTIONAL PIN DESCRIPTION

The 33897 Series is intended to be used with an MCU to control its operation and to process and generate the data for the bus.

GROUND PINS (33897/A/C/T)

The four ground PINS are not only for electrical conduction, their number and locations at each of the four corners serve also to remove heat from the IC. The biggest benefit of this is obtained by putting a lot of copper on the PCB in this area and, if ground is an internal layer, by adding numerous plated-through connections to it with the largest diameter holes the layout can use.

TXD DATA

The data driven onto the SWCAN bus is inverted from the TXD terminal. A "1" driven on TXD will result in an undriven (recessive) state (bus at near zero volts). When the TXD terminal is low, the output goes to a driven state. The voltage and waveshaping in the driven state is determined by the levels on the MODE0 and MODE1 Pins (refer to [Table 6](#)).

Table 6. Mode Control Logic Levels

Logic Level		Operation
MODE0	MODE1	
0	0	Sleep Mode
0	1	High Voltage Wake-Up Mode
1	0	High Speed Mode
1	1	Normal Mode

MODE CONTROL

The MODE Pins control the transmitter filtering and BUS voltage and the IC sleep mode operation. [Table 6](#) shows the mode versus the logic levels on MODE0 and MODE1.

The MODE0 and MODE1 Pins have a weak pulldown in the IC so that in case the Pins are not driven, the device will enter the sleep mode. This is usually the situation as the MCU comes out of reset, before the driving signals have been configured as outputs.

RXD Data

The data received on the bus is translated to logic levels on this terminal. This terminal is a logic high when the bus is in the recessive state (near zero volts) and is logic low when the bus is in either the normal or high-voltage dominant state.

This is an open-drain type of output that requires an external resistor to pull it up. When the device is in sleep mode, the output will be off unless a high-voltage wake-up level is detected on the bus. If the wake-up level is detected, the output will be driven by the data on the bus. If the level of the data returns to normal level, the output will return to off after a short delay unless a non-sleep mode condition is set by the MCU.

LOAD Switch

This switch is on in all operating modes unless a loss of ground is detected. If this happens, the switch is opened and the resistor normally attached to its terminal will no longer pass current to or from the bus.

CNTL Output (33897/A/C/T ONLY)

This logic level signal is used to control a V_{CC} regulator. When the output is low, the V_{CC} regulator is expected to shutdown. This is normally used to shut down the MCU and all the devices powered by V_{CC} when the IC is in sleep mode. This is done to save power. When the part is taken out of the sleep mode by the higher-than-normal bus voltage, this terminal is asserted high and the V_{CC} regulator brings its output up to the regulated level. This starts the MCU, which controls the mode of the IC. The MCU must change the mode signals to non-sleep mode levels in order to keep this terminal from going low. There is a delay to allow the MCU to fully wake up and take control after the high-voltage signaling is removed before the level on this output returns low. After a delay time, even if the bus is at high voltage, the IC will return to sleep mode if both MODE Pins are low.

VBATT Input

This power input is not reverse battery protected and should use an external diode to protect it from damage owing to reverse battery if this protection is desired. The voltage drop of the diode must be taken into consideration when the operating range of the system is being determined. This

diode is generally used to protect the entire module from reverse battery and should be selected accordingly.

BUS I/O

This input/output may require electrostatic discharge (ESD) and/or EMI external circuitry. A set of components is

shown in the simplified application diagrams on [page 16](#) of this datasheet. The value of the capacitor should be adjusted downward in direct proportion to the added capacitance of the ESD or EMI circuits. The series resistance of the inductor should be kept below $3.5\ \Omega$ to prevent its voltage drop from significantly degrading system noise margins.

FUNCTIONAL BLOCK DIAGRAM COMPONENTS

Timer OSC

This circuit generates a 500 kHz signal to be used for internal logic. It is the reference for some of the required delays.

Timers

This circuit contains the timing logic used to hold the CNTL active for the required time after the conditions for sleep mode have been met. It is also used to keep the TXD driver active for a period of time after it has generated a passive level on the bus.

Mode Control

This circuit contains the control logic for the various operating modes and conditions required for the IC.

BUS RCVR

This circuit translates the levels on the BUS terminal to a CMOS level indicating the presence of a logic [0] or a logic [1]. It also determines the presence of a high-voltage wake-up (HVWU) signal that is passed to Mode Control and Timers circuits. An analog filter is used to “de-glitch” the high-voltage wake-up signal and prevent false exits from the sleep mode.

TXD BUS DRVR

This circuit drives the BUS. It can drive it with the higher voltage wake-up signals when enabled by the Mode Control circuit. It can also provide waveshaping for reduced EMI or not provide it for the higher data rate mode. The actual data is received on TXD at CMOS logic levels, then translated by this circuit to the necessary operating voltages.

Undervoltage Detect

This circuit monitors internal operating voltage to assure proper operation of the part. If a low-voltage condition is detected, it sends a signal to disable the BUS RCVR and TXD BUS DRVR circuits. This prevents incorrect data from being put on the bus or sent to the MCU.

Load Switch

The LOAD switch provides a path for an external resistor connected to the BUS to be connected to ground. When a loss of ground is detected, this switch is opened to prevent the current that would normally be flowing to the ground from the module from going back through the load resistor and raising the bus level. The circuit is opened when the voltage between GND and VBATT becomes too low as would be the case if module ground were lost.

BUS LOADING PARAMETERS

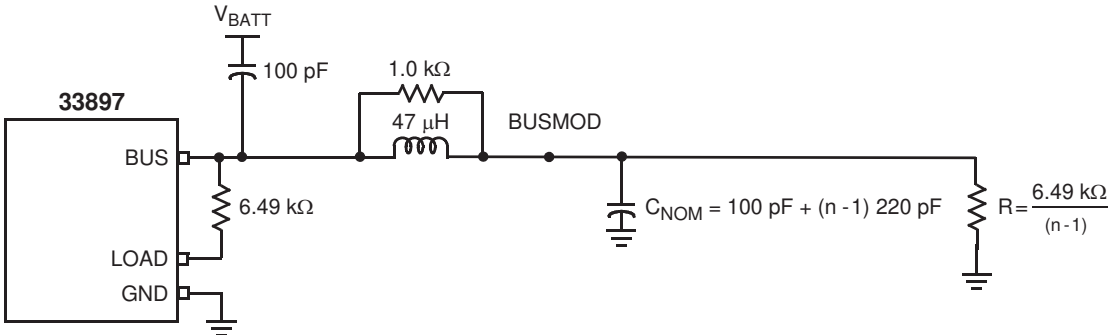

Note: The letter “n” represents the number of nodes in the system.

Figure 7. Transmitter Delays in Normal and Transmit High-Voltage Wake-Up Modes

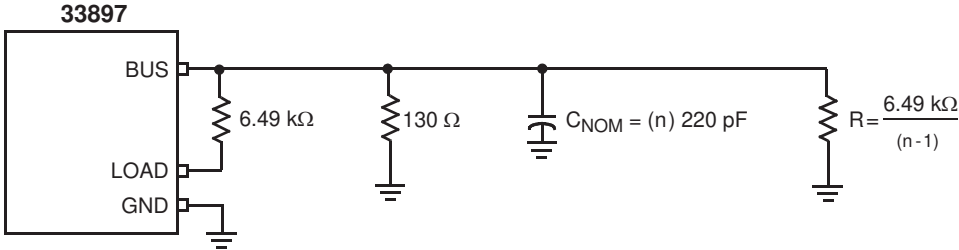

Note: The letter “n” represents the number of nodes in the system.

Figure 8. Transmitter Delays in Transmit High-Speed Mode

TYPICAL APPLICATIONS

The 33897/A/C/T can be used in applications where the module includes a regulator that has the capability of going into Sleep mode by having an Enable terminal. See [Figure 9](#). When the module's regulator is in sleep mode, the module is turned off. The module waits for a defined wake-up voltage

level on the bus. This wake-up voltage will activate the control line, which enables the regulator and turns the module back on. This 33897/A/C/T feature allows the module to be more energy efficient since the current consumption is significantly lowered when it goes into sleep mode.

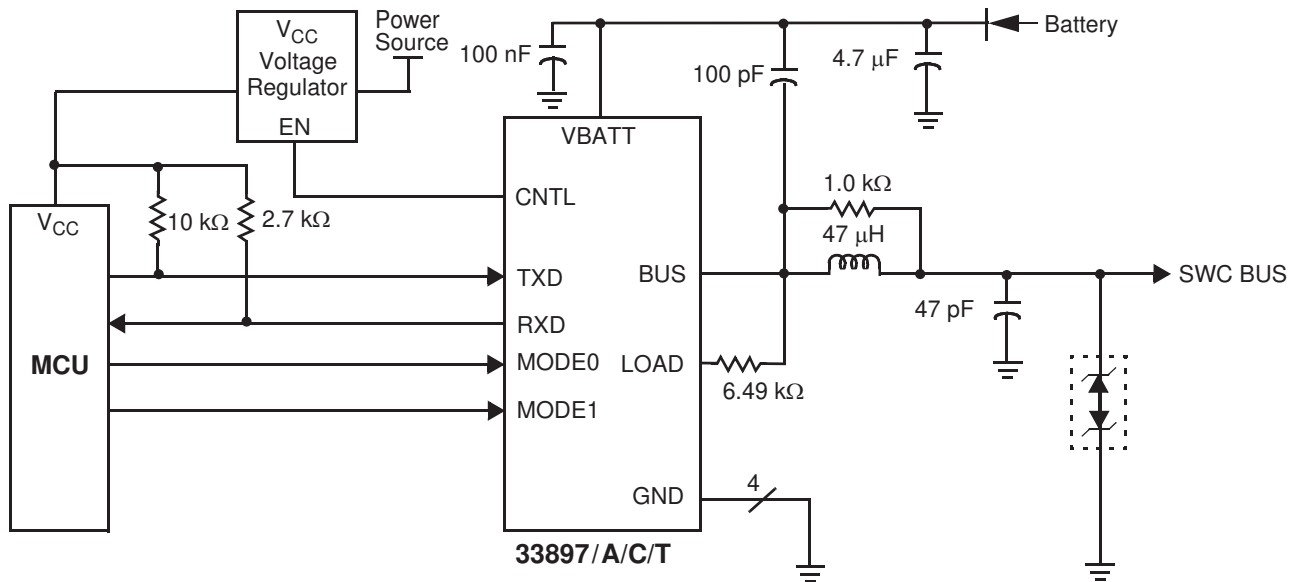

Figure 9. 33897/A/C/T Typical Application Schematic

The 33897B/D do not have a control terminal to enable the module's regulator. See [Figure 10](#). The 33897B/D can be used in applications where board space is limited and there

is no need for the module to have control over its regulator via the transceiver.

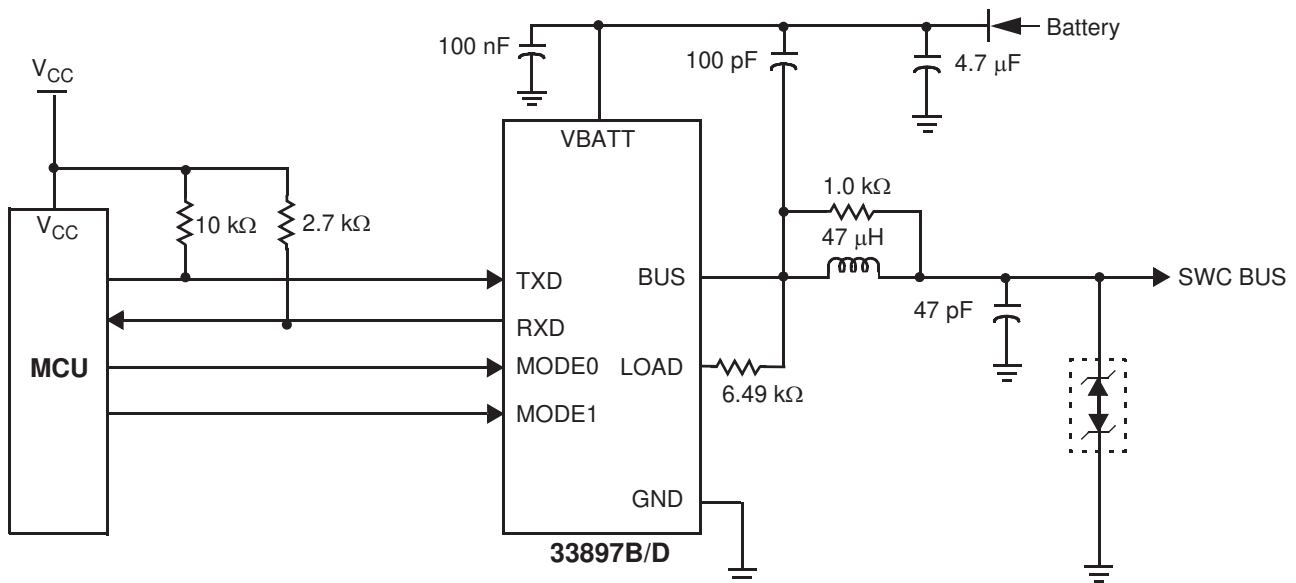
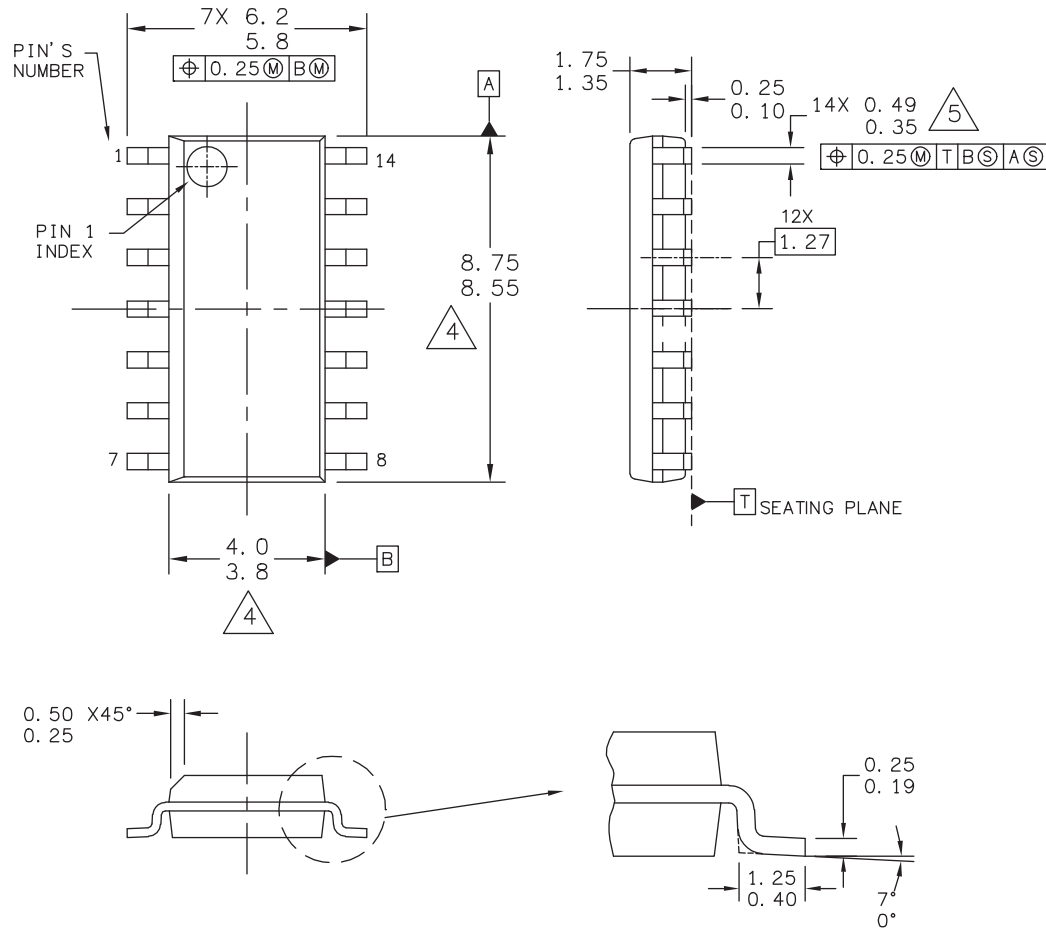

Figure 10. 33897B/D Typical Application Schematic

PACKAGING

PACKAGE DIMENSIONS

Important: For the most current Package revision, visit www.freescale.com and perform a Keyword Search on the "98A" drawing number below.



© FREESCALE SEMICONDUCTOR, INC. ALL RIGHTS RESERVED.	MECHANICAL OUTLINE	PRINT VERSION NOT TO SCALE	
TITLE: 14LD SOIC N/B, 1.27 PITCH CASE-OUTLINE	DOCUMENT NO: 98ASB42565B	REV: H	
	CASE NUMBER: 751A-03	19 JUL 2005	
	STANDARD: JECDEC MS-012AB		

D SUFFIX
EF (Pb-FREE) SUFFIX
14-TERMINAL SOICN
PLASTIC PACKAGE
98ASB42565B
ISSUE H

PACKAGE DIMENSIONS (CONTINUED)

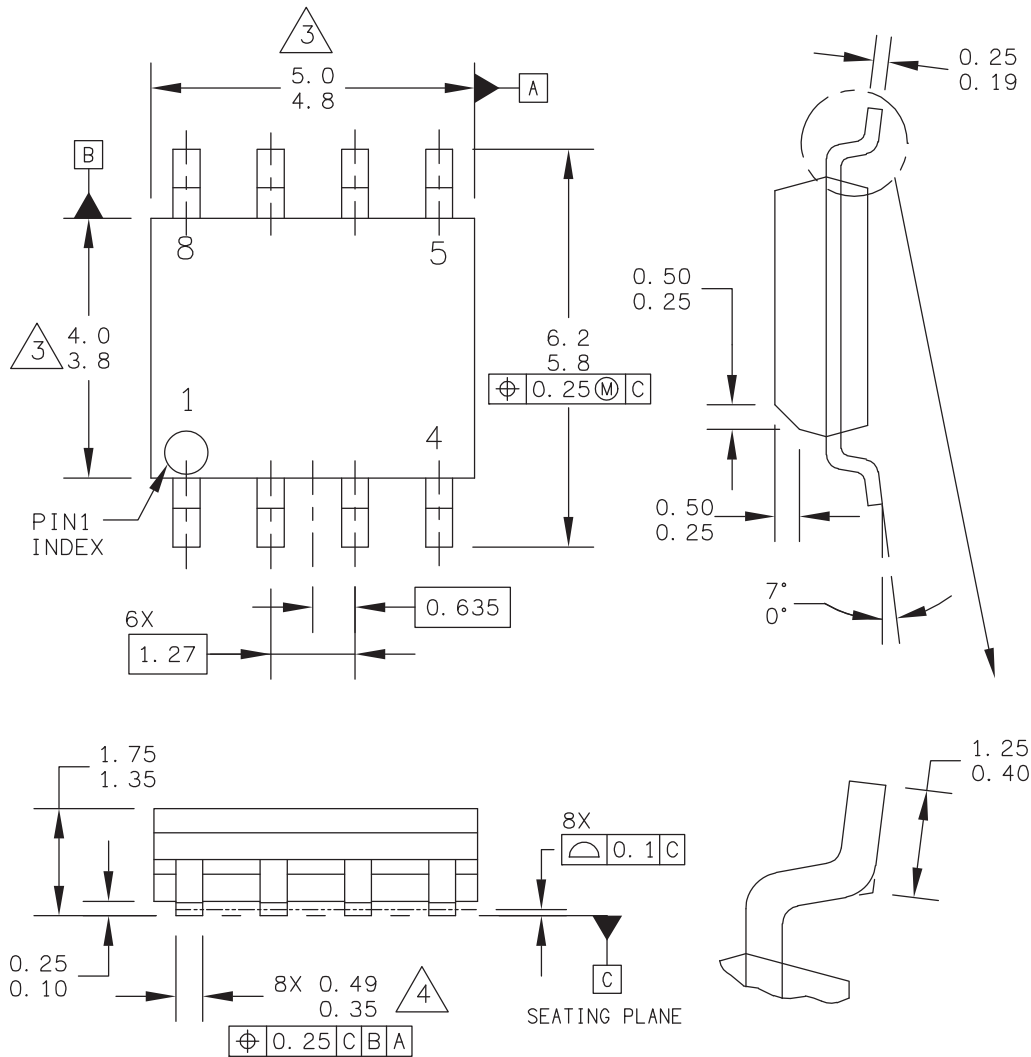

© FREESCALE SEMICONDUCTOR, INC. ALL RIGHTS RESERVED.	MECHANICAL OUTLINE	PRINT VERSION NOT TO SCALE	
TITLE: 8LD SOIC NARROW BODY	DOCUMENT NO: 98ASB42564B	REV: U	
	CASE NUMBER: 751-07	07 APR 2005	
	STANDARD: JEDEC MS-012AA		

EF (Pb-FREE) SUFFIX
8-TERMINAL SOICN
PLASTIC PACKAGE
98ASB42564B
ISSUE U

REVISION HISTORY

REVISION	DATE	DESCRIPTION OF CHANGES
9.0	5/2005	<ul style="list-style-type: none"> • Converted to Freescale format • Added A & B Versions • Updated Device Variation Table, and Note “** Recommended device for all new designs” • Added EF (Pb-Free) Devices, and higher soldering temperature
10.0	8/2005	<ul style="list-style-type: none"> • Implemented Revision History page • Updated Simplified Application Diagrams • Updated Typical Application Schematic
11.0	12/2005	<ul style="list-style-type: none"> • Added 33897C and D versions and Timing Diagrams
12.0	1/2006	<ul style="list-style-type: none"> • Updated Table 4, Static Electrical Characteristics - LOAD and BUS parameters • Updated Ordering Information.
13.0	6/2006	<ul style="list-style-type: none"> • Removed “Unless otherwise noted” from Static Electrical Characteristics & Dynamic Electrical Characteristics table introductions
14.0	8/2006	<ul style="list-style-type: none"> • Added Part Numbers MC33897TD and MC33897TEF to Ordering Information on Page 1. • Added 33897T to Table 1, Device Variations on Page 3, Referencing Electrical Changes per Errata MC33897TER, Revision 3 and specifying ESD variations
15.0	10/2006	<ul style="list-style-type: none"> • Removed Part Numbers MC33897TD/R2, MC33897TEF/R2, MC33897CLEF/R2, PC33897CLEF/R2, MC33897DLEF/R2, and PC33897DLEF/R2 • Added Part Numbers MCZ33897EF/R2, MCZ33897TEF/R2, MCZ33897AEF/R2, MCZ33897CEF/R2, MCZ33897BEF/R2, and MCZ33897DEF/R2 to the Ordering Information block on Page 1. • Updated Device Variations on page 3 for “T” suffix products • Split out Human Body Model on page 6 to differentiate between T and non-T versions • Added Undervoltage Hysteresis on page 7 • Removed Peak Package Reflow Temperature During Reflow (solder reflow) parameter from Maximum Ratings on page 6. Added note with instructions to obtain this information from www.freescale.com.
16.0	6/2007	<ul style="list-style-type: none"> • Removed watermark, “Advance Information” from page 1.

How to Reach Us:

Home Page:

www.freescale.com

E-mail:

support@freescale.com

USA/Europe or Locations Not Listed:

Freescale Semiconductor
Technical Information Center, CH370
1300 N. Alma School Road
Chandler, Arizona 85224
+1-800-521-6274 or +1-480-768-2130
support@freescale.com

Europe, Middle East, and Africa:

Freescale Halbleiter Deutschland GmbH
Technical Information Center
Schatzbogen 7
81829 Muenchen, Germany
+44 1296 380 456 (English)
+46 8 52200080 (English)
+49 89 92103 559 (German)
+33 1 69 35 48 48 (French)
support@freescale.com

Japan:

Freescale Semiconductor Japan Ltd.
Headquarters
ARCO Tower 15F
1-8-1, Shimo-Meguro, Meguro-ku,
Tokyo 153-0064
Japan
0120 191014 or +81 3 5437 9125
support.japan@freescale.com

Asia/Pacific:

Freescale Semiconductor Hong Kong Ltd.
Technical Information Center
2 Dai King Street
Tai Po Industrial Estate
Tai Po, N.T., Hong Kong
+800 2666 8080
support.asia@freescale.com

For Literature Requests Only:

Freescale Semiconductor Literature Distribution Center
P.O. Box 5405
Denver, Colorado 80217
1-800-441-2447 or 303-675-2140
Fax: 303-675-2150
LDCForFreescaleSemiconductor@hibbertgroup.com

RoHS-compliant and/or Pb-free versions of Freescale products have the functionality and electrical characteristics of their non-RoHS-compliant and/or non-Pb-free counterparts. For further information, see <http://www.freescale.com> or contact your Freescale sales representative.

For information on Freescale's Environmental Products program, go to <http://www.freescale.com/epp>.

Information in this document is provided solely to enable system and software implementers to use Freescale Semiconductor products. There are no express or implied copyright licenses granted hereunder to design or fabricate any integrated circuits or integrated circuits based on the information in this document.

Freescale Semiconductor reserves the right to make changes without further notice to any products herein. Freescale Semiconductor makes no warranty, representation or guarantee regarding the suitability of its products for any particular purpose, nor does Freescale Semiconductor assume any liability arising out of the application or use of any product or circuit, and specifically disclaims any and all liability, including without limitation consequential or incidental damages. "Typical" parameters that may be provided in Freescale Semiconductor data sheets and/or specifications can and do vary in different applications and actual performance may vary over time. All operating parameters, including "Typicals", must be validated for each customer application by customer's technical experts. Freescale Semiconductor does not convey any license under its patent rights nor the rights of others. Freescale Semiconductor products are not designed, intended, or authorized for use as components in systems intended for surgical implant into the body, or other applications intended to support or sustain life, or for any other application in which the failure of the Freescale Semiconductor product could create a situation where personal injury or death may occur. Should Buyer purchase or use Freescale Semiconductor products for any such unintended or unauthorized application, Buyer shall indemnify and hold Freescale Semiconductor and its officers, employees, subsidiaries, affiliates, and distributors harmless against all claims, costs, damages, and expenses, and reasonable attorney fees arising out of, directly or indirectly, any claim of personal injury or death associated with such unintended or unauthorized use, even if such claim alleges that Freescale Semiconductor was negligent regarding the design or manufacture of the part.

Freescale™ and the Freescale logo are trademarks of Freescale Semiconductor, Inc. All other product or service names are the property of their respective owners.

© Freescale Semiconductor, Inc., 2006. All rights reserved.