

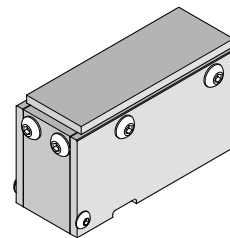

**2-by-1  
QSFP+ and zQSFP+  
Insertion Tool**

**Application Tooling  
Specification Sheet**



**Order No. 62202-5300**

**FEATURES**

- Lightweight tool used in the insertion of a QSFP+ and zQSFP+ connector in a PCB
- Inserts connector to a PCB without damage to the board
- Use tool 62202-5210 for removing connectors

**SCOPE**

Products: Quad Small Form-factor Pluggable Plus (QSFP+) and zQSFP+ Cage Assembly, 2-by 1 Multi-Port Connector, 2 Press Fit Rear Legs, Elastomeric Gasket for SAN Applications.

Series No.	Connector Order No.					
76871	76871-0001	76871-0002	76871-0003	76871-0004	76871-0005	76871-0006
	76871-0007	76871-0008	76871-5001	76871-5002	76871-5003	76871-5004
171208	171208-0001	171208-0002	171208-0003			
171722	171722-0001	171722-1000	171722-1001	171722-1002	171722-1003	171722-1062
	171722-1802	171722-6001				

**Notes:**

1. See the following pages for tooling operation instructions.
2. These tools require a "Keep Out Zone" around the connector free of components. The rear of the connector should be .197" (5.0mm). The right and left sides should be .14" (3.5mm). See Figure 1.

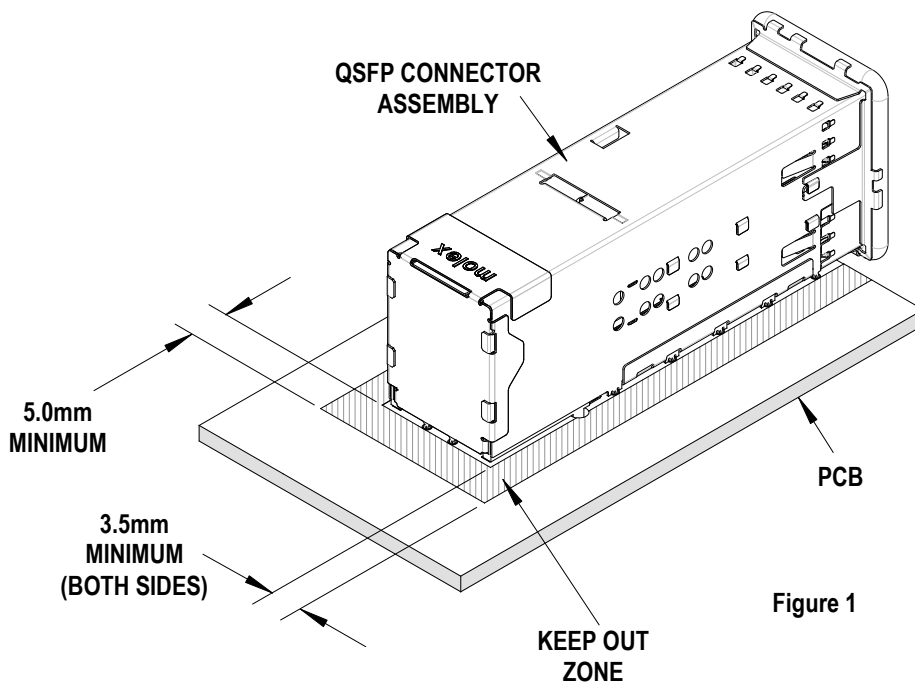

Figure 1

## Description

The following Instructions are used for inserting the 2 by 1 connector into a PCB.

## Operation

1. Place a connector assembly on the PCB.
2. Place the tool on the connector assembly (closed end to the back end of the connector). See Figure 2.
3. Place tool, connector, and PCB, in a press of suitable size and force, and seat the connector assembly as shown. The support plate (furnished by the customer) under the PCB must have clearance for the connector pins as they pass through the PCB.

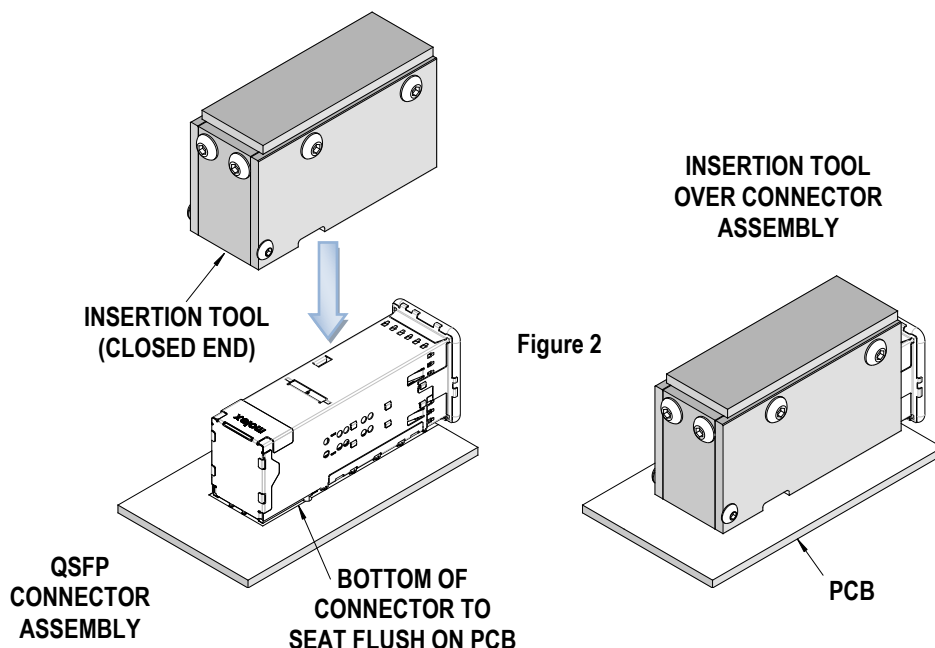

The support plate (furnished by the customer) under the PCB must have clearance for the connector pins as they pass through the PCB.

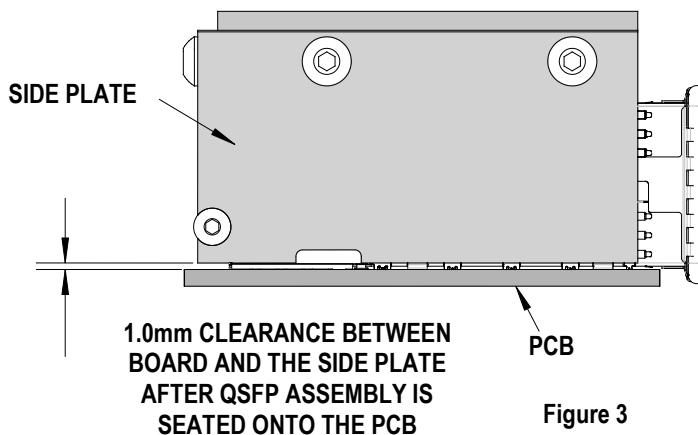

## Clearance

Use this tool only with a press that has a pre-determined shut height when seating a QSFP Assembly on a PCB. See figure 3. Allowing the Press-In Tool to stop on the board will result in damage the QSFP cage and terminals being over seated.

**CAUTION:** Molex application tooling specifications are valid only when used with Molex connectors and tooling.

## Contact Information

For more information on Molex application tooling please contact Molex at 1-800-786-6539.

Visit our Web site at <http://www.molex.com>