



Expertise Applied | Answers Delivered



POWR-GARD® PRODUCTS CATALOG

UL GENERAL INDUSTRIAL FUSES HIGH-SPEED FUSES MEDIUM VOLTAGE FUSES
BLOCKS & HOLDERS PRE-ENGINEERED PANELS & SWITCHES SOLAR PRODUCTS
AUTOMOTIVE & ELECTRONIC FUSES SURGE SUPPRESSION PRODUCTS

NEW POWR-SPEED® High-Speed Fuses



NEW 1500V Solar Fuses & Holders



SPNH Series
Solar Fuse



LFNH Series
Fuse Holder



LFNH Series
Fuse Terminal
Covers



LFPXV Series
Touch-Safe Fuse Holders

...plus 30% more fuse blocks!

1	Fuses		6	Fuse Blocks & Holders	
	Class L Fuses	8		LF Series Fuse Blocks Overview	89
	Class RK1 Fuses	13		Class J Fuse Blocks	91
	Class RK5 Fuses	16		Class H, K5 & R Fuse Blocks	94
	Class K5 Fuses	20		Class T Fuse Blocks	100
	Class J Fuses	21		Class G Fuse Blocks	105
	Class T Fuses	24		Class CC/CD & Midget Fuse Blocks	107
	Class G Fuses	26		LF Series Fuse Block Covers	112
	Class CC/CD Fuses	27		Solar Rated Fuse Blocks	113
	UL Supplemental/10 x 38 Fuses	30		Dead Front Fuse Holders	119
2	Electronic Fuses & Automotive Blade			Miscellaneous Fuse Blocks & Holders	120
	Glass/Electronic Fuses	33		High-Speed Semiconductor Fuse Blocks	128
	Blade/Automotive Fuses	36		Distribution & Splicer Blocks	131
				In-Line Fuse Holders	149
3	Medium Voltage Fuses		7	Pre-Engineered Solutions	
	Medium Voltage Fuses Overview	39		LCP Fused Selective Coordination Panel	157
	R-Rated Medium Voltage Fuses	40		LPS Series POWR-Switch (Shunt Trip Disconnect)	159
	E-Rated Medium Voltage Fuses	42	8	Suppression Products	
	Medium Voltage Live Parts	48		Industrial Varistor Products	163
4	Telecommunication Products			Surge Suppression Fuses	165
	Telecommunications Power Fuses	49		BVSP Suppression Fuses	166
5	Special Purpose Fuses		9	Miscellaneous Accessories	
	Solar Products Overview	57		Fuse Reducers	168
	1500 Vdc Solar Rated Fuses	58		Box Cover Units	169
	1000 Vdc Solar Rated Fuses	61		Fuse Replacement & Custom Kit (FRCK Series)	170
	Forklift/Stud Mounted Fuses	64		Fuse Display & Cabinet	171
	Plug Fuses	65	10	Technical Application Guide	
	MEGA® Bolt-Down Fuses	65		Fuseology Fundamentals	173
	In-Line Fuses & Holders	66		Selection Considerations	174
	Cable Limiters	67		Time-current Curves & Peak Let-through Charts	179
	Cylindrical Fuses	68		Selective Coordination	181
	OEM Custom Products	69		UL/CSA Fuse Classes & Applications	184
	High-Speed Square Body Fuses	71		Terms & Definitions	186
	High-Speed Round-Body Fuses	76		Motor Protection Tables	193
	Traditional High-Speed Fuses	82		Condensed Fuse Cross Reference	196
				Alphanumeric Index of Catalog Numbers	197

1

2

3

4

5

6

7

8

9

10

FUSE CLASS AND SELECTION CHART

UL CLASS	LITTELFUSE SERIES	OVERLOAD CHARACTERISTICS	AC RATINGS			DC RATINGS			RECOMMENDED FUSE BLOCKS AND FUSE HOLDERS	FUSE SERIES PAGE NUMBERS
			VOLTAGE (VOLTS)	CURRENT (AMPERES)	INTERRUPTING (AMPERES)	VOLTAGE (VOLTS)	CURRENT (AMPERES)	INTERRUPTING (AMPERES)		
L	KLPC	Time-Delay	600	200 - 6000	200K / 300K*	480	200 - 6000	20,000	-	8
	KLLU	Time-Delay	600	601 - 4000	200,000	300	601 - 4000	20,000		9
	LDC	Fast-Acting	600	150 - 2000	200,000	600	150 - 2000	50,000		10
RK1	LLNRK	Time-Delay	250	0.1 - 600	200K / 300K*	125	0.1 - 600	20,000	LFR25	13
	LLSRK_ID	Time-Delay	600	0.1 - 600		300	0.1 - 600		LFR60	13
	LLSRK	Time-Delay	600	0.1 - 600		300	0.1 - 600		LFR60	13
	KLNR	Fast-Acting	250	1 - 600	125	1 - 600	LFR25		15	
	KLSR	Fast-Acting	600	1 - 600	200,000	250 300	1 - 30 35 - 600		LFR60	15
RK5	FLNR_ID	Time-Delay	250	35 - 600	200K / 300K*	125	35 - 600	20,000	LFR25	17
	FLNR		250	0.1 - 600		125	0.1 - 600		LFR25	17
	FLSR_ID		600	0.1 - 600		300	0.1 - 600		LFR60	17
	FLSR		600	0.1 - 600		300	0.1 - 600		LFR60	17
	IDSR		600	0.1 - 600		600	0.1 - 600		LFR60	16
J	JTD_ID	Time-Delay	600	0.8 - 600	200K / 300K*	300	0.8 - 100	20,000	LFB60 • LFPSJ	21
	JTD	Time-Delay	600	0.8 - 600		500	110 - 600			21
	JLS	Fast-Acting	600	1 - 600	200,000	-	-			-
T	JLLN	Fast-Acting	300	1 - 1200	200,000	160 125	1 - 60 70 - 1200	20,000	LFT30 • LSCR002 (700-800A)	24
	JLLS		600	1 - 1200		300	1 - 1200		LFT60 • LSCR002 (700-800A)	24
CC	CCMR	Time-Delay	600	0.2 - 30	200K / 300K*	250 250 300 500	0.2 - 2 4.5 - 10 2.25 - 4 12 - 30	20,000	L60030C • LFPS • LPSC • 571 • 572 • LEC • LEY	27
	KLDR	Time-Delay	600	0.1 - 30	200,000	300	0.1 - 30			28
	KLKR	Fast-Acting	600	0.1 - 30	200,000	300	0.1 - 30			28
CD	CCMR	Time-Delay	600	35 - 60	200K / 300K*	250	35 - 60	20,000	LFC60060	27
G	SLC	Time Lag	600 480	0.5 - 20 25 - 60	100,000	170	0.5 - 60	10,000	LFG600 (½ - 20A) LFG480 (25 - 60A)	26
	SPF	Solar	-	-	-	1000	1 - 30	20,000	LFPHV	62
SPFJ	600		125-450	200,000	1000	70 - 450	20K (70 - 200A) 10K (250 - 400A) 20K (450A)	LFB1000	63	
SPFI	-		-	-	1000	2 - 30	20,000	Not Required	61	
SPNH	-		-	-	1500	50 - 400	15,000	LFNH	60	
SPXV	-		-	-	1500	6 - 30	30,000	LPXV	58	
SPXI	-		-	-	1500	2.5 - 30	30,000	Not Required	59	
K5	NLN	Fast-Acting	250	1 - 600	50,000	250	1 - 600	20K (1 - 60A) 50K (70 - 600A)	LFB25	20
	NLS		600	1 - 600		600 500 400 600 500	1 - 7 8 - 30 35 - 60 70 - 200 225 - 600	20K (1 - 60A) 50K (70 - 600A)	LFB60	20
High-Speed	L15S	Very Fast-Acting	150	1 - 1000	200,000	150 100	1 - 60 70 - 1000	20,000	LSCR • 1LFS	81
	L25S		250	1 - 800		250 200	1 - 200 225 - 800			81
	L50QS		500	35-800		500	35-800	50,000	LSCR	71
	L50S			10 - 800		450	10 - 800	20,000	LSCR • 1LFS	77
	L60S		600	1 - 800		-	-	20,000	LSCR • 1LFS	81
	L70QS		700	35-800		700	35-800	50,000	LSCR	74
	L70S			10 - 800		650	10 - 800	20,000	LSCR • 1LFS	79
Midget (Supplementary)	BLF	Fast-Acting	250 125	0.5 - 15 20 - 30	10,000	-	-	-	L60030M • LFPSM • 571 • 572 • LEB • LEX	30
	BLN	Fast-Acting	250	1 - 30	10,000	-	-	-		30
	BLS	Fast-Acting	600 250	0.2 - 5 6 - 10	10,000	-	-	-		31
	FLA	Time-Delay	125	0.1 - 30	10,000	-	-	-		31
	FLM	Time-Delay	250	0.1 - 30	10,000	125	0.1 - 30	10,000		30
	FLQ	Time-Delay	500	0.1 - 30	10,000	300	0.1 - 30	10,000		30
	KLK	Fast-Acting	600	0.1 - 30	100K / 200K*	500	0.1 - 30	50,000		30
	KLKD	Fast-Acting	600	0.1 - 30	100,000	600	0.1 - 30	50,000		30
	KLQ	Time-Delay	600	1 - 6	10,000	-	-	-		31
FLU	Fast-Acting	1000	0.44/ 11	10,000 20,000	1000	0.44 11	10,000 20,000	LFPHV	31	
Plug	S00, T00	Time-Delay	125	0.25 - 30	10,000	-	-	-	Box Cover Units	65
	SLO, TLO	Medium Time-Delay	125	15 - 30	10,000	-	-	-		
Telecom	L17T	Fast-Acting	-	-	-	170	70 - 1200	100,000	LTFD Series	50
	TLN		-	-	-		1 - 600		LFR25	51
	TLS		-	-	-		1 - 125		LTFD101 • LFT30060 (cartridge)	52

* Littelfuse® self-certified

Littelfuse POWR-GARD® – Advanced Protection and Facility Savings



POWR-PRO®

Increase safety with POWR-PRO® Fuses

- Superior current-limitation from 1/10 – 6000 amperes
- Type 2 “No Damage” coordination with NEMA and IEC motor circuits
- Blown fuse indication (LLSRK_ID and JTD_ID Series)
- Compact motor protection (JTD/JTD_ID, CCMR Series)
- 300,000 AIR to meet trends toward higher SCCR

POWR-PRO® Look for the POWR-PRO® logo (or green fuse label) for superior protection

UL FUSE CLASS	POWR-PRO®	PAGE NUMBERS
Class L	KLPC & LDC	8, 10
Class RK1	LLNRK/LLSRK/LLSRK_ID	13
Class J	JTD/JTD_ID	21
Class CC / CD	CCMR (2/10–60)	27

MRO+™ PLUS

Material Reduction Opportunity Program

Increase safety and reduce inventory with MROplus

Your detailed reports will include:

- A streamlined current-limiting fuse inventory recommendation
- A guide to reducing electrical hazards within your facility
- An annual cost savings estimate
- A detailed cross reference

Contact your local sales representative for the MROplus request form.

Developing Next Generation 1500 Vdc Products for High And Low Current Ratings



POWR-GARD® SOLAR RATED PRODUCTS

This catalog incorporates our line of products designed specifically for the growing solar industry. As global standards are constantly changing, Littelfuse continues to develop circuit protection products that meet the requirements of the evolving photovoltaic market.



1500 Vdc Solar Products

SPXV Series Space-Saving Solar Fuse	58
SPXI Series In-Line Solar Fuse.....	59
SPNH Series 1500 Vdc Solar Fuse.....	60
LPIXV Series 1500 Vdc Fuse Holder.....	112
LFPXV Series 1500 Vdc Fuse Holder.....	113
New Products.....	littelfuse.com/solar



600-1000 Vdc Solar Products

SPFI Series 1000 Vdc In-Line Solar Fuse.....	61
SPF Series 1000 Vdc 10x38mm Fuse.....	62
SPFJ Series 1000 Vdc Class J Size Fuse	63
LPHV 1000 Vdc Fuse Holder.....	116
IDSR Series 600 Vdc Class RK5 Fuse.....	16
KLKD Series 600 Vdc 10x38mm Fuse.....	30



Look for this logo to indicate products that are used in solar applications. Visit our website littelfuse.com/solar for the latest updates on approvals, certifications, and new products.



FINDING
RELAYS IS
EASIER THAN
EVER!



Expanding our Line of Protection Relay Products

SymCom and SSAC the names you know and trust for Motor Protection, Pump Protection, and Timers have officially become part of the Littelfuse family. Over 1000 MotorSaver, PumpSaver, and SSAC parts have been added to Littelfuse.com. These robust products are used to control and protect applications in the Industrial Pumping, Irrigation, Water and Waste Water, HVAC/R, Oil and Gas, Food and Beverage, and Elevator markets.

Find all of our new and updated product pages at littelfuse.com/protection-relays.

New protection relay products include:



Enhanced Overload Relays

Protect motors and pumps from over/under current, over/under voltage, phase issues and ground faults. Communication modules also available.



Voltage/Phase Monitors

A cost-effective means to protect motors and pumps from voltage and phase issues.



Alternating Relays

Start and stop up to four pumps or use as a multi-channel switch. Intrinsically safe options available.



Pump Controllers

Balance runtime between loads and can be used in hazardous locations.



Load Sensors

Detect if the load is running or if there is an overload or underload condition.



Timers & Flashers

Delay starting and stopping loads, cycling, and sequencing of motors, pumps, compressors, heaters, and lighting.

To view the full line of protection relay products please visit www.littelfuse.com/protection-relays

Meet NEC® Requirements And Save Time With Pre-Engineered Solutions



LCP Series Coordination Panel

Ideal for circuits that require selective coordination such as emergency lighting circuits or essential electrical systems.

Features/Benefits

- Meets NEC® requirements
- Class CC & J fuse holders have open-circuit indication
- Fast-acting fuses protect against short circuits
- Feed through/sub feed lugs and 84-circuit configuration available
- Ground and neutral bars
- Copper bus standard

littelfuse.com/LCP

See page 157

LPS Series POWR-Switch

Individual fusible shunt trip disconnect switch easily coordinates with system's overcurrent protection. Typical applications include elevator circuits.

Features/Benefits

- Pre-engineered single unit makes procurement easy
- Reduces labor costs up to 66%
- Flexibility for a variety of applications
- Control power terminal block
- UL Listed package
- Cu and Al wire rated
- Lockable operating handle meets all code and safety requirements

littelfuse.com/LPS

See page 159

Section Overview

Since 1927 Littelfuse® has been providing fuses to the industrial market. You can continue to count on our manufacturing and supply chain processes to deliver high quality fuses when you need them. At Littelfuse we leverage our global reach to stay on top of the latest applications and standards. Whether your circuit protection needs are focused on OEM, MRO, or construction, we are committed to being your circuit protection partner and appreciate your business.

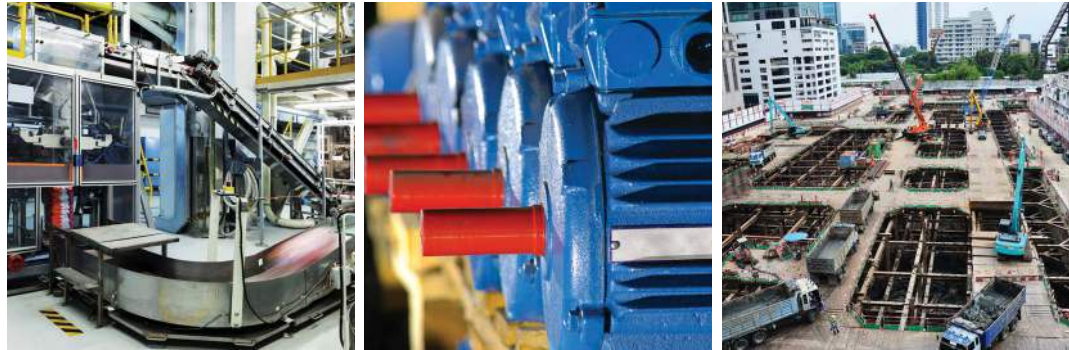

FUSES

Table of Contents

UL Class L Fuses.....	8
UL Class RK1 Fuses.....	13
UL Class RK5 Fuses.....	16
UL Class K5 Fuses	20
UL Class J Fuses	21
UL Class T Fuses.....	24
UL Class G Fuses	26
UL Class CC/CD Fuses	27
UL Supplemental Midget (10x38) Fuses.....	30

CLASS L - KLPC SERIES POWR-PRO® FUSES

POWR-PRO® 600 Vac • Time-Delay • 200-6000 A



1
UL Class L Fuses



Description

KLPC series POWR-PRO® fuses meet or exceed the most stringent project specifications, including silver links, silver-plated copper end bells, glass-reinforced melamine bodies, O-ring seals between body and end bells, and granular quartz fillers.

Applications

- Switchboard mains and feeders
- Motor control center mains
- Large motor branch circuits
- Protection of power circuit breakers

Features/Benefits

- POWR-PRO® Performance
- Best-in-class time-delay withstand
- Current-Limiting
- Easily coordinated with other system components
- 300 kA AC Interrupting Rating (self-certified)

Specifications

Voltage Ratings AC: 600 Vac or less
DC: 480 V

Ampere Range 200 – 6000 A

Interrupting Ratings AC: 200 kA rms symmetrical
300 kA rms symmetrical (Littelfuse self-certified)
DC: 20,000 A

Approvals AC: Standard 248-10, Class L
UL Listed 601–6000 A (File: E81895)
UL Recognized 200–600 A (File: E71611)
CSA Certified 601–6000 A (File: LR29862)
Federal Specifications 700–6000 A (QPL-W-F-1814)

DC: Littelfuse self-certified

Material Melamine body, Copper caps (silver plated)

Country of Origin Mexico

Ordering Information

AMPERE RATINGS					
200	500	800	1350	2000	3000
250	600	900	1400	2100	3500
300	601	1000	1500	2200	4000
350	650	1100	1600	2300	4500
400	700	1200	1800	2400	5000
450	750	1300	1900	2500	6000

SERIES	AMPERAGE	CATALOG NUMBER	ORDERING NUMBER
KLPC	800	KLPC800	KLPC800.X

Web Resources

Download TC Curves, CAD drawings and other technical information: littelfuse.com/klpc

Dimensions

Please refer to the Class L dimensions 12

Peak Let-Thru Curve

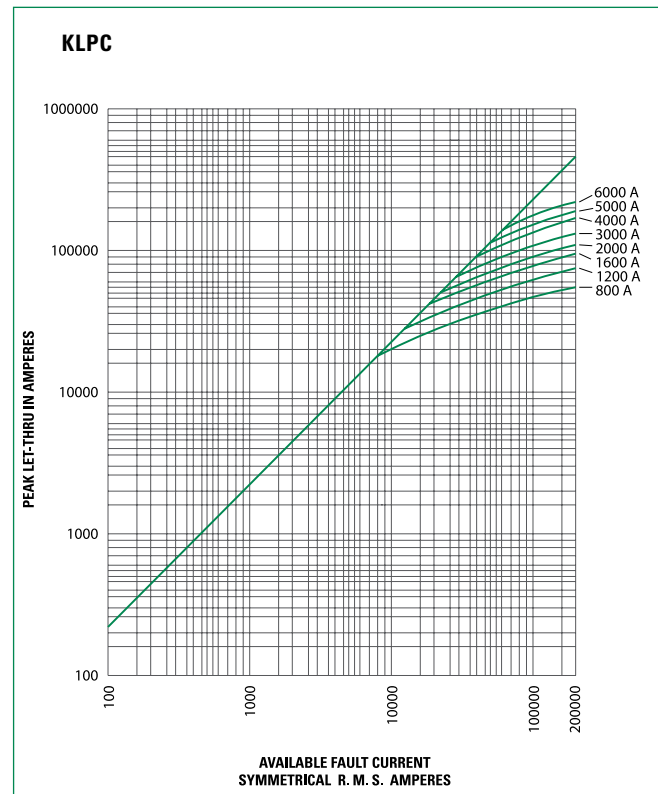

Note: For more information, see Peak Let-Thru Table on pg. 11

CLASS L - KLLU SERIES FUSES

600 Vac • Time-Delay • 601-4000 A



Description

KLLU series fuses meet or exceed UL requirements for UL Class L fuses. The KLLU series offers an economical alternative to KLPC POWR-PRO® fuse with a slightly higher peak let through current.

Applications

- Service switches
- Switchboard mains and feeders
- Motor control center mains
- Large motor branch circuits
- Circuit breaker protection

Features/Benefits

- Current-Limiting
- Easily coordinated with other system components
- 200 kA AC Interrupting Rating

Specifications

Voltage Ratings	AC: 600 Vac or less DC: 300 V
Ampere Range	601–4000 A
Interrupting Ratings	AC: 200 kA rms symmetrical DC: 20 kA rms symmetrical Standard 248-10, Class L UL Listed (File: E81895) CSA Certified (File: LR29862)
Approvals	DC: Littelfuse self-certified
Material	Melamine body, Copper caps (silver plated)
Country of Origin	Mexico

Ordering Information

AMPERE RATINGS					
601	750	1000	1400	1800	3000
650	800	1200	1500	2000	3500
700	900	1350	1600	2500	4000

SERIES	AMPERAGE	CATALOG NUMBER	ORDERING NUMBER
KLLU	601	KLLU601	KLLU601.X

Web Resources

Download TC Curves, CAD drawings and other technical information: littelfuse.com/kllu

Dimensions

Please refer to the Class L dimensions 12

Peak Let-Thru Curve

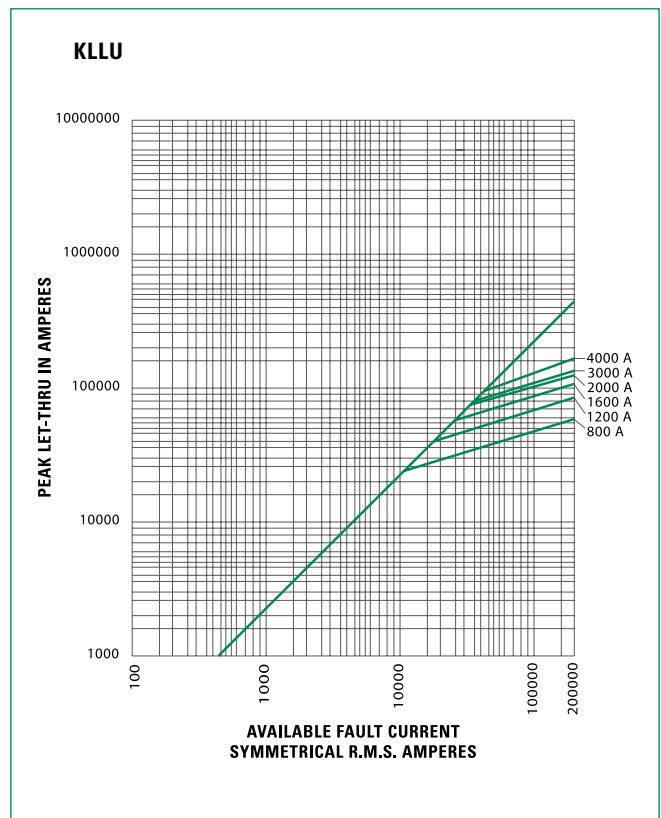

Note: For more information, see Peak Let-Thru Table on pg. 11

CLASS L - LDC SERIES POWR-PRO® FUSES

POWR-PRO® 600 Vac/dc • Fast Acting • 150-2000 A



1
UL Class L Fuses



Description

High DC voltage and interrupting ratings make the POWR-PRO® LDC ideal for DC applications. The DC interrupting performance exceeds UL listing requirements.

Applications

- Solar inverter and array protection
- UPS protection especially for large battery circuits
- DC distribution and variable speed drives
- Mass transit systems

Features/Benefits

- POWR-PRO® Performance
- Extremely Current-Limiting
- 600 Vac/dc rated
- 200 kA AC Interrupting Rating
- 50 kA DC Interrupting Rating

Specifications

Voltage Ratings	600 Vac/dc or less
Ampere Range	150–2000 A
Interrupting Ratings	AC: 200 kA rms symmetrical DC: 50 kA
Time Constant	16 ms
Approvals	Standard 248-10, Class L UL Listed 601–2000 A (File: E81895) UL Recognized 150–600 A (File: E71611) CSA Certified 800-2000 A (File: LR29862)
Material	Melamine body, Copper caps (silver plated)
Country of Origin	Mexico

Ordering Information

AMPERE RATINGS				
150	450	750	1201	1601
200	500	800	1300	1800
250	600	900	1350	1900
300	601	1000	1400	2000
350	650	1100	1500	
400	700	1200	1600	

SERIES	AMPERAGE	CATALOG NUMBER	ORDERING NUMBER
LDC	700	LDC700	0LDC700.X

Web Resources

Download TC curves, CAD drawings and other technical documents: littelfuse.com/ldc

Dimensions

Please refer to the Class L dimensions 12

Peak Let-Thru Curve

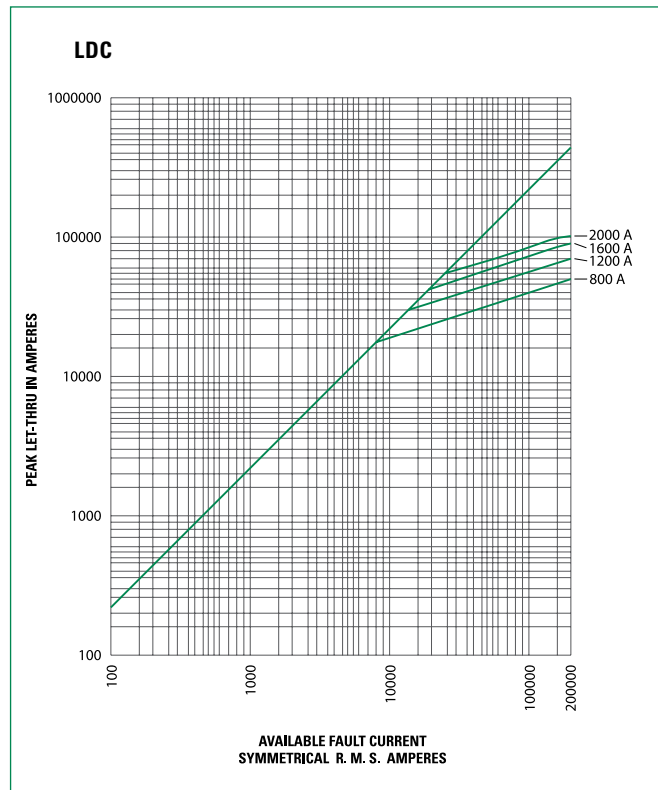

Note: For more information, see Peak Let-Thru Table on pg. 11

CLASS L CURRENT-LIMITING EFFECTS

1

UL Class L Fuses

Current-Limiting Effects of KLPC (600 V) Fuses

SHORT CIRCUIT CURRENT*	APPARENT RMS SYMMETRICAL CURRENT FOR VARIOUS FUSE RATINGS							
	800 A	1200 A	1600 A	2000 A	3000 A	4000 A	5000 A	6000 A
5,000	5,000	5,000	5,000	5,000	5,000	5,000	5,000	5,000
10,000	8,800	10,000	10,000	10,000	10,000	10,000	10,000	10,000
15,000	10,500	13,500	15,000	15,000	15,000	15,000	15,000	15,000
20,000	12,000	15,000	19,000	20,000	20,000	20,000	20,000	20,000
25,000	13,000	16,000	21,000	24,000	25,000	25,000	25,000	25,000
30,000	14,000	18,000	23,000	26,000	30,000	30,000	30,000	30,000
35,000	15,000	19,000	24,000	27,000	32,000	35,000	35,000	35,000
40,000	16,000	20,000	25,000	28,000	34,000	40,000	40,000	40,000
50,000	17,000	22,000	27,000	31,000	37,000	42,500	50,000	50,000
60,000	18,000	24,000	29,000	34,000	40,000	46,000	52,000	60,000
80,000	20,000	26,000	32,000	37,000	44,000	51,000	57,000	70,000
100,000	21,000	27,000	34,000	40,000	46,000	57,000	65,000	75,000
150,000	23,000	31,000	38,000	44,000	54,000	67,000	75,000	87,000
200,000	24,000	34,000	42,000	46,000	57,000	70,000	80,000	95,000

Current-Limiting Effects of KLLU (600 V) Fuses

SHORT-CIRCUIT CURRENT*	APPARENT RMS SYMMETRICAL CURRENT FOR VARIOUS FUSE RATINGS					
	800 A	1200 A	1600 A	2000 A	3000 A	4000 A
5,000	5,000	5,000	5,000	5,000	5,000	5,000
10,000	10,000	10,000	10,000	10,000	10,000	10,000
15,000	11,900	15,000	15,000	15,000	15,000	15,000
20,000	13,000	18,500	20,000	20,000	20,000	20,000
25,000	14,000	20,000	25,000	25,000	25,000	25,000
30,000	14,500	21,000	26,500	30,000	30,000	30,000
35,000	15,000	22,000	28,500	34,000	35,000	35,000
40,000	16,000	23,000	30,000	35,000	37,000	40,000
50,000	17,000	24,000	32,000	38,000	39,000	44,000
60,000	18,000	26,000	34,000	42,000	43,000	50,000
80,000	19,000	28,000	36,000	44,000	46,000	54,500
100,000	21,000	30,000	38,000	46,000	48,000	57,500
150,000	24,000	35,000	44,000	50,000	51,000	68,000
200,000	26,000	38,000	48,000	53,000	60,000	74,000

Current-Limiting Effects of LDC (600 V) Fuses

SHORT CIRCUIT CURRENT*	APPARENT RMS SYMMETRICAL CURRENT FOR VARIOUS FUSE RATINGS			
	800 A	1200 A	1600 A	2000 A
5,000	5,000	5,000	5,000	5,000
10,000	8,500	10,000	10,000	10,000
15,000	9,750	14,000	15,000	15,000
20,000	10,500	15,000	19,000	20,000
25,000	11,500	16,000	21,000	25,000
30,000	12,000	17,000	22,000	26,000
35,000	12,500	18,000	23,000	28,000
40,000	13,500	19,000	24,000	30,000
50,000	14,000	21,000	26,000	32,000
60,000	15,000	22,000	28,000	34,000
80,000	16,000	24,000	30,000	36,000
100,000	18,000	25,000	33,000	40,000
150,000	20,000	30,000	38,000	44,000
200,000	23,000	32,000	41,000	46,000

*Prospective RMS Symmetrical Amperes Short-Circuit Current
Note: Data derived from Peak Let-Thru Curves

CLASS L SERIES DIMENSIONS

1
UL Class L Fuses

Dimensions

AMPERES	FIG. NO.	DIMENSIONS INCHES (mm)												
		A	B	C	D	E	F	G	H	J	K	L	M	N
150-800	1	3 ³ / ₄ (95.3)	5 ³ / ₄ (146.1)	6 ³ / ₄ (171.5)	—	—	8 ⁵ / ₈ (219.1)	—	—	2 (50.8)	2 ¹ / ₂ (63.5)	3 ³ / ₈ (9.5)	5 ⁵ / ₈ x 1 ¹ / ₈ (15.9) x (28.6)	—
900-1200	2	3 ³ / ₄ (95.3)	5 ³ / ₄ (146.1)	6 ³ / ₄ (171.5)	9 ¹ / ₄ (235.0)	9 ¹ / ₂ (241.3)	10 ³ / ₄ (273.1)	—	—	2 (50.8)	2 ¹ / ₂ (63.5)	3 ³ / ₈ (9.5)	5 ⁵ / ₈ x 3 ³ / ₄ (15.9) x (19.1)	5 ⁵ / ₈ x 1 ¹ / ₈ (15.9) x (28.6)
1300-1600	2	3 ³ / ₄ (95.3)	5 ³ / ₄ (146.1)	6 ³ / ₄ (171.5)	9 ¹ / ₄ (235.0)	9 ¹ / ₂ (241.3)	10 ³ / ₄ (273.1)	—	—	2 ³ / ₈ (60.3)	3 (76.2)	7 ¹ / ₁₆ (11.1)	5 ⁵ / ₈ x 3 ³ / ₄ (15.9) x (19.1)	5 ⁵ / ₈ x 1 ¹ / ₈ (15.9) x (28.6)
1800-2000	2	3 ³ / ₄ (95.3)	5 ³ / ₄ (146.1)	6 ³ / ₄ (171.5)	9 ¹ / ₄ (235.0)	9 ¹ / ₂ (241.3)	10 ³ / ₄ (273.1)	—	—	2 ³ / ₄ (69.9)	3 ¹ / ₂ (88.9)	1 ¹ / ₂ (12.7)	5 ⁵ / ₈ x 3 ³ / ₄ (15.9) x (19.1)	5 ⁵ / ₈ x 1 ¹ / ₈ (15.9) x (28.6)
2100-2500	3	4 (101.6)	5 ³ / ₄ (146.1)	6 ³ / ₄ (171.5)	9 ¹ / ₄ (235.0)	9 ¹ / ₂ (241.3)	10 ³ / ₄ (273.1)	1 ⁵ / ₈ (41.3)	1 ³ / ₄ (44.5)	3 ¹ / ₂ (88.9)	5 (127.0)	3 ³ / ₄ (19.1)	5 ⁵ / ₈ x 3 ³ / ₄ (15.9) x (19.1)	5 ⁵ / ₈ x 1 ¹ / ₈ (15.9) x (28.6)
2501-3000	3	4 (101.6)	5 ³ / ₄ (146.1)	6 ³ / ₄ (171.5)	9 ¹ / ₄ (235.0)	9 ¹ / ₂ (241.3)	10 ³ / ₄ (273.1)	1 ⁵ / ₈ (41.3)	1 ³ / ₄ (44.5)	4 (101.6)	5 (127.0)	3 ³ / ₄ (19.1)	5 ⁵ / ₈ x 3 ³ / ₄ (15.9) x (19.1)	5 ⁵ / ₈ x 1 ¹ / ₈ (15.9) x (28.6)
3500-4000	4	4 (101.6)	5 ³ / ₄ (146.1)	6 ³ / ₄ (171.5)	9 ¹ / ₄ (235.0)	9 ¹ / ₂ (241.3)	10 ³ / ₄ (273.1)	1 ³ / ₄ (44.5)	3 ³ / ₄ (82.6)	4 ³ / ₄ (120.7)	5 ³ / ₄ (146.1)	3 ³ / ₄ (19.1)	5 ⁵ / ₈ x 1 ³ / ₈ (15.9) x (34.9)	5 ⁵ / ₈ x 1 ³ / ₈ (15.9) x (34.9)
4500-5000	5	4 (101.6)	5 ³ / ₄ (146.1)	—	9 ¹ / ₄ (235.0)	—	10 ³ / ₄ (273.1)	1 ⁵ / ₈ (41.3)	3 ³ / ₄ (82.6)	5 ¹ / ₄ (133.4)	7 ¹ / ₈ (181.0)	1 (25.4)	5 ⁵ / ₈ DIA. (15.9)	—
6000	5	4 (101.6)	5 ³ / ₄ (146.1)	—	9 ¹ / ₄ (235.0)	—	10 ³ / ₄ (273.1)	1 ⁵ / ₈ (41.3)	3 ³ / ₄ (82.6)	5 ¹ / ₄ (133.4)	7 ¹ / ₈ (181.0)	1 (25.4)	5 ⁵ / ₈ DIA. (15.9)	—

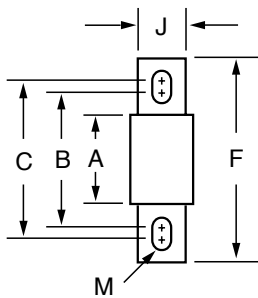

FIG. 1

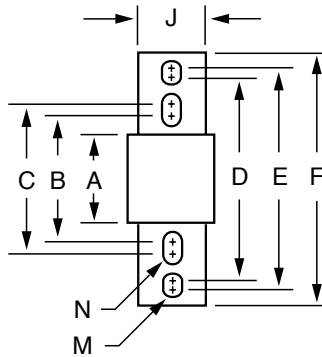

FIG. 2

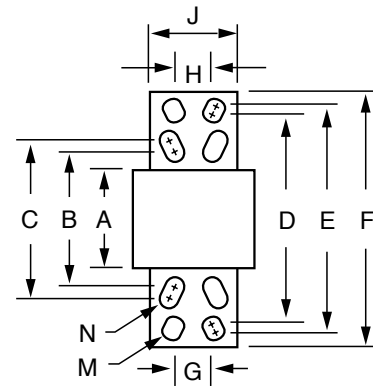

FIG. 3

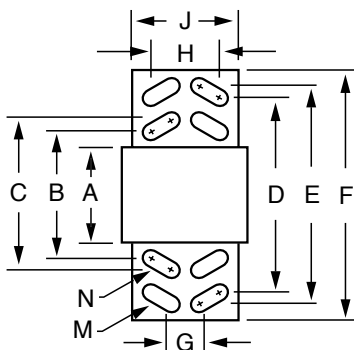

FIG. 4

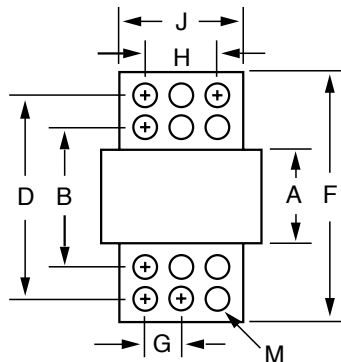
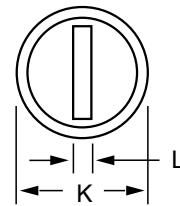

FIG. 5



CLASS RK1 – LLNRK • LLSRK • LLSRK_ID SERIES FUSES

POWR-PRO® 250/600 Vac • Dual Element • Time-Delay • 1/10-600 A



1

UL Class RK1 Fuses



Description

RK1 fuses are extremely current-limiting fuses meaning they greatly reduce or eliminate damage to circuits and equipment under short-circuit conditions. Replacing existing Class H, K and RK5 fuses with RK1 fuses is one of the easiest ways to immediately improve the protection of plant workers and equipment.

Applications

- All general purpose circuits
- Motors
- Transformers
- Safety upgrades

Features/Benefits

- POWR-PRO Performance
- Indication available
- Dual-element design
- Extremely Current-Limiting
- IEC Type 2 “No Damage” protection to IEC and NEMA type motor starters
- Indicating and DIN mount fuse holders available

Specifications

Voltage Ratings 600 Vac/300 Vdc (LLSRK/LLSRK_ID)
250 Vac/125 Vdc (LLNRK)

Interrupting Ratings AC: 200 kA rms symmetrical
300 kA rms symmetrical
(Littelfuse self-certified)

Ampere Range 1/10 – 600 A

Approvals AC: Standard 248-12, Class RK1
UL Listed (File: E81895)
CSA Certified (File: LR29862)
DC: Littelfuse self-certified
Federal Specification WF-1814
(QPL- W-F-1814)

Recommended Fuse Holders

LFR60 Series • LFR25 Series 94

Ordering Information

AMPERE RATINGS						
1/10	1	2 8/10	6 1/4	25	80	250
15/100	1 1/8	3	7	30	90	300
2/10	1 1/4	3 2/10	8	35	100	350
1/4	1 4/10	3 1/2	9	40	110	400
3/10	1 6/10	4	10	45	125	450
4/10	1 8/10	4 1/2	12	50	150	500
1/2	2	5	15	60	175	600
6/10	2 1/4	5 6/10	17 1/2	70	200	
8/10	2 1/2	6	20	75*	225	

Note: All LLSRK_ID fuses rated 1 amp and above are Indicator® fuses.
*75 A is only available for the 600 V.

600 V

TYPE	SERIES	AMP	CATALOG NUMBER	ORDERING NUMBER
INDICATING	LLSRK_ID	60	LLSRK060ID	LSRK060.TXID
NON-INDICATING	LLSRK	60	LLSRK060	LSRK060.T

250 V

TYPE	SERIES	AMP	CATALOG NUMBER	ORDERING NUMBER
NON-INDICATING	LLNRK	80	LLNRK080	LNRK080.V

Web Resources

Download TC Curves, CAD drawings and other technical information: littelfuse.com/llsrk
littelfuse.com/llnrk

Dimensions

Please refer to the Class R dimensions..... 19

Peak Let-Thru Curve (600 V)

LLSRK & LLSRKID

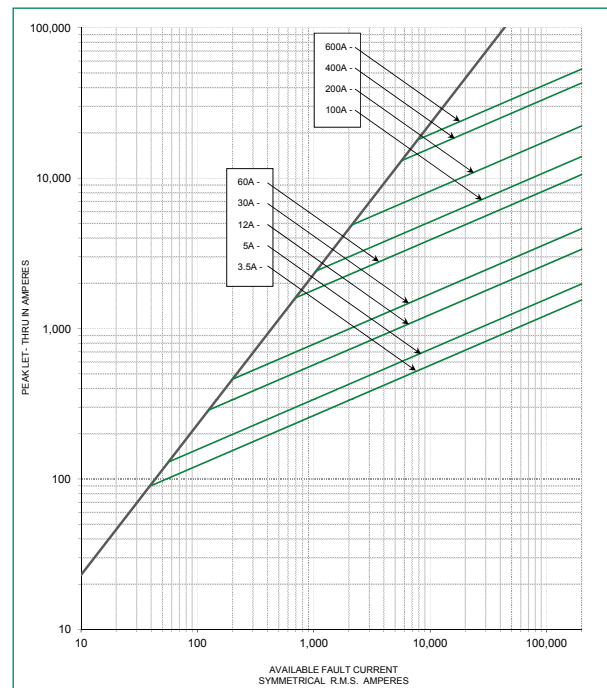

Note: For more information, see Peak Let-Thru Table on pg. 14

CLASS RK1 – LLNRK • LLSRK • LLSRK_ID SERIES FUSES

1
UL Class RK1 Fuses

Current-Limiting Effects of LLSRK and LLSRK_ID (600 V) Fuses

SHORT CIRCUIT CURRENT*	APPARENT RMS SYMMETRICAL CURRENT FOR VARIOUS FUSE RATINGS							
	3.5 A	5 A	12 A	30 A	100 A	200 A	400 A	600 A
5,000	196	251	427	586	1,764	2,821	-	-
10,000	247	316	538	739	2,222	3,554	6,850	8,489
15,000	283	362	616	845	2,544	4,069	7,842	9,718
20,000	312	399	677	930	2,800	4,478	8,631	10,696
25,000	336	430	730	1,002	3,016	4,824	9,297	11,522
30,000	357	456	776	1,065	3,205	5,126	9,880	12,244
35,000	376	481	816	1,121	3,374	5,397	10,401	12,889
40,000	393	502	854	1,172	3,528	5,642	10,874	13,476
50,000	423	541	919	1,263	3,800	6,078	11,714	14,516
60,000	450	575	977	1,342	4,038	6,459	12,448	15,426
80,000	495	633	1,075	1,477	4,445	7,109	13,700	16,979
100,000	533	682	1,158	1,591	4,788	7,658	14,758	18,290
150,000	610	781	1,326	1,821	5,481	8,766	16,894	20,936
200,000	671	859	1,460	2,005	6,032	9,648	18,594	23,043

Current-Limiting Effects of LLNRK (250 V) Fuses

SHORT CIRCUIT CURRENT*	APPARENT RMS SYMMETRICAL CURRENT FOR VARIOUS FUSE RATINGS					
	30 A	60 A	100 A	200 A	400 A	600 A
5,000	900	1,400	2,000	2,700	4,800	5,000
10,000	1,100	1,900	2,700	3,500	6,200	8,500
15,000	1,250	2,100	3,100	4,200	7,000	9,500
20,000	1,400	2,400	3,500	4,600	8,000	10,800
25,000	1,500	2,600	3,900	5,000	8,300	11,500
30,000	1,600	2,800	4,000	5,250	9,000	12,000
35,000	1,700	2,850	4,300	5,500	9,500	12,500
40,000	1,800	3,000	4,600	5,800	9,800	13,500
50,000	1,900	3,200	4,800	6,300	10,200	14,000
60,000	2,000	3,500	5,200	6,700	11,000	15,000
80,000	2,200	3,900	5,700	7,200	12,200	16,000
100,000	2,300	4,000	6,000	8,100	12,700	17,000
150,000	2,500	4,500	6,700	9,100	14,000	19,000
200,000	2,600	4,800	7,000	9,700	15,000	20,000

*Prospective RMS Symmetrical Amperes Short-Circuit Current
Note: Data derived from Peak Let-Thru Curves

LLSRK_ID Fuses—Quality Construction for performance you can rely on...

Littelfuse **LLSRK_ID** Fuses feature true dual-element construction. This robust design withstands repeated surges within rated time delay without opening needlessly, eliminating downtime caused by power surges or equipment demands.

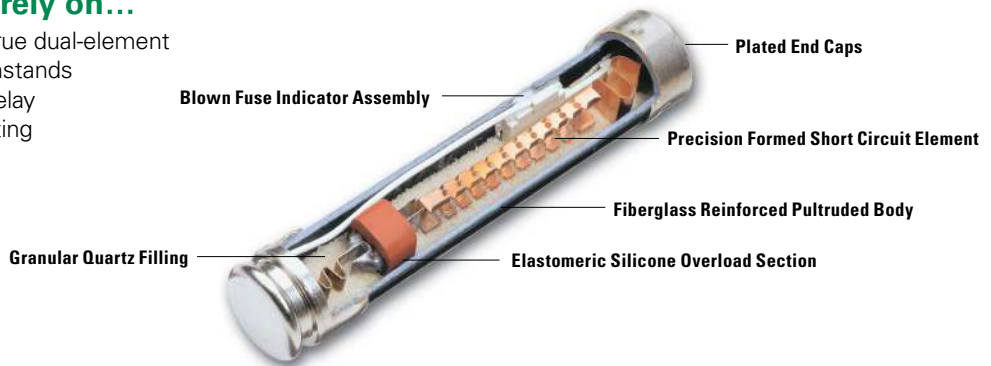

CLASS RK1 – KLNR / KLSR SERIES FUSES

250/600 Vac • Fast-Acting • 1-600 A



Description

KLSR and KLNR series are an economical design providing the safety of a RK1 fuse. The single element design provides fast-acting overload and short-circuit protection.

Use POWR-PRO® LLNRK and LLSRK series RK1, dual-element, time-delay fuses in all new applications requiring the current-limiting ability of UL Class RK1 fuses or in existing applications where fast-acting RK1 or RK5 fuses have been opening on harmless system surges such as motor starting currents.

Applications

- Resistance heaters
- Lighting circuits
- Non-inductive loads

Features/Benefits

- Extremely Current-Limiting
- Indicating and DIN mount fuse blocks available

Specifications

Voltage Ratings	AC: 600 Vac or less (KLSR) 250 Vac or less (KLNR) DC: 250 V (1 – 30 A KLSR); 300 V (35 – 600 A KLSR) 125 V (KLNR)
Ampere Range	1 – 600 A
Interrupting Ratings	AC: 200 kA rms symmetrical DC: 20 kA
Approvals	AC: Standard 248-12, Class RK1 UL Listed (File: E81895) CSA Certified (File: LR29862) DC: Littelfuse self-certified
Material	1-60 A: Composite body, Bronze cap (nickel plated) 70-100 A: Composite body, Copper caps 110-600 A: Melamine body, Copper caps
Country of Origin	Mexico

Ordering Information

AMPERE RATINGS				
1	10	40	100	250
2	12	45	110	300
3	15	50	125	350
4	20	60	150	400
5	25	70	175	450
6	30	80	200	500
8	35	90	225	600

VOLTAGE	SERIES	AMP	CATALOG NUMBER	ORDERING NUMBER
600	KLSR	90	KLSR090	KLSR090.V
250	KLNR	90	KLNR090	KLNR090.V

Web Resources

Download TC Curves, CAD drawings and other technical information: littelfuse.com/klsr
littelfuse.com/klnr

Recommended Fuse Blocks

LFR Series 94

Dimensions

Please refer to the Class R dimensions..... 19

Peak Let-Thru Curve (600 V)

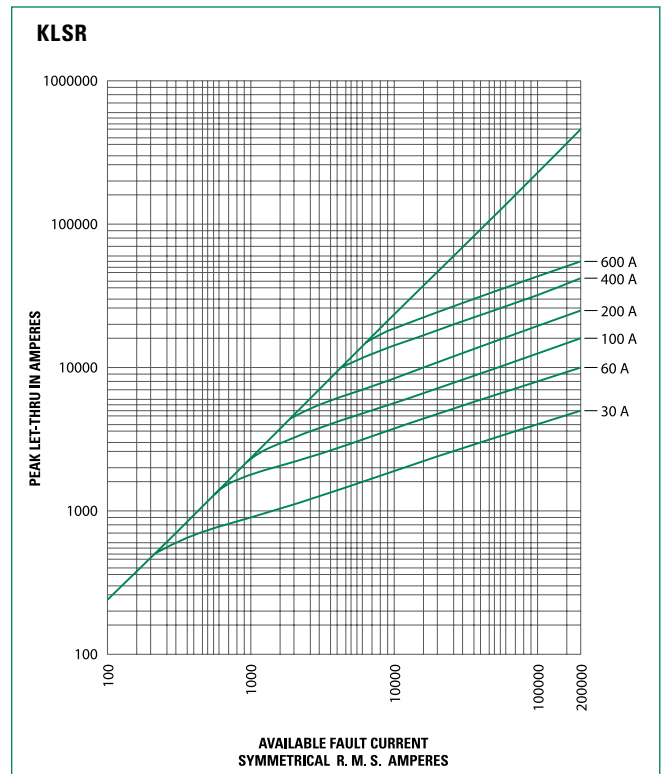

CLASS RK5 – IDSR SERIES INDICATOR® POWR-PRO® FUSES

POWR-PRO® 600 Vac/dc • Dual Element • Time-Delay • 1/10-600 A



1
UL Class RK5 Fuses



Description

The IDSR combines 600 Vdc capability with indication to provide an ideal solution for many DC applications.

Applications

- DC circuits
- Solar inverters
- Motors
- Transformers
- Solenoids
- Fluorescent lighting

Features/Benefits

- POWR-PRO® Performance
- Current limiting
- Indication

Specifications

Voltage Ratings

AC: 600 Vac or less
DC: 600 Vdc or less

Ampere Range

1/10 – 600 A

Interrupting Ratings

AC: 200 kA rms symmetrical
300 kA rms symmetrical
(Littelfuse self-certified)

DC: 20 kA

Approvals

Standard 248-12, Class RK5
UL Listed (File: E81895)

CSA Certified (File: LR29862)

Material

1/10-60 A: Composite body, Bronze caps
70-600 A: Composite body, Copper caps

Country of Origin

Mexico

Ordering Information

AMPERE RATINGS							
1/10	6/10	1 8/10	4	8	30	80	225
1/8	8/10	2	4 1/2	9	35	90	250
15/100	1	2 1/4	5	10	40	100	300
2/10	1 1/8	2 1/2	5 8/10	12	45	110	350
1/4	1 1/4	2 8/10	6	15	50	125	400
3/10	1 4/10	3	6 1/4	17 1/2	60	150	450
4/10	1 1/2	3 2/10	7	20	70	175	500
1/2	1 6/10	3 1/2	7 1/2	25	75	200	600

Note: All fuses rated 1A and above are Indicator® fuses.

VOLTAGE	SERIES	AMP	CATALOG NUMBER	ORDERING NUMBER
600	IDSR	30	IDSR030	IDSR030.T

Web Resources

Download TC Curves, CAD drawings and other technical information: littelfuse.com/idsr

Recommended Fuse Blocks

LFR Series 94

Dimensions

Please refer to the Class R dimensions..... 19

Peak Let-Thru Curve

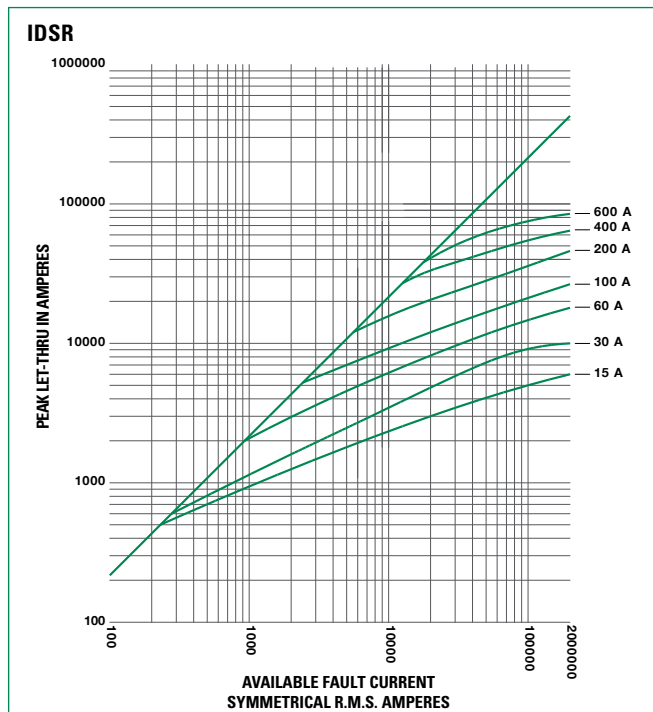

Note: For more information, see Peak Let-Thru Table on pg. 18

CLASS RK5 – FLNR_ID • FLRS_ID SERIES INDICATOR® FUSES

250/600 Vac • Dual Element • Time Delay • 1/10-600 A



Description

Available in both Indicating and Non-Indicating versions, the FLNR/FLSR series of fuses set the standard for general purpose fuses. The dual-element design provides advanced short circuit and overload protection. FLSR series fuses provide excellent protection for all types of circuits especially those containing motors.

Applications

- Service entrance switches
- Transformers
- Switchboard mains and feeders
- Motor control central mains and motor branch circuits
- All general purpose circuits

Features/Benefits

- Indication
- Dual-element design
- Available without indication
- Current limiting

Specifications

Voltage Ratings AC: 250 V (FLNR_ID); 600 V (FLSR_ID)
DC: 125 V (FLNR 1/10 – 30 A);
125 V (FLNR_ID 35 – 600 A);
300 V (FLSR_ID)

Interrupting Ratings AC: 200 kA rms symmetrical
300 kA rms symmetrical
(Littelfuse self-certified)
DC: 20 kA

Ampere Range 1/10 – 600 A

Approvals Standard 248-12, Class RK5
UL Listed (File: E81895)
CSA Certified (File: LR29862)
Federal Specification WF-1814
(QPL- W-F-1814)

Dimensions

Please refer to the Class R dimensions page 19.

Ordering Information

AMPERE RATINGS							
1/10	6/10	1 8/10	4	8	30	80	225
1/8*	8/10	2	4 1/2	9	35	90	250
15/100	1	2 1/4	5	10	40	100	300
2/10	1 1/8	2 1/2	5 8/10	12	45	110	350
1/4	1 1/4	2 8/10	6	15	50	125	400
3/10†	1 4/10	3	6 1/4	17 1/2	60	150	450
4/10	1 1/2	3 2/10	7	20	70	175	500
1/2	1 8/10	3 1/2	7 1/2	25	75**	200	600

*FLNR only. †FLNR, FLSR, FLSR_ID only. **FLNR, FLSR, FLSR_ID only
Note: For 1/10 – 30A 250 volt fuses, order non-indicating FLNR series fuses.

TYPE	VOLT	SERIES	AMP	CATALOG NUMBER	ORDERING NUMBER
NON-INDICATING	600	FLSR	15	FLSR015	FLSR015.T
INDICATING	600	FLSR_ID	15	FLSR015ID	FLSR015.TXID
NON-INDICATING	250	FLNR	60	FLNR060	FLNR060.T
INDICATING	250	FLNR_ID	60	FLNR060ID	FLNR060.TXID

Web Resources

Download TC Curves, CAD drawings and other technical information: littelfuse.com/flsr
littelfuse.com/flnr

Recommended Fuse Holders

LFR60 Series • LFR25 Series 94

Peak Let-Thru Curve (600 V)

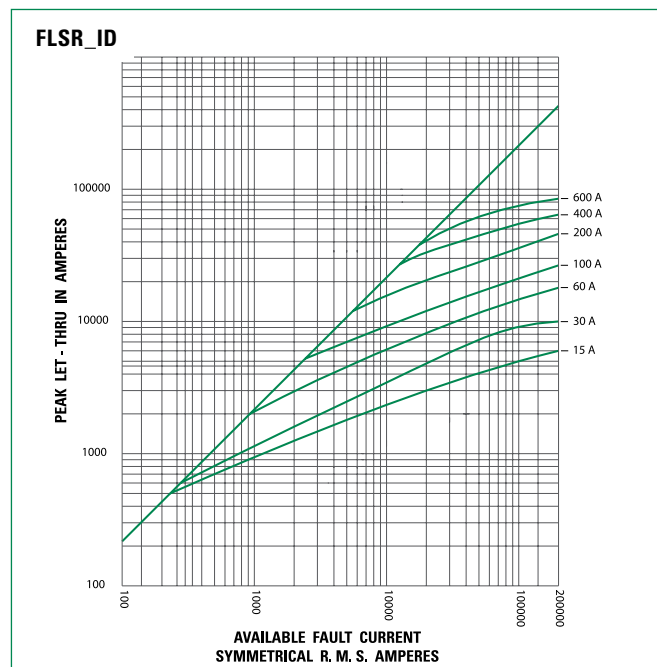

Note: For more information, see Peak Let-Thru Table on page 18.

CLASS RK5 CURRENT-LIMITING EFFECTS

 1
 UL Class RK5 Fuses

Current-Limiting Effects of IDSR (600 V) Fuses

SHORT CIRCUIT CURRENT*	APPARENT RMS SYMMETRICAL CURRENT FOR VARIOUS FUSE RATINGS						
	15 A	30 A	60 A	100 A	200 A	400 A	600 A
5,000	800	1,100	2,100	3,200	5,000	5,000	5,000
10,000	1,100	1,600	2,900	4,300	7,300	10,000	10,000
15,000	1,300	1,900	3,400	5,000	8,600	13,700	15,000
20,000	1,400	2,200	3,800	5,600	9,500	15,500	19,000
25,000	1,500	2,500	4,100	6,100	10,300	16,700	21,500
30,000	1,600	2,700	4,500	6,500	11,000	17,700	23,500
35,000	1,700	2,900	4,700	6,800	11,600	18,600	25,200
40,000	1,800	3,100	5,000	7,200	12,100	19,400	26,600
50,000	1,900	3,400	5,400	7,800	13,100	20,800	29,500
60,000	2,000	3,600	5,800	8,300	13,900	22,000	30,600
80,000	2,200	4,000	6,300	9,100	15,400	24,000	33,200
100,000	2,300	4,200	6,800	9,800	16,700	25,500	35,100
150,000	2,600	4,500	7,700	11,200	19,300	28,100	38,000
200,000	2,800	4,600	8,400	12,400	21,400	30,000	39,600

Current-Limiting Effects of FLNR and FLNR_ID (600 V) Fuses

SHORT-CIRCUIT CURRENT*	APPARENT RMS SYMMETRICAL CURRENT FOR VARIOUS FUSE RATINGS					
	30 A	60 A	100 A	200 A	400 A	600 A
5,000	1,250	2,100	3,200	5,000	5,000	5,000
10,000	1,600	2,850	4,300	7,250	10,000	10,000
15,000	1,800	3,400	5,000	8,500	13,500	15,000
20,000	2,250	3,800	5,500	9,500	15,750	19,000
25,000	2,450	4,100	5,700	10,250	17,000	21,000
30,000	2,700	4,500	6,400	10,750	18,000	23,000
35,000	2,900	4,800	6,700	11,500	19,000	24,250
40,000	3,000	5,000	7,250	12,000	19,500	27,000
50,000	3,400	5,250	7,750	13,000	21,000	29,000
60,000	3,600	5,750	8,100	14,000	22,000	30,500
80,000	3,900	6,250	9,000	15,000	24,000	33,000
100,000	4,300	6,750	9,750	16,500	26,000	35,000
150,000	4,500	7,600	11,100	19,000	28,000	38,000
200,000	4,600	8,400	12,250	21,500	30,000	40,000

Current-Limiting Effects of FLNR and FLNR_ID (250V) Fuses

SHORT-CIRCUIT CURRENT*	APPARENT RMS SYMMETRICAL CURRENT FOR VARIOUS FUSE RATINGS					
	30 A	60 A	100 A	200 A	400 A	600 A
5,000	1,400	2,100	3,100	5,000	5,000	5,000
10,000	1,550	2,500	3,900	6,500	9,500	10,000
15,000	2,000	3,150	4,400	7,250	10,500	14,000
20,000	2,250	3,400	5,000	8,250	12,000	16,000
25,000	2,400	3,750	5,250	9,000	12,500	16,500
30,000	2,550	4,100	5,600	9,500	13,500	18,000
35,000	2,650	4,300	5,800	9,750	14,000	19,000
40,000	2,800	4,400	6,250	10,250	15,000	20,000
50,000	3,000	5,000	6,500	10,500	16,000	21,000
60,000	3,200	5,250	7,000	11,500	17,000	23,000
80,000	3,400	5,750	7,500	12,500	19,000	25,500
100,000	3,850	6,000	8,000	13,500	21,000	27,500
150,000	4,100	7,000	9,000	15,200	24,000	31,500
200,000	4,300	7,500	9,750	16,500	26,000	34,000

*Prospective RMS Symmetrical Amperes Short-Circuit Current
 Note: Data Derived from Peak Let-Thru Curves

CLASS R SERIES DIMENSIONS

Dimensions

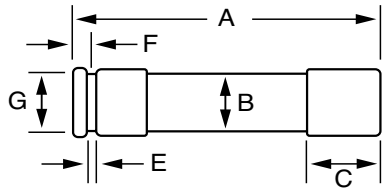

FIG. 1

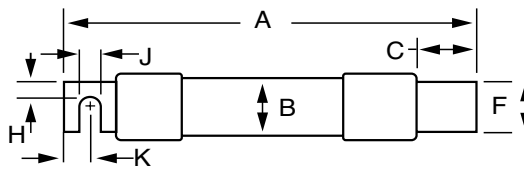
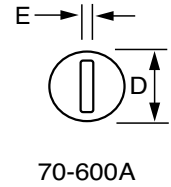

FIG. 2



70-600A

AMPS	FIGURE NUMBER	SERIES	DIMENSIONS INCHES (mm)									
			A	B	C	D	E	F	G	H	J	K
1/10-30	1	LLNRK KLNR FLNR	2 (50.8)	1/2 (12.7)	1/2 (12.7)	9/16 (14.3)	5/64 (2.0)	5/32 (4.0)	3/8 (9.5)	—	—	—
		LLSRK KLSR FLSR IDSR	5 (127.0)	3/4 (19.1)	5/8 (15.9)	13/16 (20.6)	3/32 (2.4)	3/16 (4.8)	5/8 (15.9)	—	—	—
35-60	1	LLNRK KLNR FLNR	3 (76.2)	3/4 (19.1)	5/8 (15.9)	13/16 (20.6)	3/32 (2.4)	3/16 (4.8)	5/8 (15.9)	—	—	—
		LLSRK KLSR FLSR IDSR	5 1/2 (139.7)	1 (25.4)	5/8 (15.9)	1 1/16 (27.0)	3/32 (2.4)	1/4 (6.4)	7/8 (22.2)	—	—	—
70-100	2	LLNRK KLNR FLNR	5 7/8 (149.2)	1 (25.4)	1 1/16 (27.0)	1 1/16 (27.0)	1/8 (3.2)	3/4 (19.1)	—	1/4 (6.4)	9/32 (7.1)	1/2 (12.7)
		LLSRK KLSR FLSR IDSR	7 7/8 (200.0)	1 1/4 (31.8)	1 1/16 (27.0)	1 5/16 (33.3)	1/8 (3.2)	3/4 (19.1)	—	1/4 (6.4)	9/32 (7.1)	1/2 (12.7)
110-200	2	LLNRK KLNR FLNR	7 7/8 (181.0)	1 1/2 (38.1)	1 15/32 (37.3)	1 19/32 (40.5)	3/16 (4.8)	1 1/8 (28.6)	—	7/16 (11.1)	9/32 (7.1)	1 1/16 (17.5)
		LLSRK KLSR FLSR IDSR	9 5/8 (244.5)	1 3/4 (44.5)	1 15/32 (37.3)	1 27/32 (46.8)	3/16 (4.8)	1 1/8 (28.6)	—	7/16 (11.1)	9/32 (7.1)	1 1/16 (17.5)
225-400	2	LLNRK KLNR FLNR	8 5/8 (219.1)	2 (50.8)	1 15/16 (49.2)	2 3/32 (53.2)	1/4 (6.4)	1 5/8 (41.3)	—	5/8 (15.9)	1 3/32 (10.3)	1 5/16 (23.8)
		LLSRK KLSR FLSR IDSR	11 15/8 (295.3)	2 1/2 (63.5)	2 (50.8)	2 19/32 (65.9)	1/4 (6.4)	1 5/8 (41.3)	—	5/8 (15.9)	1 3/32 (10.3)	1 5/16 (23.8)
450-600	2	LLNRK KLNR FLNR	10 3/8 (263.5)	2 1/2 (63.5)	2 3/8 (60.3)	2 19/32 (65.9)	1/4 (6.4)	2 (50.8)	—	3/4 (19.1)	1 7/32 (13.5)	1 1/8 (28.6)
		LLSRK KLSR FLSR IDSR	13 3/8 (339.7)	3 (76.2)	2 13/32 (61.1)	3 3/32 (78.6)	1/4 (6.4)	2 (50.8)	—	3/4 (19.1)	1 7/32 (13.5)	1 1/8 (28.6)

CLASS K5 - NLN / NLS SERIES (ONE-TIME) FUSES

250/600 Vac • “One-Time” • 1-600 A



1
UL Class K5 Fuses

Description

NLN and NLS fuses provide low cost protection for general purpose feeder and branch circuits when available short circuit currents are less than 50 kA.

Note: Canadian Electrical Code NLKP Type P fuse available. Visit littelfuse.com/nlkp

Applications

General purpose residential and commercial circuits with little or no motor load.

Features/Benefits

- Economical
- 50 kA interrupting rating
- Indicating and DIN mount holders available

Web Resources

Download TC Curves, CAD drawings and other technical information: littelfuse.com/nln
littelfuse.com/nls

Dimensions

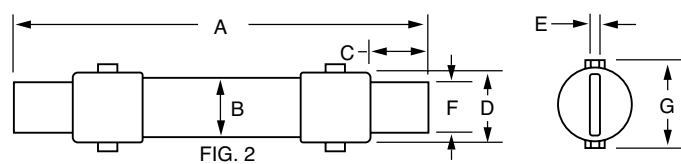
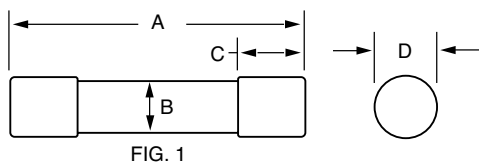

AMPERES	REFER TO FIG. NO.	SERIES	DIMENSIONS INCHES (mm)						
			A	B	C	D	E	F	G
1 – 30	1	NLN	2 (50.8)	½ (12.7)	½ (12.7)	9/16 (14.3)	—	—	—
		NLS	5 (127.0)	¾ (19.1)	5/8 (15.9)	13/16 (20.6)	—	—	—
35 – 60	1	NLN	3 (76.2)	¾ (19.1)	5/8 (15.9)	13/16 (20.6)	—	—	—
		NLS	5½ (139.7)	1 (25.4)	5/8 (15.9)	1½ (38.1)	—	—	—
70 – 100	2	NLN	5½ (149.2)	1 (25.4)	1 (25.4)	1½ (38.1)	1/8 (3.2)	¾ (19.1)	1½ (38.1)
		NLS	7½ (200.0)	1¼ (31.8)	1 (25.4)	1¾ (44.5)	1/8 (3.2)	¾ (19.1)	1¾ (44.5)
110 – 200	2	NLN	7½ (181.0)	1½ (38.1)	1½ (38.1)	1¾ (44.5)	3/16 (4.8)	1½ (38.1)	1¾ (44.5)
		NLS	9½ (244.5)	1¾ (44.5)	1½ (38.1)	2 (50.8)	3/16 (4.8)	1½ (38.1)	2 (50.8)
225 – 400	2	NLN	8½ (219.1)	2 (50.8)	1¾ (47.6)	2 (50.8)	¼ (6.4)	1½ (38.1)	2 (50.8)
		NLS	11½ (295.3)	2½ (63.5)	1¾ (47.6)	2½ (63.5)	¼ (6.4)	1½ (38.1)	2½ (63.5)
450 – 600	2	NLN	10¾ (263.5)	2½ (63.5)	2¼ (57.2)	2½ (63.5)	¼ (6.4)	2 (50.8)	2½ (63.5)
		NLS	13¾ (339.7)	3 (76.2)	2¼ (57.2)	3 (76.2)	¼ (6.4)	2 (50.8)	3 (76.2)

Specifications

Voltage Ratings

AC: 600 Vac or less (NLS)
250 Vac or less (NLN)
DC: 400 V (NLS 35 – 60 A)
500 V (NLS 8 – 30 A) (NLS 225 – 600 A)
600 V (NLS 1 – 7 A) (NLS 70 – 200 A)
250 V (NLN)

Ampere Range

1 – 600 A

Interrupting Ratings

AC: 50 kA rms symmetrical
DC: 20 kA (1 – 60 A)
50 kA (70 – 600 A)

Approvals

Standard 248-9, Class K5
UL Listed (File: E81895)

Material

CSA Certified (File: LR29862)
NLS: 1-15 A: Fiber body, Bronze cap
20-60 A: Composite body, Bronze cap
70-600 A: Fiber body, Copper cap (tin plated)
NLN: 1-30 A: Ceramic body
35-60 A: Fiber body, Bronze cap
70-600 A: Fiber body, Copper cap (tin plated)

Country of Origin

Mexico

Ordering Information

AMPERE RATINGS					
1	7	*25	*60	125	300
2	8	*30	70	150	350
3	10	*35	80	175	400
4	12	*40	90	200	450
5	*15	*45	100	225	500
6	*20	*50	110	250	600

*NLKP series available only in those amperages preceded by an asterisk.

VOLTAGE	SERIES	AMP	CATALOG NUMBER	ORDERING NUMBER
600	NLS	20	NLS020	0NLS020.T
250	NLN	15	NLN015	0NLN015.T

Recommended Fuse Blocks

LFH Series 94

CLASS J - JTD SERIES INDICATOR® POWR-PRO® FUSES

POWR-PRO® 600 Vac • Time Delay • 8/10-600 A



Description

The Littelfuse POWR-PRO® JTD_ID Indicator Class J fuse provides visual blown fuse indication and maximum protection in a compact package. The current-limiting time delay JTD_ID offers a patented design which reduces nuisance fuse openings.

Features/Benefits

- POWR-PRO® Performance
- Current-Limiting
- IEC Type 2 Protection
- Indication and non-indication version available
- Indicating and DIN mount holders available

Applications

- Fused combination motor controllers and motor control centers
- Transformer protection
- Protection for series rated molded case circuit-breaker panels
- General purpose circuits

Web Resources

Download TC Curves, CAD drawings and other technical information: littelfuse.com/jtd

Recommended Fuse Holders

- LFJ60 Series 91
- LFPSJ Series (8/10-60 A)..... 118

Dimensions

Please refer to the Class J dimensions 23

Specifications

Voltage Ratings	AC: 600 V DC: 300 V (8/10-100 A) 500 V (110-600 A)
Amperage Range	8/10-600 A
Interrupting Rating	AC: 200 kA rms symmetrical 300kA rms symmetrical (Littelfuse self-certified) DC: 20 kA
Material	Body: Melamine Caps: Nickel-plated Bronze (8/10-60 A) Brass (70-200 A) Brass Cap with Copper Blade (225-600 A)
Approvals	AC: Standard 248-8, Class J UL Listed (File: E81895) CSA Certified (File: LR29862) DC: Littelfuse self-certified
Country of Origin	Mexico

Ordering Information

AMPERAGE RATINGS							
8/10	2¼	4½	10	35	90	225	600
1	2½	5	12	40	100	250	—
1¼	2¾	5½	15	45	110	300	—
1½	3	6	17½	50	125	350	—
1¾	3¼	7	20	60	150	400	—
1⅞	3½	8	25	70	175	450	—
2	4	9	30	80	200	500	—

TYPE	SERIES	AMPERAGE	CATALOG NUMBER	ORDERING NUMBER
INDICATING	JTD_ID	60	JTD60ID	OJTD060.TXID
NON-INDICATING	JTD	60	JTD60	OJTD060.T

Peak Let-Thru Curve

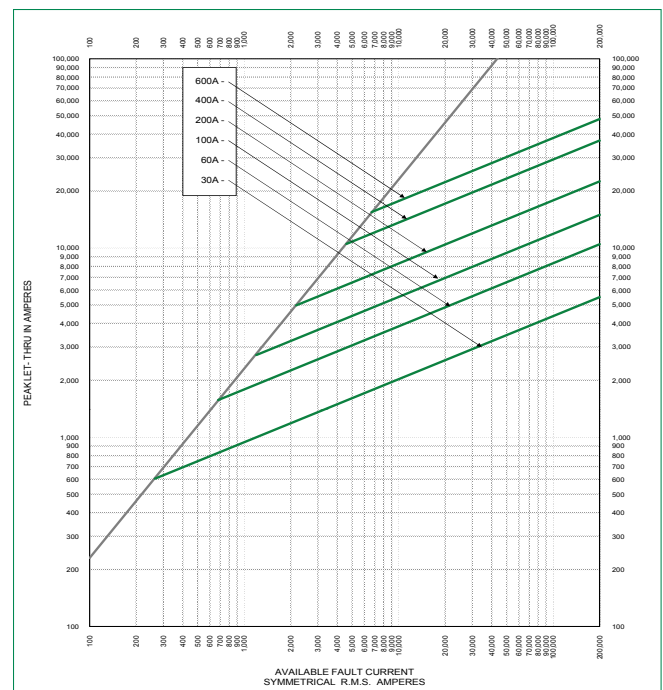

Note: For more information, see Peak Let-Thru Table on page 23.

CLASS J – JLS SERIES FUSES

600 VAC • Fast-Acting • 1-600 A



1

UL Class J Fuses



Description

The UL Listed Class J JLS Series fuses provide space saving, fast-acting overload and short-circuit protection for vital industrial and power conversion applications. Littelfuse's JLS Series fuses offer best in class current limitation that prevents equipment damage from overcurrent faults.

Features and Benefits

- Superior performance in a space saving package
- Reliable interruption of all overcurrents with protection up to 200kA
- Extremely current limiting
- Fast-acting protection for surge-sensitive devices and components
- Reduces heating and magnetic effects due to overcurrents, extending equipment life
- Economical and readily available

Applications

- Power conversion device protection
- Variable speed drives
- Rectifiers
- Resistive loads
- Solid-state devices

Web Resources

Download TC curves, CAD drawings and other technical information: littelfuse.com/jls

Recommended Fuse Holders

LFJ60 Series	91
LFPSJ Series (3/10-60 A).....	118

Specifications

Voltage Ratings	600 VAC
Interrupting Ratings	200 kA rms symmetrical
Ampere Range	1-600 A
Approvals	Standard 248-8, Class J UL Listed (File: E81895) CSA Certified (File: LR29862) Federal Specification WF-1814 (QPL-W-F-1814)

Ordering Information

AMPERE RATINGS					
1	20	45	90	175	350
3	25	50	100	200	400
6	30	60	110	225	450
10	35	70	125	250	500
15	40	80	150	300	600

TYPE	SERIES	AMPERAGE	CATALOG NUMBER	ORDERING NUMBER
NON-INDICATING	JLS	110	JLS110	0JLS110.X

Peak Let-Thru Curve

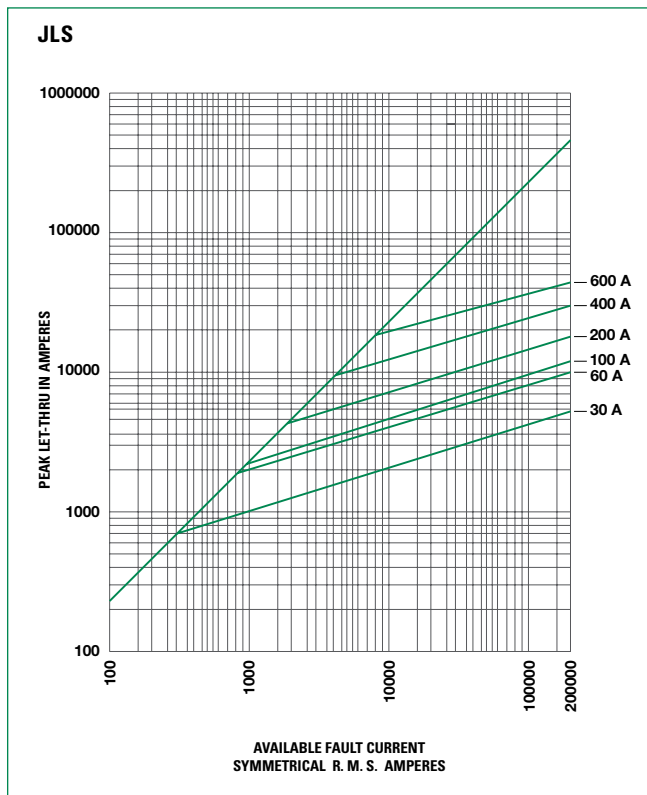

Dimensions

Please refer to the Class J dimensions 23

CLASS J DIMENSIONS AND CURRENT-LIMITING EFFECTS

Dimensions Inches (mm)

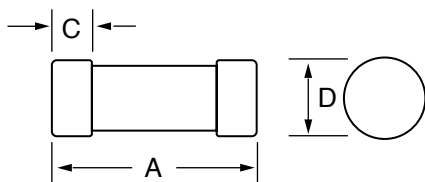

Fig. 1

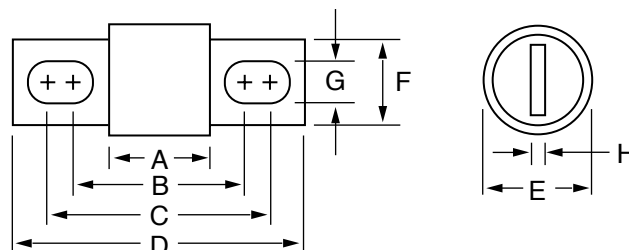

Fig. 2

Dimensions of JTD_ID, JTD and JLS

AMPERES	FIGURE NUMBER	DIMENSIONS INCHES (mm)							
		A	B	C	D	E	F	G	H
1 – 30	1	2¼ (57.2)	—	½ (12.7)	1³⁄₁₆ (20.6)	—	—	—	—
35 – 60	1	2³⁄₈ (60.3)	—	⁵⁄₈ (15.9)	1¼ (27.0)	—	—	—	—
70 – 100	2	2⁵⁄₈ (66.7)	3¹⁷⁄₃₂ (89.7)	3²³⁄₃₂ (94.5)	4⁵⁄₈ (117.5)	1½ (28.6)*	¾ (19.1)	⁹⁄₃₂ (7.1)	⅙ (3.2)
110 – 200	2	3 (76.2)	4⁹⁄₃₂ (108.7)	4¹⁵⁄₃₂ (113.5)	5¾ (146.1)	1½ (38.1)	1½ (28.6)	⁹⁄₃₂ (7.1)	⅜ (4.8)
225 – 400	2	3¾ (85.7)	5⅞ (130.2)	5¾ (136.5)	7⅞ (181.0)	2 (50.8)	1⅝ (41.3)	1³⁄₃₂ (10.3)	¼ (6.4)
450 – 600	2	3¾ (95.3)	5²⁷⁄₃₂ (148.4)	6⁵⁄₃₂ (156.4)	8 (203.2)	2½ (63.5)	2 (50.8)	1⁷⁄₃₂ (13.5)	⅜ (9.5)

*70-100 A JLS dimension = 1 (25.4)

Current-Limiting Effects of JTD_ID (600 V) Fuses

SHORT CIRCUIT CURRENT†	APPARENT RMS SYMMETRICAL CURRENT FOR VARIOUS FUSE RATINGS						
	15 A	30 A	60 A	100 A	200 A	400 A	600 A
5,000	565	750	1,500	1,800	2,800	4,800	5,000
10,000	675	925	1,900	2,450	3,600	5,700	7,750
15,000	775	1,050	2,100	2,800	4,100	6,500	9,000
20,000	825	1,125	2,300	3,000	4,400	7,250	9,700
25,000	900	1,200	2,500	3,300	5,000	8,000	10,500
30,000	950	1,300	2,600	3,500	5,100	8,400	11,000
35,000	1,000	1,350	2,700	3,700	5,400	9,000	12,000
40,000	1,050	1,400	2,800	3,900	5,600	9,200	12,500
50,000	1,100	1,500	3,000	4,200	6,000	10,000	13,000
60,000	1,200	1,600	3,200	4,500	6,400	10,500	14,000
80,000	1,300	1,700	3,400	4,900	7,200	11,200	15,500
100,000	1,375	1,800	3,600	5,200	7,800	12,200	16,500
150,000	1,500	2,000	3,950	6,000	9,000	14,500	19,000
200,000	1,600	2,175	4,000	6,500	10,000	16,000	20,500

†Prospective RMS Symmetrical Amperes Short-Circuit Current
Note: Data derived from Peak Let-Thru Curves

CLASS T - JLLN / JLLS SERIES FUSES

300/600 Vac • Fast-Acting • 1-1200 A



1
UL Class T Fuses

Description

JLLN / JLLS fuses are less than 1/3 the size of comparable Class R fuses and are typically used for short circuit protection of drives and surge sensitive components. When rated in accordance with the NEC®, JLLN / JLLS fuses provide fast-acting overload and short circuit protection for non-inductive circuits and equipment.

Features/Benefits

- Extremely current-limiting
- Compact design
- 200 kA Interrupting Rating
- JLLN 35-60 A available with PCB mounts (see datasheet)

Applications

- Variable speed drive protection
- Compact mains switches

Specifications

Voltage Ratings

AC: 300 V (JLLN)
600 V (JLLS)
DC: 125 V (JLLN 70 – 1200 A)
160 V (JLLN 1 – 60 A)
300 V (JLLS)

Interrupting Ratings

AC: 200 kA rms symmetrical
DC: 20 kA (JLLN 35-1200 A only)
1 – 1200 A

Ampere Range

Approvals

AC: Standard 248-15, Class T
UL Listed (File: E81895):
JLLN (1 – 1200 A)
JLLS (1 – 1200 A)
CSA Certified (File: LR29862)
JLLN/JLLS (1 – 600 A)
DC: UL Listed (File: E81895):
JLLN (35 – 1200 A)
Littelfuse self-certified
JLLN (1 – 30 A)
JLLS (1 – 1200 A)

Material

JLLN: 1-30 A: Melamine body, Bronze caps
35-1200 A: Melamine body, Copper caps
JLLS: 1-30 A: Melamine body, Copper caps
35-60 A: Melamine body, Bronze caps
70-1200 A: Melamine body, Copper caps

Environmental

RoHS Compliant

Ordering Information

AMPERE RATINGS					
1	25	70	175	450	1100
2	30	80	200	500	1200
3	35	90	225	600	
6	40	100	250	700	
10	45	110	300	800	
15	50	125	350	900*	
20	60	150	400	1000	

*JLLS only

Part Numbering System

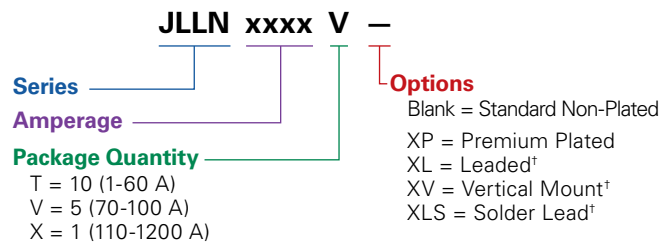

SERIES	AMP	PACK SIZE	PLATING SUFFIX	MOUNT SUFFIX	CATALOG NUMBER	ORDERING NUMBER
JLLS	6	T	–	–	JLLS006	JLLS006.T
JLLN	35	V	–	XL†	JLLN035L	JLLN035.VXL
JLLN	100	V	XP	–	JLLN100P	JLLN100.VXP

†Option is available for JLLN 35-60 A only. Premium plating is standard

Web Resources

Download TC Curves, CAD drawings and other technical information: littelfuse.com/jlln
littelfuse.com/jlls

Recommended Fuse Holders

LFT30 Series.....	100
LFT60 Series.....	100
LSCR Series for 70-800 A.....	127

Dimensions

Please refer to the Class T dimensions..... 25
Please refer to the JLLN datasheet for PCB mount dimensions: littelfuse.com/jlln

CLASS T DIMENSIONS AND CURRENT-LIMITING EFFECTS

Dimensions Inches (mm)

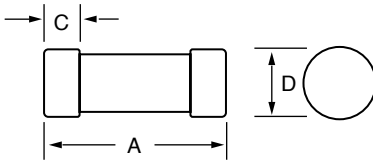

Fig. 1

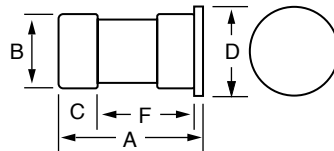

Fig. 2

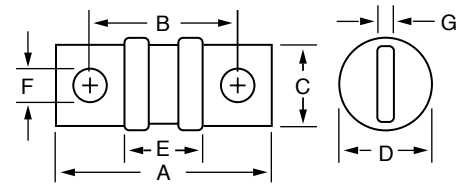

Fig. 3

AMPERES	REFER TO FIG. NO.	SERIES	DIMENSIONS INCHES (mm)						
			A	B	C	D	E	F	G
1 – 30	1	JLLN	.875 (22.2)	—	.281 (7.1)	.406 (10.3)	—	—	—
		JLLS	1.500 (38.1)	—	.281 (7.1)	.562 (14.3)	—	—	—
35 – 60	1	JLLN	.875 (22.2)	—	.281 (7.1)	.562 (14.3)	—	—	—
		JLLS	1.562 (39.7)	.812 (20.6)	.406 (10.3)	.994 (25.2)	.062 (1.6)	1.094 (27.8)	—
70 – 100	3	JLLN	2.156 (54.8)	1.562 (39.7)	.750 (19.1)	.812 (20.6)	.830 (21.1)	.281 (7.1)	.125 (3.2)
		JLLS	2.953 (75.0)	2.352 (59.7)	.750 (19.1)	.828 (21.0)	1.625 (41.3)	.281 (7.1)	.125 (3.2)
110 – 200	3	JLLN	2.437 (61.9)	1.687 (42.9)	.875 (22.2)	1.062 (27.0)	.830 (21.1)	.343 (8.7)	.187 (4.8)
		JLLS	3.250 (82.6)	2.507 (63.7)	.875 (22.2)	1.078 (27.4)	1.656 (42.1)	.343 (8.7)	.187 (4.8)
225 – 400	3	JLLN	2.750 (69.9)	1.843 (46.8)	1.000 (25.4)	1.312 (33.3)	.828 (21.0)	.406 (10.3)	.250 (6.4)
		JLLS	3.625 (92.1)	2.718 (69.1)	1.000 (25.4)	1.593 (40.5)	1.712 (43.5)	.406 (10.3)	.250 (6.4)
450 – 600	3	JLLN	3.062 (77.8)	2.031 (51.6)	1.250 (31.8)	1.593 (40.5)	.875 (22.2)	.484 (12.3)	.312 (7.9)
		JLLS	3.984 (101.2)	2.953 (75.0)	1.250 (31.8)	2.062 (52.4)	1.765 (44.8)	.484 (12.3)	.312 (7.9)
700 – 800	3	JLLN	3.375 (85.7)	2.218 (56.4)	1.750 (44.5)	2.062 (52.4)	.875 (22.2)	.546 (13.9)	.375 (9.5)
		JLLS	4.328 (109.9)	3.171 (80.6)	1.750 (44.5)	2.500 (63.5)	1.860 (47.2)	.546 (13.9)	.375 (9.5)
900 – 1200	3	JLLN	4.000 (101.6)	2.531 (64.3)	2.000 (50.8)	2.500 (63.5)	1.033 (26.2)	.609 (15.5)	.437 (11.1)
		JLLS	5.271 (133.9)	3.801 (96.5)	2.000 (50.8)	2.625 (66.7)	2.303 (58.5)	.609 (15.5)	.437 (11.1)

Current-Limiting Effects of JLLN (300 V) fuses

SHORT CIRCUIT CURRENT*	APPARENT RMS SYMMETRICAL CURRENT FOR VARIOUS FUSE RATINGS							
	30 A	60 A	100 A	200 A	400 A	600 A	800 A	1200 A
5,000	700	775	1,100	1,650	3,500	4,000	5,000	5,000
10,000	900	1,000	1,400	2,100	4,400	5,100	6,750	8,250
15,000	1,000	1,100	1,600	2,400	5,000	5,900	7,750	10,000
20,000	1,100	1,250	1,800	2,700	5,500	6,500	8,750	11,000
25,000	1,230	1,300	1,950	2,900	6,000	7,000	9,500	12,000
30,000	1,300	1,475	2,050	3,100	6,400	7,500	10,000	12,500
35,000	1,330	1,575	2,150	3,300	6,750	7,750	10,500	13,500
40,000	1,430	1,600	2,300	3,500	7,000	8,000	11,000	14,000
50,000	1,500	1,750	2,400	3,700	7,500	8,750	12,000	15,000
60,000	1,700	1,900	2,700	4,000	8,000	9,500	12,500	16,000
80,000	1,850	2,100	2,800	4,400	9,000	10,500	14,000	17,500
100,000	2,000	2,250	3,150	4,800	9,750	11,500	15,000	18,500
150,000	2,300	2,600	3,600	5,500	11,000	13,000	17,500	22,000
200,000	2,600	2,800	3,900	6,000	12,000	14,500	19,500	24,000

*Prospective RMS Symmetrical Amperes Short-Circuit Current
Note: Data Derived from Peak Let-Thru Curves

Current-Limiting Effects of JLLS (600 V) fuses

SHORT CIRCUIT CURRENT*	APPARENT RMS SYMMETRICAL CURRENT FOR VARIOUS FUSE RATINGS							
	30 A	60 A	100 A	200 A	400 A	600 A	800 A	1200 A
5,000	750	1,225	1,810	2,500	4,600	5,000	5,000	5,000
10,000	945	1,525	2,300	3,150	6,000	8,500	9,400	10,000
15,000	1,050	1,700	2,610	3,600	6,600	9,750	10,500	13,000
20,000	1,150	1,900	2,900	3,950	7,250	10,500	11,000	14,750
25,000	1,300	2,050	3,100	4,250	8,000	11,500	12,500	15,500
30,000	1,375	2,150	3,300	4,500	8,250	12,000	13,750	16,500
35,000	1,400	2,250	3,500	4,750	8,500	13,000	14,000	17,000
40,000	1,425	2,400	3,650	4,950	8,700	14,000	14,750	18,000
50,000	1,600	2,450	3,900	5,350	9,500	14,500	16,000	20,000
60,000	1,650	2,625	4,150	5,650	10,000	15,500	17,300	21,000
80,000	1,825	2,800	4,570	6,250	11,000	17,000	18,750	23,000
100,000	2,000	3,100	4,950	6,700	12,000	18,000	20,000	25,000
150,000	2,250	3,400	5,650	7,700	13,000	21,000	23,000	28,500
200,000	2,450	3,800	6,200	8,450	15,000	23,000	25,000	31,000

*Prospective RMS Symmetrical Amperes Short-Circuit Current
Note: Data Derived from Peak Let-Thru Curves

CLASS G - SLC CLASS G FUSES

480/600 VAC • Time-Delay • 1/2-60 A



1
UL Class G Fuses

Specifications

Voltage Ratings	600 VAC (1/2 – 20 A) 480 VAC (25 – 60 A) 170 VDC (1/2 – 60 A) (Littelfuse self-certified)
Interrupting Ratings	AC: 100 kA rms symmetrical DC: 10 kA
Ampere Range	1/2 – 60 A
Approvals	Standard 248-5, Class G UL Listed (File: E81895) CSA Certified (File: LR29862) Federal Specification WF-1814 (QPL-W-F-1814)
Environmental	RoHS Compliant

Description

Littelfuse SLC fuses provide cost effective branch circuit protection. Fuse length varies to prevent over-fusing. Compact Class G fuses were the first fuse series to approach midget fuse dimensions and meet NEC® requirements for branch-circuit protection.

Features/Benefits

- Branch circuit rated
- Current-limiting
- 100 kA interrupting rating
- 600 VAC rated 1/2-20 A

Applications

- Branch circuit protection

Web Resources

Download TC Curves, CAD drawings and other technical information: littelfuse.com/slc

Recommended Fuse Holders

LFG60 Series (1-20 A).....	105
LFG48 Series (25-60 A).....	105

Ordering Information

Part Numbering System

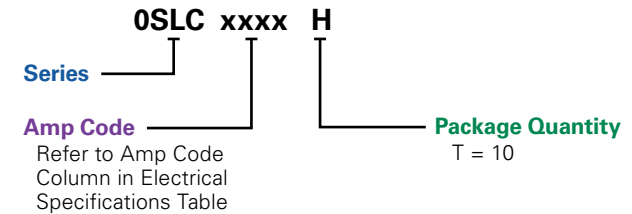

SERIES	AMP	PACKAGE QUANTITY	CATALOG NUMBER	ORDERING NUMBER
SLC	2	10	SLC002	OSLC002.T

Dimensions

Ferrule Version

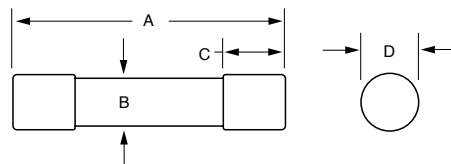

AMP	DIMENSIONS INCHES (mm)			
	A	B	C	D
1/2 – 15	1 5/16 (33.3)	3/8 (9.5)	9/32 (7.1)	13/32 (10.3)
20	1 13/32 (35.7)	3/8 (9.5)	9/32 (7.1)	13/32 (10.3)
25, 30	1 5/8 (41.3)	3/8 (9.5)	9/32 (7.1)	13/32 (10.3)
35 – 60	2 1/4 (57.2)	3/8 (9.5)	1/2 (12.7)	13/32 (10.3)

CLASS CC/CD - CCMR SERIES POWR-PRO® FUSES

POWR-PRO® 600 Vac • Dual Element • Time-Delay • 2/10-60 A



Description

The CCMR series is ideal for space saving protection of motors up to 40 hp*. It was designed specifically to withstand sustained starting currents of small motors. The CCMR 60 fuse is the smallest 60 A fuse available rated at 600 V. Compared to other UL Listed fuses, Class CC fuses are the most current-limiting, rating for rating.

Features/Benefits

- POWR-PRO® Performance
- Extremely current-limiting
- Ratings up to 60 Amps
- 300 kA Interrupting Rating (self-certified)

Applications

- Motor and motor branch circuit protection

Specifications

Voltage Rating

AC: 600 Vac or less
 DC: 250 V (CCMR 2/10–2 A)
 (CCMR 4 1/2–10 A)
 (CCMR 35–60 A)
 300 V (CCMR 2 1/4–4 A)
 500 V (CCMR 12–30 A)

Ampere Rating

2/10 – 60 A

Interrupting Rating

AC: 200 kA rms symmetrical
 300 kA Littelfuse self-certified
 DC: 20 kA

Approvals

AC: Standard 248-4, Class CC
 UL Listed 2/10-30 A (File: E81895)
 Standard 248, Class CD
 UL Listed 35-60 A (File: E81895)
 CSA Certified (File: LR29862)

Material

DC: Littelfuse self-certified
 2/10-30 A: Melamine body,
 Bronze cap (nickel plated)

Environmental

RoHS Compliant (except 35-60 A)

Country of Origin

Mexico

*Consult Motor Protection Tables on page 208 in the Technical Application Guide section for specific motor sizing information.

Ordering Information

AMPERE RATINGS						
2/10	1	2	3 1/2	6 1/4	12	35
1/4	1 1/4	2 1/4	4	7	15	40
3/10	1 4/10	2 1/2	4 1/2	7 1/2	17 1/2	45
1/2	1 1/2	2 8/10	5	8	20	50
6/10	1 6/10	3	5 6/10	9	25	60
8/10	1 8/10	3 2/10	6	10	30	

SERIES	AMP	ROHS	CATALOG NUMBER	ORDERING NUMBER
CCMR	10	•	CCMR010	CCMR010.TXP
CCMR	45		CCMR045	CCMR045.T

Web Resources

Download TC Curves, CAD drawings and other technical information: littelfuse.com/ccmr

Recommended Fuse Holders

LFC600 Series	107
L60030C Series	107
LPSC Touch-Safe Series	117

Dimensions

Please refer to the Class CC/CD dimensions 29

Peak Let-Thru Curve

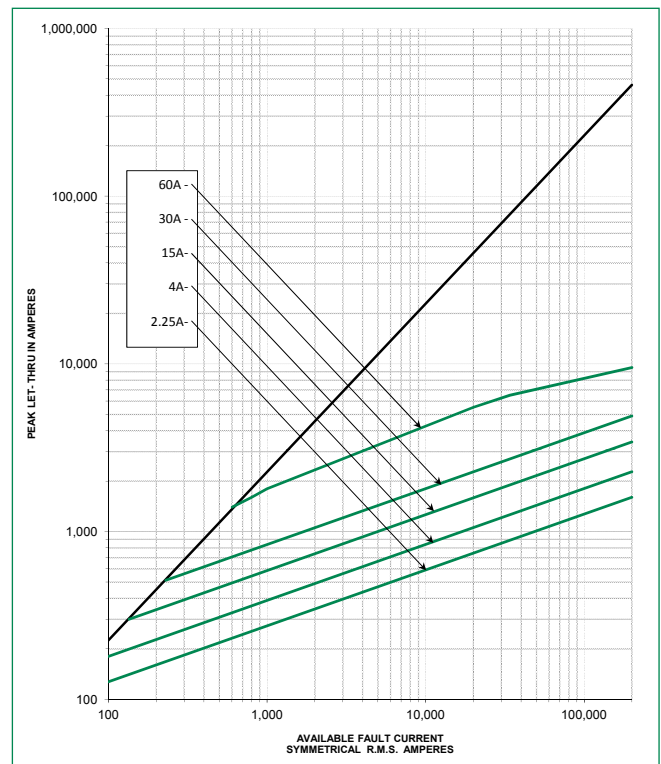

Note: For more information, see Peak Let-Thru Table on pg. 29

CLASS CC - KLDR / KLKR SERIES FUSES



1
UL Class CC Fuses

KLDR Series
600 Vac/300 Vdc • Time-Delay • 1/10-30 A



Description

KLDR fuses are time-delay fuses designed to protect control transformers, solenoids and similar inductive components with high magnetizing currents during the first half-cycle. They provide excellent protection of motor branch circuits containing IEC or NEMA rated motor controllers or contactors.

Specifications

Voltage Rating	AC: 600 Vac or less DC: 300 Vdc
Ampere Range	1/10 – 30 A
Interrupting Rating	AC: 200 kA rms symmetrical DC: 20 kA
Approvals	AC: Standard 248-4, Class CC UL Listed 1/10-30 A (File: E81895) CSA Certified 1/10-30 A (File: LR29862) DC: Littelfuse self-certified
Material	Melamine body Bronze caps (nickel plated)
Environmental	RoHS Compliant
Country of Origin	Mexico

Ordering Information

AMPERE RATINGS				
1/10	6/10	1 8/10	4 1/2	10
1/8	3/4	2	5	12
15/100	8/10	2 1/4	5 6/10	15
3/16	1	2 1/2	6	17 1/2
2/10	1 1/8	2 8/10	6 1/4	20
1/4	1 1/4	3	7	25
3/10	1 4/10	3 2/10	7 1/2	30
4/10	1 1/2	3 1/2	8	—
1/2	1 6/10	4	9	—

SERIES	AMP	CATALOG NUMBER	ORDERING NUMBER
KLDR	10	KLDR010	KLDR010.TXP

Web Resources

For additional information, visit:
littelfuse.com/klkr

Recommended Fuse Holders

L60030C Series	107
LPSC Touch-Safe Series	117

Dimensions

Please refer to the Class CC dimensions..... 29

KLKR Series
600 Vac/300 Vdc • Fast-Acting • 1/10-30 A



Description

KLKR Series Class CC fuses are fast-acting fuses intended for general purpose branch circuit protection. Their compact size, fast-acting overload response, and highly current-limiting design make them ideal for use in OEM equipment and control panels.

Specifications

Voltage Rating	AC: 600 Vac or less DC: 300 Vdc
Ampere Range	1/10 – 30 A
Interrupting Rating	AC: 200 kA rms symmetrical DC: 20 kA
Approvals	AC: Standard 248-4, Class CC UL Listed 1/10-30 A (File: E81895) CSA Certified 1/10-30 A (File: LR29862) DC: Littelfuse self-certified
Material	Melamine body Bronze caps (nickel plated)
Environmental	RoHS Compliant
Country of Origin	Mexico

Ordering Information

AMPERE RATINGS				
1/10	1/2	2 1/2	6	12
1/8	3/4	3	7	15
2/10	1	3 1/2	8	20
1/4	1 1/2	4	9	25
3/10	2	5	10	30

SERIES	AMP	CATALOG NUMBER	ORDERING NUMBER
KLKR	12	KLKR012	KLKR012.T

Web Resources

For additional information, visit:
littelfuse.com/klkr

Recommended Fuse Holders

L60030C Series	107
LPSC Touch-Safe Series	117

Dimensions

Please refer to the Class CC dimensions..... 29

CLASS CC / CD DIMENSIONS AND CURRENT-LIMITING EFFECTS

Dimensions Inches (mm)

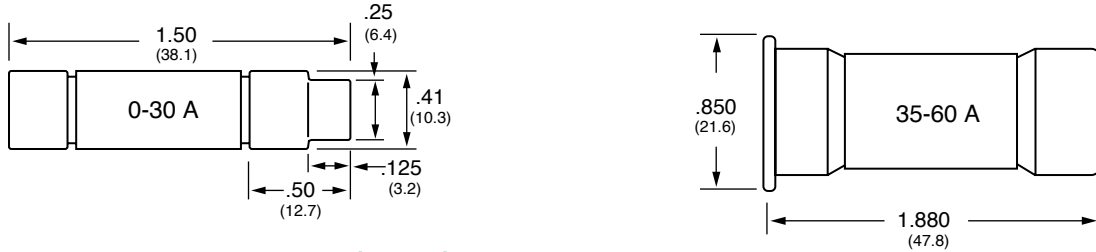

Current-Limiting Effects of CCMR (600 V) fuses

SHORT CIRCUIT CURRENT*	APPARENT RMS SYMMETRICAL CURRENT FOR VARIOUS FUSE RATINGS																	
	2.25A	2.5A	3A	4A	5A	6.25A	7.5A	8A	10A	12A	15A	20A	30A	35A	40A	45A	50A	60A
5,000	203	224	287	289	460	472	442	437	359	369	435	355	621	1,170	1,240	1,320	1,070	1,525
10,000	256	282	361	364	580	595	557	551	452	465	548	447	783	1,480	1,565	1,670	1,355	1,930
15,000	293	323	413	416	664	681	637	631	517	532	627	512	896	1,695	1,795	1,915	1,555	2,200
20,000	323	356	455	458	730	750	702	694	569	585	690	563	987	1,870	1,980	2,110	1,710	2,430
25,000	348	383	490	493	787	808	756	748	613	630	743	607	1,063	2,015	2,135	2,275	1,845	2,620
30,000	370	407	521	524	836	858	803	795	651	670	790	645	1,129	2,145	2,270	2,420	1,965	2,780
35,000	389	429	548	552	880	903	845	837	686	705	832	679	1,189	2,260	2,390	2,550	2,070	2,885
40,000	407	448	573	577	920	944	884	875	717	737	870	709	1,243	2,360	2,500	2,665	2,165	3,025
50,000	438	483	617	622	991	1,017	952	942	772	794	937	764	1,339	2,545	2,695	2,875	2,330	3,200
60,000	466	513	656	661	1,053	1,081	1,012	1,001	821	844	995	812	1,423	2,705	2,865	3,055	2,480	3,350
80,000	513	564	722	727	1,159	1,190	1,114	1,102	903	929	1,096	894	1,566	2,985	3,160	3,365	2,730	3,540
100,000	552	608	778	783	1,249	1,282	1,200	1,187	973	1,001	1,180	963	1,687	3,215	3,405	3,630	2,945	3,685
150,000	632	696	890	897	1,430	1,467	1,373	1,359	1,114	1,146	1,351	1,102	1,931	3,685	3,905	4,160	3,375	4,030
200,000	696	766	980	987	1,574	1,615	1,511	1,496	1,226	1,261	1,487	1,213	2,125	4,060	4,300	4,580	3,720	4,230

*Prospective RMS Symmetrical Amperes Short-Circuit Current
Note: Data Derived from Peak Let-Thru Curves

Peak Let-Thru Curve KLDR

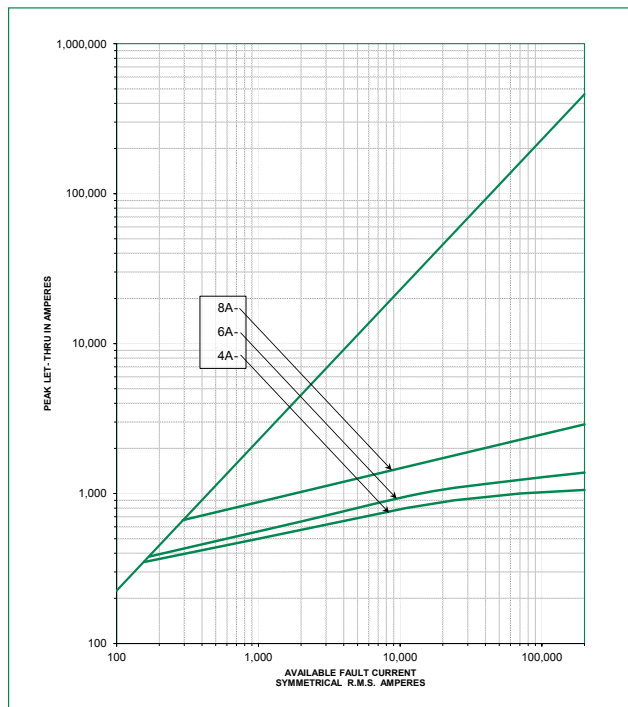

Peak Let-Thru Curve KLKR

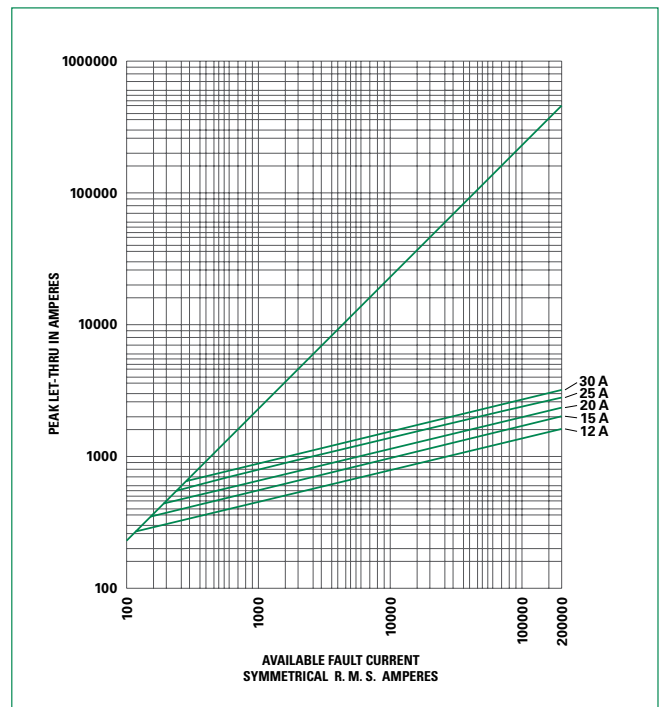

10 x 38mm MIDGET FUSES

UL Supplemental Fuses

KLK Series
Fast-Acting Fuse
600 Vac

UL QPL RoHS CE



AMPERE RATINGS				
1/10	1	5	15	
1/8	1 1/2	6	20	
2/10	2	7	25	
1/4	2 1/2	8	30	
3/10	3	9	—	
1/2	3 1/2	10	—	
3/4	4	12	—	

Specifications

Fast-acting, high-interrupting capacity fuse designed for control circuits, HID lighting, street-lighting, meter circuits.

- Voltage Ratings** 600 Vac
500 Vdc
- Interrupting Ratings** 100 kA @ 600 Vac
50 kA @ 500 Vdc
(capable of 200 kA)
- Approvals** UL Listed (E10480)
CSA Certified (LR29862)
- Dimensions** L 38.1mm (1 1/2")
D 10.31mm (13/32")

littelfuse.com/klk

KLKD Series
Fast-Acting Fuse
600 Vac/dc

UL QPL RoHS CE



AMPERE RATINGS				
1/10	1	5	15	
1/8	1 1/2	6	20	
2/10	2	7	25	
1/4	2 1/2	8	30	
3/10	3	9	—	
1/2	3 1/2	10	—	
3/4	4	12	—	

Specifications

Fast-acting, high DC rated fuse used in solar combiner boxes, DC control circuits, UPS protection. Available in PC board mount.

- Voltage Ratings** 600 Vac/dc
- Interrupting Ratings** 100 kA @ 600 Vac
10 kA @ 600 Vdc (UL 248-19)
50 kA @ 600 Vdc (UL 248-14)
(capable of 200 kA)
- Approvals** UL Listed (E339112 & E10480)
CSA Certified (LR29862)
- Dimensions** L 38.1mm (1 1/2")
D 10.31mm (13/32")

littelfuse.com/klkd

FLM Series
Time-Delay Fuse
250 Vac

UL QPL RoHS Pb



AMPERE RATINGS				
1/10	8/10	2	4 1/2	10
15/100	1	2 1/4	5	12
2/10	1 1/8	2 1/2	5 6/10	15
1/4	1 1/4	2 8/10	6	20
3/10	1 4/10	3	6 1/4	25
4/10	1 1/2	3 2/10	7	30
1/2	1 6/10	3 1/2	8	—
6/10	1 8/10	4	9	—

Specifications

250V time-delay fuses used to protect circuits with high in-rush. Especially suited for supplemental protection of small motors.

- Voltage Ratings** 250 Vac
125 Vdc self-certified @ 10 kA
- Interrupting Ratings** 10 kA @ 250 Vac
- Approvals** UL Listed (File: E10480)
CSA Certified (029862_0_000)
- Dimensions** L 38.1mm (1 1/2")
D 10.31mm (13/32")

littelfuse.com/flm

FLQ Series
Time-Delay Fuse
500 Vac

UL QPL RoHS



AMPERE RATINGS				
1/10	1/2	2	5	12
1/8	6/10	2 1/4	5 6/10	14
15/100	8/10	2 1/2	6	15
3/16	1	3	6 1/4	20
2/10	1 1/8	3 2/10	7	25
1/4	1 1/4	3 1/2	8	30
3/10	1 1/2	4	9	—
4/10	1 6/10	4 1/2	10	—

Specifications

500V time-delay fuses for supplemental protection of control power transformers, solenoids, and circuits with high in-rush. Ideal for 480 V systems.

- Voltage Ratings** 500 Vac
300 Vdc self-certified @ 10 kA
- Interrupting Ratings** 10 kA @ 500V ac
- Approvals** UL Listed (E10480)
CSA Certified (LR29862)
- Dimensions** L 38.1mm (1 1/2")
D 10.31mm (13/32")

littelfuse.com/flq

BLN Series
Fast-Acting Fuse
250 Vac

UL QPL RoHS



AMPERE RATINGS				
1	3	6	12	25
1 1/2	4	8	15	30
2	5	10	20	—

Specifications

250 volt BLN fuses provide low-cost protection for military applications and control circuits.

- Voltage Ratings** 250 Vac
- Interrupting Ratings** 10 kA @ 250 Vac
- Approvals** UL Listed (E10480)
CSA Certified (LR29862)
- Dimensions** L 38.1mm (1 1/2")
D 10.31mm (13/32")

littelfuse.com/bln

BLF Series
Fast-Acting Fuse
125/250 Vac

UL QPL RoHS



AMPERE RATINGS			
1/2	3	7	15
1	4	8	20
1 1/2	5	9	25
2	6	10	30
2 1/2	6 1/4	12	—

Specifications

BLF fuses are the lowest price midget fuse. They are suitable for control circuit and instrument protection in dry locations.

- Voltage Ratings** 250 Vac 1/2 - 15 A
125 Vac 20 - 30 A
- Interrupting Ratings** 10 kA @ rated Vac
- Approvals** UL Listed (E10480)
CSA Certified (LR29862)
- Dimensions** L 38.1mm (1 1/2")
D 10.31mm (13/32")

littelfuse.com/blf

10 x 38mm MIDGET FUSES

BLS Series Fast-Acting Fuse 600 Vac / 250 Vac



AMPERE RATINGS				
2/10	1	3	8	
4/10	1 1/2	4	10	
1/2	1 6/10	5	—	
3/4	1 8/10	6	—	
8/10	2	7	—	

Specifications

Slightly shorter than a traditional 10 x 38, BLS fuses provide space saving protection for low amperage applications.

- Voltage Ratings** 600 Vac 2/10 - 5 A
250 Vac 6 - 10 A
- Interrupting Ratings** 10 kA @ rated Vac
- Approvals** UL Listed (E10480)
CSA Certified (LR29862)
- Dimensions** L 34.9 mm (1 3/8")
D 10.31 mm (13/32")

littelfuse.com/bls

KLO Series Increased Time-Delay 600 Vac



AMPERE RATINGS		
1	2	5
1 6/10	3	6

Specifications

Same physical size as the BLS fuse with more time delay. Designed to protect gaseous vapor fixtures, HID ballasts and other electronic lighting circuits.

- Voltage Ratings** 600 Vac
- Interrupting Ratings** 10 kA @ rated Vac
- Approvals** UL Listed (E10480)
CSA Certified (LR29862)
- Dimensions** L 34.9 mm (1 3/8")
D 10.31 mm (13/32")

littelfuse.com/klq

FLA Series Time-Delay Pin Indicating Fuse 125 Vac



AMPERE RATINGS				
1/10	8/10	2	4 1/2	12*
15/100	1	2 1/4	5	15*
2/10	1 1/8	2 1/2	5 6/10	20*
1/4	1 1/4	2 9/10	6	25*
3/10	1 4/10	3	6 1/4	30*
4/10	1 1/2	3 2/10	7	—
1/2	1 6/10	3 1/2	8	—
6/10	1 8/10	4	10	—

*12-30 A are dual tube design

Specifications

Pin indicating time-delay fuses. Use in conjunction with special fuse blocks to operate mechanical signal switches or energize alarm circuits.

- Voltage Ratings** 125 Vac
- Interrupting Ratings** 10 kA @ rated Vac
- Approvals** UL Listed (E10480)
- Dimensions** L 38.1 mm (1 1/2")
D 10.31 mm (13/32")

littelfuse.com/fla

FLU Series Multimeter Protection 1000 Vac/dc



Specifications

Multimeter protection fuses.

- Voltage Rating** 1000 Vac/Vdc
- Interrupting Rating** 44/100 A: 10 kA
11 A: 20 kA
- Ampere Ratings** 44/100 & 11 A
- Time Constant** 10 ms
- Approvals** UL Recognized (E10480)
CSA Certified (LR29862)
- Dimensions** 44/100 A: 13/32" x 1 3/8"
11 A: 13/32" x 1 1/2"

littelfuse.com/flu

10 x 38mm Midget Fuse Holder Configurations

OPEN FUSE BLOCK



L60030M
pg. 107

PC BOARD MOUNT FUSE BLOCK



L60030MPCB
pg. 109

POWR-SAFE DEAD FRONT HOLDERS



LPSM/LPSC (600 V)
pg. 117



LPHV (1000 V)
pg. 116

Section Overview

Diverse application needs require a broad range of fuses. Littelfuse offers a full line of fuses for various applications. As the market leader in Automotive and Electronics fuses, we are able to deliver innovative circuit protection solutions to our customers. Visit littelfuse.com for our full line of Automotive and Electronics solutions.



ELECTRONIC FUSES AND BLADE FUSES



Table of Contents

Glass / Electronic Fuses	33
Blade / Automotive Fuses	36

HIGH DC VOLTAGE AND PC BOARD MOUNT FUSES

505 Series Lead-Free 3AB, Fast-Acting

RoHS CE



AMPERE RATINGS		
10	16	25
12	20	30

Specifications



A 500 Vac/Vdc rated ceramic fuse with remarkable interrupting rating in a compact 6.3 x 32 mm package, well suited for circuit protection in high energy applications.

Voltage Rating 450 Vac (10 – 12 A)
250 Vdc (10 – 12 A)
500 Vac/dc (16 – 30 A)

Sample Part 0505010.MXP*

Axial Lead 505_XEP Series

Dimensions L 31.75 mm (1.25")
D 6.35 mm (.25")

littelfuse.com/505

*Bulk configurations only

477 Series 5 x 20 mm Slo-Blo® Fuse

RoHS



AMPERE RATINGS			
.5	2	5	10
.8	3.15	6.3	12
1	4	8	16

Specifications



500 Vac/400 Vdc rated, 5 x 20 mm, time-lag, surge withstand ceramic body fuse.

Voltage Rating 500 Vac
400 Vdc

Sample Part 0477002.MXP*

Axial Lead 477_XEP Series

Dimensions L 20 mm (.79")
D 5.2 mm (.20")

littelfuse.com/477

*Bulk configurations only

Dimensions mm (inches)

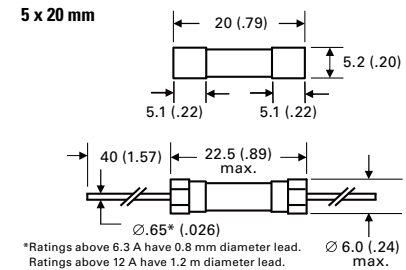
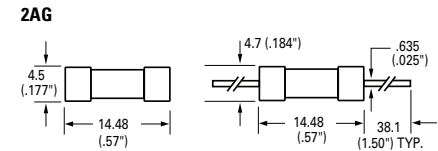
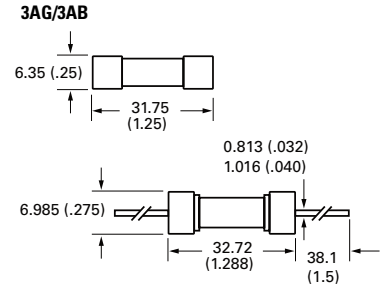

273 Series Very Fast-Acting Microfuse

RoHS



AMPERE RATINGS					
.002	.031	.125	.400	.750	2
.005	.050	.200	.500	.800	3
.010	.062	.250	.600	1	4
.015	.100	.300	.700	1.5	5

Specifications

Similar to 272 and 278 series, except has transparent cap for visual indication of fuse status. *See web for approvals by part.

Voltage Rating 125 Vac/dc

Sample Part 0273002.V

littelfuse.com/273

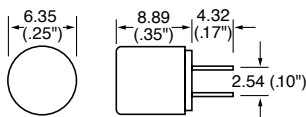

251 Series Fast-Acting Pico® II Fuse

RoHS



AMPERE RATINGS				
.062	.500	1.25	3	7
.125	.630	1.5	3.5	10
.250	.750	2	4	12
.375	1	2.5	5	15

Specifications

Subminiature fuse for soldered mounting on printed circuit boards. Available on tape and reel for automatic insertion. *See web for approvals by part.

Voltage Ratings 125 Vac/dc 1/16 – 10 A
32 Vac/dc 12 – 15 A

Sample Part 0251001.NAT1L

littelfuse.com/251

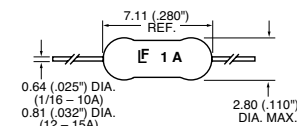

451 Series NANO²® Very Fast-Acting

RoHS



Add "L" suffix when ordering RoHS compliant 451 series

AMPERE RATINGS					
0.062	0.25	0.630	1.5	3.15	7
0.1	0.315	0.750	1.6	3.5	8
0.125	0.375	0.800	2	4	10
0.160	0.400	1	2.5	5	12
0.2	0.5	1.25	3	6.3	15

Specifications

The Nano² SMF Fuse is a very small, Wire-in-Air (WIA) square shape surface mount fuse which is very suitable for the secondary side circuit over-current protection applications and is designed for PCB using surface mount technology
*See web for approvals by part.

Voltage Rating 65 – 125 V

Sample Part 0451.125MP

littelfuse.com/451

LEADED AND CARTRIDGE FUSES

2

Glass / Electronic Fuses

**312/318 Series
3AG Fast-Acting**



AMPERE RATINGS					
.062	.200	.750	1.8	5	15
.100	.250	1	2	6	20
.125	.300	1.25	2.25	7	25
.15	.375	1.5	2.5	8	30
.175	.500	1.6	3	10	35
.187	.600	1.75	4	12	—

Specifications

Designed for fast-acting protection of electronic equipment and appliances. The “standard” fast-acting, glass tube fuse.

Voltage Ratings 250 Vac $\frac{1}{100}$ – 10 A
32 Vac 12 – 35 A

Dimensions L 31.75 mm (1.25")
D 6.35 mm (.25")

Sample Part 0312005.VXP
For fuses with axial leads, request 318 Series.

littelfuse.com/312

**313/315 Series
3AG Slo-Blo®**



AMPERE RATINGS						
.010	.175	.500	1.25	2.8	7	30
.031	.187	.600	1.5	3	8	—
.040	.200	.700	1.6	3.2	10	—
.062	.250	.750	1.8	4	12	—
.100	.300	.800	2	5	15	—
.125	.375	1	2.25	6.25	20	—
.150	.400	1.2	2.5	6.3	25	—

Specifications

313 and 315 series fuses have time-delay in the overload range, providing superior protection for inductive loads. ID feature available which discolors upon opening.

Voltage Ratings 250 Vac $\frac{1}{100}$ – 8 A
32 Vac 10 – 30 A

Dimensions L 31.75 mm (1.25")
D 6.35 mm (.25")

Sample Part 0313005.VXP
For fuses with axial leads, request 315 Series.
For Fuses with ID, add “ID” suffix.

littelfuse.com/313

**314/324 Series
3AB Fast-Acting**



AMPERE RATINGS				
.375	2	6	12	30
.500	3	7	15	40
.750	4	8	20	—
1	5	10	25	—

Specifications

Similar to 312 series, but ceramic tube permits higher interrupting ratings and voltage ratings: 250 volt ratings to 40 amps.

Voltage Rating 250 Vac $\frac{3}{8}$ – 40 A
125 Vdc $\frac{3}{8}$ – 30 A
150 Vdc 40 A

Dimensions L 31.75 mm (1.25")
D 6.35 mm (.25")

Sample Part 03145005.VXP
For fuses with axial leads, request 324 Series.

littelfuse.com/314

**326/325 Series
3AB Slo-Blo®**



AMPERE RATINGS					
.010	.187	.600	1.5	4	15
.031	.200	.700	1.6	5	20
.062	.250	.750	2	6.25	25
.100	.300	.800	2.5	7	30
.125	.375	1	2.8	8	—
.150	.400	1.2	3	10	—
.175	.500	1.25	3.2	12	—

Specifications

The 326 series fuse has time-delay similar to the 313 series, but the ceramic body permits higher voltage ratings for the 8 – 30 ampere sizes and faster opening of short-circuits.

Voltage Ratings 250 Vac $\frac{1}{100}$ – 30 A
125 Vdc $\frac{1}{4}$ – 3 A
125 Vdc 12 – 30 A

Dimensions L 31.75 mm (1.25")
D 6.35 mm (.25")

Sample Part 0326.100VXP
For fuses with axial leads, request 325 Series.

littelfuse.com/326

**229/230 Series
2AG Slo-Blo®**



AMPERE RATINGS			
.250	.750	2	4
.350	.800	2.25	5
.375	1	2.5	6
.500	1.25	3	7
.600	1.5	3.5	—

Specifications

2AG indicating fuses instantly identify themselves upon opening by showing a discoloration of their glass bodies, eliminating guesswork. This unique design offers the same quality performance characteristics as the standard 2AG fuse design.*

Voltage Ratings 250 Vac $\frac{1}{4}$ – 3 $\frac{1}{2}$ A
125 Vac 4 – 7 A
125 Vdc $\frac{1}{4}$ – 7 A

Dimensions L 14.48 mm (.57")
D 4.5 mm (.177")

Sample Part 02291.25VXP
For fuses with axial leads, request 230 Series.

*Must add “S” suffix when ordering indicating fuse

littelfuse.com/229

**225/224 Series
2AG Fast-Acting**



AMPERE RATINGS				
.375	1	2.5	4	7
.500	1.5	3	5	8
.750	2	3.5	6	10

Specifications

Fast-acting performance of the 312 series 3AG fuses in less than one-third the space. For protection of electronic equipment and appliances.

Voltage Ratings 250 Vac $\frac{3}{8}$ – 3 $\frac{1}{2}$ A
125 Vac 4 – 10 A
125 Vdc $\frac{3}{8}$ – 3 $\frac{1}{2}$ A

Dimensions L 14.48 mm (.57")
D 4.5 mm (.177")

Sample Part 0225003.VXP
For fuses with axial leads, request 224 Series.

littelfuse.com/225

Note: All fuses on this page are available in packaged and bulk configurations

5 x 20 mm IEC LEADED AND CARTRIDGE FUSES

215 Series 5 x 20 mm IEC Slo-Blo®



AMPERE RATINGS						
.125	.315	.800	2	5	12	
.160	.400	1	2.5	6.3	15	
.200	.500	1.25	3.15	8	16	
.250	.630	1.6	4	10	20	

Specifications

Time-delay protection of electronic equipment and appliances when fuses to International Standards are required. Replacement fuse for foreign equipment.

Voltage Rating 250 Vac
Dimensions L 20 mm (.79")
D 5.2 mm (.20")
Sample Part 0215005.VXP
 For fuses with axial leads, request 215_XEP series.
littelfuse.com/215

216 Series 5 x 20 mm IEC Fast-Acting



AMPERE RATINGS						
.050	.125	.315	1	2.5	6.3	16
.063	.160	.500	1.25	3.15	8	—
.080	.200	.630	1.6	4	10	—
.100	.250	.800	2	5	12.5	—

Specifications

Fast-acting protection of electronic equipment and appliances when fuses to International Standards are required. Replacement fuse for foreign equipment.

Voltage Rating 250 Vac
 60 Vdc (1.25-3.15, 4-6.3 A only)
Dimensions L 20 mm (.79")
D 5.2 mm (.20")
Sample Part 0216005.VXP
 For fuses with axial leads, request 216_XEP series.
littelfuse.com/216

217 Series 5 x 20 mm IEC Fast-Acting



AMPERE RATINGS						
.032	.100	.250	.630	1.6	4	10
.050	.125	.315	.800	2	5	15
.063	.160	.400	1	2.5	6.3	—
.080	.200	.500	1.25	3.15	8	—

Specifications

Fast-acting protection of electronic equipment and appliances when fuses to International Standards are required. Replacement fuse for foreign equipment.

Voltage Rating 250 Vac
 75Vdc (2-3.15 A only)
 60 Vdc (6.3, 2.-5 A only)
Dimensions L 20 mm (.79")
D 5.2 mm (.20")
Sample Part 0217005.VXP
 For fuses with axial leads, request 217_XEP series.
littelfuse.com/217

218 Series 5 x 20 mm IEC Slo-Blo®



AMPERE RATINGS						
.032	.100	.315	1	3.15	10	
.040	.125	.400	1.25	4	12.5	
.050	.160	.500	1.6	5	15	
.063	.200	.630	2	6.3	16	
.080	.250	.800	2.5	8	—	

Specifications

Time-delay protection of electronic equipment and appliances when fuses to International Standards are required. Replacement fuse for foreign equipment.

Voltage Rating 250 Vac
Dimensions L 20 mm (.79")
D 5.2 mm (.20")
Sample Part 0218005.VXP
 For fuses with axial leads, request 218_XEP series.
littelfuse.com/218

235 Series 5 x 20 mm UL/CSA Fast-Acting



AMPERE RATINGS						
.100	.300	.700	1.60	3.5	7	
.125	.400	.800	2	4	—	
.200	.500	1	2.5	5	—	
.250	.600	1.25	3	6	—	

Specifications

5 x 20 mm fuses designed to UL and CSA standards. Fast-acting protection of electronic equipment and appliances.

Voltage Ratings 250 Vac 1/10 – 3 1/2 A
 125 Vac 4 – 7 A
Dimensions L 20 mm (.79")
D 5.2 mm (.20")
Sample Part 0235005.VXP
 For fuses with axial leads, request 235_XEP series.
littelfuse.com/235

239 Series 5 x 20 mm UL/CSA Slo-Blo®



AMPERE RATINGS						
.080	.200	.500	.800	2	3.20	7
.100	.250	.600	1	2.5	3.50	—
.125	.300	.700	1.25	3	4	—
.150	.400	.750	1.60	3.15	5	—

Specifications

5 x 20 mm fuses designed to UL and CSA standards. Time-delay protection of electronic equipment and appliances.

Voltage Ratings 250 Vac 2/10 – 3 1/2 A
 125 Vac 4 – 7 A
Dimensions L 20 mm (.79")
D 5.2 mm (.20")
Sample Part 0239005.VXP
 For fuses with axial leads, request 239_XEP series.
littelfuse.com/239

Note: All fuses on this page are available in packaged and bulk configurations

BLADE FUSES

Blade / Automotive Fuses

2

**MINI®
Smart Glow**

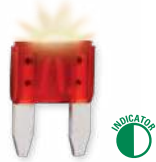

Specifications

Smart Glow fuses are innovative automotive style fuses (ATO, MINI, and MAXI) that feature an indicator light that glows when the fuse is blown, saving time to troubleshoot an open circuit.

Voltage Rating 14 Vdc
Sample Part OMIN010.VPGLO

MINI Fuses are available in packaged and bulk configurations. See 297 series on web.

MINI® Fast-Acting



Specifications

The MINI® Fuse, with its miniature design patented by Littelfuse, meets the need for more circuits to be protected while utilizing less space.

Voltage Rating 32 Vdc
Sample Part OMIN020.V
littelfuse.com/mini

**Fuses Rated 58 V
Low Profile MINI®**



Specifications

The low profile MINI has similar performance as the standard mini fuse. The lower overall height allows for more space and weight savings.

Voltage Rating 58 Vdc
Sample Part LMIN010.V
littelfuse.com/lmini

MINI dimensions in mm

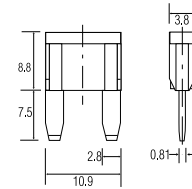

Low Profile MINI dimensions in mm (inches)

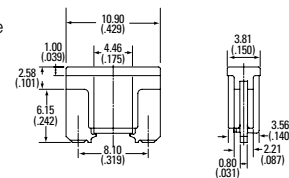

**ATO®
Smart Glow**



Specifications

Smart Glow fuses are innovative automotive style fuses (ATO, MINI, and MAXI) that feature indicator light that glows when the fuse is blown, saving time to troubleshoot an open circuit.

Voltage Rating 14 Vdc
Sample Part OATO010.VPGLO

ATO Fuses are available in packaged and bulk configurations. See 287 series on web.

ATO® Fast-Acting



Specifications

The ATO® Fuse was designed and patented by Littelfuse in 1976 and set the standard for automotive circuit protection. It features industry standard color coding to indicate amperage rating.

Voltage Rating 32 Vac/dc
Sample Part OATO020.V
littelfuse.com/ato

ATO dimensions in mm (inches)

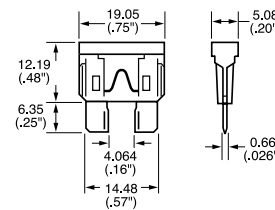

**ATO® / MINI®
Color Key**

CURRENT RATING	HOUSING COLOR
1 A	Black
2 A	Grey
3 A	Purple
4 A	Pink
5 A	Brown
7.5 A	Dark Brown
10 A	Red
15 A	Blue
20 A	Yellow
25 A	White
30 A	Green
40 A	Orange

Note: MINI not available in 1 A or 40 A.

**MAXI™
Smart Glow**

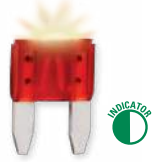

Specifications

Smart Glow fuses are innovative automotive style fuses (ATO, MINI, and MAXI) that feature an indicator light that glows when the fuse is blown, saving time to troubleshoot an open circuit.

Voltage Rating 14 Vdc
Sample Part OMAX030.XPGLO

MAXI Fuses are available in packaged and bulk configurations. See 299 series on web.

MAXI™ Slo-Blo



Specifications

Designed and patented by Littelfuse, the MAXI™ Fuse is ideal for motor powered applications which have large inrush currents.

Voltage Rating 32 Vdc
Sample Part OMAX030.X
littelfuse.com/maxi

MAXI dimensions in mm (inches)

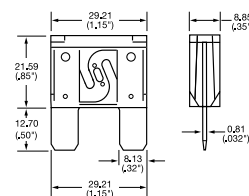

**MAXI™
Color Key**

CURRENT RATING	HOUSING COLOR
20 A	Yellow
25 A	Grey
30 A	Green
35 A	Brown
40 A	Orange
50 A	Red
60 A	Blue
70 A	Dark Brown
80 A	White

BLADE FUSES

FHA Blade Fuse Holders—In-Line Fuse Holder for ATO® Style Blade Fuse

RoHS



Dimensions in mm

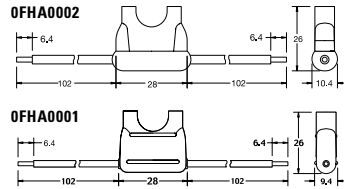

PART NUMBER	DESCRIPTION	FUSE RATING
0FHA0001_	16AWG/1.3mm ² STRANDED BLACK WIRE	20 A
0FHA0002_	12AWG/3.3mm ² STRANDED ORANGE WIRE	30 A

Used with ATO Fuse 1 to 20 A or 25 A and 30 A. Supplied with two 4" (102mm) wire leads.

littelfuse.com/fha

Wire length, color and diameter can be customized upon request.

FHAC Blade Fuse Holders—In-Line Splash-Waterproof Fuse Holder for ATO® Style Blade Fuse

RoHS



Dimensions in mm

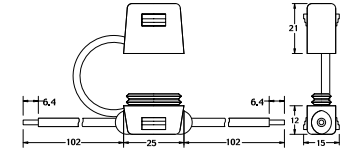

PART NUMBER	DESCRIPTION	FUSE RATING
FHAC0001_	16AWG/1.3mm ² STRANDED BLACK WIRE	20 A
FHAC0002_	12AWG/3.3mm ² STRANDED ORANGE WIRE	30 A

Used with ATO Fuse 1 to 20 A or 25 A and 30 A. Supplied with two 4" (102mm) wire leads. Includes protective cover for harsh environments.

littelfuse.com/fha

Wire length, color and diameter can be customized upon request.

FHM Blade Fuse Holders—In-Line Splash-Waterproof Fuse Holder for MINI® Style Blade Fuse

RoHS

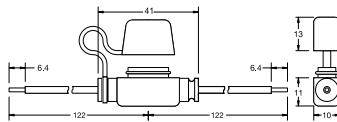

PART NUMBER	DESCRIPTION	FUSE RATING
0FHM0001_	14AWG/2.1mm ² STRANDED BLACK WIRE	20 A
0FHM0002_	12AWG/3.3mm ² STRANDED ORANGE WIRE	30 A

Used with MINI Fuse 1 to 20 A or 25 A and 30 A. Supplied with two 4.78" (122 mm) wire leads. Includes protective cover for harsh environment.

littelfuse.com/fhm

Wire length, color and diameter can be customized upon request.

MAH Blade Fuse Holders—In-Line Fuse Holder for MAXI™ Style Blade Fuse



Dimensions in mm

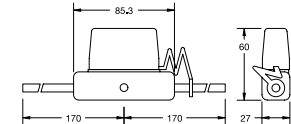

PART NUMBER	DESCRIPTION	FUSE RATING
0MAH0001Z	WIRE COLOR BLACK	60 A

Supplied with two 6", 6-gauge wire leads for up to 60 A MAXI Fuse applications, this In-Line Fuse holder also provides a protective cover for harsh under-the-hood environments. Mounting hole permits easy bulkhead installation.

littelfuse.com/mah

JCASE® Cartridge Fuse Rated 32 V

RoHS Pb



Specifications

The JCASE is a cartridge style fuse with female terminal design. JCASE provides both increased time delay and low voltage drop to protect high current circuits. JCASE has the ability to handle in-rush currents. The JCASE was designed and patented by Littelfuse.

littelfuse.com/jcase

Low Profile JCASE® Fuse Rated 58 V

RoHS Pb



Specifications

The Low Profile JCASE fuse has similar performance characteristics as the standard JCASE fuse. The lower overall height reduction allows for more space and weight savings and also allows for a shorter male blade terminal, saving additional weight and material savings in fuse box designs.

JCASE® 32 V Dimensions in mm

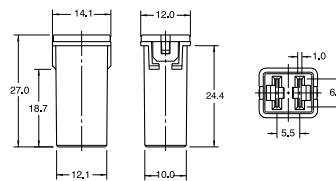

Low Profile JCASE® 58 V Dimensions in mm

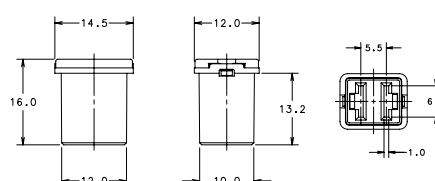

JCASE® Color Key

CURRENT RATING	HOUSING COLOR
20 A	Blue
25 A	White
30 A	Pink
40 A	Green
50 A	Red
60 A	Yellow

Section Overview

Littelfuse is your source for a fast replacement of E- and R-rated medium voltage fuses. Our emergency service gets you the fuses you need quickly to minimize downtime of your critical operations.



MEDIUM VOLTAGE FUSES

Table of Contents

Medium Voltage Fuses Overview	39
R-Rated Medium Voltage Fuses	40
E-Rated Medium Voltage Fuses	42
Medium Voltage Live Parts.....	48

MEDIUM VOLTAGE FUSES

2,400-38,000 Vac • Current-Limiting



Description

Littelfuse® offers a selection of E- and R-rated medium voltage fuses for the protection of transformers, potential transformers, feeders, and motor circuits. Single, double, and triple barrel designs are available to cover a wide range of current, voltage, and interrupting ratings. Conventional ferrule type, clip lock, and bolt-in mounting configurations are available for virtually any application. Hermetically sealed fuses for use in hazardous environments are also offered.

Contact the factory or your local Littelfuse representative for additional fuse ratings or custom mounting configurations.

24-Hour Emergency Service - Call 800-227-0029

Applications

- Power Transformer Protection
- Potential Transformer Protection
- Motor Controller Back-up Protection
- Fused Switches
- Feeder Circuits



Current-limiting E- and R-rated fuses are equipped with a mechanical indicator or striker pin that protrudes through the fuse cap upon operation of the fuse. This provides visual identification of a blown fuse and can be used as a trigger for external devices.

Note: Extension distance 1/2" minimum; extension force 2 lb. minimum.

General Information

The terms "Medium Voltage" and "High Voltage" have been used interchangeably by many people to describe fuses operating above 600 volts. Technically speaking, medium voltage fuses are those intended for the voltage range from 2,400 to 38,000 Vac. High voltage fuses are for circuits carrying voltages greater than 38,000 Vac.

E-rated fuses are considered to be general purpose fuses and can be used to protect against low and high values of fault current. R-rated fuses are designed for back-up protection. They must be used in series with other devices such as motor overload relays in order to achieve both overload and short-circuit protection.

Medium voltage fuses are not intended to provide overload protection in the same sense as fuses rated 600 volts or less. Medium voltage fuse current ratings do not have the same meanings as the ampere ratings of low voltage fuses.

All medium voltage fuses are limited in their ability to interrupt low value overcurrents, especially those between 100% and 200% of the fuse's continuous current rating. They are designed to carry their rated current without exceeding the temperature rise permitted by NEMA and ANSI standards.



Bolt-in Mount Fuses

R-RATED MEDIUM VOLTAGE FUSES

3
Medium Voltage Fuses

Description

R-rated fuses provide required short-circuit protection for medium voltage motors, motor controllers and associated circuitry. These components have limited ability to absorb the energy of large short-circuit currents. Medium voltage motor controllers contain overload relays which provide both overload protection and locked rotor protection to the motor. The controllers are also intended to interrupt low value short-circuits within the capability of the motor controller. This protects the medium voltage fuse from sustained overcurrents which are less than their minimum interrupting rating.

NEMA Standards for R-rated medium voltage power fuses require they operate within 15-35 seconds when subjected to an rms current 100 times the R rating. For example, a fuse with a 2R rating will open within 15 to 35 seconds on an applied current of $2 \times 100 = 200$ amperes.

Ordering Number

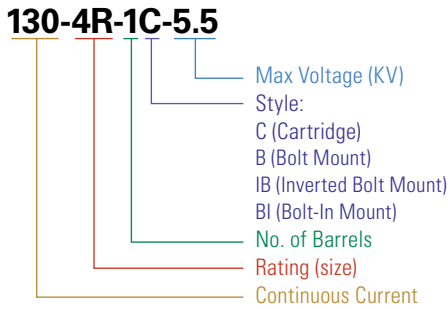

Dimensions

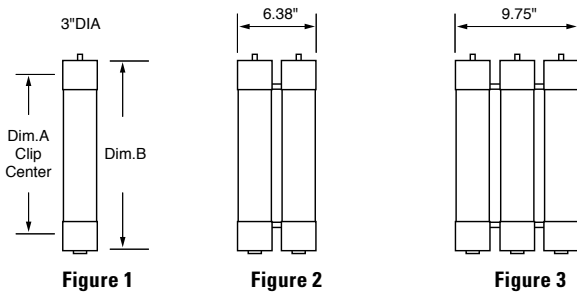

Cartridge "C"

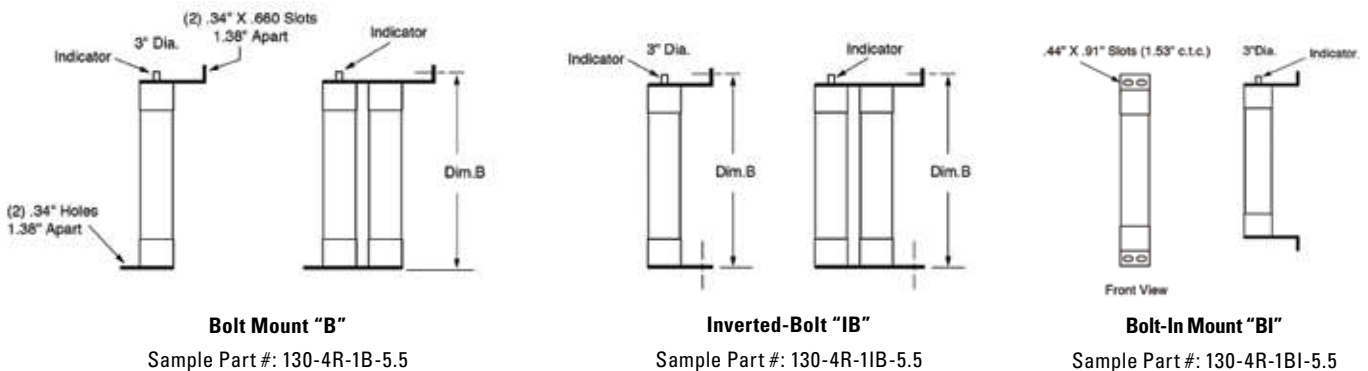

Characteristics

Voltage Ratings 2,750 V – 8,250 V
Current Range 2R – 36R

Options

- Hermetically sealed for use in hazardous locations (add "S" suffix to part number)
- Bolt-in mounting configurations



Hookeye Feature*

For hookeye attachment; add "W" suffix to part number

*See web for Bolt Mount, Inverted Bolt Mount, and Bolt-In dimensions

Medium Voltage Fuse Protection

POWR-GARD® medium voltage fuses provide short-circuit protection for motors and transformers rated 2,400 to 38,000 volts AC. Visit littelfuse.com/MediumVoltage to download the white paper featuring protection tables, sizing recommendations, and applications.



R-RATED MEDIUM VOLTAGE FUSES

3 Medium Voltage Fuses

R RATED	ORDERING/CATALOG NUMBER	SIZE	MAXIMUM CONTINUOUS CURRENT @ 40 DEGREES C°	DIM. A (INCHES)	DIM. B (INCHES)	MINIMUM INTERRUPTING RATING RMS AMPS	MAXIMUM INTERRUPTING RATING RMS (ASYM)*	FIGURE NUMBER
2.75 KV	702R1C2.75	2R	70	7"	10.875"	170	80,000	1
	1003R1C2.75	3R	100	7"	10.875"	250	80,000	1
	1304R1C2.75	4R	130	7"	10.875"	340	80,000	1
	1505R1C2.75	5R	150	7"	10.875"	390	80,000	1
	1706R1C2.75	6R	170	7"	10.875"	500	80,000	1
	2009R1C2.75	9R	200	7"	10.875"	760	80,000	1
	23012R1C2.75	12R	230	7"	10.875"	1000	80,000	1
	39018R2C2.75	18R	390	7"	10.875"	1500	80,000	2
45024R2C2.75	24R	450	7"	10.875"	1950	80,000	2	

R RATED	ORDERING/CATALOG NUMBER	SIZE	MAXIMUM CONTINUOUS CURRENT @ 40 DEGREES C°	DIM. A (INCHES)	DIM. B (INCHES)	MINIMUM INTERRUPTING RATING RMS AMPS	MAXIMUM INTERRUPTING RATING RMS (ASYM)*	FIGURE NUMBER
5.5 KV	702R1C5.5	2R	70	12"	15.875"	170	80,000	1
	1003R1C5.5	3R	100	12"	15.875"	250	80,000	1
	1304R1C5.5	4R	130	12"	15.875"	340	80,000	1
	1505R1C5.5	5R	150	12"	15.875"	390	80,000	1
	1706R1C5.5	6R	170	12"	15.875"	500	80,000	1
	2009R1C5.5	9R	200	12"	15.875"	760	80,000	1
	23012R1C5.5	12R	230	12"	15.875"	1000	80,000	1
	39018R2C5.5	18R	390	12"	15.875"	1500	80,000	2
	45024R2C5.5	24R	450	12"	15.875"	1950	80,000	2
	48026R2C5.5	26R	480	12"	15.875"	2100	80,000	2
	55030R2C5.5	30R	550	12"	15.875"	2400	80,000	2
	60032R2C5.5	32R	600	12"	15.875"	2600	80,000	2
	65036R2C5.5	36R	650	12"	15.875"	2900	80,000	2
	55030R3C5.5	30R	550	12"	15.875"	2400	80,000	3
60032R3C5.5	32R	600	12"	15.875"	2600	80,000	3	
65036R3C5.5	36R	650	12"	15.875"	2900	80,000	3	

R RATED	ORDERING/CATALOG NUMBER	SIZE	MAXIMUM CONTINUOUS CURRENT @ 40 DEGREES C°	DIM. A (INCHES)	DIM. B (INCHES)	MINIMUM INTERRUPTING RATING RMS AMPS	MAXIMUM INTERRUPTING RATING RMS (ASYM)*	FIGURE NUMBER
5.5 KV 14" CLIP CENTERS	702R1C5.5X	2R	70	14"	17.875"	170	80,000	1
	1003R1C5.5X	3R	100	14"	17.875"	250	80,000	1
	1304R1C5.5X	4R	130	14"	17.875"	340	80,000	1
	1505R1C5.5X	5R	150	14"	17.875"	390	80,000	1
	1706R1C5.5X	6R	170	14"	17.875"	500	80,000	1
	2009R1C5.5X	9R	200	14"	17.875"	760	80,000	1
	23012R1C5.5X	12R	230	14"	17.875"	1000	80,000	1
	39018R2C5.5X	18R	390	14"	17.875"	1500	80,000	2
	45024R2C5.5X	24R	450	14"	17.875"	1950	80,000	2
	55030R2C5.5X	30R	550	14"	17.875"	2400	80,000	2

R RATED	ORDERING/CATALOG NUMBER	SIZE	MAXIMUM CONTINUOUS CURRENT @ 40 DEGREES C°	DIM. A (INCHES)	DIM. B (INCHES)	MINIMUM INTERRUPTING RATING RMS AMPS	MAXIMUM INTERRUPTING RATING RMS (ASYM)*	FIGURE NUMBER
8.25 KV	702R1C8.25	2R	70	12"	15.875"	190	80,000	1
	1003R1C8.25	3R	100	12"	15.875"	225	80,000	1
	1304R1C8.25	4R	130	12"	15.875"	330	80,000	1
	1505R1C8.25	5R	150	12"	15.875"	440	80,000	1
	1706R1C8.25	6R	170	12"	15.875"	500	80,000	1
	2009R1C8.25	9R	200	12"	15.875"	740	80,000	1
	23012R1C8.25	12R	230	12"	15.875"	955	80,000	1
	39018R2C8.25	18R	390	12"	15.875"	1440	80,000	2
	45024R2C8.25	24R	450	12"	15.875"	1910	80,000	2

* RMS Asymmetrical amperes = RMS Symmetrical amperes x 1.6
For hokey attachment add "W" suffix to part number

E-RATED MEDIUM VOLTAGE FUSES

Description

E-rated fuses have time current characteristics designed to provide current-limiting protection for power transformers, potential transformers, power centers, feeder centers, and unit sub stations. When properly applied, they can protect against high and low fault currents.

NEMA Standards for E-rated medium voltage fuses require that fuses rated 100E or less open within 300 seconds (5 minutes) when subjected to an RMS value of 200-240% of the fuse continuous current rating; and fuses with an E rating larger than 100E must open within 600 seconds (10 minutes) when subjected to an RMS current of 220-240% of the fuse's continuous current rating. These values establish one point on the time-current curve.

Application Note

Since these fuses are used for the protection of general purpose circuits which may contain transformers, motors, and other equipment producing in-rush and/or overload currents, fuses should generally be rated at 140% of the normal full load current, and circuits should be analyzed to ensure that system load currents will not exceed the current rating of the fuse.

Characteristics

Voltage Ratings 2,750 V – 38,000 V
Current Range 10E – 600E

Options

- Hermetically sealed for use in hazardous locations (add "S" suffix to part number)
- Clip-lock (CL) available.

Dimensions

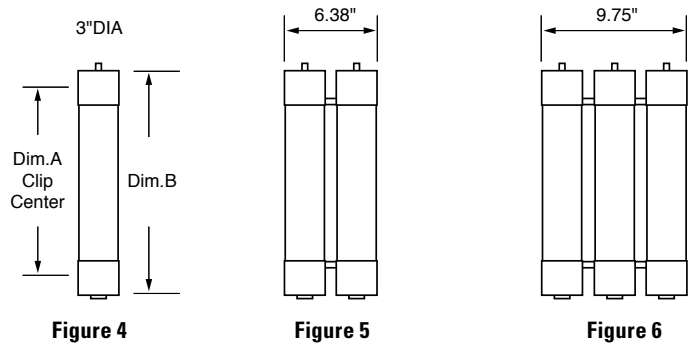

3 Medium Voltage Fuses

E-RATED	ORDERING/CATALOG NUMBER	SIZE	DIM. A (INCHES)	DIM. B (INCHES)	MAX INTERRUPTING RATING RMS (ASYM)*	FIGURE NUMBER
2.75 MAX. KV	10E1C2.75	10E	7"	10.875"	80,000	4
	15E1C2.75	15E	7"	10.875"	80,000	4
	20E1C2.75	20E	7"	10.875"	80,000	4
	25E1C2.75	25E	7"	10.875"	80,000	4
	30E1C2.75	30E	7"	10.875"	80,000	4
	40E1C2.75	40E	7"	10.875"	80,000	4
	50E1C2.75	50E	7"	10.875"	80,000	4
	65E1C2.75	65E	7"	10.875"	80,000	4
	80E1C2.75	80E	7"	10.875"	80,000	4
	100E-1C2.75	100E	7"	10.875"	80,000	4
	125E1C2.75	125E	7"	10.875"	80,000	4
	150E1C2.75	150E	7"	10.875"	80,000	4
	200E1C2.75	200E	7"	10.875"	80,000	4
	125E2C2.75	125E	7"	10.875"	80,000	5
	150E2C2.75	150E	7"	10.875"	80,000	5
	200E2C2.75	200E	7"	10.875"	80,000	5
	250E2C2.75	250E	7"	10.875"	80,000	5
	300E2C2.75	300E	7"	10.875"	80,000	5
	350E2C2.75	350E	7"	10.875"	80,000	5
	400E2C2.75	400E	7"	10.875"	80,000	5
450E2C2.75	450E	7"	10.875"	80,000	5	

*RMS Asymmetrical amperes = RMS Symmetrical amperes x 1.6

E-RATED MEDIUM VOLTAGE FUSES

3
Medium Voltage Fuses

E-RATED	ORDERING/CATALOG NUMBER	SIZE	DIM. A (INCHES)	DIM. B (INCHES)	MAX INTERRUPTING RATING RMS (ASYM)*	FIGURE NUMBER
5.5 MAX. KV	10E1C5.5	10E	12"	15.875"	80,000	4
	15E1C5.5	15E	12"	15.875"	80,000	4
	20E1C5.5	20E	12"	15.875"	80,000	4
	25E1C5.5	25E	12"	15.875"	80,000	4
	30E1C5.5	30E	12"	15.875"	80,000	4
	40E1C5.5	40E	12"	15.875"	80,000	4
	50E1C5.5	50E	12"	15.875"	80,000	4
	65E1C5.5	65E	12"	15.875"	80,000	4
	80E1C5.5	80E	12"	15.875"	80,000	4
	100E1C5.5	100E	12"	15.875"	80,000	4
	125E1C5.5	125E	12"	15.875"	80,000	4
	150E1C5.5	150E	12"	15.875"	80,000	4
	175E1C5.5	175E	12"	15.875"	80,000	4
	200E1C5.5	200E	12"	15.875"	80,000	4
	125E2C5.5	125E	12"	15.875"	80,000	5
	150E2C5.5	150E	12"	15.875"	80,000	5
	200E2C5.5	200E	12"	15.875"	80,000	5
	250E2C5.5	250E	12"	15.875"	80,000	5
	300E2C5.5	300E	12"	15.875"	80,000	5
	350E2C5.5	350E	12"	15.875"	80,000	5
	400E2C5.5	400E	12"	15.875"	80,000	5
	450E2C5.5	450E	12"	15.875"	80,000	5
500E3C5.5	500E	12"	15.875"	80,000	6	
550E3C5.5	550E	12"	15.875"	80,000	6	
600E3C5.5	600E	12"	15.875"	80,000	6	

E-RATED	ORDERING/CATALOG NUMBER	SIZE	DIM. A (INCHES)	DIM. B (INCHES)	MAX INTERRUPTING RATING RMS (ASYM)*	FIGURE NUMBER
5.5 MAX. KV	5NLE10E	10E	14"	17 $\frac{7}{8}$ "	80,000	4
	5NLE15E	15E	14"	17 $\frac{7}{8}$ "	80,000	4
	5NLE20E	20E	14"	17 $\frac{7}{8}$ "	80,000	4
	5NLE25E	25E	14"	17 $\frac{7}{8}$ "	80,000	4
	5NLE30E	30E	14"	17 $\frac{7}{8}$ "	80,000	4
	5NLE40E	40E	14"	17 $\frac{7}{8}$ "	80,000	4
	5NLE50E	50E	14"	17 $\frac{7}{8}$ "	80,000	4
	5NLE65E	65E	14"	17 $\frac{7}{8}$ "	80,000	4
	5NLE80E	80E	14"	17 $\frac{7}{8}$ "	80,000	4
	5NLE100E	100E	14"	17 $\frac{7}{8}$ "	80,000	4
	5NLE125E	125E	14"	17 $\frac{7}{8}$ "	80,000	4
	5NLE150E	150E	14"	17 $\frac{7}{8}$ "	80,000	4
	5NLE175E	175E	14"	17 $\frac{7}{8}$ "	80,000	4
	5NLE200E	200E	14"	17 $\frac{7}{8}$ "	80,000	4
	5NLE2225E	225E	14"	17 $\frac{7}{8}$ "	80,000	5
	5NLE2250E	250E	14"	17 $\frac{7}{8}$ "	80,000	5
	5NLE2300E	300E	14"	17 $\frac{7}{8}$ "	80,000	5
	5NLE2350E	350E	14"	17 $\frac{7}{8}$ "	80,000	5
	5NLE2400E	400E	14"	17 $\frac{7}{8}$ "	80,000	5
	5NLE2450E	450E	14"	17 $\frac{7}{8}$ "	80,000	5

* RMS Asymmetrical amperes = RMS Symmetrical amperes x 1.6

E-RATED MEDIUM VOLTAGE FUSES

 3
 Medium Voltage Fuses

E-RATED	ORDERING/CATALOG NUMBER	SIZE	DIM. A (INCHES)	DIM. B (INCHES)	MAX INTERRUPTING RATING RMS (ASYM)*	FIGURE NUMBER
8.25 MAX. KV	10E1C8.25	10E	12"	15 ⁷ / ₈ "	80,000	4
	15E1C8.25	15E	12"	15 ⁷ / ₈ "	80,000	4
	20E1C8.25	20E	12"	15 ⁷ / ₈ "	80,000	4
	25E1C8.25	25E	12"	15 ⁷ / ₈ "	80,000	4
	30E1C8.25	30E	12"	15 ⁷ / ₈ "	80,000	4
	40E1C8.25	40E	12"	15 ⁷ / ₈ "	80,000	4
	50E1C8.25	50E	12"	15 ⁷ / ₈ "	80,000	4
	65E1C8.25	65E	12"	15 ⁷ / ₈ "	80,000	4
	80E1C8.25	80E	12"	15 ⁷ / ₈ "	80,000	4
	100E1C8.25	100E	12"	15 ⁷ / ₈ "	80,000	4
	125E1C8.25	125E	12"	15 ⁷ / ₈ "	80,000	4
	150E1C8.25	150E	12"	15 ⁷ / ₈ "	80,000	4
	125E2C8.25	125E	12"	15 ⁷ / ₈ "	80,000	5
	150E2C8.25	150E	12"	15 ⁷ / ₈ "	80,000	5
	200E2C8.25	200E	12"	15 ⁷ / ₈ "	80,000	5
	250E2C8.25	250E	12"	15 ⁷ / ₈ "	80,000	5
	300E2C8.25	300E	12"	15 ⁷ / ₈ "	80,000	5
	350E3C8.25	350E	12"	15 ⁷ / ₈ "	80,000	6
400E3C8.25	400E	12"	15 ⁷ / ₈ "	80,000	6	

E-RATED	ORDERING/CATALOG NUMBER	SIZE	DIM. A (INCHES)	DIM. B (INCHES)	MAX INTERRUPTING RATING RMS (ASYM)*	FIGURE NUMBER
8.25 MAX. KV	8NLE10E	10E	14"	17 ⁷ / ₈ "	80,000	4
	8NLE15E	15E	14"	17 ⁷ / ₈ "	80,000	4
	8NLE20E	20E	14"	17 ⁷ / ₈ "	80,000	4
	8NLE25E	25E	14"	17 ⁷ / ₈ "	80,000	4
	8NLE30E	30E	14"	17 ⁷ / ₈ "	80,000	4
	8NLE40E	40E	14"	17 ⁷ / ₈ "	80,000	4
	8NLE50E	50E	14"	17 ⁷ / ₈ "	80,000	4
	8NLE65E	65E	14"	17 ⁷ / ₈ "	80,000	4
	8NLE80E	80E	14"	17 ⁷ / ₈ "	80,000	4
	8NLE100E	100E	14"	17 ⁷ / ₈ "	80,000	4
	8NLE2100E	100E	14"	17 ⁷ / ₈ "	80,000	5
	8NLE2125E	125E	14"	17 ⁷ / ₈ "	80,000	5
	8NLE2150E	150E	14"	17 ⁷ / ₈ "	80,000	5
	8NLE2200E	200E	14"	17 ⁷ / ₈ "	80,000	5
8NLE2250E	250E	14"	17 ⁷ / ₈ "	80,000	5	

E-RATED	ORDERING/CATALOG NUMBER	SIZE	DIM. A (INCHES)	DIM. B (INCHES)	MAX INTERRUPTING RATING RMS (ASYM)*	FIGURE NUMBER
15.5 MAX. KV	10E1C15.5	10E	15"	18.875"	80,000	4
	15E1C15.5	15E	15"	18.875"	80,000	4
	20E1C15.5	20E	15"	18.875"	80,000	4
	25E1C15.5	25E	15"	18.875"	80,000	4
	30E1C15.5	30E	15"	18.875"	80,000	4
	40E1C15.5	40E	15"	18.875"	80,000	4
	50E1C15.5	50E	15"	18.875"	80,000	4
	65E1C15.5	65E	15"	18.875"	80,000	4
	80E1C15.5	80E	15"	18.875"	80,000	4
	100E1C15.5	100E	15"	18.875"	80,000	4
	65E2C15.5	65E	15"	18.875"	80,000	5
	80E2C15.5	80E	15"	18.875"	80,000	5
	100E2C15.5	100E	15"	18.875"	80,000	5
	125E2C15.5	125E	15"	18.875"	80,000	5
	150E2C15.5	150E	15"	18.875"	80,000	5
	175E2C15.5	175E	15"	18.875"	80,000	5
	200E2C15.5	200E	15"	18.875"	80,000	5
	200E3C15.5	200E	15"	18.875"	80,000	6
250E3C15.5	250E	15"	18.875"	80,000	6	
300E3C15.5	300E	15"	18.875"	80,000	6	

* RMS Asymmetrical amperes = RMS Symmetrical amperes x 1.6

E-RATED MEDIUM VOLTAGE FUSES

3
Medium Voltage Fuses

E-RATED	ORDERING/CATALOG NUMBER	SIZE	DIM. A (INCHES)	DIM. B (INCHES)	MAX INTERRUPTING RATING RMS (ASYM)*	FIGURE NUMBER
15.5 MAX. KV	15GSE65E	65E	18"	21 ⁷ / ₈ "	60,000	4
	15GSE80E	80E	18"	21 ⁷ / ₈ "	60,000	4
	15GSE100E	100E	18"	21 ⁷ / ₈ "	60,000	4
	15GSE2125E	125E	18"	21 ⁷ / ₈ "	60,000	5
	15GSE2150E	150E	18"	21 ⁷ / ₈ "	60,000	5
	15GSE2175E	175E	18"	21 ⁷ / ₈ "	60,000	5
	15GSE2200E	200E	18"	21 ⁷ / ₈ "	60,000	5

E-RATED	ORDERING/CATALOG NUMBER	SIZE	DIM. A (INCHES)	DIM. B (INCHES)	MAX INTERRUPTING RATING RMS (ASYM)*	FIGURE NUMBER
15.5 MAX. KV	15NLE10E	10E	20"	23 ⁷ / ₈ "	60,000	4
	15NLE15E	15E	20"	23 ⁷ / ₈ "	60,000	4
	15NLE20E	20E	20"	23 ⁷ / ₈ "	60,000	4
	15NLE25E	25E	20"	23 ⁷ / ₈ "	60,000	4
	15NLE30E	30E	20"	23 ⁷ / ₈ "	60,000	4
	15NLE40E	40E	20"	23 ⁷ / ₈ "	60,000	4
	15NLE50E	50E	20"	23 ⁷ / ₈ "	60,000	4
	15NLE65E	65E	20"	23 ⁷ / ₈ "	60,000	4
	15NLE80E	80E	20"	23 ⁷ / ₈ "	60,000	4
	15NLE100E	100E	20"	23 ⁷ / ₈ "	60,000	4
	15NLE280E	80E	20"	23 ⁷ / ₈ "	60,000	5
	15NLE2100E	100E	20"	23 ⁷ / ₈ "	60,000	5
	15NLE2125E	125E	20"	23 ⁷ / ₈ "	60,000	5
	15NLE2150E	150E	20"	23 ⁷ / ₈ "	60,000	5
	15NLE2175E	175E	20"	23 ⁷ / ₈ "	60,000	5
	15NLE2200E	200E	20"	23 ⁷ / ₈ "	60,000	5
	15NLE3150E	150E	20"	23 ⁷ / ₈ "	60,000	6
15NLE3175E	175E	20"	23 ⁷ / ₈ "	60,000	6	
15NLE3250E	250E	20"	23 ⁷ / ₈ "	60,000	6	
15NLE3300E	300E	20"	23 ⁷ / ₈ "	60,000	6	

E-RATED	ORDERING/CATALOG NUMBER	SIZE	DIM. A (INCHES)	DIM. B (INCHES)	MAX INTERRUPTING RATING RMS (ASYM)*	FIGURE NUMBER
25.8 MAX. KV	15E1C25.8	15E	21"	24 ⁷ / ₈ "	40,000	4
	20E1C25.8	20E	21"	24 ⁷ / ₈ "	40,000	4
	25E1C25.8	25E	21"	24 ⁷ / ₈ "	40,000	4
	30E1C25.8	30E	21"	24 ⁷ / ₈ "	40,000	4
	40E1C25.8	40E	21"	24 ⁷ / ₈ "	40,000	4
	50E1C25.8	50E	21"	24 ⁷ / ₈ "	40,000	4
	65E2C25.8	65E	21"	24 ⁷ / ₈ "	40,000	5
	80E2C25.8	80E	21"	24 ⁷ / ₈ "	40,000	5
	100E2C25.8	100E	21"	24 ⁷ / ₈ "	40,000	5

E-RATED	ORDERING/CATALOG NUMBER	SIZE	DIM. A (INCHES)	DIM. B (INCHES)	MAX INTERRUPTING RATING RMS (ASYM)*	FIGURE NUMBER
38 MAX. KV	3E1C38.0	3E	27"	30 ⁷ / ₈ "	20,000	4
	7E1C38.0	7E	27"	30 ⁷ / ₈ "	20,000	4
	10E1C38.0	10E	27"	30 ⁷ / ₈ "	20,000	4
	15E1C38.0	15E	27"	30 ⁷ / ₈ "	20,000	4
	20E1C38.0	20E	27"	30 ⁷ / ₈ "	20,000	4
	25E1C38.0	25E	27"	30 ⁷ / ₈ "	20,000	4
	30E1C38.0	30E	27"	30 ⁷ / ₈ "	20,000	4
	40E1C38.0	40E	27"	30 ⁷ / ₈ "	20,000	4
	50E2C38.0	50E	27"	30 ⁷ / ₈ "	20,000	5
	65E2C38.0	65E	27"	30 ⁷ / ₈ "	20,000	5
80E2C38.0	80E	27"	30 ⁷ / ₈ "	20,000	5	

* RMS Asymmetrical amperes = RMS Symmetrical amperes x 1.6

E-RATED MEDIUM VOLTAGE FUSES

Clip Lock Design

The clip lock type designs ensures a positive contact between the fuse and the connection cam. The fuse's clip lock tab slides in between the clip casting and the cam to prevent the fuse from slipping or blowing out of the holder. This positive contact improves heat dissipation and allows fuses to run cooler.

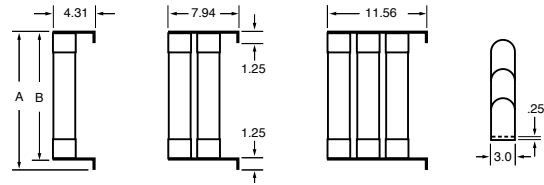

Figure 7

Figure 8

Figure 9

Dimensions in inches

3

Medium Voltage Fuses

E-RATED	ORDERING/CATALOG NUMBER	SIZE	DIM. A (INCHES)	DIM. B (INCHES)	MAX INTERRUPTING RATING RMS (ASYM)*	FIGURE NUMBER
5.5 MAX. KV CLIP LOCK	10E1CL5.5	10E	16.38"	15.13"	80,000	7
	15E1CL5.5	15E	16.38"	15.13"	80,000	7
	20E1CL5.5	20E	16.38"	15.13"	80,000	7
	25E1CL5.5	25E	16.38"	15.13"	80,000	7
	30E1CL5.5	30E	16.38"	15.13"	80,000	7
	40E1CL5.5	40E	16.38"	15.13"	80,000	7
	50E1CL5.5	50E	16.38"	15.13"	80,000	7
	65E1CL5.5	65E	16.38"	15.13"	80,000	7
	80E1CL5.5	80E	16.38"	15.13"	80,000	7
	100E1CL5.5	100E	16.38"	15.13"	80,000	7
	125E1CL5.5	125E	16.38"	15.13"	80,000	7
	150E1CL5.5	150E	16.38"	15.13"	80,000	7
	225E2CL5.5	225E	17.38"	16.13"	80,000	8
	250E2CL5.5	250E	17.38"	16.13"	80,000	8
	300E2CL5.5	300E	17.38"	16.13"	80,000	8
	350E2CL5.5	350E	17.38"	16.13"	80,000	8
	400E2CL5.5	400E	17.38"	16.13"	80,000	8
	450E2CL5.5	450E	17.38"	16.13"	80,000	8
500E3CL5.5	500E	17.38"	16.13"	80,000	9	
550E3CL5.5	550E	17.38"	16.13"	80,000	9	
600E3CL5.5	600E	17.38"	16.13"	80,000	9	
E-RATED	ORDERING/CATALOG NUMBER	SIZE	DIM. A (INCHES)	DIM. B (INCHES)	MAX INTERRUPTING RATING RMS (ASYM)*	FIGURE NUMBER
8.25 MAX. KV CLIP LOCK	10E1CL8.25	10E	17.38"	16.13"	80,000	7
	15E1CL8.25	15E	17.38"	16.13"	80,000	7
	20E1CL8.25	20E	17.38"	16.13"	80,000	7
	25E1CL8.25	25E	17.38"	16.13"	80,000	7
	30E1CL8.25	30E	17.38"	16.13"	80,000	7
	40E1CL8.25	40E	17.38"	16.13"	80,000	7
	50E1CL8.25	50E	17.38"	16.13"	80,000	7
	65E1CL8.25	65E	17.38"	16.13"	80,000	7
	80E1CL8.25	80E	17.38"	16.13"	80,000	7
	100E1CL8.25	100E	17.38"	16.13"	80,000	7
	125E2CL8.25	125E	17.38"	16.13"	80,000	8
	150E2CL8.25	150E	17.38"	16.13"	80,000	8
	175E2CL8.25	175E	17.38"	16.13"	80,000	8
	200E2CL8.25	200E	17.38"	16.13"	80,000	8
	225E2CL8.25	225E	17.38"	16.13"	80,000	8
	250E2CL8.25	250E	17.38"	16.13"	80,000	8
	300E2CL8.25	300E	17.38"	16.13"	80,000	8
	350E3CL8.25	350E	17.38"	16.13"	80,000	9
E-RATED	ORDERING/CATALOG NUMBER	SIZE	DIM. A (INCHES)	DIM. B (INCHES)	MAX INTERRUPTING RATING RMS (ASYM)*	FIGURE NUMBER
15.5 MAX. KV CLIP LOCK	10E1CL15.5	10E	19.8"	18.1"	60,000	7
	15E1CL15.5	15E	19.8"	18.1"	60,000	7
	20E1CL15.5	20E	19.8"	18.1"	60,000	7
	25E1CL15.5	25E	19.8"	18.1"	60,000	7
	30E1CL15.5	30E	19.8"	18.1"	60,000	7
	40E1CL15.5	40E	19.8"	18.1"	60,000	7
	50E1CL15.5	50E	19.8"	18.1"	60,000	7
	65E1CL15.5	65E	22.81"	21.13"	60,000	7
	80E1CL15.5	80E	22.81"	21.13"	60,000	7
	100E1CL15.5	100E	22.81"	21.13"	60,000	7
	125E2CL15.5	125E	22.81"	21.13"	60,000	8
	150E2CL15.5	150E	22.81"	21.13"	60,000	8
	175E2CL15.5	175E	22.81"	21.13"	60,000	8
	200E2CL15.5	200E	22.81"	21.13"	60,000	8
	150E3CL15.5	150E	22.81"	21.13"	60,000	9
	200E3CL15.5	200E	22.81"	21.13"	60,000	9
	250E3CL15.5	250E	22.81"	21.13"	60,000	9
	300E3CL15.5	300E	22.81"	21.13"	60,000	9

* RMS Asymmetrical amperes = RMS Symmetrical amperes x 1.6

E-RATED POTENTIAL TRANSFORMER FUSES

Description

Potential Transformer (PT) fuses are current-limiting fuses with high interrupting ratings designed for the protection of potential transformers.

Application Note

When applying fuses for the protection of transformers, the magnetizing current in-rush must be considered. The characteristics of the in-rush, which can be matched with a fuse time-current curve, should be available from the transformer manufacturer.

Characteristics

Voltage Ratings 625 Vac – 25,800 Vac
Current Range ½E – 10E

Dimensions

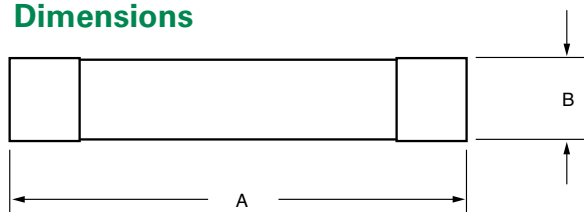

E-RATED	ORDERING/CATALOG NUMBER	SIZE	LENGTH DIM. A (INCHES)	DIAMETER DIM. B (INCHES)	MAX INTERRUPTING RATING RMS (ASYM)*
625 VOLT	3E4PT.6	3E	4.6"	0.8125"	37,500
	5E4PT.6	5E	4.6"	0.8125"	37,500
	7E4PT.6	7E	4.6"	0.8125"	37,500
	10E4PT.6	10E	4.6"	0.8125"	37,500
2.75 MAX. KV	500E4PT2.4	½E	4.6"	0.8125"	37,500
	1E4PT2.4	1E	4.6"	0.8125"	37,500
	2E4PT2.4	2E	4.6"	0.8125"	37,500
2.75 MAX. KV	1E6PT2.75	1E	7.4"	1.5625"	37,500
	2E6PT2.75	2E	7.4"	1.5625"	37,500
	3E6PT2.75	3E	7.4"	1.5625"	37,500
	1E8PT2.75	1E	9.5"	1.5625"	37,500
	2E8PT2.75	2E	9.5"	1.5625"	37,500
	3E8PT2.75	3E	9.5"	1.5625"	37,500
4.8 MAX. KV	1E5PT4.8	1E	5.6"	0.8125"	50,000
	2E5PT4.8	2E	5.6"	0.8125"	50,000
5.5 MAX. KV	500E6PT5.5	½E	7.4"	1.5625"	50,000
	1E6PT5.5	1E	7.4"	1.5625"	50,000
	2E6PT5.5	2E	7.4"	1.5625"	50,000
	3E6PT5.5	3E	7.4"	1.5625"	50,000
	5E6PT5.5	5E	7.4"	1.5625"	50,000
	500E8PT5.5	½E	9.5"	1.5625"	50,000
	1E8PT5.5	1E	9.5"	1.5625"	50,000
	2E8PT5.5	2E	9.5"	1.5625"	50,000
	3E8PT5.5	3E	9.5"	1.5625"	50,000
	5E8PT5.5	5E	9.5"	1.5625"	50,000
8.25 MAX. KV	10E8PT5.5	10E	9.5"	1.5625"	50,000
	500E8PT8.25	½E	9.5"	1.5625"	50,000
	1E8PT8.25	1E	9.5"	1.5625"	50,000
	2E8PT8.25	2E	9.5"	1.5625"	50,000
15.5 MAX. KV	3E8PT8.25	3	9.5"	1.5625"	50,000
	500E11PT15.5	½E	12.8"	1.5625"	35,000
	1E11PT15.5	1E	12.8"	1.5625"	35,000
	2E11PT15.5	2E	12.8"	1.5625"	35,000
	3E11PT15.5	3E	12.8"	1.5625"	35,000
25.8 MAX. KV	3E16PT15.5	3E	17.5"	1.5625"	35,000
	5E16PT15.5	5E	17.5"	1.5625"	35,000
	500E16PT25.5	½E	17.5"	1.5625"	32,000
	1E16PT25.5	1E	17.5"	1.5625"	32,000

* RMS Asymmetrical amperes = RMS Symmetrical amperes x 1.6

LIVE PARTS



Description

Live parts are available for mounting E, R, and PT single, double, and triple barrel fuses. Mounting clips are available for ferrule type and clip lock style fuses. All clips are sold in pairs.

Part Number 700-156 Ordering Number 0700156.Z

For use with 1⁹/₁₆" (1.5625") to 1⁵/₈" (1.625") diameter PT fuses.

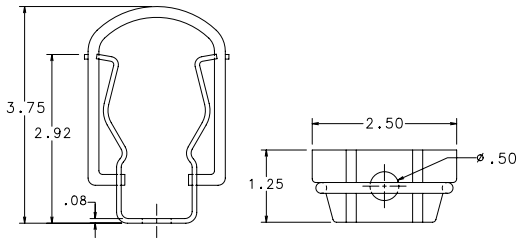

Dimensions in inches

Part Number 700-300 Ordering Number 0700300.Z

For use with 3" diameter fuses.

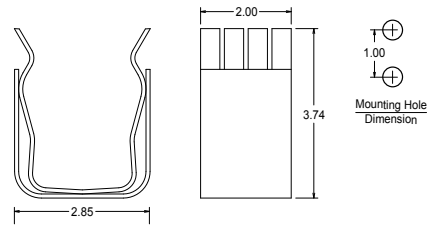

Part Number 700-500 Ordering Number 0700500.Z

For use with all 1³/₁₆" (.8125") diameter PT fuses

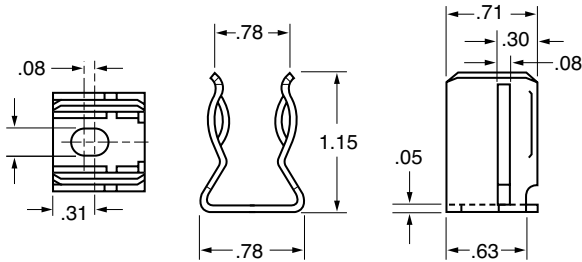

Dimensions in inches

Part Number 700-530 Ordering Number 0700530.Z

For use with all 3" diameter fuses.

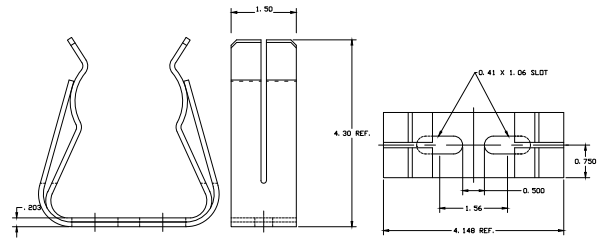

Part Number 700-520-CL Ordering Number 0700520.ZXCL

Clip Lock Design

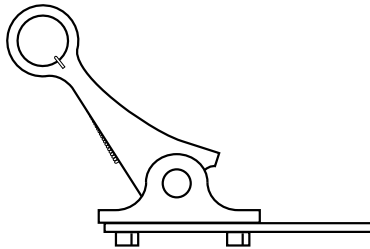

Dimensions for reference only.

Mounting Details for Clip Lock

CATALOG NUMBER	DIMENSION A (INCHES)
10E1CL5.5 thru 150E1CL5.5	12.88
225E2CL5.5 thru 600E3CL5.5	13.88
10E1CL8.25 thru 350E3CL8.25	13.88
10E1CL15.5 thru 50E1CL15.5	16.25
65E1CL15.5 thru 300E3CL15.5	19.25

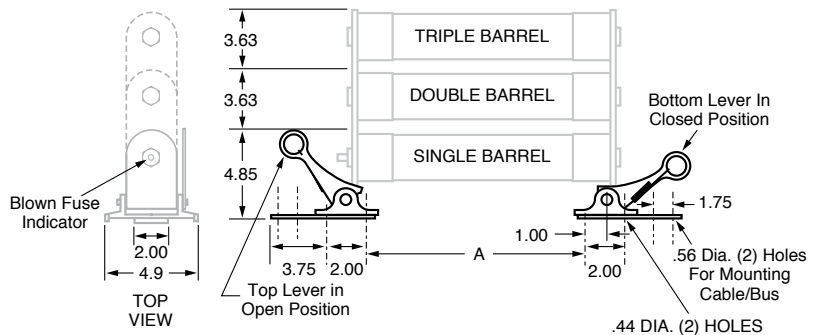

Section Overview

Rely on Littelfuse for short circuit protection of telecommunications circuits and sensitive DC power distribution circuits.



TELECOM PRODUCTS

Table of Contents

L17T Series Telecommunications Power Fuse.....	50
TLN Series Telecommunications Power Fuse.....	51
TLS Series Telecommunications Power Fuse	52
Alarm Indicating Fuses.....	54
LTFD101 Telecommunication Disconnect Switch	55

L17T SERIES TELECOM POWER FUSE

170 Vdc • Current-Limiting • 70-1200 A



Ordering Information

AMPERE RATINGS						
70	125	200	300	450	800	1100
90	150	225	350	500	900	1200
100	175	250	400	600	1000	—

SERIES	VOLTAGE	AMPERAGE	CATALOG NUMBER	ORDERING NUMBER
L17T	170	1200	L17T 1200	L17T1200V

Dimensions Inches (mm)

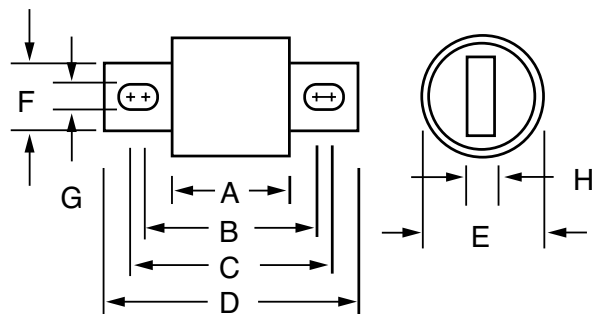

AMPERE RATING	DIMENSIONS INCHES (mm)							
	A	B	C	D	E	F	G	H
70 – 250	1 ⁵ / ₃₂ (29.4)	1 ¹ / ₈ (47.6)	2 ³ / ₁₆ (55.6)	2 ²¹ / ₃₂ (67.5)	1 (25.4)	7 ⁷ / ₈ (22.2)	0.327 (8.3)	3 ³ / ₁₆ (4.8)
300 – 800	1 ¹ / ₄ (31.8)	1 ¹⁵ / ₁₆ (49.2)	2 ⁹ / ₁₆ (65.1)	3 ¹ / ₂ (88.9)	1 ¹ / ₂ (38.1)	1 (25.4)	1 ¹³ / ₃₂ (10.3)	1 ¹ / ₄ (6.35)
900 – 1200	1 ¹¹ / ₃₂ (34.0)	—	—	4 ¹ / ₁₆ (103.1)	2 (50.8)	1 ¹ / ₂ (38.1)	—	1 ¹ / ₄ (6.35)

Description

Specifically designed for short-circuit protection of telecommunications circuits, the Littelfuse L17T series fuses provide reliable protection of sensitive DC power distribution systems. Constructed with silver plated elements for low I²t and peak let-through, these advanced fuses virtually eliminate equipment damage due to surges and spikes. The L17T series fuse unique element geometry also provides cooler running temperatures, helping to minimize heat within enclosures.

Features

- Low I²t
- Extremely current-limiting
- Low operating temperature
- 170 Vdc rating

Specifications

Voltage Rating	170 Vdc
Interrupting Rating	100 kA
Ampere Range	70 – 1200 A
Approvals	UL Recognized (File: E71611) CSA Recognized (File: LR29862)

Web Resources

For additional information, visit:
littelfuse.com/l17t

TLN SERIES TELECOM POWER FUSE

170 Vdc • Current-Limiting • 1-600 A



Specifications

Voltage Rating	170 Vdc
Interrupting Rating	100 kA
Ampere Range	1 – 600 A
Approvals	UL Recognized (File: E71611)

Ordering Information

AMPERE RATINGS						
1	15	40	80	150	300	600
3	20	45	90	175	350	—
5	25	50	100	200	400	—
6	30	60	110	225	450	—
10	35	70	125	250	500	—

SERIES	VOLTAGE	AMP	CATALOG NUMBER	ORDERING NUMBER
TLN	170VDC	6	TLN006	OTLN006.T

Replaces competitors' TPN and TGN Series.

Description

The TLN Series fuses are specifically designed for the protection of telecommunications DC power distribution circuits.

Features

- 170 Vdc rating
- Fast-acting and current-limiting
- 1 to 600 amperes rating
- Dimensionally similar to 250 V Class R fuses

Dimensions Inches (mm)

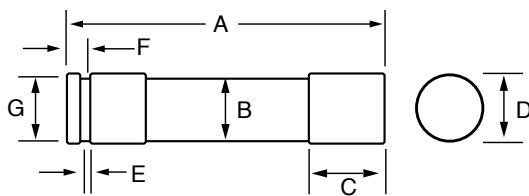

FIG. 1

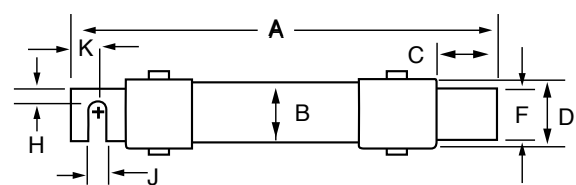

FIG. 2

AMPERES	FIGURE NUMBER	DIMENSIONS INCHES (mm)									
		A	B	C	D	E	F	G	H	J	K
1 – 30	1	2 (50.8)	1/2 (12.7)	1/2 (12.7)	9/16 (14.3)	5/64 (2.0)	5/32 (4.0)	3/8 (9.5)	—	—	—
35 – 60	1	3 (76.2)	3/4 (19.1)	5/8 (15.9)	13/16 (20.6)	3/32 (2.4)	3/16 (4.8)	5/8 (15.9)	—	—	—
70 – 100	2	5 7/8 (149.2)	1 (25.4)	1 1/16 (27.0)	1 1/16 (27.0)	1/8 (3.2)	3/4 (19.1)	1 1/4 (31.6)	1/4 (6.4)	9/32 (7.1)	1/2 (12.7)
110 – 200	2	7 1/8 (181.0)	1 1/2 (38.1)	1 15/32 (37.3)	1 19/32 (40.5)	3/16 (4.8)	1 1/8 (28.6)	1 27/32 (46.8)	7/16 (11.1)	9/32 (7.1)	1 1/16 (17.5)
225 – 400	2	8 5/8 (219.1)	2 (50.8)	1 15/16 (49.2)	2 3/32 (53.2)	1/4 (6.4)	1 5/8 (41.3)	2 11/32 (59.5)	5/8 (15.9)	13/32 (10.3)	1 5/16 (23.8)
450 – 600	2	10 3/8 (263.5)	2 1/2 (63.5)	2 3/8 (60.3)	2 19/32 (65.9)	1/4 (6.4)	2 (50.8)	2 27/32 (72.2)	3/4 (19.1)	1 7/32 (13.5)	1 1/8 (28.6)

TLS SERIES TELECOM POWER FUSE

170 Vdc • Current-Limiting • 1-125 A



4

Telecom Products

Description

Littelfuse TLS Series fuses are designed specifically for the protection of telecommunications equipment. TLS fuses have been engineered to operate up to 170 Vdc to provide current-limiting short-circuit protection for cables and components found in the DC power distribution circuits of telecommunications systems. The compact design and multiple mounting configurations of the TLS series allow it to be used in a variety of applications.

Features

- 170 Vdc rating
- Current-limiting
- 1 to 125 amperes rating
- Multiple mounting configurations — Cartridge, Vertical, Leaded, Bolt-In, or Solder type. See dimensions on page 2 for mounting style details.
- RoHS Compliant

Web Resources

For additional information, visit:
littelfuse.com/tls

Recommended Fuse Holders

LFTD series disconnect switches

LFT30060 (for TLS series cartridge style fuse)..... 100

Contact factory for more information.

Specifications

Voltage Rating	170 Vdc
Ampere Range	1 – 125 A
Interrupting Rating	100 kA
Approvals	UL Recognized (File: E71611)
Construction	Body: Glass melamine Caps: Silver-plated brass
Environmental	RoHS Compliant, Lead (Pb) Free

Ordering Information

AMPERE RATINGS					
1	6	25	50	90	
2	10	30	60	100	
3	15	35	70	110*	
5	20	40	80	125*	

*Available in standard cartridge only.

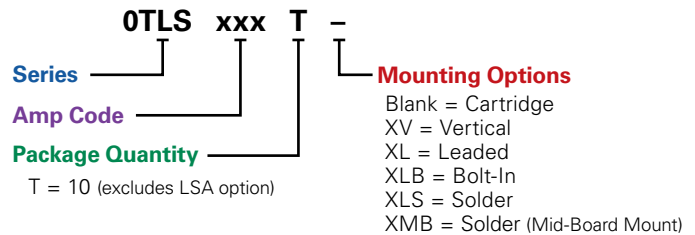

SERIES	AMP	MOUNTING METHOD	MOUNTING SUFFIX	CATALOG NUMBER	ORDERING NUMBER
TLS	6	Cartridge	—	TLS006	OTLS006.T
TLS	15	Vertical	V	TLS015V	OTLS015.TXV
TLS	35	Leaded	L	TLS035L	OTLS035.TXL
TLS	50	Bolt-In	LB	TLS050LB	OTLS050.TXLB
TLS	80	Solder	LS	TLS080LS	OTLS080.TXLS
TLS	100	Solder	MB	TLS100MB	OTLS100.TXMB

TLS SERIES TELECOM POWER FUSE

Dimensions Inches (mm)

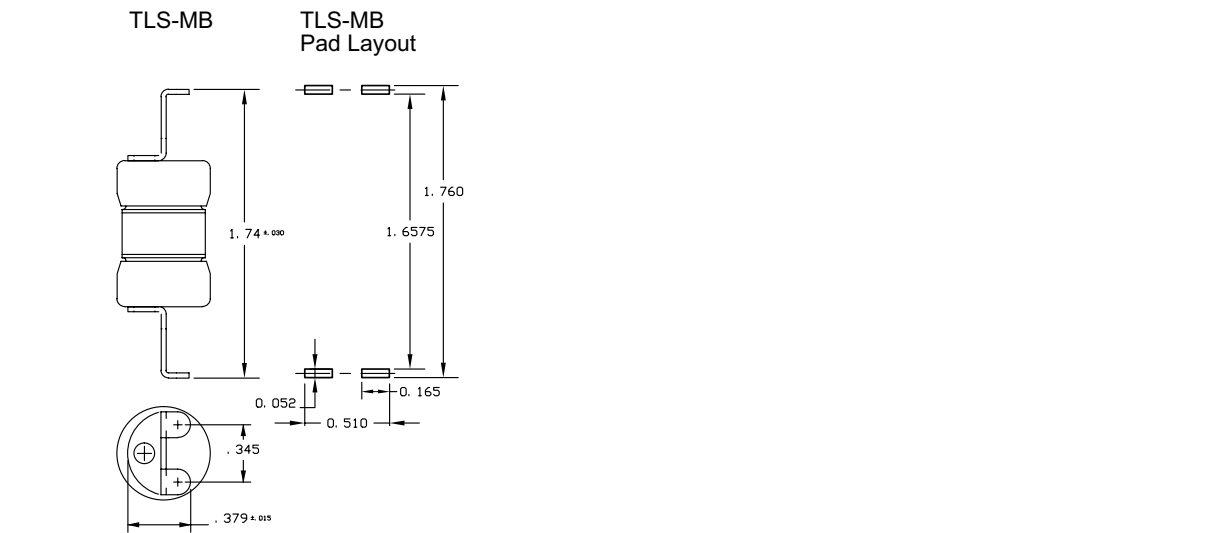
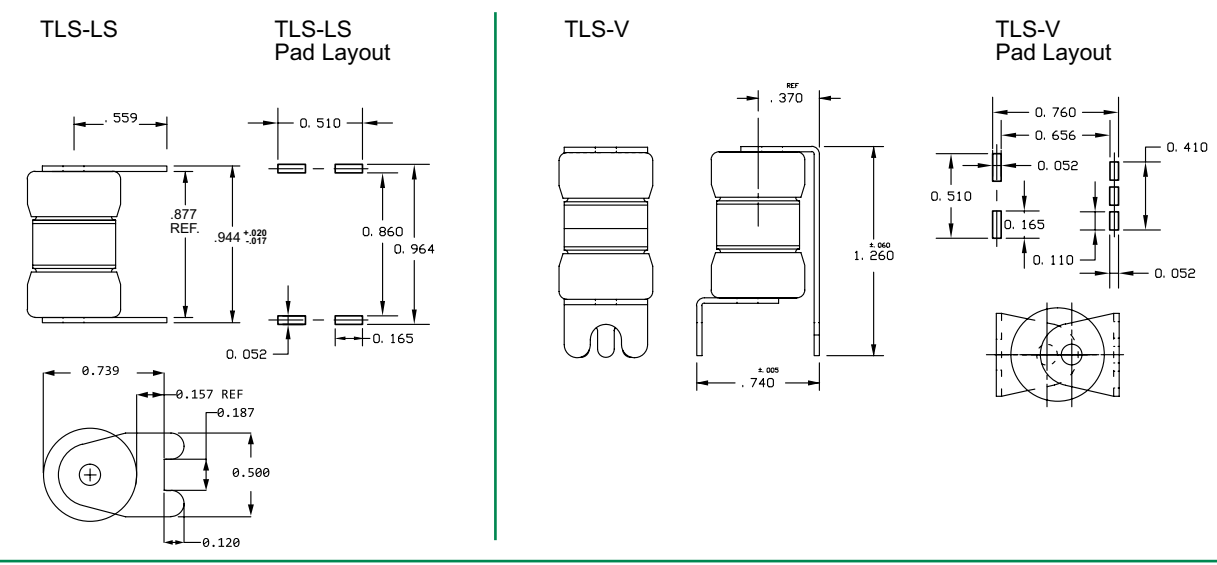
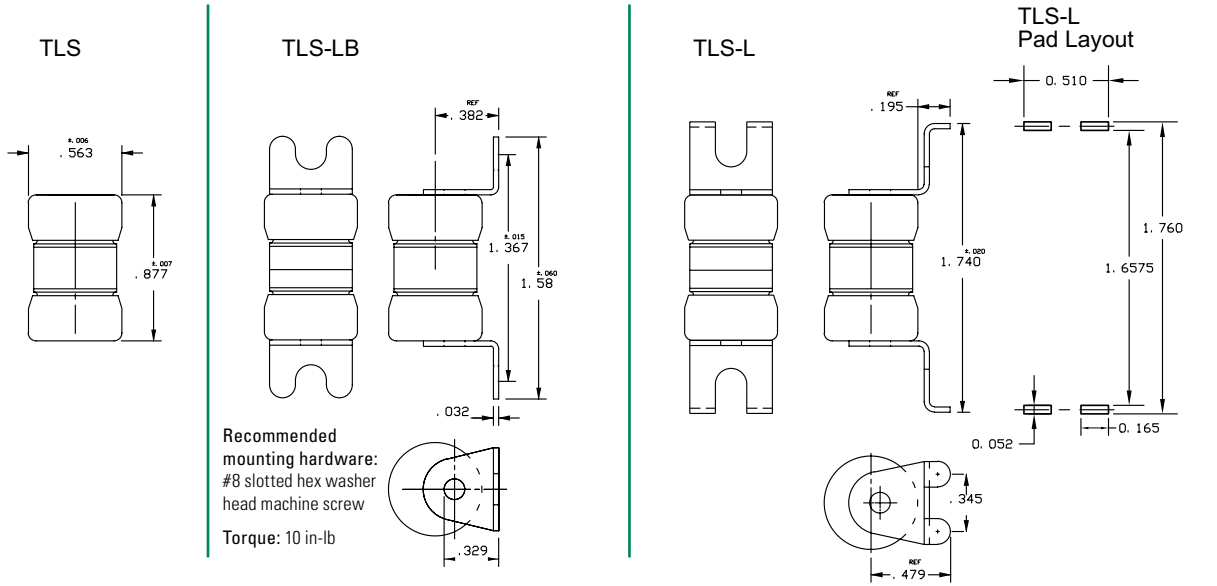

481 SERIES ALARM INDICATING FUSES

Alarm Indicating Fuses



481 Series Alarm Indicating Fuses

Description

481 Series alarm indicating fuses are designed to reduce down time by immediately pinpointing the blown (open) circuit while triggering an LED or audio alarm. This item requires 482 Series mating fuse holder.

All ranges of 481 Series fuses are available as our original design, and the 2-20 amp range is now available as a RoHS compliant option (use the "P" designator when ordering). See the part numbering section of the datasheet for related ordering instructions.

Specifications

Voltage Rating Approvals

125 Vac/dc
UL Recognized (File: E71611)
CSA Recognized (File: LR29862)



Ordering Information

AMPERE RATINGS						
¹⁸ / ₁₀₀	³ / ₈	³ / ₄	1 1/2	3	5	12
1/5	1/2	1	2	3 1/2	7 1/2	15
1/4	⁶⁵ / ₁₀₀	1 1/3	2 1/2	4	10	20

SERIES	VOLTAGE	AMP	CATALOG NUMBER	ORDERING NUMBER
481	125 ac/dc	2	481002L	0481002.VXL

Note: For 481 Dummy fuse, order 481000.

Recommended Fuse Holders

482 Series, see website: littelfuse.com/482
Available 1-20 pole with PCB or panel mounting.
To order with protective lens add suffix XL.

Web Resources

For additional information, visit: littelfuse.com/481

LTFD 101 SERIES TELECOM DISCONNECT SWITCH

80 Vdc • 1-125 A



Description

Littelfuse compact LTFD 101 fuse holders for TLS fuses are designed for quick installation into telecom equipment panels. Their modular design fits into spaces originally designed for circuit breakers and can be front panel mounted or rear mounted using bullet connectors. The innovative new pull-out design eliminates the need for tools to replace fuses and includes an alarm signaling circuit to identify the blown fuse.

Features

- Extremely compact
- Quick mounting
- Replaces circuit breakers
- Includes alarm signaling circuit

Dimensions Inches (mm)

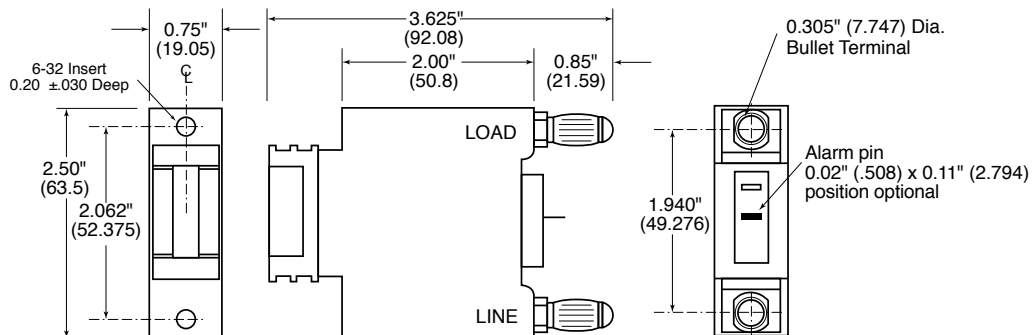

Dimensions for reference only. For additional options and dimensions, contact the factory.

Specifications

Voltage Rating	80 Vdc
Ampere Range	1–125 A
Approvals	UL Recognized (File: E122674)

Recommended Fuses

Littelfuse TLS Series fuses 52

Ordering Information

SERIES	AMPERAGE	CATALOG NUMBER	ORDERING NUMBER	TERMINAL TYPE
LTFD	125 A MAX	LTFD101-1	LTFD0101ZX1	BULLET
LTFD	125 A MAX	LTFD101-2	LTFD0101ZX2	SCREW
LTFD	125 A MAX	LTFD101-3	LTFD0101ZX3	STUD
LTFD	70 A MAX	LTFD101-4	LTFD0101ZX4	CLIP

Web Resources

For additional information, visit:
littelfuse.com/lbfd101

Section Overview

Whether you are protecting solar equipment or finding a replacement fuse for an aging HVAC unit, Littelfuse carries the breadth of fuses to meet your needs. Our “special purpose” fuse section includes application-specific products to meet all of your application needs.



SPECIAL PURPOSE FUSES

Table of Contents



POWR-GARD® Circuit Protection

Littelfuse engineering is constantly developing new products to meet the needs of the photovoltaic industry. For the latest information on the growing POWR-GARD Product portfolio, visit:

littelfuse.com/solar

Solar Rated Products Overview.....	57
1500 Vdc Solar Rated Fuses.....	58
1000 Vdc Solar Rated Fuses.....	61
Forklift / Stud Mounted Fuses.....	64
Plug Fuses.....	65
MEGA® Bolt-Down Fuses.....	65
In-Line Fuses And Holder.....	66
Cable Limiters.....	67
Cylindrical Fuses.....	68
OEM Custom Products.....	69

SOLAR RATED PRODUCTS BY APPLICATION

Solar Applications

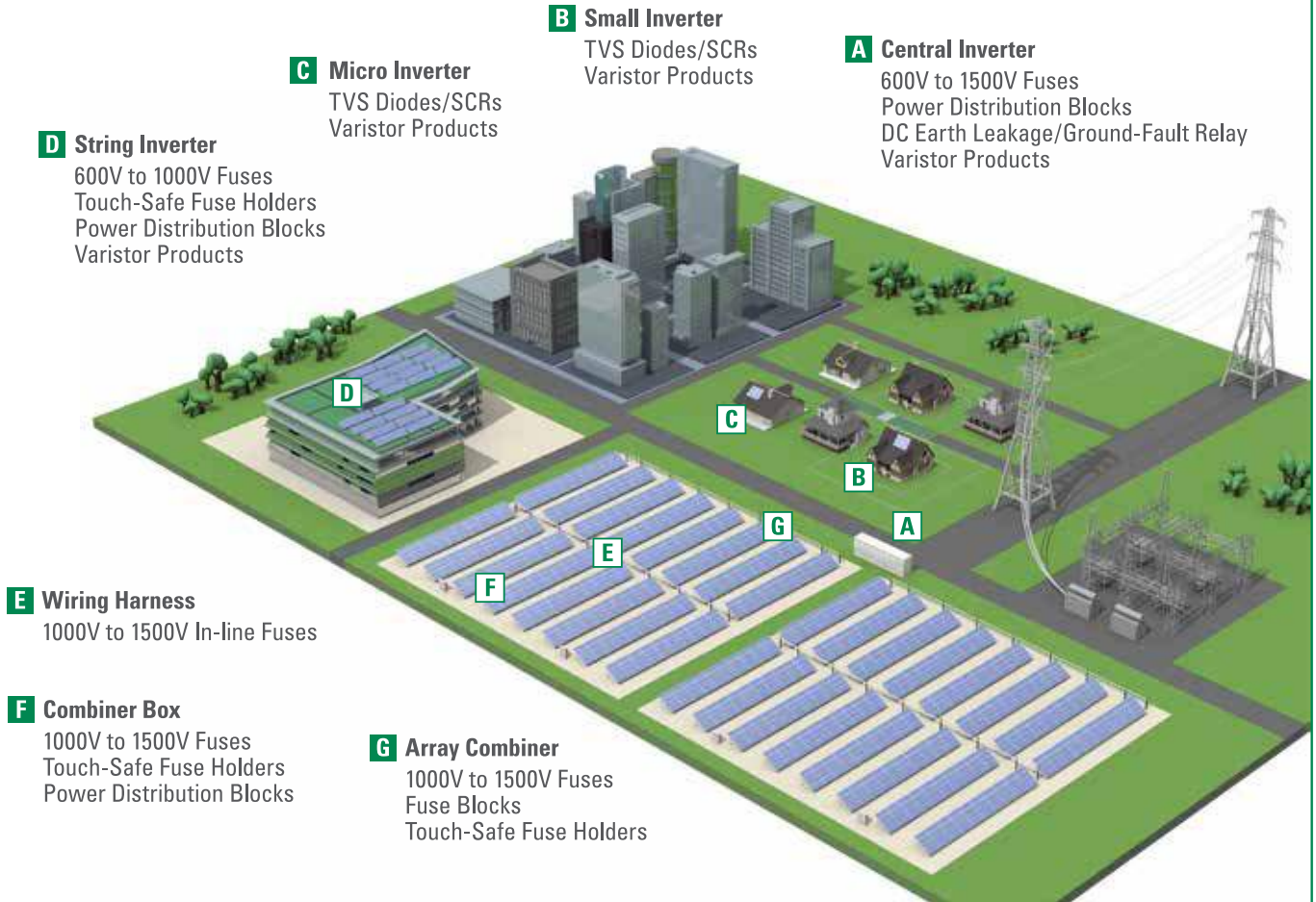

5
Solar Fuses

With over 16.5 million devices installed in photovoltaic power systems, Littelfuse understands the global challenges of the solar market. Littelfuse offers numerous circuit-protection products that are uniquely suited to protect the equipment and systems subject to the harsh environments of standard photovoltaic installations.

SPXV SERIES SOLAR FUSE

1500 Vdc • 6 – 30 A



Description

The Littelfuse SPXV solar string fuse is designed specifically for 6-30 A 1500 Vdc applications.

Features/Benefits

- 10 x 85 mm package size
- UL 248-19 Listed
- Meets IEC 60269-6 electrical performance requirements
- Up to 50,000A interrupting rating

Applications

- Inverters
- Combiner boxes

Web Resources

Download technical resources at: littelfuse.com/spxv
For silver plated version: littelfuse.com/spxvs

Specifications

Voltage Rating	1500 Vdc
Amperage Rating	6, 8, 10, 12, 15, 20, 25, 30 A
Interrupting Rating	15 kA (UL 248-19) 50 kA (Self-Certified) 6A – 20A 30 kA (Self-Certified) 25A – 30A
Time Constant	≤ 1ms
Material	Body: Melamine Caps: Copper Alloy (Nickel Plated)
Approvals	UL 248-19 Listed (File: E339112)
Environmental	RoHS Compliant REACH
Country of Origin	Mexico

Part Numbering System

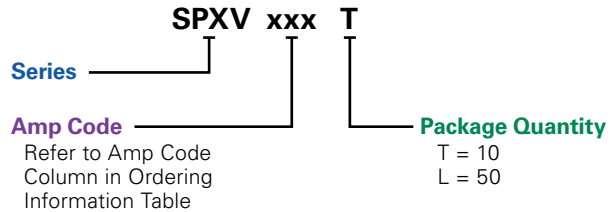

SERIES	AMP	PACKAGE QUANTITY	CATALOG NUMBER	ORDERING NUMBER
SPXV	6	10	SPXV006	SPXV006.T
SPXV	20	50	SPXV020	SPXV020.L

Dimensions mm (inches)

6 – 20 A

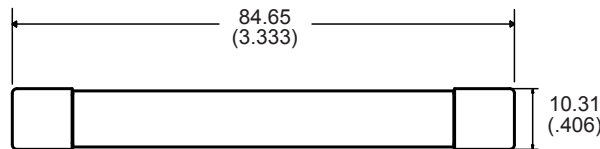

25 – 30 A

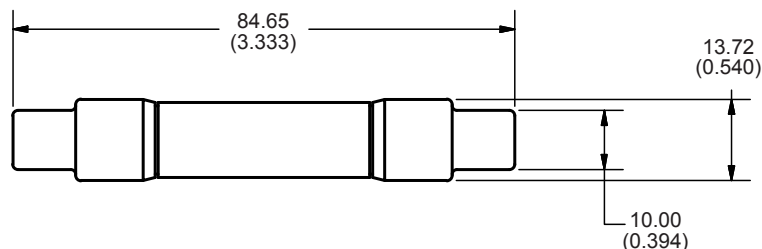

SPXI SERIES IN-LINE SOLAR FUSES

1500 Vdc • 2.5-30 A (Patent Pending)



Description

The Littelfuse SPXI solar fuse is designed to integrate into an in-line assembly within a wire harness. The fuse provides photovoltaic (PV) protection that meets UL 248-19 for photovoltaic applications. The SPXI can be electrically insulated by either overmolding or using heat-shrink.

Features/Benefits

- UL 248-19 Recognized
- Meets IEC 60269-6 electrical performance requirements
- 30,000 A interrupting rating
- No fuse holder required

Applications

- Photovoltaic wire harness

Recommended Crimping Tool

T&B Sta-Kon ERG4002

Dimensions mm (in)

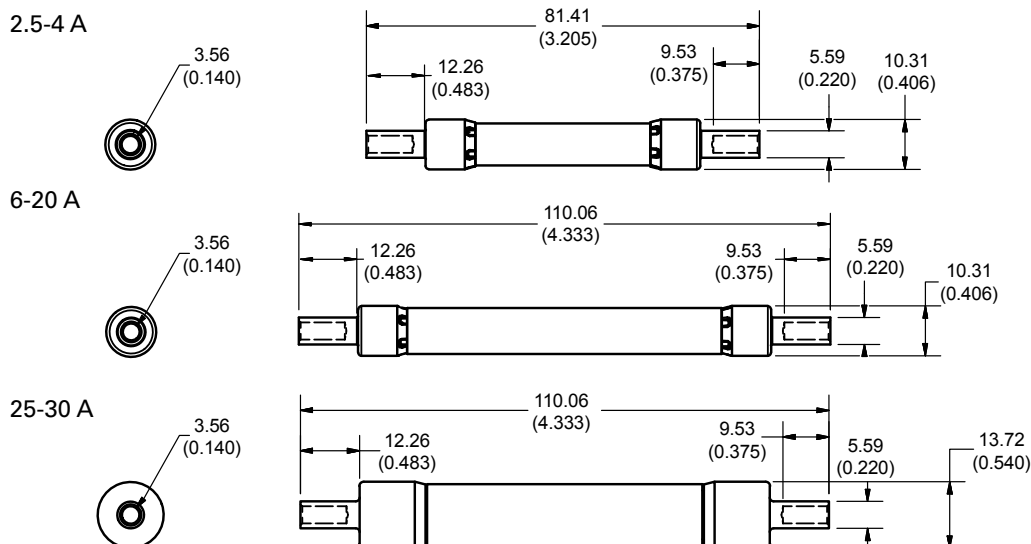

Specifications

Voltage Rating	1500 Vdc
Amperage Rating	2.5, 3.5, 4, 6, 8, 10, 12, 15, 20, 25, 30 A
Interrupting Ratings	15 kA (UL 248-19) 30 kA (Self-Certified)
Time Constant	≤ 1ms
Material	Body: Melamine Caps: Copper Alloy (Nickel Plated)
Approvals	UL 248-19 Recognized (File: E339112)
Environmental	RoHS Compliant REACH
Country of Origin	Mexico

Part Numbering System

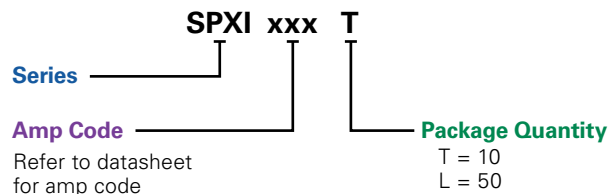

SERIES	AMP	PACKAGE QUANTITY	CATALOG NUMBER	ORDERING NUMBER
SPXI	3.5	10	SPXI03.5	SPXI03.5T
SPXI	4	10	SPXI004	SPXI004.T
SPXI	20	50	SPXI020	SPXI020.L

Web Resources

Download additional technical information and view the complete solar portfolio: littelfuse.com/spxi

SPNH SERIES SOLAR FUSE

1500 Vdc • 50-400 A • NH Style



Specifications

Voltage Rating	1500 Vdc
Amperage Rating	50, 63, 80, 100, 125, 160, 200, 250, 315, 350, 400
Interrupting Rating	15kA 30kA self-certified
Time Constant	≤ 2ms
Material	Body: Ceramic End Bells: Copper Alloy
Approvals	UL 248-19 Listed (File: E339112, Vol. 4) (50-200A) 250-400A pending IEC 60269-6
Environmental	RoHS Compliant

Part Numbering System

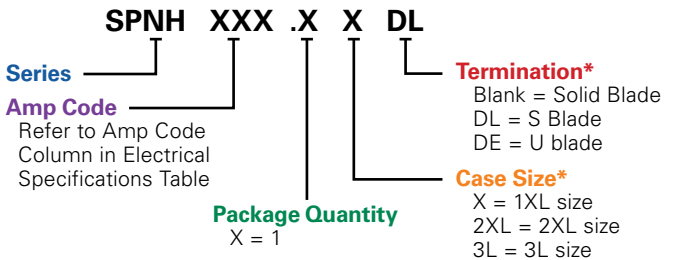

SERIES	AMP	PACKAGE QUANTITY	CATALOG NUMBER	ORDERING NUMBER
SPNH	50	1	SPNH050	SPNH050.X
SPNH	200	1	SPNH200	SPNH200.X

*Solid blade option for 1XL case size does not require a case or termination designator for the part number.

Recommended Accessories

1XL Case Size

Fuse Holder: LFNH152001CST
Fuse Terminal Covers: LFNH15200FBC

2XL Case Size

Fuse Holder: LFNH154001CST
Fuse Terminal Covers: LFNH15400FBC

3L Case Size

Fuse Holder: LFNH156301CST
Fuse Terminal Covers: LFNH15630FBC



Description

The SPNH series has been designed to meet the emerging circuit protection needs for 1500 volt photovoltaic systems. These fuses provide full range protection for all potential overcurrent conditions that exist in PV applications. Suitable for PV inverter protection and array combiner applications.

Features/Benefits

- Meets UL and IEC photovoltaic standards
- Compact NH XL Sizes
- Low Watt Loss Design
- 1500Vdc rating for emerging market needs
- Designed to protect against a full range of overcurrents

Applications

- Inverters
- Re-combiner boxes
- Array/Re-combiner application
- PV Inverter DC input protection

Web Resources

Download technical documents: Littelfuse.com/spnh



Look for this logo to indicate products that are used in solar applications. Visit our website Littelfuse.com/solar for the latest updates on approvals, certifications, and new products.

SPFI SERIES IN-LINE SOLAR FUSE

1000 Vdc • 2-30 A (Patent Pending)



Description

The Littelfuse SPFI solar fuse is designed to integrate into an in-line assembly within a wire harness. The fuse provides photovoltaic (PV) protection that meets UL 248-19 for photovoltaic applications. The SPFI can be electrically insulated by either overmolding or using heat-shrink.

Features/Benefits

- UL 248-19 Recognized
- Meets IEC 60269-6 electrical performance requirements
- 20,000 A Interrupting Rating
- No fuse holder required

Applications

- Photovoltaic wire harness

Specifications

Voltage Rating	1000 Vdc
Amperage Rating	2, 2.5, 3, 3.5, 4, 5, 6, 8, 10, 12, 15, 20, 25, 30 A
Interrupting Rating	20 kA
Time Constant	≤ 1ms
Material	Body: Melamine Caps: Copper Alloy (Nickel Plated)
Approvals	UL 248-19 Recognized (File: E339112)
Environmental	RoHS Compliant REACH
Country of Origin	Mexico

Part Numbering System

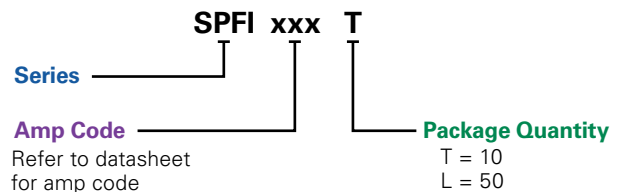

SERIES	AMP	PACKAGE QUANTITY	CATALOG NUMBER	ORDERING NUMBER
SPFI	2	10	SPFI002	SPFI002.T
SPFI	3.5	10	SPFI03.5	SPFI03.5T
SPFI	20	50	SPFI020	SPFI020.L

Web Resources

Downloadable CAD drawings and other technical information: littelfuse.com/spfi

Recommended Crimping Tool

T&B Sta-Kon ERG4002

Dimensions mm (in)

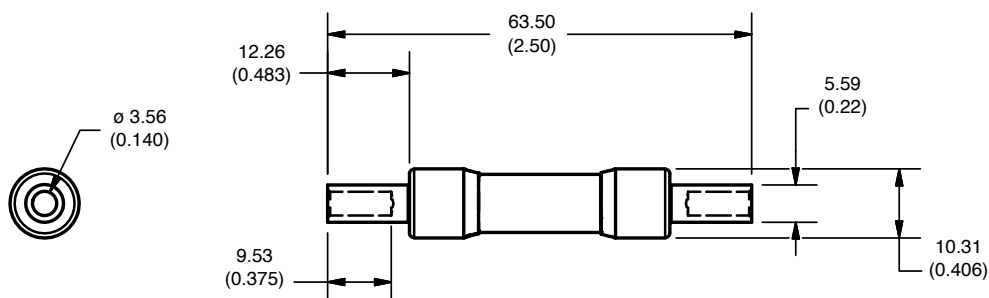

SPF SERIES SOLAR FUSES

1000 Vdc • 1-30 A



Description

The SPF Solar Protection Fuse series has been specifically designed for the protection of photovoltaic (PV) systems. This family of Midget style fuses (10 x 38 mm) can safely protect PV modules and conductors from reverse-current conditions.

As PV systems have grown in size, so have the corresponding voltage requirements. This increase in system voltage has typically been intended to minimize power loss associated with long conductor runs. Standard circuit protection devices are not designed to completely protect photovoltaic panels. However, the SPF series is UL Listed to safely interrupt faulted circuits up to this demanding voltage level.

Littelfuse offers 14 ampere ratings to match specific requirements in a variety of applications.

Features/Benefits

- Meets UL and IEC photovoltaic standards
- UL 248-19 Listed 1000 Vdc maximum
- 1-30 A ratings available
- 20,000 A Interrupting Rating - 1A - 20A
- 50,000 A Interrupting Rating - 25A - 30A
- Both PCB mount and dead-front holder options available

Applications

- Inverters
- Combiner boxes
- Battery charge controllers

Recommended Fuse Holders

LPHV 1000 Vdc POWR-Safe Series

Web Resources

Download technical documents: littelfuse.com/spf

Specifications

Voltage Rating	1000 VDC
Ampere Rating	1, 2, 3, 3.5, 4, 5, 6, 8, 10, 12, 15, 20, 25, 30
Max. Interrupting Rating	20 kA - 1A - 20A 50 kA - 25A - 30A
Time Constant	≤ 2ms
Material	Body: Melamine Caps: Copper Alloy
Approvals	UL 248-19 Listed (File: E339112) IEC 60269-6 (1-30 A) CSA Certified (File: 029862_0_000)
Environmental	RoHS Compliant
Country of Origin	Mexico

Part Numbering System

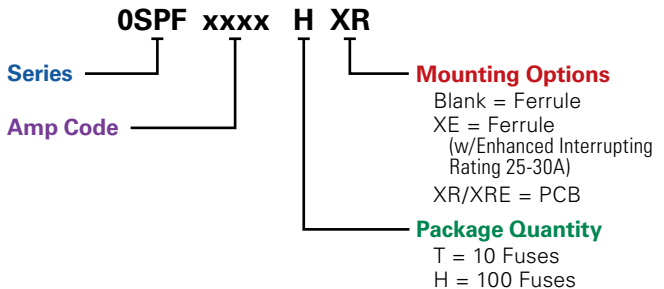

SERIES	AMP	PACKAGE QUANTITY	MOUNTING METHOD	CATALOG NUMBER	ORDERING NUMBER
SPF	2	10	FERRULE	SPF002	OSPF002.T
SPF	3.5	10	FERRULE	SPF03.5	OSPF03.5T
SPF	30	100	PCB TABS	SPF030R	OSPF030.HXR

Dimensions Inches (mm)

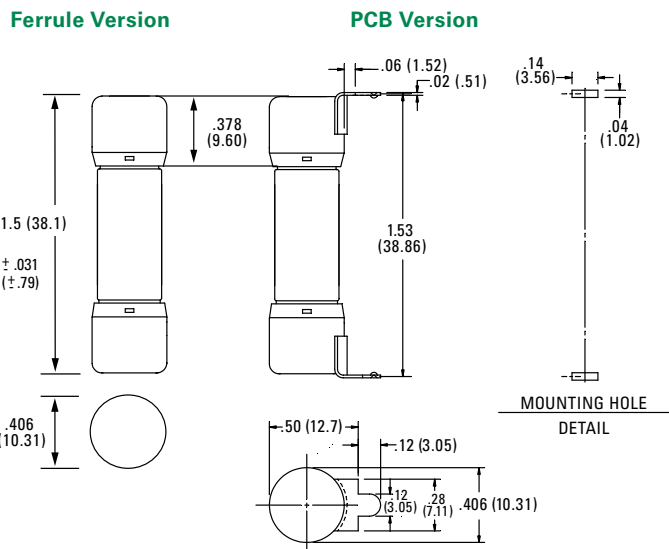

Look for this logo to indicate products that are used in solar applications. Visit our website littelfuse.com/solar for the latest updates on approvals, certifications, and new products.

SPFJ SERIES SOLAR FUSES

1000 Vdc • 70-450 A



Description

The SPFJ series is the smallest 1000 Vdc 70-450 A photovoltaic fuse available in the market. The SPFJ series is manufactured in Class J case sizes that allows for both fuse holder and busbar mounting configuration. The SPFJ meets both UL and IEC requirements.

Features/Benefits

- Meets UL and IEC photovoltaic standards
- Small footprint reduces panel size
- Flexibility of fuse holder or busbar mounting
- Higher amperage solar fuses in standard sizes
- UL Listed branch and feeder circuit rated
- Class J case sizes for the 125-450 A ratings

Applications

- Inverters
- Re-combiner boxes

Recommended Fuse Holder

LFJ1000 Solar Series

Web Resources

Download technical documents: Littelfuse.com/spfj

Specifications

Voltage Rating	1000 Vdc 600 Vac (125-450 A)
Amperage Rating	70, 80, 90, 100, 125, 160, 200, 250, 300, 350, 400, 450
Interrupting Rating	AC: 200 kAIC (125-450 A) DC: 70-200 A: 20 kAIC 250-400 A: 10 kAIC 450 A: 20 kAIC
Time Constant	≤ 1ms
Material	Body: Melamine End Bells: Copper Alloy
Approvals	UL 248-19 Listed (File: E339112) UL 248-8, Class J (125-450 A) cULus (125-450 A) IEC 60269-6 (125-450 A)
Environmental	RoHS Compliant
Country of Origin	Mexico

Part Numbering System

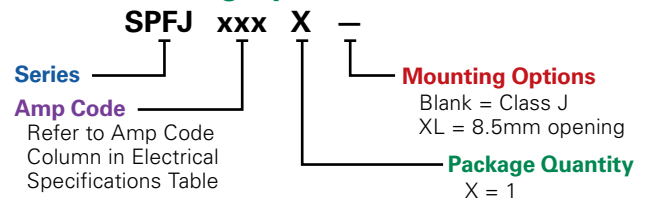

SERIES	AMP	PACKAGE QUANTITY	MOUNTING METHOD	CATALOG NUMBER	ORDERING NUMBER
SPFJ	70	1	CLASS J	SPFJ070	SPFJ070.X
SPFJ	200	1	LARGE	SPFJ200	SPFJ200.XXL

Dimensions Inches (mm)

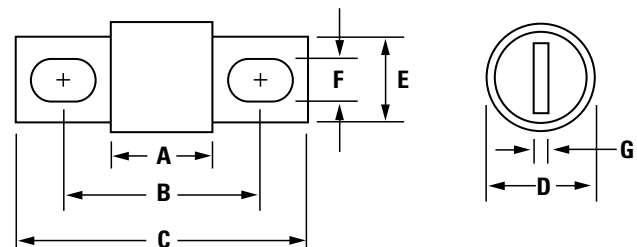

AMPERAGE	DIMENSIONS IN INCHES (MM)						
	A	B	C	D	E	F	G
70-100	3.02 (76.5)	4.38 (111.3)	5.75 (146.1)	1.5 (38.1)	1.125 (28.3)	.335 (8.5)	.189 (4.8)
125-200	3.02 (76.5)	4.38 (111.3)	5.75 (146.1)	1.5 (38.1)	1.125 (28.3)	.281 (7.1)*	.189 (4.8)
250-400	3.37 (85.7)	5.25 (133.4)	7.125 (181.0)	2.0 (50.8)	1.63 (41.3)	.406 (10.3)	.252 (6.4)
450	3.75 (95.3)	5.98 (152.0)	8.0 (203.2)	2.5 (63.5)	2.0 (50.8)	.531 (13.5)	.374 (9.5)

* SPFJ L option = 8.5 mm (UL 248-19 approval only)



Look for this logo to indicate products that are used in solar applications. Visit our website Littelfuse.com/solar for the latest updates on approvals, certifications, and new products.

FORK-LIFT STUD-MOUNTED FUSES

32/48/80 Vdc • Fast-Acting and Very Fast-Acting • 35-800 A



CNN_E, CNN & CNL Limiter Fuses

Description

CNN_E fuses are rated for applications up to 80 Vdc. As fork lift trucks voltages increase, circuit protection needs to be rated higher than the standard CNN products to handle the increased voltage. The CNN_E is considered very fast-acting for quicker reaction time.

Specifications

Voltage Ratings	CNN_E: 80 Vdc / 125 Vac CNN: 48 Vdc / 125 Vac CNL: 32 Vdc / 32 Vac
Ampere Ratings	10 – 800 A*
Max. Interrupting Rating	2,500 A
Approval	UL Recognized (File: E71611)
Environmental	RoHS Compliant, Lead (Pb) Free
Country of Origin	Mexico (CNN_E only)

*See ordering information table for available amperages by series

Ordering Information

AMPERE RATINGS CNN_E & CNN					
10 ¹	60	125	225	325	600
35	80	150	250	350	700
40	90	175	275	400	800
50	100	200	300	500	—

¹CNN Series only

AMPERE RATINGS CNL (32 Vdc)				
35	80	150	250	350
40	100	175	275	400
50	125	200	300	500
60	130	225	325	—

SERIES	TYPE	VOLT DC	AMP	CATALOG NUMBER	ORDERING NUMBER
CNN_E	VERY-FAST-ACTING	80	200	CNN200E	OCNN200E.V
CNN	VERY FAST-ACTING	48	125	CNN125	OCNN125.V
CNL	FAST-ACTING	32	50	CNL050	OCNL050.V

Recommended Fuse Holders

LFFB0003Z 123

Web Resources

littelfuse.com/ForkLift

Dimensions

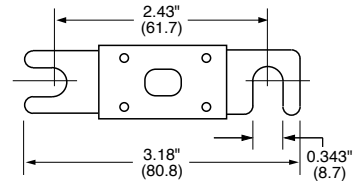

5

Special Purpose Fuses



HAZGARD™ Forklift Fuses

Description

HAZGARD fuses are designed to provide overcurrent protection for low voltage equipment used in hazardous operations. It is UL 248 recognized and has been evaluated for the use in UL 583 type EE and ES applications. Unique design does not require an additional enclosure as is needed with a standard forklift fuse, saving assembly time and costs.

Ordering Information

SERIES	AMPERAGE	CATALOG NUMBER	ORDERING NUMBER
581	200	581200	0581200.X

Applications

Lift trucks, scissor lifts, pallet movers, and other low voltage battery operated equipment used to move hazardous materials.

Features/Benefits

- Evaluated for use in UL 583 hazardous applications
- Easily upgrade Type E and ES equipment to Type EE
- Does not require an external enclosure

Specifications

Voltage Ratings	48 Vac/dc
Interrupting Rating	2,500 A
Ampere Rating	35 – 800 A
Approval	UL Recognized (File: E71611)
Torque	90 in-lb
Fuse Holder	LFFB003
Environmental	RoHS Compliant
Country of Origin	Mexico

AMPERE RATINGS			
35	100	250	500
50	125	300	750*
60	150	400	800*
90	200	425	—

*Contact factory for availability

PLUG FUSES AND BOLT-DOWN FUSES

125 Vac • 2-30 A



Edison-base plug fuses

Description

Littelfuse plug fuses provide overcurrent protection to general purpose circuits and small motor loads. Edison-base plug fuses (TOO and TLO series) feature metal threads similar to incandescent lamp bases.

Type S plug fuses (SOO and SLO series) utilize a nonmetallic threaded base and must be used with Type S adapters (SAO series).

The National Electrical Code® permits Edison base plug fuses to be used for replacement purposes only. Type S fuses and adapters prevent shunting open fuses and over-fusing.

Specifications

Voltage Rating	125 Vac
Interrupting Rating	10 kA rms symmetrical
Approvals	UL Listed 248-11

TOO fuses are dual-element time-delay Edison-base fuses designed for motor and motor branch circuit protection; also suitable for all general purpose circuits.

TOO Fuses Sample Part # 0T00020.Z

AMPERE RATINGS			
2	6 1/4	12	25
4	8	15	30
5	10	20	—

TLO fuses are medium time-delay Edison-base fuses designed for general purpose branch circuit protection.

TLO Fuses Sample Part # 0TL0020.Z

AMPERE RATINGS			
15	20	25	30

Web Resources

Fine more information: littelfuse.com/plug

32 Vac/dc • 100-300 A



MEGA® SLO-BLO® bolt-on fuse

Description

The MEGA Fuse is designed for the protection of high current applications. Designed and patented by Littelfuse, it is ideal for battery and alternator protection and other heavy gauge cable applications.

Specifications

Voltage Rating	32 Vac/dc
Interrupting Rating	2000 A @ 32 Vdc

Ordering Information

CATALOG NUMBER	ORDERING NUMBER	AMPERAGE RATING	VOLTAGE RATING	COLOR CODE
MEG100	0MEG100.X	100	32	Yellow
MEG125	0MEG125.X	125	32	Green
MEG150	0MEG150.X	150	32	Orange
MEG175	0MEG175.X	175	32	White
MEG200	0MEG200.X	200	32	Blue
MEG225	0MEG225.X	225	32	Brown
MEG250	0MEG250.X	250	32	Pink
MEG300	0MEG300.X	300	32	Grey

Recommended Fuse Holders

Part Number - 298900, see website: littelfuse.com/mega

Web Resources

Find more information: littelfuse.com/mega

LGR / LMF IN-LINE FUSES & LHR FUSE HOLDER



LGR Fuses

Fast-Acting • 300 Vac

Used as in-line protection for fluorescent fixtures, this fast-acting fuse is ideal for increasing the safety and reliability of lighting fixtures.

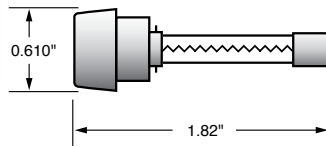

Specifications

Voltage Rating 300 Vac
Interrupting Rating 10 kA
Approvals Standard 248-14
 UL Listed (File: E10480)
 CSA Certified (File: LR29862)

Ordering Information

AMPERE RATINGS					
1/2	1 6/10	3	6	9	15
1	2	4	7	10	—
1 1/2	2 1/2	5	8	12	—

SERIES	AMPERAGE	CATALOG NUMBER	ORDERING NUMBER
LGR	5	LGR005	OLGR005.V

LMF Fuses

Time-Delay • 300 Vac

Perfect for use in lighting systems, this 300 Vac time-delay fuse is designed to handle ballast transformer in-rush currents.

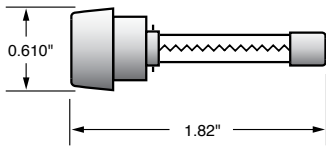

Specifications

Voltage Rating 300 Vac
Interrupting Rating 10 kA
Approvals Standard 248-14
 UL Listed (File: E10480)
 CSA Certified (File: LR29862)

Ordering Information

AMPERE RATINGS					
3/10	8/10	1 6/10	2 8/10	4	7
1/2	1	2	3	5	8
6/10	1 1/4	2 1/2	3 2/10	6 1/4	10

SERIES	AMPERAGE	CATALOG NUMBER	ORDERING NUMBER
LMF	5	LMF005	OLMF005.V

LHR Fuse Holder

Used as in-line protection for fluorescent fixtures, the Littelfuse LGR and LMF series fuses and LHR holder offer increased safety and reliability to lighting systems.

By individually fusing fixtures, electrical problems are isolated from the rest of the circuit. The added benefits of this is the ability to quickly identify the problem fixture and reduce the repair time.



Fuse holders are rated up to 10 amperes at 300 volts and are equipped with 7" 18 AWG leads. Order part number LHR000 for two leads, and part number LHR001 for one lead; with the other terminal used for insertion of 18 AWG ballast lead.

Specifications

Voltage Rating 300 Vac
Ampere Rating LHR000 10 A
 LHR001 10 A
Approvals UL Recognized
 CSA Certified (File: 73160)
Flammability Rating UL94 V-0
Example part number LHR001
Ordering number OLHR001T

Mounting Information

LHR001/LHR000 will fit keyhole punch or 0.875" knock-out hole. Anti-rotation feature is provided when used with keyhole punch.



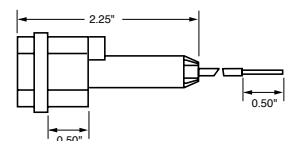
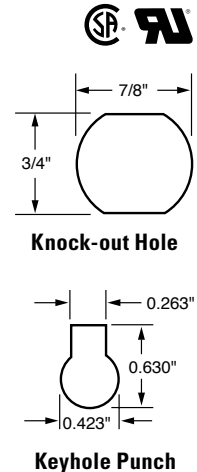

A "U-shaped" clip is available for panel mounting (packaged 10 clips per bag): Order part number LHROCA.



LFCL • CABLE LIMITERS

250/600 VAC



TYPE	TERMINATION	VOLTAGE RATING	COPPER CABLE SIZE	ORDERING NUMBER
1	 CABLE TO CABLE	600 VAC	4 AWG	LFCL0004ZC1
		600 VAC	3 AWG	LFCL0003ZC1
		600 VAC	2 AWG	LFCL0002ZC1
		600 VAC	1 AWG	LFCL0001ZC1
		600 VAC	1/0 AWG	LFCL01/0ZC1
		600 VAC	2/0 AWG	LFCL02/0ZC1
		600 VAC	3/0 AWG	LFCL03/0ZC1
		600 VAC	4/0 AWG	LFCL04/0ZC1
		600 VAC	250 kcmil	LFCL0250ZC1
		600 VAC	350 kcmil	LFCL0350ZC1
		600 VAC	500 kcmil	LFCL0500ZC1
		600 VAC	600 kcmil	LFCL0600ZC1
3	 CABLE TO OFFSET BUS	600 VAC	12 AWG	LFCL0012ZC3
		600 VAC	10 AWG	LFCL0010ZC3
		600 VAC	6 AWG	LFCL0006ZC3
		600 VAC	4 AWG	LFCL0004ZC3
		600 VAC	2 AWG	LFCL0002ZC3
		600 VAC	1 AWG	LFCL0001ZC3
		600 VAC	1/0 AWG	LFCL01/0ZC3
		600 VAC	2/0 AWG	LFCL02/0ZC3
		600 VAC	3/0 AWG	LFCL03/0ZC3
		600 VAC	4/0 AWG	LFCL04/0ZC3
		600 VAC	250 kcmil	LFCL0250ZC3
		600 VAC	350 kcmil	LFCL0350ZC3
5	 STRAIGHT BUS TO OFFSET BUS	250 VAC	2/0 & 3/0 AWG	LFCL-UHA*
		250 VAC	3/0 AWG	LFCL-UHJ-M*
		250 VAC	350 kcmil	LFCL-UHJ-T*
		250 VAC	600 kcmil	LFCL-UHJ-W*
		600 VAC	4/0 AWG	LFCL04/0ZC5*
		600 VAC	250 kcmil	LFCL0250ZC5*
		600 VAC	350 kcmil	LFCL0350ZC5*
		600 VAC	500 kcmil	LFCL0500ZC5*
6	 MOLE TO CABLE	600 VAC	4/0 AWG	LFCL04/0ZC6
		600 VAC	250 kcmil	LFCL0250ZC6
		600 VAC	500 kcmil	LFCL0500ZC6
		600 VAC	500 kcmil	LFCL0500ZC6

*Suitable for use with aluminum cables / conductors. For sizing contact Tech-Line at 800-TEC-FUSE.

Description

Cable limiters are fusible devices that provide very fast short-circuit protection, primarily to faulted cables, but also to other conductors such as busway. Cable limiters do not have an ampere rating, and cannot be used to provide overload protection. They are instead selected by cable size; for example, a 500 kcmil cable requires a 500 kcmil cable limiter. Their main use is to isolate faulted cables in circuits containing three or more parallel conductors per phase. They may be installed on the line side of the main service to provide short-circuit protection to the service conductors. This is especially important when service conductors are tapped from large low voltage networks or from large low impedance transformers.

Cable limiters have terminals which permit them to be installed in a variety of equipment. The most common configuration is the offset blade on one end and the crimp terminal on the other end. This permits the limiter to replace a cable terminal (lug).

Applications

- Service Entrance Conductors
- Between Transformer or network bus and bus-way terminal boxes as secondary ties.
- Feeders with three or more conductors per phase to share heavier load in large commercial and industrial installations
- Multiple Single conductor services, tapped from single (utility) transformer in multi-family residential and small commercial installations.

Features

- Current-limiting characteristics provide protection to conductor insulation and reduce damage when faults occur.
- Properly applied cable limiters may permit the use of equipment with reduced withstand ratings
- Wide variety of terminations and cable ratings permit use in almost every situation.

Specifications

Voltage Ratings	250 VAC, 600 VAC
Interrupting Rating	100 kA (250 VAC), 200 kA (600 VAC)
Cable Size Range	12 AWG – 1000Kcmil Copper
Approvals	Contact Tech-Line at 800-TEC-FUSE
Recommended Installation Tool	Make: Thomas & Betts Crimp Tool: TBM14_, TBM15_

Web Resources

For additional information, see website:
littelfuse.com/lc

CYLINDRICAL FUSES

500 Volts • 0.5-100 A



Description

Littelfuse fast acting (gL-gG) fuses are used for the protection of cables against short-circuits. Time-lag (aM) fuses are used for protection of motors.

Specifications

Standards

10x38 mm: IEC 60269
14x51 mm / 22x58mm: IEC 269-2-1

Ordering Information

BASE PART NUMBER	SIZE (mm)	CURRENT RANGE	VOLTAGE (AC)	INTERRUPTING RATING
CY10X38	10 x 38	0.5-16 A	500 V	120 kA
		20-25 A (aM)	400 V	120 kA
		20-25 A (gL-gG)	500 V	120 kA
		32 A	400 V	120 kA
CY14X51	14 x 51	2-25 A	690 V	80 kA
		32-40 A	500 V	120 kA
		50 A	400 V	120 kA
CY22X58	22 x 58	16-63 A	690 V	80 kA
		80-100 A	500 V	120 kA

AMPERAGE	gL-gG ORDERING NUMBERS			aM ORDERING NUMBERS		
	10 X 38	14 X 51	22 X 58	10 X 38	14 X 51	22 X 58
0.5	CY10X38G05	—	—	CY10X38M05	—	—
1	CY10X38G1	—	—	CY10X38M1	—	—
2	CY10X38G2	CY14X51G2	—	CY10X38M2	CY14X51M2	—
4	CY10X38G4	CY14X51G4	—	CY10X38M4	CY14X51M4	—
6	CY10X38G6	CY14X51G6	—	CY10X38M6	CY14X51M6	—
8	CY10X38G8	CY14X51G8	—	CY10X38M8	CY14X51M8	—
10	CY10X38G10	CY14X51G10	—	CY10X38M10	CY14X51M10	—
12	CY10X38G12	CY14X51G12	—	CY10X38M12	CY14X51M12	—
16	CY10X38G16	CY14X51G16	CY22X58G16	CY10X38M16	CY14X51M16	CY22X58M16
20	CY10X38G20	CY14X51G20	CY22X58G20	CY10X38M20	CY14X51M20	CY22X58M20
25	CY10X38G25	CY14X51G25	CY22X58G25	CY10X38M25	CY14X51M25	CY22X58M25
32	CY10X38G32	CY14X51G32	CY22X58G32	CY10X38M32	CY14X51M32	CY22X58M32
40	—	CY14X51G40	CY22X58G40	—	CY14X51M40	CY22X58M40
50	—	CY14X51G50	CY22X58G50	—	CY14X51M50	CY22X58M50
63	—	—	CY22X58G63	—	—	CY22X58M63
80	—	—	CY22X58G80	—	—	CY22X58M80
100	—	—	CY22X58G100	—	—	CY22X58M100

Dimensions

FUSE SIZE	DIMENSIONS mm	
	A	B
10 X 38	10	38
14 X 51	14	51
22 X 58	22	58

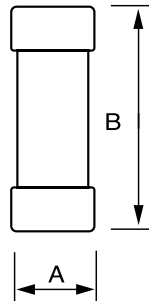

Fuse Holders

AMP RATING	POLES	SIZE	CATALOG / ORDERING #	TERMINAL TYPE	DIN RAIL MOUNT
32 A	1	10 X 38	LFPSM0001Z	Pressure Plate	•
32 A	2	10 X 38	LFPSM0002Z	Pressure Plate	•
32 A	3	10 X 38	LFPSM0003Z	Pressure Plate	•
32 A	4	10 X 38	LFPSM0004Z	Pressure Plate	•
32 A	1	10 X 38	LFPSM0001ZXID*	Pressure Plate	•
32 A	2	10 X 38	LFPSM0002ZXID*	Pressure Plate	•
32 A	3	10 X 38	LFPSM0003ZXID*	Pressure Plate	•
32 A	4	10 X 38	LFPSM0004ZXID*	Pressure Plate	•
50 A	1	14 X 51	CYH14511	Pressure Plate	•
50 A	2	14 X 51	CYH14512	Pressure Plate	•
50 A	3	14 X 51	CYH14513	Pressure Plate	•
100 A	1	22 X 58	CYH22581	Pressure Plate	•
100 A	2	22 X 58	CYH22582	Pressure Plate	•
100 A	3	22 X 58	CYH22583	Pressure Plate	•

* Indicating

Web Resources

For additional product information

Fuses: littelfuse.com/cy

Fuse Holders: littelfuse.com/lfpsm
littelfuse.com/cyh

OEM CUSTOM PRODUCTS

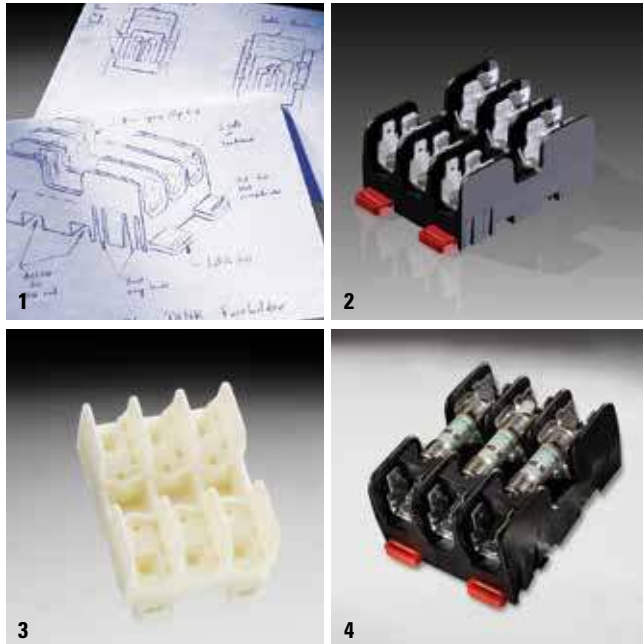

To speak with a sales associate regarding your application needs, call 800-TEC-FUSE (800-382-3873) or email techline@littelfuse.com.

Examples



Two-Pole Combination Block

Save space and money by combining multiple components in one unit. Littelfuse collaborated with the customer to develop a cost effective UL listed component that combined a 600 Volt 100A two-pole Class T fuse block with a two-openings-per-pole splicer block.

Description

We understand that existing solutions don't always solve your current problems. Building on 90 years of circuit protection experience, the Littelfuse engineering team collaborates with customers to develop customized solutions for applications such as solar panels, HVAC systems, lift trucks, lighting fixtures, industrial restaurant equipment and power converters.

Process

The custom product design process begins with a situation analysis from our experienced engineers followed by our 4-step collaborative product development process.

1. Initial concept sketch created
2. CAD drawings to formalize the product description
3. 3D solid prototype to verify design
4. Final production parts that meet your design needs and specifications

Additional Customized Products

HAZGARD Fork Lift Fuse64

Web Resources

To learn more and contact our OEM team, visit: littelfuse.com/industrialoem



Custom-Leaded Fuse

Save space and reduce cost by eliminating the fuse block component. Littelfuse designed a series of custom through-hole PC-board mountable KLKD Midget fuses for a consumer application where reduced cost was more important than replaceability.

Section Overview

Littelfuse high-speed fuses protect critical power semiconductors against short circuits in applications including inverters, variable-speed drives, UPS and DC drive systems.

For the complete portfolio of high-speed products visit:
littelfuse.com/High-Speed



HIGH-SPEED FUSES

Table of Contents

High-Speed Square Body Fuses	71
High-Speed Round-Body Fuses	76
Traditional High-Speed Fuses	86



POWR-GARD® High-Speed Circuit Protection

Littelfuse engineering is constantly developing new products to meet the needs of the industry. For the latest information on the growing POWR-GARD Product portfolio, visit:

littelfuse.com/High-Speed

PSR SERIES HIGH-SPEED SQUARE BODY FUSES

Semiconductor Fuses • Flush End • 40 A - 2000 A



Description

Littelfuse PSR Series High-Speed Square Body Fuses are specially designed for protection of power semiconductor devices such as diodes, triacs, IGBTs, SCRs, MOSFETs and other solid state devices that are typically designed into power conversion and power conditioning equipment. Variable frequency drives, inverters, UPS, rectifiers and soft-starters are examples of typical equipment designed with sensitive power semiconductor devices that cannot withstand any line surge or overcurrent conditions and require high-speed protection.

Littelfuse POWR-SPEED® PSR Series products offer optimized circuit protection at the extremely fast speed required to protect modern day power conversion devices. Such products are commonly found in numerous applications including pulp and paper industries, cranes and heavy-lifting equipment, processing industries, wastewater treatment plants and various large factories and MRO facilities.

Features/Benefits

- Best in Class DC performance
- Extremely current limiting
- Superior cycling capability
- Global certification cURus, CCC, IEC
- Direct bus-bar mount design
- Visual and optional microswitch fuse blown indication
- Low watt-loss design
- Compliance with US and Canadian requirements
- Class aR performance according to IEC60269-4

Applications

- Power Conversion Devices (UPS, Inverter, Rectifiers, Drives)
- DC Systems (DC Common Bus, DC Injection Braking)
- Battery Protection Application (Energy Storage Systems)
- Electric Vehicle Charging Stations
- Heaters and Power Supplies

Specifications

Voltage Range	AC: 550 V - 1300 V DC: 500 V - 1000 V
Amperage Range	40 A - 2000 A
Interrupting Range	AC: 100 kA - 200 kA DC: 150 kA
Time Constant	10ms
Microswitch	Yes
Mounting	Flush-End Style
Material	Body: Ceramic Contacts: Plated Brass
Approvals	UL 248-13 Recognized (File: E71611) cURus (File: E71611) IEC 60269-4 (Class aR) CCC
Environmental	RoHS Compliant, REACH
Operating Temperature	-55 C° to +125 C°
Storage Temperature	Up-to +35 C° with Relative Humidity <65%
Country of Origin	Mexico

Ordering Part Number

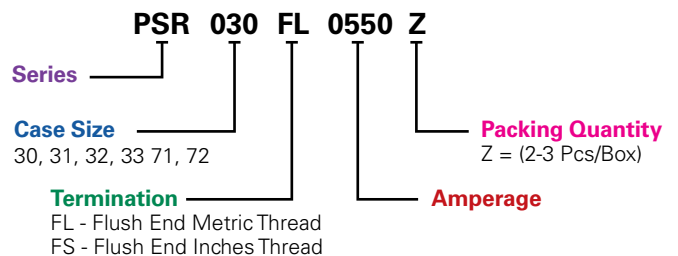

Catalog Number

SERIES	CASE SIZE	TERMINATION	AMPERAGE	CATALOG NUMBER	ORDERING PART NUMBER
PSR	030	FL	0550	PSR030FL0550	PSR030FL0550Z

Recommended Accessories

Microswitch: MS3H1000C (Case Size 30 to 33)
MS7H1500C (Case Size 70 to 73)

Web Resources

Download technical documents: littelfuse.com/psr

PSR SERIES HIGH-SPEED SQUARE BODY FUSES

Electrical Characteristics

CASE SIZE*	CATALOG NUMBER		AMPERAGE RATING (A)	VOLTAGE RATING (V)			INTERRUPTING RATING		MELTING (PRE-ARC) I ² T (A ² s)	TOTAL CLEARING I ² T (A ² s) AT RATED VOLTAGE		WATT LOSS AT 100% RATED CURRENT (W)	AGENCY CERTIFICATION	
	FLUSH END METRIC THREAD	FLUSH END INCHES THREAD		AC		DC	AC	DC		AC	DC		cURus	CCC
				IEC	UL									
30	PSR030FL0040	PSR030FS0040	40	690	700	600	200kA	150kA	76	280	260	12	•	•
	PSR030FL0050	PSR030FS0050	50	690	700	600	200kA	150kA	110	598	384	15	•	•
	PSR030FL0063	PSR030FS0063	63	690	700	600	200kA	150kA	176	1023	640	20	•	•
	PSR030FL0080	PSR030FS0080	80	690	700	600	200kA	150kA	304	1728	1252	24	•	•
	PSR030FL0100	PSR030FS0100	100	690	700	600	200kA	150kA	437	2835	1575	27	•	•
	PSR030FL0125	PSR030FS0125	125	690	700	600	200kA	150kA	707	4684	2783	36	•	•
	PSR030FL0160	PSR030FS0160	160	690	700	600	200kA	150kA	1359	9114	5507	39	•	•
	PSR030FL0200	PSR030FS0200	200	690	700	600	200kA	150kA	3012	15169	14700	39	•	•
	PSR030FL0250	PSR030FS0250	250	690	700	600	200kA	150kA	4668	29952	20833	50	•	•
	PSR030FL0315	PSR030FS0315	315	690	700	600	200kA	150kA	7131	61830	31600	61	•	•
	PSR030FL0350	PSR030FS0350	350	690	700	600	200kA	150kA	12007	85320	49273	62	•	•
	PSR030FL0400	PSR030FS0400	400	690	700	600	200kA	150kA	16209	114750	63367	75	•	•
	PSR030FL0450	PSR030FS0450	450	690	700	600	200kA	150kA	23133	160110	93533	75	•	•
PSR030FL0500	PSR030FS0500	500	690	700	600	200kA	150kA	31429	225180	137333	80	•	•	
PSR030FL0550	PSR030FS0550	550	690	700	600	200kA	150kA	44323	268920	145400	78	•	•	
31	PSR031FL0200	PSR031FS0200	200	690	700	600	200kA	150kA	1965	17334	16188	49	•	•
	PSR031FL0250	PSR031FS0250	250	690	700	600	200kA	150kA	3789	35343	21080	52	•	•
	PSR031FL0315	PSR031FS0315	315	690	700	600	200kA	150kA	6862	59130	30694	61	•	•
	PSR031FL0350	PSR031FS0350	350	690	700	600	200kA	150kA	9523	76140	40996	63	•	•
	PSR031FL0400	PSR031FS0400	400	690	700	600	200kA	150kA	14770	124335	64359	63	•	•
	PSR031FL0450	PSR031FS0450	450	690	700	600	200kA	150kA	22457	178200	97444	68	•	•
	PSR031FL0500	PSR031FS0500	500	690	700	600	200kA	150kA	29751	251505	125935	74	•	•
	PSR031FL0550	PSR031FS0550	550	690	700	600	200kA	150kA	42056	289170	171845	79	•	•
	PSR031FL0630	PSR031FS0630	630	690	700	600	200kA	150kA	73513	507465	276315	86	•	•
	PSR031FL0700	PSR031FS0700	700	690	700	600	200kA	150kA	98187	601425	337260	89	•	•
PSR031FL0800	PSR031FS0800	800	690	700	600	200kA	150kA	137208	848880	502800	107	•	•	
32	PSR032FL0400	PSR032FS0400	400	690	700	600	200kA	150kA	11104	79650	44533	82	•	•
	PSR032FL0450	PSR032FS0450	450	690	700	600	200kA	150kA	15535	116100	65463	88	•	•
	PSR032FL0500	PSR032FS0500	500	690	700	600	200kA	150kA	21573	161460	88277	94	•	•
	PSR032FL0550	PSR032FS0550	550	690	700	600	200kA	150kA	26327	177660	107960	104	•	•
	PSR032FL0630	PSR032FS0630	630	690	700	600	200kA	150kA	34790	234900	156963	110	•	•
	PSR032FL0700	PSR032FS0700	700	690	700	600	200kA	150kA	51191	291870	209287	117	•	•
	PSR032FL0800	PSR032FS0800	800	690	700	600	200kA	150kA	60125	472770	249000	145	•	•
	PSR032FL0900	PSR032FS0900	900	690	700	600	200kA	150kA	107785	764100	404000	145	•	•
	PSR032FL1000	PSR032FS1000	1000	690	700	600	200kA	150kA	190102	933120	672333	146	•	•
PSR032FL1100	PSR032FS1100	1100	690	700	600	200kA	150kA	225379	1247400	744000	149	•	•	

PSR SERIES HIGH-SPEED SQUARE BODY FUSES

Electrical Characteristics (cont.)

CASE SIZE*	CATALOG NUMBER		AMPERAGE RATING (A)	VOLTAGE RATING (V)		INTERRUPTING RATING		MELTING (PRE-ARC) I ² T (A ² s)	TOTAL CLEARING I ² T (A ² s) AT RATED VOLTAGE		WATT LOSS AT 100% RATED CURRENT (W)	AGENCY CERTIFICATION		
	FLUSH END METRIC THREAD	FLUSH END INCHES THREAD		AC		DC	AC		DC	AC		DC	cURus	CCC
				IEC	UL									
33	PSR033FL0450	PSR033FS0450	450	690	700	600	200kA	150kA	13600	106380	58947	99	•	•
	PSR033FL0500	PSR033FS0500	500	690	700	600	200kA	150kA	16434	140400	77846	107	•	•
	PSR033FL0550	PSR033FS0550	550	690	700	600	200kA	150kA	23314	187650	100461	108	•	•
	PSR033FL0630	PSR033FS0630	630	690	700	600	200kA	150kA	38727	285930	142437	113	•	•
	PSR033FL0700	PSR033FS0700	700	690	700	600	200kA	150kA	56763	392580	209863	113	•	•
	PSR033FL0800	PSR033FS0800	800	690	700	600	200kA	150kA	84691	575505	348500	120	•	•
	PSR033FL0900	PSR033FS0900	900	690	700	600	200kA	150kA	122619	740340	451177	122	•	•
	PSR033FL1000	PSR033FS1000	1000	690	700	600	200kA	150kA	222350	1170450	787750	124	•	•
	PSR033FL1100	PSR033FS1100	1100	690	700	600	200kA	150kA	310824	1568700	821400	127	•	•
	PSR033FL1250	PSR033FS1250	1250	690	700	600	200kA	150kA	476902	2403000	1674333	131	•	•
	PSR033FL1400	PSR033FS1400	1400	690	700	500	200kA	150kA	583552	2920050	1979750	144	•	•
	PSR033FL1500	PSR033FS1500	1500	600	650	500	200kA	150kA	674538	2433200	1996733	163	•	•
	PSR033FL1600	PSR033FS1600	1600	600	650	500	200kA	150kA	779948	2942800	2301633	182	•	•
PSR033FL1800	PSR033FS1800	1800	600	650	500	200kA	150kA	952196	3785040	2724180	224	•	•	
PSR033FL2000	PSR033FS2000	2000	550	600	500	200kA	150kA	1234315	4131600	3755180	222	•	•	
71	PSR071FL0160	PSR071FS0160	160	1250	1300	1000	100kA	150kA	2601	22550	9767	45	•	•
	PSR071FL0200	PSR071FS0200	200	1250	1300	1000	100kA	150kA	5188	41738	20333	53	•	•
	PSR071FL0250	PSR071FS0250	250	1250	1300	1000	100kA	150kA	10215	82000	41000	55	•	•
	PSR071FL0280	PSR071FS0280	280	1250	1300	1000	100kA	150kA	10215	82000	41000	55	•	•
	PSR071FL0315	PSR071FS0315	315	1250	1300	1000	100kA	150kA	21859	156347	75500	55	•	•
	PSR071FL0350	PSR071FS0350	350	1250	1300	1000	100kA	150kA	25199	180400	89333	65	•	•
	PSR071FL0400	PSR071FS0400	400	1250	1300	1000	100kA	150kA	40153	256933	143333	69	•	•
PSR071FL0450	PSR071FS0450	450	1250	1300	1000	100kA	150kA	55163	340822	191600	75	•	•	
72	PSR072FL0500	PSR072FS0500	500	1250	1300	1000	100kA	150kA	55452	340300	196667	107	•	•
	PSR072FL0550	PSR072FS0550	550	1250	1300	1000	100kA	150kA	65119	431867	246667	114	•	•
	PSR072FL0630	PSR072FS0630	630	1250	1300	1000	100kA	150kA	114904	663790	404000	107	•	•

* Case Size 70 and 73 – Coming Soon

PSR SERIES HIGH-SPEED SQUARE BODY FUSES

Dimensions Millimeters [inches]

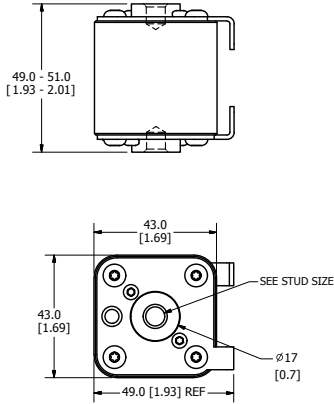

30 Case Size

Document Number: OL-PSR030FL0000 Rev. B and
OL-PSR030FS0000 Rev. B

FL Stud Size: M8 x 1.25 - 6H ∇ 6.0 [0.24]

FS Stud Size: 5/16-18UNC -2B ∇ 6.0 [0.24]

Recommended Torque: 13.5 Nm

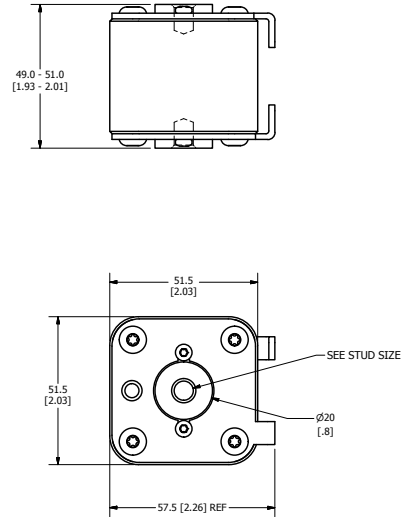

31 Case Size

Document Number: OL-PSR030FL0000 Rev. B and
OL-PSR031FL0000 Rev. B

FL Stud Size: M8x1.25 - 6H ∇ 8.0 [0.31]

FS Stud Size: 5/16-18 UNC -2B ∇ 8.0 [0.31]

Recommended Torque: 13.5 Nm

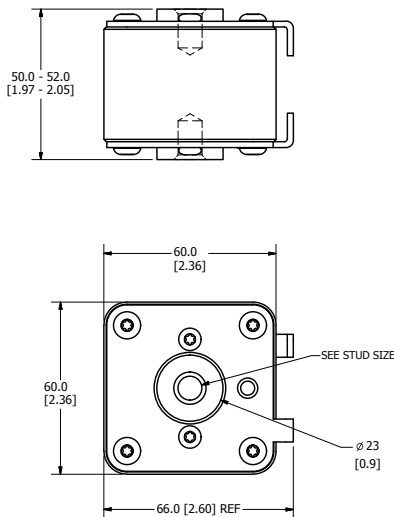

32 Case Size

Document Number: OL-PSR032FL0000 Rev. B and
OL-PSR032FS0000 Rev. B

FL Stud Size: M10x1.5 - 6H ∇ 11.5 [0.45]

FS Stud Size: 3/8-16UNC -2B ∇ 11.5 [0.45]

Recommended Torque: 26 Nm

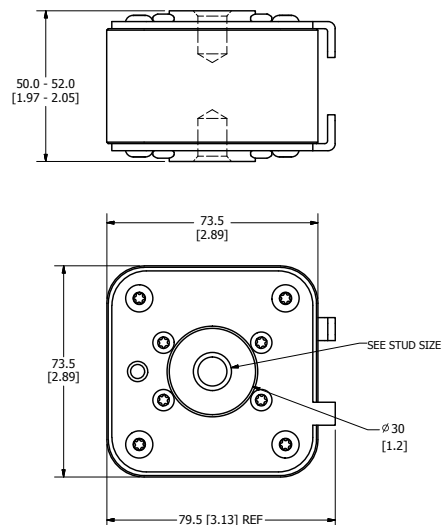

33 Case Size

Document Number: OL-PSR033FL0000 Rev. B and
OL-PSR033FS0000 Rev. B

FL Stud Size: M12x1.75 - 6H ∇ 13.0 [0.51]

FS Stud Size: 1/2-13UNC -2B ∇ 13.0 [0.51]

Recommended Torque: 45 Nm

PSR SERIES HIGH-SPEED SQUARE BODY FUSES

Dimensions Millimeters [inches]

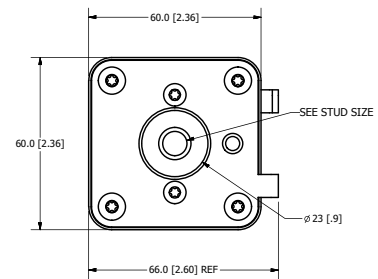
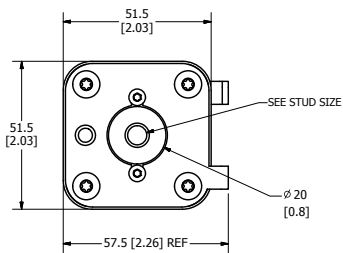
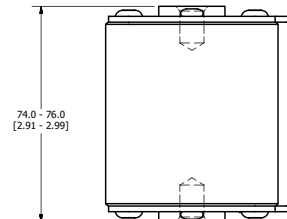
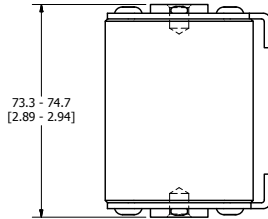

71 Case Size

Document Number: OL-PSR071FL0000 Rev. B and
OL-PSR071FS0000 Rev. B

FL Stud Size: M8x1.25 - 6H ∇ 8.0 [0.31]

FS Stud Size: 5/16-18UNC -2B ∇ 8.0 [0.31]

Recommended Torque: 13.5 Nm

72 Case Size

Document Number: OL-PSR072FL0000 Rev. B and
OL-PSR072FS0000 Rev. B

FL Stud Size: M10x1.5 - 6H ∇ 11.5 [0.45]

FS Stud Size: 3/8-16UNC -2B ∇ 11.5 [0.45]

Recommended Torque: 26 Nm

L50QS SERIES HIGH-SPEED ROUND-BODY FUSES

500 Vac/dc • 35-800 A • Traditional Round-Body Bolted Style



Specifications

Voltage Rating	AC: 500V DC: 500V
Amperage Rating	35 - 800
Interrupting Rating	AC: 200 kA DC: 50 kA
Material	Body: Melamine Caps: Copper Alloy (Silver Plated)
Approvals	UL Recognized (E71611) c-UR-us (E71611)
Environmental	RoHS Compliant, REACH
Country of Origin	Mexico
Operating Temperature	-55C to +125C
Storage Temperature	Up to 35C with Relative Humidity <65%

Description

The L50QS Series is a next generation High-Speed Fuse for the protection of power semiconductor devices and is designed in the Traditional North American Bolted Style package.

L50QS Series High-Speed Fuses are extremely current limiting and are used to protect power converters, drives and control circuit applications. Designed with lower I²t performance characteristics, these fuses provide balanced performance to extend longevity while lowering potentially damaging heat energy to the devices being protected.

In addition L50QS Series fuses have been designed with a universal mounting option to meet customer requirements for installation into a variety of application configurations

Littelfuse POWR-SPEED™ products offer optimized circuit protection at the extremely fast speed required to protect modern day, sensitive, high-power semiconductor devices. Such products are commonly found in various industries including pulp and paper industries, cranes and heavy-lifting equipment, processing industries, wastewater treatment plants and large factories and MRO facilities.

Features/Benefits

- Compliance with US and Canadian Requirements
- Traditional North American Bolted Style dimensions
- Class aR performance
- Direct bus-bar mount or stud mount design
- RoHS and REACH Compliant

Applications

- Power Converters (Inverters, Rectifiers)
- Power Supplies
- UPS
- Variable Speed Drives
- Control Circuits
- Soft Starters

Part Numbering System

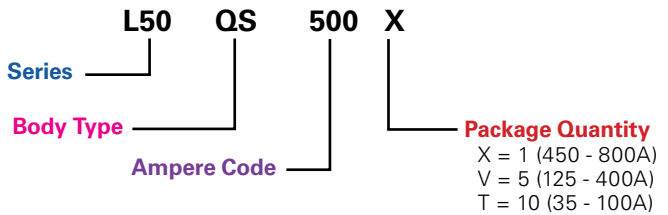

SERIES	BODY TYPE	AMPERE CODE	PACKAGE QUANTITY	CATALOG NUMBER	ORDERING NUMBER
L50	QS	500	1	L50QS500	L50QS500.X

Recommended Fuse Blocks

LSCR001 (35-200 A)	127
LSCR002 (225-800 A)	127



Web Resources

Download technical documents: littelfuse.com/L50QS

L50QS SERIES HIGH-SPEED ROUND-BODY FUSES

Electrical Specifications

CATALOG NUMBER	AMPERAGE RATING	VOLTAGE RATING		INTERRUPT RATING		MELTING (PRE-ARC) I ² T (A ² s)	TOTAL CLEARING I ² T (A ² s)	TOTAL CLEARING I ² T (A ² s)	WATTS LOSS AT 80% RATED CURRENT	WATTS LOSS AT 100% RATED CURRENT
		AC	DC	AC	DC		200 kA @ 500 Vac	50 kA @ 500 Vdc	(W)	(W)
L50QS035	35	500	500	200kA	50kA	111	430	290	3	5
L50QS040	40	500	500	200kA	50kA	137	530	363	3	9
L50QS050	50	500	500	200kA	50kA	211	770	516	5	8
L50QS060	60	500	500	200kA	50kA	269	1,500	881	5	9
L50QS070	70	500	500	200kA	50kA	393	1,775	1,185	6	11
L50QS080	80	500	500	200kA	50kA	616	3,550	1,720	6	11
L50QS090	90	500	500	200kA	50kA	720	4,075	1,990	8	14
L50QS100	100	500	500	200kA	50kA	905	4,577	2,313	9	17
L50QS125	125	500	500	200kA	50kA	1,503	7,655	4,815	10	17
L50QS150	150	500	500	200kA	50kA	2,382	11,100	7,190	12	21
L50QS175	175	500	500	200kA	50kA	3,148	16,500	9,900	14	25
L50QS200	200	500	500	200kA	50kA	4,102	18,233	11,567	17	32
L50QS225	225	500	500	200kA	50kA	5,379	25,300	16,700	19	35
L50QS250	250	500	500	200kA	50kA	7,094	31,350	22,500	20	37
L50QS300	300	500	500	200kA	50kA	11,240	53,800	36,150	25	46
L50QS350	350	500	500	200kA	50kA	14,246	68,850	44,800	30	61
L50QS400	400	500	500	200kA	50kA	21,155	100,300	67,300	33	65
L50QS450	450	500	500	200kA	50kA	26,425	121,000	84,650	35	63
L50QS500	500	500	500	200kA	50kA	31,747	141,000	103,500	39	72
L50QS600	600	500	500	200kA	50kA	43,922	193,500	128,000	49	92
L50QS700	700	500	500	200kA	50kA	75,597	314,000	230,000	51	92
L50QS800	800	500	500	200kA	50kA	92,717	393,500	280,000	63	117

5

High-Speed Fuses

L50QS SERIES HIGH-SPEED ROUND-BODY FUSES

Dimensions Millimeters [inches]

Document Number: OL-L50QS000

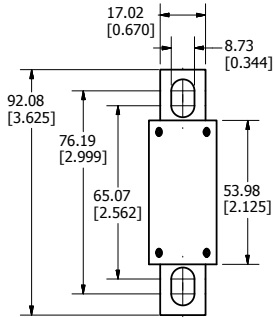

35-100A

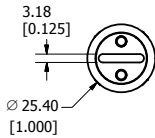

Stud Size: M8 (⁵/₁₆"")
Recommended Torque: 15 Nm (132.76 in-lb)

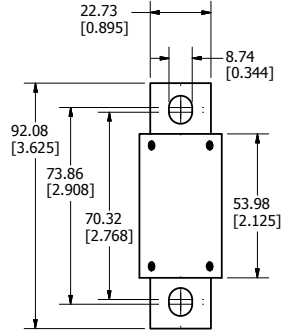

125-200A

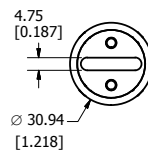

Stud Size: M8 (⁵/₁₆"")
Recommended Torque: 15 Nm (132.76 in-lb)

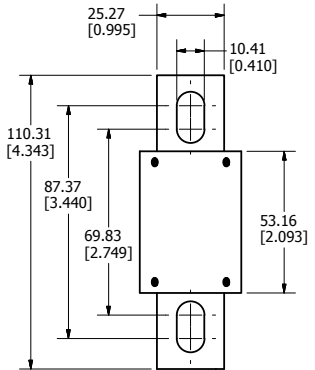

225-400A

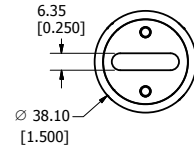

Stud Size: M8 (⁵/₁₆"")
Recommended Torque: 15 Nm (132.76 in-lb)

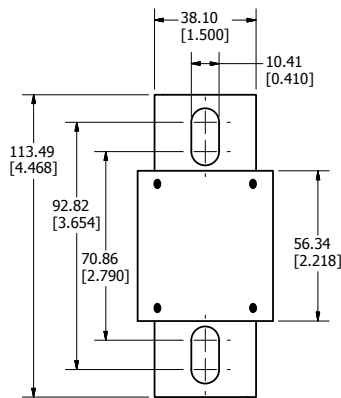

450-600A

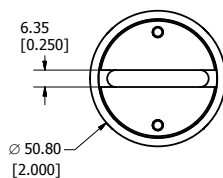

Stud Size: M8 (⁵/₁₆"")
Recommended Torque: 15 Nm (132.76 in-lb)

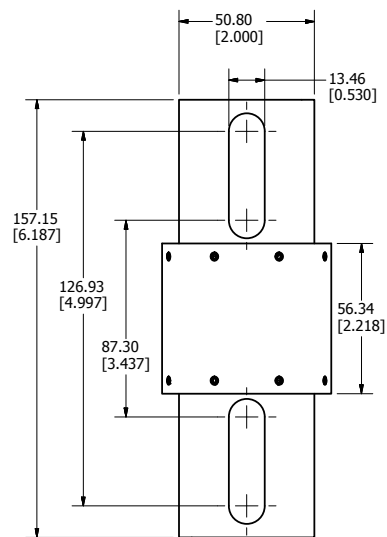

700-800A

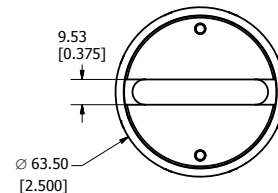

Stud Size: M12 (¹/₂"")
Recommended Torque: 54 Nm (477.94 in-lb)

L70QS SERIES HIGH-SPEED ROUND-BODY FUSES

700 Vac/dc • 35-800 A • Traditional Round-Body Bolted Style



Description

The L70QS Series is a next generation High-Speed Fuse for the protection of power semiconductor devices and is designed in the Traditional North American Bolted Style package.

L70QS Series High-Speed Fuses are extremely current limiting and are used to protect power converters, drives and control circuit applications. Designed with lower I²t performance characteristics, these fuses provide balanced performance to extend longevity while lowering potentially damaging heat energy to the devices being protected.

In addition L70QS Series fuses have been designed with a universal mounting option to meet customer requirements for installation into a variety of application configurations

Littelfuse POWR-SPEED™ products offer optimized circuit protection at the extremely fast speed required to protect modern day, sensitive, high-power semiconductor devices. Such products are commonly found in various industries including pulp and paper industries, cranes and heavy-lifting equipment, processing industries, wastewater treatment plants and large factories and MRO facilities.

Features/Benefits

- Compliance with US and Canadian Requirements
- Traditional North American Bolted Style dimensions
- Class aR performance
- Direct bus-bar mount or stud mount design
- RoHS and REACH Compliant

Applications

- Power Converters (Inverters, Rectifiers)
- Power Supplies
- UPS
- Variable Speed Drives
- Control Circuits
- Soft Starters

Specifications

Voltage Rating	AC: 700V DC: 700V
Amperage Rating	35 - 800
Interrupting Rating	AC: 200 kA DC: 50 kA
Material	Body: Melamine Caps: Copper Alloy (Silver Plated)
Approvals	UL Recognized (E71611) c-UR-us (E71611)
Environmental	RoHS Compliant, REACH
Country of Origin	Mexico
Operating Temperature	-55C to +125C
Storage Temperature	Up to 35C with Relative Humidity <65%

Part Numbering System

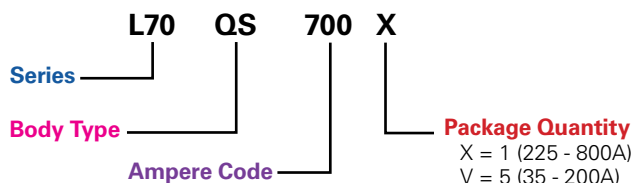

SERIES	BODY TYPE	AMPERE CODE	PACKAGE QUANTITY	CATALOG NUMBER	ORDERING NUMBER
L70	QS	700	1	L70QS700	L70QS700.X

Recommended Fuse Blocks

LSCR001 (35-200 A).....	127
LSCR002 (225-800 A).....	127



Web Resources

Download technical documents: littelfuse.com/L70QS

L70QS SERIES HIGH-SPEED ROUND-BODY FUSES

Electrical Specifications

CATALOG NUMBER	AMPERAGE RATING	VOLTAGE RATING		INTERRUPT RATING		MELTING (PRE-ARC) I ² T (A ² s)	TOTAL CLEARING I ² T (A ² s)	TOTAL CLEARING I ² T (A ² s)	WATTS LOSS AT 80% RATED CURRENT	WATTS LOSS AT 100% RATED CURRENT
		AC	DC	AC	DC		200 kA @ 700 Vac	50 kA @ 700 Vdc	(W)	(W)
L70QS035	35	700	700	200kA	50kA	129	332	308	5	8
L70QS040	40	700	700	200kA	50kA	153	599	416	6	9
L70QS050	50	700	700	200kA	50kA	196	711	588	6	12
L70QS060	60	700	700	200kA	50kA	269	1,233	678	9	15
L70QS070	70	700	700	200kA	50kA	359	1,575	1,075	10	20
L70QS080	80	700	700	200kA	50kA	452	2,755	1,415	12	22
L70QS090	90	700	700	200kA	50kA	625	3,365	1,920	13	25
L70QS100	100	700	700	200kA	50kA	966	3,747	2,347	15	30
L70QS125	125	700	700	200kA	50kA	2,208	8,795	5,570	13	24
L70QS150	150	700	700	200kA	50kA	3,026	13,650	8,195	17	32
L70QS175	175	700	700	200kA	50kA	4,219	19,550	11,650	20	38
L70QS200	200	700	700	200kA	50kA	5,529	22,067	16,100	22	42
L70QS225	225	700	700	200kA	50kA	9,226	34,900	25,400	22	40
L70QS250	250	700	700	200kA	50kA	10,999	43,750	31,650	27	46
L70QS300	300	700	700	200kA	50kA	16,296	64,400	45,500	31	57
L70QS350	350	700	700	200kA	50kA	24,778	91,500	65,250	35	67
L70QS400	400	700	700	200kA	50kA	34,225	110,667	94,666	41	79
L70QS450	450	700	700	200kA	50kA	38,946	145,500	113,500	45	81
L70QS500	500	700	700	200kA	50kA	42,747	173,000	125,500	56	112
L70QS600	600	700	700	200kA	50kA	67,363	220,333	179,667	67	138
L70QS700	700	700	700	200kA	50kA	99,387	368,000	298,000	72	138
L70QS800	800	700	700	200kA	50kA	156,137	466,333	415,333	76	142

L70QS SERIES HIGH-SPEED ROUND-BODY FUSES

Dimensions Millimeters [inches]

Document Number: OL-L70QS000

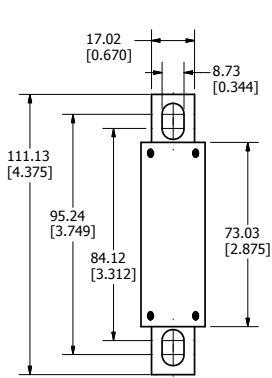

35-100A

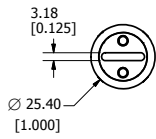

Stud Size: M8 (5/16")
Recommended Torque: 15 Nm (132.76 in-lb)

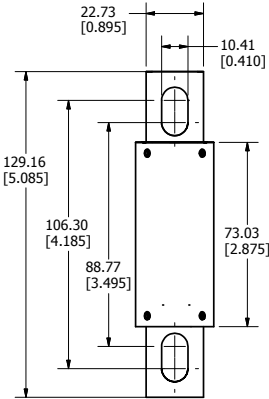

125-200A

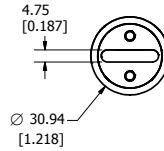

Stud Size: M8 (5/16")
Recommended Torque: 15 Nm (132.76 in-lb)

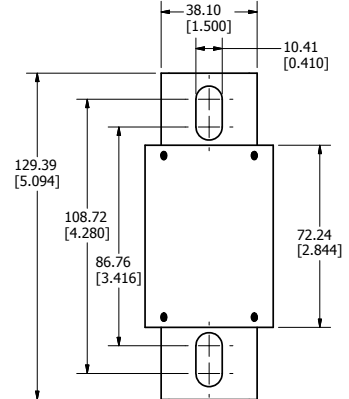

225-400A

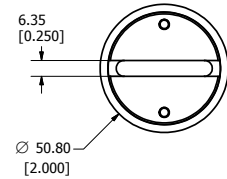

Stud Size: M8 (5/16")
Recommended Torque: 15 Nm (132.76 in-lb)

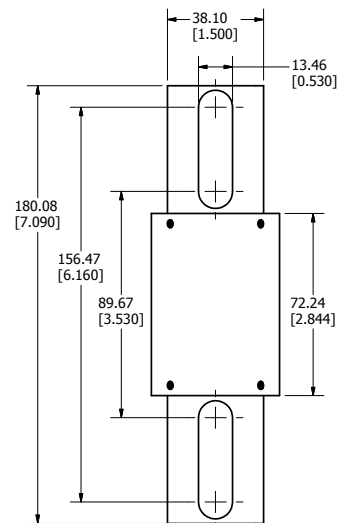

450-600A

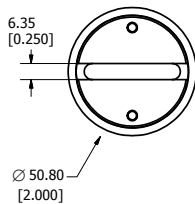

Stud Size: M12 (1/2")
Recommended Torque: 54 Nm (477.94 in-lb)

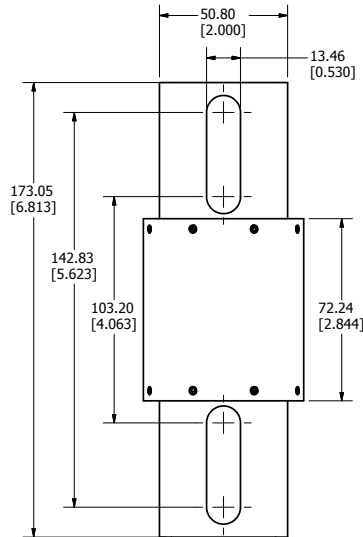

700-800A

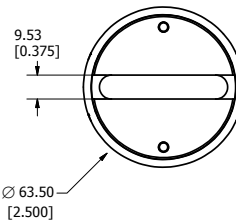

Stud Size: M12 (1/2")
Recommended Torque: 54 Nm (477.94 in-lb)

L50S SERIES HIGH-SPEED FUSE

500 Vac • 450 Vdc • 10-800 A • Traditional Round-Body Style



Specifications

Voltage Rating	500 Vac 450 Vdc
Amperage Rating	10, 12, 15, 20, 25, 30, 35, 40, 50, 60, 70, 80, 90, 100, 125, 150, 175, 200, 225, 250, 275, 300, 350, 400, 450, 500, 550, 600, 700, 800
Interrupting Rating	AC: 200 kAIC DC: 20 kAIC
Material	Body: Melamine Terminals: Copper (silver plated)
Mounting Type	Cylindrical (10 - 30 A) Bolted Tags (35 - 800 A)
Operating Temperature	-55° C to +125° C
Storage Temperature	Up to 35° C with relative humidity less than 65%
Approvals	UL Recognized (File: E71611) CSA Recognized (File: LR29862)
Environmental	RoHS Compliant
Country of Origin	Mexico

Description

Littelfuse L50S Series High-Speed Fuses are designed to protect today's equipment and systems, and are manufactured with Littelfuse-developed technology that sets standards for accuracy, consistent quality, reliability, and predictable performance.

Littelfuse engineers have redefined High-Speed Fuse Technology by using advanced metallurgical, polymer, and materials research, mathematical modeling, and computerized statistical analysis.

Features/Benefits

- Extremely Current Limiting
- Low Watt Losses
- Controlled Transient Over-voltages
- UL Recognized

Applications

- AC & DC Drives
- DC Common Bus Protection
- Power Converters
- UPS
- Soft-Starters

Part Numbering System

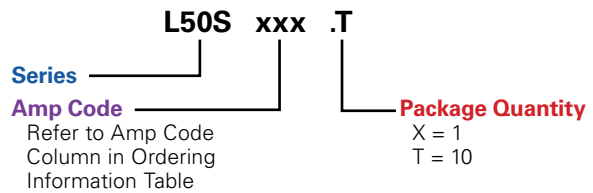

SERIES	AMP	CATALOG NUMBER	ORDERING NUMBER
L50S	10	L50S010	L50S010.T
L50S	500	L50S500	L50S500.X

Recommended Fuse Holder

LSCR001 (35-200 A).....	127
LSCR002 (225-800 A).....	127

Web Resources

Download technical documents: littelfuse.com/L50S

L50S SERIES HIGH-SPEED FUSE

Electrical Specifications

CATALOG NUMBER	AMPERE RATING	VOLTAGE RATING		INTERRUPT RATING		MELTING (PRE-ARC) I ² T (A ² s)	TOTAL CLEARING I ² T (A ² s)			WATTS LOSS AT 100% RATED CURRENT (W)	WATTS LOSS AT 80% RATED CURRENT (W)
		AC	DC	AC	DC		TOTAL CLEARING I ² T (A ² s)				
							100 kA @ 500 Vac	200 kA @ 500 Vac	20 kA @ 450 Vdc		
L50S010	10	500	450	200kA	20kA	21	112	128	85	2	1
L50S012	12	500	450	200kA	20kA	26	149	170	97	2	1
L50S015	15	500	450	200kA	20kA	34	222	250	116	2	2
L50S020	20	500	450	200kA	20kA	48	363	400	143	5	3
L50S025	25	500	450	200kA	20kA	62	528	600	170	7	4
L50S030	30	500	450	200kA	20kA	77	707	820	193	10	5
L50S035	35	500	450	200kA	20kA	130	1,120	1,210	400	6	3
L50S040	40	500	450	200kA	20kA	161	1,420	1,550	525	7	4
L50S050	50	500	450	200kA	20kA	222	2,150	2,360	867	11	6
L50S060	60	500	450	200kA	20kA	259	3,016	3,300	1,287	13	7
L50S070	70	500	450	200kA	20kA	420	4,100	4,930	1,670	17	10
L50S080	80	500	450	200kA	20kA	554	5,300	6,950	2,240	19	10
L50S090	90	500	450	200kA	20kA	677	6,750	9,500	2,900	24	13
L50S100	100	500	450	200kA	20kA	807	8,273	12,600	3,626	30	16
L50S125	125	500	450	200kA	20kA	1,290	13,100	19,000	5,150	22	12
L50S150	150	500	450	200kA	20kA	2,504	19,100	26,500	6,700	27	15
L50S175	175	500	450	200kA	20kA	3,224	26,300	35,000	8,700	33	17
L50S200	200	500	450	200kA	20kA	3,938	34,233	44,583	11,297	35	19
L50S225	225	500	450	200kA	20kA	6,034	43,500	56,000	14,750	31	17
L50S250	250	500	450	200kA	20kA	7,510	54,000	69,000	19,600	36	19
L50S275	275	500	450	200kA	20kA	9,000	65,500	82,000	25,500	41	22
L50S300	300	500	450	200kA	20kA	10,808	78,500	97,500	32,200	42	23
L50S350	350	500	450	200kA	20kA	16,500	107,000	132,000	50,100	50	28
L50S400	400	500	450	200kA	20kA	22,941	142,333	169,667	72,270	58	30
L50S450	450	500	450	200kA	20kA	29,300	178,500	208,000	95,000	58	32
L50S500	500	500	450	200kA	20kA	37,000	220,000	250,000	118,000	64	35
L50S550	550	500	450	200kA	20kA	45,851	311,667	347,333	176,766	75	41
L50S600	600	500	450	200kA	20kA	45,851	311,667	347,333	176,766	98	50
L50S700	700	500	450	200kA	20kA	82,396	460,000	622,333	289,000	96	51
L50S800	800	500	450	200kA	20kA	115,656	647,667	687,500	465,590	118	60

5 High-Speed Fuses

Dimensions

AMPERE RATING	FIGURE NO.	DIMENSIONS INCHES (MM)							
		A	B	C	D	E	F	G	H
10 – 30	1	2 (50.8)	—	½ (12.7)	⅙ (14.3)	—	—	—	—
31 – 60	2	1⅝ (41.3)	2¼ (57.2)	2½ (63.5)	3⅙ (81.0)	1⅜ (20.6)	23/32 (18.3)	1⅓ (8.7)	⅓ (3.2)
61 – 100	3	2⅛ (54.0)	2⅛ (68.3)	3 (76.2)	3⅝ (92.1)	1 (25.4)	.670 (17.0)	1⅓ (8.7)	⅓ (3.2)
101 – 200	3	2⅛ (54.0)	2⅜ (71.4)	2⅝ (74.6)	3⅝ (92.1)	1⅞ (31.0)	.895 (22.7)	5/16 (7.9)	3/16 (4.75)
201 – 400	3	2⅜ (53.2)	2⅝ (70.6)	3⅓ (86.5)	4⅞ (110.3)	1½ (38.1)	1 (25.4)	1⅓ (10.3)	¼ (6.4)
401 – 600	3	2⅜ (56.4)	2⅝ (73.8)	3⅞ (89.7)	4⅞ (113.5)	2 (50.8)	1½ (38.1)	1⅓ (10.3)	¼ (6.4)
601 – 800	3	2⅜ (56.4)	4⅞ (108.7)	4⅝ (117.5)	6⅞ (164.3)	2½ (63.5)	2 (50.8)	1⅞ (13.5)	3/8 (9.5)

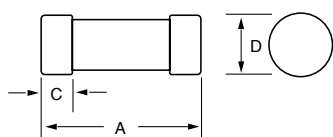

Figure 1

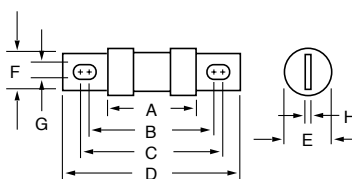

Figure 2

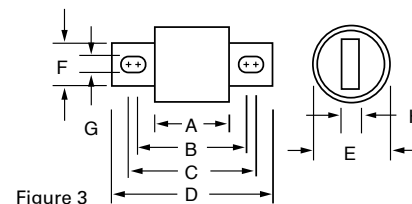

Figure 3

L70S SERIES HIGH-SPEED FUSE

700 Vac • 650 Vdc • 10-800 A • Traditional Round-Body Style



Specifications

Voltage Rating	700 Vac 650 Vdc
Amperage Rating	10, 15, 20, 25, 30, 35, 40, 50, 60, 70, 80, 90, 100, 125, 150, 175, 200, 225, 250, 300, 350, 400, 450, 500, 600, 700, 800
Interrupting Rating	AC: 200 kAIC DC: 20 kAIC
Material	Body: Melamine Terminals: Copper (silver plated)
Mounting Type	Cylindrical (10 - 30 A) Bolted Tags (35 - 800 A)
Operating Temperature	-55° C to +125° C
Storage Temperature	Up to 35° C with relative humidity less than 65%
Approvals	UL Recognized (File: E71611) CSA Recognized (File: LR29862)
Environmental	RoHS Compliant
Country of Origin	Mexico

Description

Littelfuse L70S Series High-Speed Fuses are designed to protect today's equipment and systems, and are manufactured with Littelfuse-developed technology that sets standards for accuracy, consistent quality, reliability, and predictable performance.

Littelfuse engineers have redefined High-Speed Fuse technology by using advanced metallurgical, polymer, and materials research, mathematical modeling, and computerized statistical analysis.

Features/Benefits

- Extremely Current Limiting
- Low Watt Losses
- Controlled Transient Over-voltages
- UL Recognized

Applications

- AC & DC Drives
- DC Common Bus Protection
- Power Converters
- UPS
- Soft-Starters

Part Numbering System

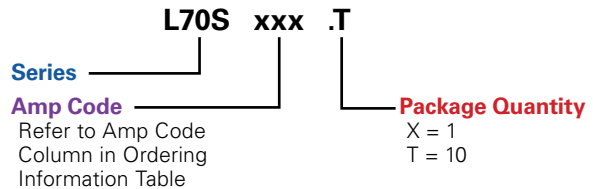

SERIES	AMP	CATALOG NUMBER	ORDERING NUMBER
L70S	10	L70S010	L70S010.T
L70S	500	L70S500	L70S500.X

Recommended Fuse Block

LSCR001 (35-200 A)	127
LSCR002 (225-800 A)	127

Web Resources

Download technical documents: littelfuse.com/L70S

L70S SERIES HIGH-SPEED FUSE

Electrical Specifications

CATALOG NUMBER	AMPERE RATING	VOLTAGE RATING		INTERRUPT RATING		MELTING (PRE-ARC) I ² T (A ² s)	TOTAL CLEARING I ² T (A ² s)	TOTAL CLEARING I ² T (A ² s)	TOTAL CLEARING I ² T (A ² s)	WATTS LOSS AT 100% RATED CURRENT (W)	WATTS LOSS AT 80% RATED CURRENT (W)
		AC	DC	AC	DC		100 kA @ 700 Vac	200 kA @ 700 Vac	20 kA @ 650 Vdc		
L70S010	10	700	650	200kA	20kA	21	160	173	346	2	1
L70S015	15	700	650	200kA	20kA	34	330	355	270	2	2
L70S020	20	700	650	200kA	20kA	48	550	599	300	5	2
L70S025	25	700	650	200kA	20kA	62	810	900	340	7	4
L70S030	30	700	650	200kA	20kA	77	1,130	1,220	417	10	5
L70S035	35	700	650	200kA	20kA	110	1,470	1,500	500	12	6
L70S040	40	700	650	200kA	20kA	150	1,830	2,000	660	13	7
L70S050	50	700	650	200kA	20kA	250	2,670	3,200	1,070	16	9
L70S060	60	700	650	200kA	20kA	380	3,646	4,674	1,572	18	9
L70S070	70	700	650	200kA	20kA	545	4,800	6,000	1,970	16	9
L70S080	80	700	650	200kA	20kA	745	6,180	7,550	2,380	21	11
L70S090	90	700	650	200kA	20kA	990	7,650	9,250	2,830	25	13
L70S100	100	700	650	200kA	20kA	1,266	9,407	11,117	3,266	29	14
L70S125	125	700	650	200kA	20kA	2,150	14,700	17,550	4,900	33	17
L70S150	150	700	650	200kA	20kA	3,280	21,250	25,700	6,800	51	24
L70S175	175	700	650	200kA	20kA	4,700	28,750	34,800	9,000	63	28
L70S200	200	700	650	200kA	20kA	6,411	37,300	45,583	11,447	75	33
L70S225	225	700	650	200kA	20kA	8,000	46,500	57,000	16,000	43	24
L70S250	250	700	650	200kA	20kA	9,900	58,000	69,500	22,000	49	27
L70S300	300	700	650	200kA	20kA	14,000	83,000	97,700	37,500	60	33
L70S350	350	700	650	200kA	20kA	19,000	113,000	131,000	59,000	71	36
L70S400	400	700	650	200kA	20kA	24,373	147,290	169,000	87,875	107	49
L70S450	450	700	650	200kA	20kA	33,000	191,000	219,000	119,000	85	47
L70S500	500	700	650	200kA	20kA	44,200	240,000	275,000	155,000	92	49
L70S600	600	700	650	200kA	20kA	72,000	370,250	405,000	246,182	106	56
L70S700	700	700	650	200kA	20kA	110,000	526,000	573,000	255,000	128	67
L70S800	800	700	650	200kA	20kA	157,082	735,330	762,333	262,949	156	78

5 High-Speed Fuses

Dimensions

AMPERE RATING	FIGURE NO.	DIMENSIONS INCHES (MM)									
		A	B	C	D	E	F	G	H	J	
10 – 30	1	2 (50.8)	—	½ (12.7)	¼ (6.3)	—	—	—	—	—	—
31 – 60	2	2 7/8 (73.0)	3 1/16 (87.3)	3 3/4 (95.2)	4 3/8 (111.1)	1 (25.4)	43/64 (17.1)	1 1/32 (8.7)	1/8 (3.2)	—	
61 – 100	2	2 7/8 (73.0)	3 9/16 (90.5)	3 11/16 (93.7)	4 3/8 (111.1)	1 1/32 (31.0)	29/32 (22.9)	5/16 (7.9)	3/16 (4.8)	—	
101 – 200	2	2 27/32 (72.2)	3 17/32 (89.7)	4 5/32 (105.6)	5 3/32 (129.4)	1 1/2 (38.1)	1 (25.4)	1 3/32 (10.3)	1/4 (6.4)	—	
201 – 400	2	2 27/32 (72.2)	3 17/32 (89.7)	4 5/32 (105.6)	5 3/32 (129.4)	2 (50.8)	1 1/2 (38.1)	1 3/32 (10.3)	1/4 (6.4)	—	
401 – 600	2	2 27/32 (72.2)	4 29/32 (124.6)	5 1/4 (133.4)	7 3/32 (180.2)	2 1/2 (63.5)	2 (50.8)	1 7/32 (13.5)	3/8 (9.5)	—	
601 – 800	3	3 1/16 (84.1)	5 5/16 (134.9)	6 13/16 (173.0)	—	2 7/8 (73.0)	2 (50.8)	5/8 (15.9)	3/8 (9.5)	5/16 (7.9)	

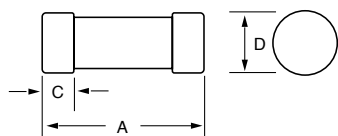

Figure 1

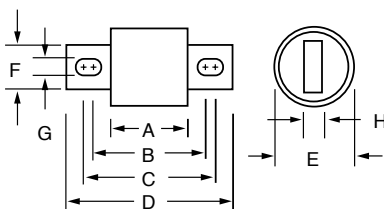

Figure 2

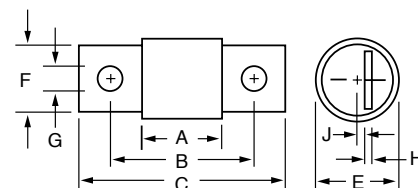

Figure 3

TRADITIONAL HIGH-SPEED FUSES

150/250/600 Vac • Very Fast-Acting • 1-1200 A



Specifications

Voltage Ratings

L15S:	150 Vac/dc (1 – 60 A) 150 Vac (70 – 1000 A) 100 Vdc (70 – 1000 A)
L25S:	250 Vac/dc (1 – 200 A) 250 Vac (225 – 800 A) 200 Vdc (225 – 800 A) L25S series fuses are Littelfuse Certified for DC ratings shown in Rating Table.
L60S:	600 Vac
OKLC:	600 Vac

Interrupting Rating

AC:	200 kA rms (L15S series 100 kA)
DC:	20 kA
Ampere Range	1 - 1000A (See Ordering Information Table for ratings available in each series)

Approvals

UL Recognized (File: E71611)
CSA Recognized (File: LR29862)

Part Numbering System

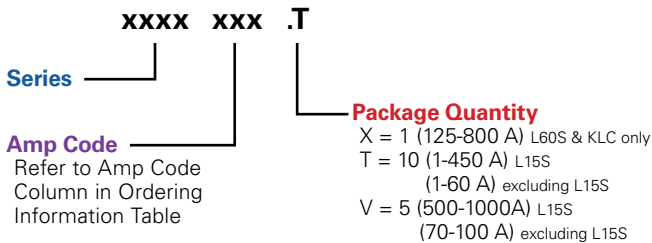

Recommended Fuse Holders

1LFS101/1LFS102.....	129
LSCR001/LSCR002.....	127

Web Resources

For additional information, visit: littelfuse.com/high-speed

Note: High-Speed fuses are designed for fixed installations. They are not intended for use in moving vehicle applications.

Ordering Information

AMP CODE	SERIES ORDERING NUMBER			
	L15S	L25S	L60S	OKLC†
001	L15S001	L25S001	L60S001	OKLC001
002	L15S002	L25S002	L60S002	OKLC002
003	L15S003	L25S003	L60S003	OKLC003
004	L15S004	L25S004	L60S004	OKLC004
005	L15S005	L25S005	L60S005	OKLC005
006	L15S006	L25S006	L60S006	OKLC006
007	L15S007	—	—	OKLC007
008	L15S008	L25S008	L60S008	OKLC008
009	L15S009	—	—	—
010	L15S010	L25S010	L60S010	OKLC010
012	L15S012	L25S012	L60S012	OKLC012
015	L15S015	L25S015	L60S015	OKLC015
17.5	—	—	L60S17.5	OKLC17.5
020	L15S020	L25S020	L60S020	OKLC020
025	L15S025	L25S025	L60S025	OKLC025
030	L15S030	L25S030	L60S030	OKLC030
035	L15S035	L25S035	L60S035	OKLC035
040	L15S040	L25S040	L60S040	OKLC040
045	L15S045	L25S045	L60S045	OKLC045
050	L15S050	L25S050	L60S050	OKLC050
060	L15S060	L25S060	L60S060	OKLC060
070	L15S070	L25S070	L60S070	OKLC070
080	L15S080	L25S080	L60S080	OKLC080
090	L15S090	L25S090	L60S090	OKLC090
100	L15S100	L25S100	L60S100	OKLC100
110	—	—	—	OKLC110
125	L15S125	L25S125	L60S125	OKLC125
150	L15S150	L25S150	L60S150	OKLC150
175	—	L25S175	L60S175	OKLC175
200	L15S200	L25S200	L60S200	OKLC200
225	—	L25S225	L60S225	OKLC225
250	L15S250	L25S250	L60S250	OKLC250
275	—	L25S275	—	—
300	L15S300	L25S300	L60S300	OKLC300
350	L15S350	L25S350	L60S350	OKLC350
400	L15S400	L25S400	L60S400	OKLC400
450	L15S450	L25S450	L60S450	OKLC450
500	L15S500	L25S500	L60S500	OKLC500
550	—	—	—	—
600	L15S600	L25S600	L60S600	OKLC600
700	—	L25S700	L60S700	OKLC700
800	L15S800	L25S800	L60S800	OKLC800
1000	L15S1000	—	—	—

† OKLC series fuses are recommended for replacement use only.

TRADITIONAL HIGH-SPEED FUSES

Dimensions

AMPERE RATING	FIG. NO.	DIMENSIONS INCHES (MM)							
		A	B	C	D	E	F	G	H
L15S Series, 150 Vac									
1 – 30	1	1½ (38.1)	—	¾ (9.5)	13/32 (10.3)	—	—	—	—
31 – 60	1	2 (50.8)	—	5/8 (15.9)	13/16 (20.6)	—	—	—	—
61 – 450	3	15/32 (29.4)	17/8 (47.6)	23/16 (55.6)	221/32 (67.5)	1 (25.4)	43/64 (17.1)	5/16 (7.9)	3/16 (4.8)
451 – 1000	3	1¼ (31.8)	115/16 (49.2)	29/16 (65.1)	3½ (88.9)	1½ (38.1)	1 (25.4)	13/32 (10.3)	¼ (6.4)
L25S Series, 250 Vac									
1 – 30	1	2 (50.8)	—	½ (12.7)	9/16 (14.3)	—	—	—	—
31 – 60	2	15/8 (41.3)	2¼ (57.2)	2½ (63.5)	33/16 (81.0)	19/16 (20.6)	23/32 (18.3)	11/32 (8.7)	1/8 (3.2)
61 – 200	3	15/8 (41.3)	25/16 (58.7)	27/16 (61.9)	31/8 (79.4)	17/32 (31.0)	1 (25.4)	5/16 (7.9)	3/16 (4.8)
201 – 700	3	119/32 (40.5)	29/32 (57.9)	229/32 (73.8)	327/32 (97.6)	1½ (38.1)	1 (25.4)	13/32 (10.3)	¼ (6.4)
701 – 800	3	119/32 (40.5)	29/32 (57.9)	229/32 (73.8)	327/32 (97.6)	2 (50.8)	1½ (38.1)	13/32 (10.3)	¼ (6.4)
L60S Series, 600 Vac									
1 – 30	1	5 (127.0)	—	5/8 (15.9)	13/16 (20.6)	—	—	—	—
31 – 60	2	225/32 (70.6)	37/16 (87.3)	311/16 (93.7)	43/8 (111.1)	13/16 (20.6)	23/32 (18.3)	11/32 (8.7)	1/8 (3.2)
61 – 100	2	229/32 (73.8)	317/32 (89.7)	325/32 (96.0)	415/32 (113.5)	11/16 (27.0)	23/32 (18.3)	11/32 (8.7)	1/8 (3.2)
101 – 200	2	229/32 (73.8)	331/16 (90.5)	3¾ (95.3)	413/32 (111.9)	15/16 (33.3)	1 (25.4)	5/16 (7.9)	3/16 (4.8)
201 – 400	2	229/32 (73.8)	331/32 (100.8)	453/32 (105.6)	51/8 (130.2)	137/64 (40.1)	1 (25.4)	13/32 (10.3)	¼ (6.4)
401 – 600	2	27/8 (73.0)	331/32 (100.8)	49/64 (105.2)	51/8 (130.2)	21/16 (52.8)	1½ (38.1)	13/32 (10.3)	¼ (6.4)
601 – 800	2	31/32 (77.0)	55/32 (133.4)	511/32 (135.7)	7¼ (184.2)	2½ (63.5)	2 (50.8)	17/32 (13.5)	3/8 (9.5)
KLC Series, 600 Vac									
1 – 30	2	17/8 (47.6)	2½ (63.5)	—	27/8 (73.0)	9/16 (14.3)	13/32 (10.3)	¼ (6.4)	3/64 (1.2)
31 – 60	2	2¾ (69.9)	33/8 (85.7)	35/8 (92.1)	45/16 (109.5)	13/16 (20.6)	23/32 (18.3)	11/32 (8.7)	1/8 (3.2)
61 – 100	3	27/8 (73.0)	321/32 (92.9)	41/16 (103.2)	5 (127.0)	1 (25.4)	¾ (19.1)	13/32 (10.3)	1/8 (3.2)
101 – 200	3	227/32 (72.2)	317/32 (89.7)	43/8 (111.1)	53/32 (129.4)	1½ (38.1)	1 (25.4)	13/32 (10.3)	¼ (6.4)
201 – 400	3	227/32 (72.2)	421/32 (118.3)	427/32 (123.0)	6¼ (158.8)	2 (50.8)	15/8 (41.3)	9/16 (14.3)	¼ (6.4)
401 – 800	3	227/32 (72.2)	421/32 (118.3)	511/32 (135.7)	6¼ (158.8)	2½ (63.5)	2 (50.8)	9/16 (14.3)	3/8 (9.5)

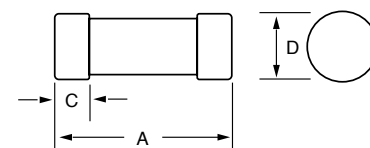

Fig. 1

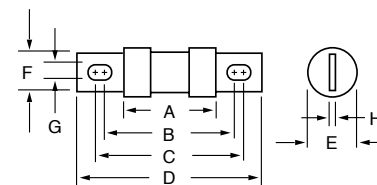

Fig. 2

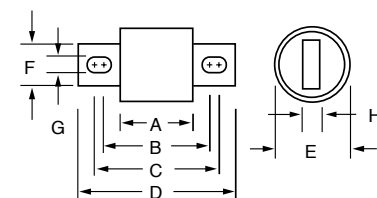

Fig. 3

Section Overview

Littelfuse® offers a wide variety of open-face and dead-front fuse blocks, in addition to a variety of in-line fuse holders, distribution/splicer blocks, fuse pullers and accessories.



BLOCKS AND HOLDERS

Table of Contents

LF Series Fuse Blocks Overview	89
Class J Fuse Blocks.....	91
Class R and H/K5 Fuse Blocks	94
Class T Fuse Blocks	100
Class G Fuse Blocks.....	105
Class CC/CD and Midget Fuse Blocks	107
LF Series Fuse Block Covers	112
Solar Rated Fuse Blocks	113
Dead Front Fuse Holders	119
Miscellaneous Fuse Blocks and Holders	120
High-Speed Fuse Blocks	128
Distribution and Splicer Blocks	131
In-Line Fuse Holders.....	149

FUSE BLOCK OVERVIEW



Description

Littelfuse offers a comprehensive line of fuse blocks that incorporate many benefits such as indication, snap to-release, DIN-Rail mounting and universal mounting holes.

New Options Available

- Reduced Footprint—Save space with designs up to 35% smaller in width
- Indication—Increase safety and reduce downtime with built-in local indication
- Universal Mounting Holes—Simplify replacement with universal mounting options
- DIN Rail Mountable—Ease installation with a 35 mm hat DIN Rail mounting option
- One-Hand Release—Save time by using only one hand for a simple release from DIN Rail

Fuse Block Selection

The following guidelines should help simplify the selection of proper fuse blocks:

- 1. Determine the system voltage**—Since fuses are selected on the basis of system voltage, fuse blocks are selected to match the voltage rating of the fuse.
- 2. Determine the design short-circuit current**—If available short-circuit current cannot be determined, or if it will vary with equipment location, select fuses with a 200,000 ampere interrupting rating (A.I.R.) and mating fuse blocks with a withstand rating of 200,000 amperes for maximum safety.
- 3. Determine the type and ampere rating of the fuse to be used**—The fuse ampere rating, opening characteristics (fast acting or time-delay) and size are important considerations in fuse selection. Fuse blocks may be used with a fuse rated at the corresponding ampere rating or below. For example, a fuse block rated at 30 amperes may be used with a fuse rated from 0 to 30 amperes.
- 4. Determine if NEC®, CSA, UL, or other requirements are applicable**—Any of these requirements should be obtained from the approving agency in advance of fuse and fuse block selection.

5. Select the type of wire termination

Three types of wire termination are available:

- Screw*—for use with spade lugs or ring terminals
- Screw with Pressure Plate*—for use with solid or stranded wire without terminal. Recommended where vibration will be a factor
- Box Lug—for use with all types of solid wire and Class B and Class C stranded wire. The most durable, but not for use with welding cable or other rope-stranded conductors.

*1/4" Quick Connect terminals are available on the Midget and Class CC fuse blocks.

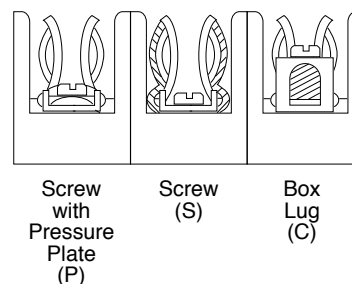

6. Decide on the number of poles in each block—The number of poles for each set of fuses is determined by the characteristics of the circuit.

7. Determine if block should be DIN Rail mounted—Many of the new Littelfuse fuse blocks are DIN Rail mountable. Be sure to look to corresponding ordering tables to match the correct part number on the following product pages.

8. Determine if fuse clips need to be reinforced
Fuse clips may have a tendency to lose some of their tension over a period of time. This may be prevented by specifying reinforced fuse clips.

Ordering Information

The Littelfuse fuse block part number consists of the below skeleton. Please refer to UL Class Tables for specific information.

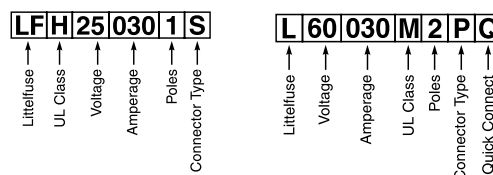

***For all Class R, H, J, G and T Fuse blocks**

For all Class CC, and Midget-Style

†These new fuse blocks replace previous Littelfuse fuse blocks that had very similar part numbers for customer convenience. The only change is an "F" has been added as the second character in the new block part numbers.

Caution: Littelfuse indicating fuse blocks are intended to quickly identify open fuses while power is still applied. Only qualified electrically trained technicians should replace fuses and follow standard OSHA and NFPA 70E safe work practices, such as Lock-Out and Tag-Out procedures and verification before replacing any fuses in indicating fuse blocks.

LF SERIES INDICATING FUSE BLOCKS



Smaller Footprint Provides Space Savings



DIN-Rail Mounting Eases Installation



Indication Improves Functionality

An Indication of Value

The Littelfuse LF Series Fuse Blocks and Covers offer generous space savings and a greater value over previous generations. View the different series classes for available indication, snap-to-release DIN rail mounting, universal mounting holes and touch-safe covers.

LF SERIES CLASS J FUSE BLOCKS

600 V



Patent
US8810420



Description

The Littelfuse 600 V Class J blocks offer generous space savings and enhanced value over previous generations, such as indication, snap-to-release DIN-rail mounting and universal mounting holes.

Features/Benefits

- Space-saving design – up to 45% smaller
- Universal mounting holes for easy replacement
- Indication offered on all versions except 200–600 A
- One hand release from DIN rail for ferrule style fuses
- Reinforced fuse clips are standard on all Class J blocks
- Covers available for 100 A and lower to enhance safety
- Both hex and slot set screw options available on 30A and 60A box lugs

Specifications

Voltage Ratings	600 V
Ampere Ratings	0 – 600 A
Leakage Current	<0.6 mA at 600 V
Flammability Rating	UL94 V-0
Approvals	UL Listed (File: E14721) CSA Certified (File: LR7316)
Environmental	RoHS Compliant, Lead (Pb) Free REACH Compliant

Recommended Fuses

Time Delay
Series: JTD_ID
Series: JTD

Fast Acting
Series: JLS

For information about Touch-Safe Class J fuse holders:
Littelfuse.com/lfpsj

Web Resources

Sample requests, downloadable CAD drawings, fuse block cover datasheet and other technical information:
Littelfuse.com/fuseblocks
Littelfuse.com/lfj

Ordering Information (Class J 600 V)

AMP RATING	POLES	ORDERING NUMBER					TORQUE	TERMINAL	WIRE RANGE	WIRE TYPE	BASE TEMP RATING	DIN RAIL	INDICATION	COVER ORDERING NUMBER*	
		BASE PART NUMBER	TERMINAL SUFFIX												
			BOX LUG HEX	BOX LUG SLOT	PRESSURE PLATE	SCREW									
30	1	LFJ600301	CID-HX	CID	PID	SID	2.8 N-m (25 in-lbs)	C	6-14 AWG	CU Only	125°C	•	•	LFJ60030FBC	
	2	LFJ600302	CID-HX	CID	PID	SID		P	10-14 AWG						
	3	LFJ600303	CID-HX	CID	PID	SID		S	10-22 AWG						
60	1	LFJ600601	CID-HX	CID	—	—	5.6 N-m (50 in-lbs)	2-4 AWG		CU-AL	125°C	•	•	LFJ60060FBC	
	2	LFJ600602	CID-HX	CID	—	—		6-14 AWG							
	3	LFJ600603	CID-HX	CID	—	—		6-14 AWG							
100	1	LFJ601001	C	—	—	—	13.6 N-m (120 in-lbs)	2/0-6 AWG		CU-AL	130°C	—	•	LFJ60100FBC	
	3	LFJ601003	C	—	—	—		4.5 N-m (40 in-lbs)							8 AWG
								4.0 N-m (35 in-lbs)							
200	1	LFJ602001	C	—	—	—	31.1 N-m (275 in-lbs)	250 kcmil-6		CU-AL	130°C	—	—	—	
	3	LFJ602003	C	—	—	—		250 kcmil-6							
400	1	LFJ604001	C	—	—	—	31.1 N-m (275 in-lbs)	(2) 350 kcmil-1/0		CU-AL	130°C	—	—	—	
	3	LFJ604003	C	—	—	—		(2) 350 kcmil-1/0							
600	1	LFJ606001	C	—	—	—	42.4 N-m (375 in-lbs)	(2) 500 kcmil-4		CU-AL	130°C	—	—	—	
	3	LFJ606003	C	—	—	—		(2) 500 kcmil-4							

Note: Reinforcing springs standard on all Class J fuse blocks.
*Covers sold individually. One cover needed for each pole.

CLASS J FUSE BLOCK DIMENSIONS

Dimensions mm (inches)

600 V 30 A

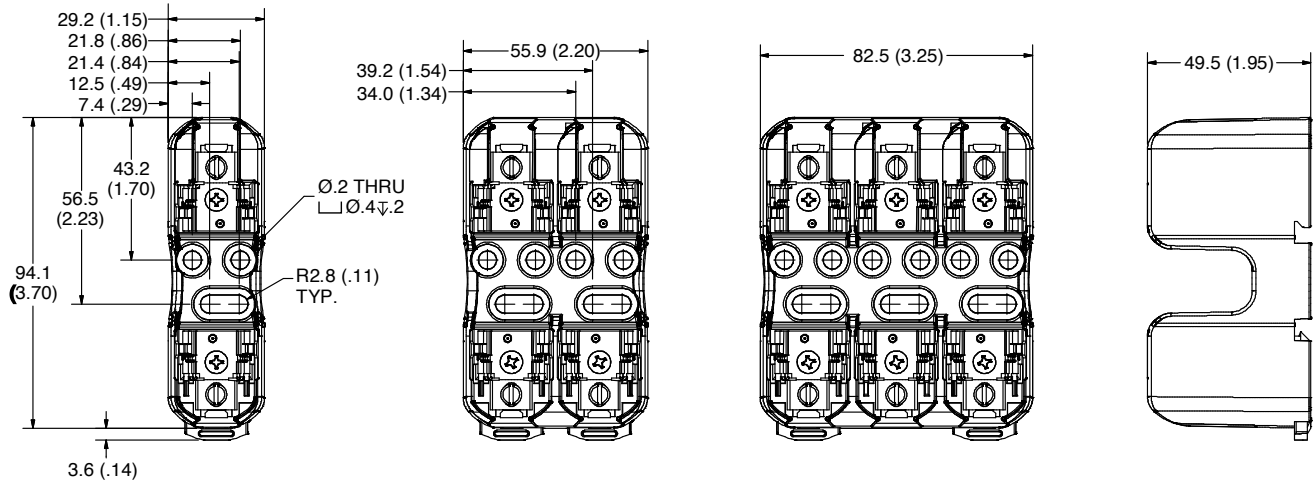

600 V 60 A

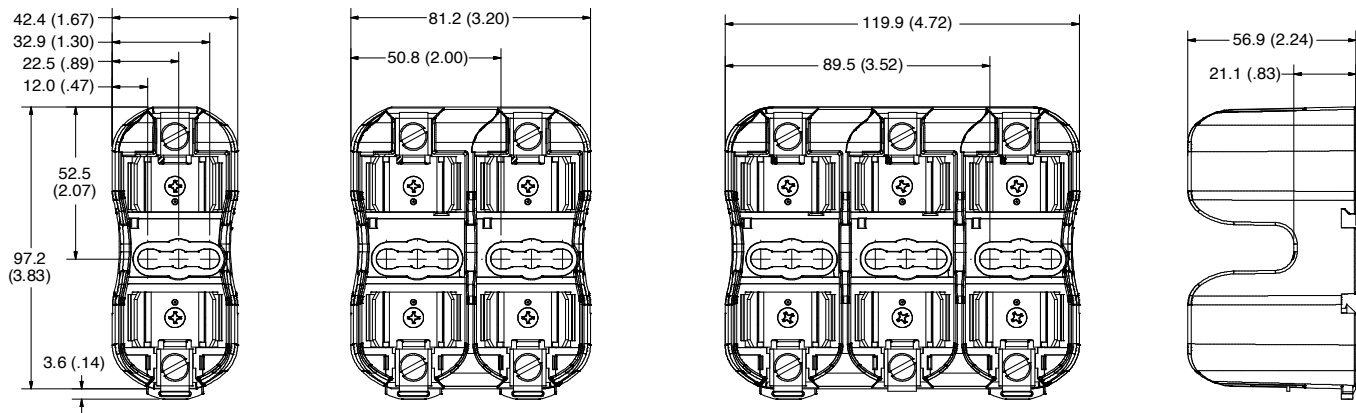

600 V 100 A

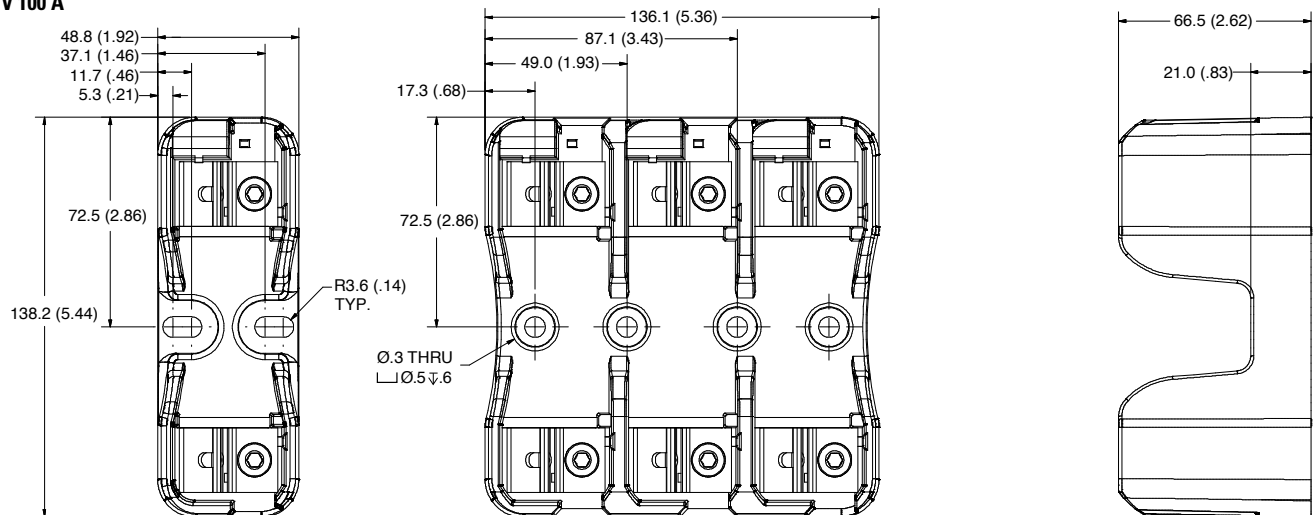

CLASS J FUSE BLOCK DIMENSIONS

Dimensions mm (inches)

600 V 200 A

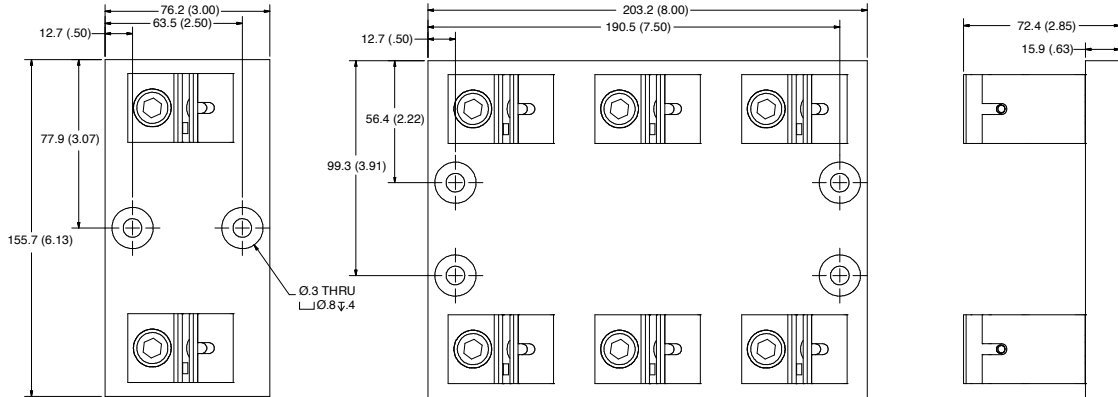

600 V 400 A

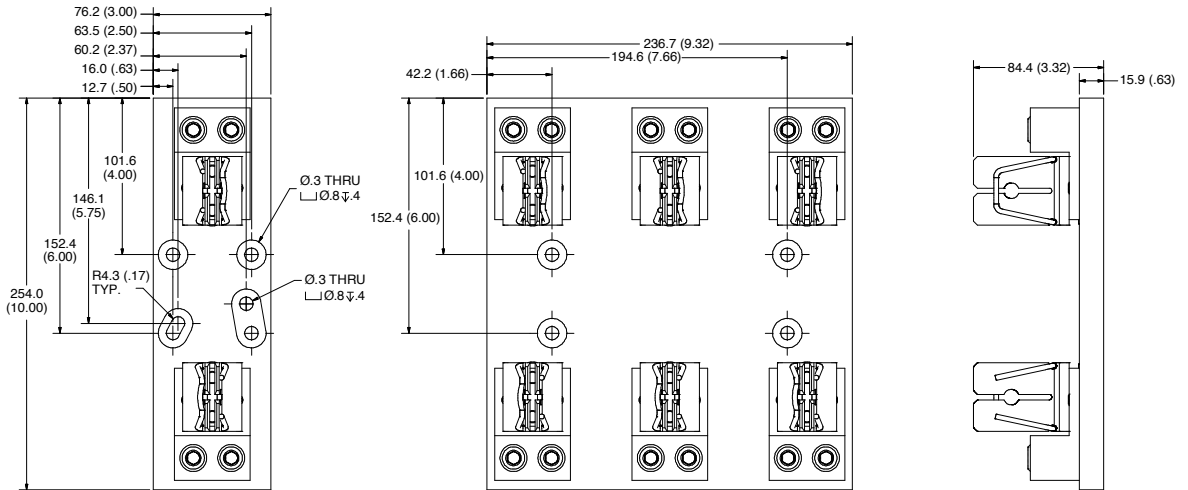

600 V 600 A

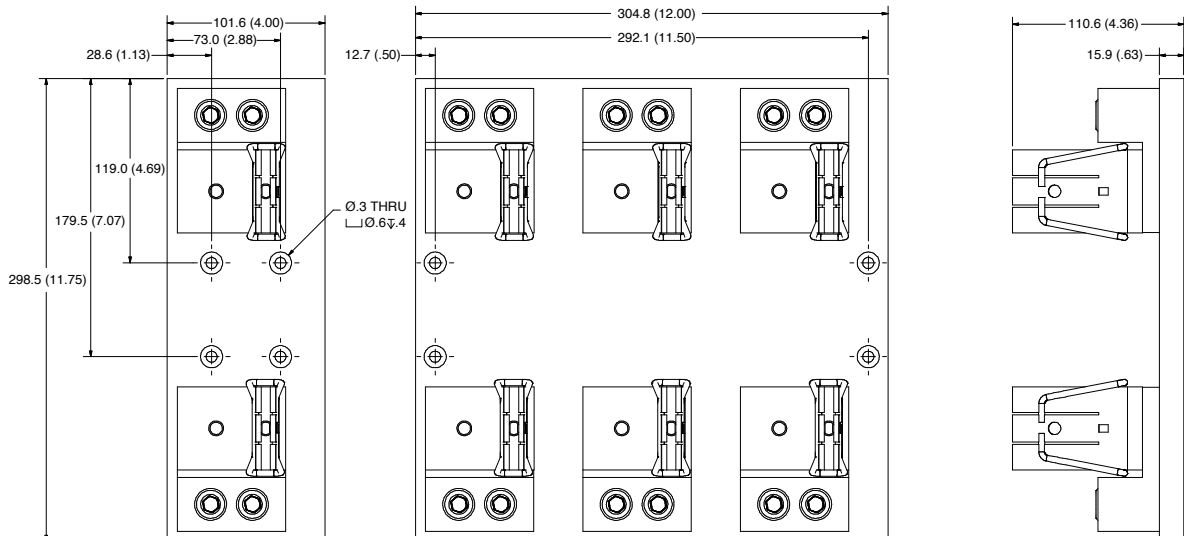

LF SERIES CLASS R & H/K5 FUSE BLOCKS

250 V • 600 V



Description

The Littelfuse Class R and H/K5 blocks offer many benefits such as indication, snap-to-release DIN rail mounting and universal mounting holes. Class H and Class R fuse blocks are dimensionally the same, but Class R blocks incorporate a rejection feature, which only allows Class R fuses to be inserted.

Features/Benefits

- Universal mounting holes for easy replacement
- Indication offered on most 250 V and 600 V versions
- One hand release from DIN rail for ferrule style fuses
- Reinforced fuse clips are standard on all Class H and Class R fuse blocks
- Covers available for 100 A and lower to enhance safety

Web Resources

Download CAD drawings, fuse block cover datasheet and other technical information: littelfuse.com/lfr
littelfuse.com/lfh

Specifications

Voltage Rating	250 V, 600 V
Ampere Ratings	0-600 A
Leakage Current	<0.6 mA at 600 V
Withstand Rating	Class H: 10 kA RMS SYM Class R: 200 kA RMS SYM
Flammability Rating	UL94 V-0
Approvals	UL Listed (File: E14721) CSA Certified (File: LR7316)
Environmental	RoHS Compliant, Lead (Pb) Free

Recommended Fuses

250 V – Class R Blocks

LLNRK	13
KLNR	15
FLNR/FLNR_ID	17

250 V – Class H / K5 Blocks

NLN	20
-----------	----

600 V – Class R Blocks

LLSRK/LLSRK_ID	13
KLSR	15
IDSR	16
FLSR/FLSR_ID	17

600 V – Class H / K5 Blocks

NLS	20
-----------	----

Ordering Information (Class H 250 V)

AMP RATING	POLES	ORDERING NUMBER			TORQUE	TERMINAL	WIRE RANGE	WIRE TYPE	BASE TEMP RATING	DIN RAIL	INDICATION	COVER ORDERING NUMBER*
		BASE PART NUMBER	BOX LUG	SUFFIX PRESSURE PLATE								
30	1	LFH250301	C	P	2.8 N-m (25 in-lbs)	C	6-14 AWG	CU Only	125°C	•	—	LFH25030FBC
	2	LFH250302	C	P		P	10-14 AWG					
	3	LFH250303	C	P		S	10-22 AWG					
60	1	LFH250601	CID	—	5.6 N-m (50 in-lbs)	—	2-4 AWG	CU-AL	125°C	•	•	LFH25060FBC
	2	LFH250602	CID	—		2.8 N-m (25 in-lbs)	6-14 AWG					
	3	LFH250603	CID	—								
100	1	LFH251001	CID	—	13.6 N-m (120 in-lbs)	—	2/0-6 AWG	CU-AL	130°C	—	•	LFH25100FBC
	3	LFH251003	CID	—		4.5 N-m (40 in-lbs)	8 AWG					
	—	—	—	—		4.0 N-m (35 in-lbs)	10-14 AWG					
200	1	LFH252001	C	—	31.1 N-m (275 in-lbs)	—	250 kcmil-6	CU-AL	130°C	—	—	—
	3	LFH252003	C	—								
400	1	LFH254001	C	—	31.1 N-m (275 in-lbs)	—	(2) 350 kcmil-1/0	CU-AL	130°C	—	—	—
	3	LFH254003	C	—								
600	1	LFH256001	C	—	42.4 N-m (375 in-lbs)	—	(2) 500 kcmil-4	CU-AL	130°C	—	—	—
	3	LFH256003	C	—								

Note: Reinforcing springs standard on all Class H fuse blocks.

*Covers sold individually. One cover needed for each pole.

LF SERIES CLASS R & H/K5 FUSE BLOCKS

Ordering Information (Class H 600 V)

AMP RATING	POLES	ORDERING NUMBER				TORQUE	TERMINAL	WIRE RANGE	WIRE TYPE	BASE TEMP RATING	SNAP TO RELEASE	INDICATION	COVER ORDERING NUMBER*
		BASE ORDERING NUMBER	BOX LUG	SUFFIX PRESSURE PLATE	SCREW								
30	1	LFH600301	CID	PID	SID	2.8 N-m (25 in-lbs)	C	6-14 AWG	CU Only	130°C	•	•	LFH60030FBC
	2	LFH600302	CID	PID	SID		P	10-14 AWG					
	3	LFH600303	CID	PID	SID		S	10-22 AWG					
60	1	LFH600601	CID	—	—	5.6 N-m (50 in-lbs)	2-4 AWG		CU-AL	130°C	•	•	LFH60060FBC
	2	LFH600602	CID	—	—		6-14 AWG						
	3	LFH600603	CID	—	—		2.8 N-m (25 in-lbs)						
100	1	LFH601001	CID	—	—	13.6 N-m (120 in-lbs)	2/0-6 AWG		CU-AL	130°C	—	•	LFH60100FBC
	3	LFH601003	CID	—	—		4.5 N-m (40 in-lbs)						
	3	LFH601003	CID	—	—		4.0 N-m (35 in-lbs)						
200	1	LFH602001	C	—	—	31.1 N-m (275 in-lbs)	250 kcmil-6		CU-AL	130°C	—	—	—
	3	LFH602003	C	—	—		10-14 AWG						
400	1	LFH604001	C	—	—	31.1 N-m (275 in-lbs)	(2) 350 kcmil-1/0		CU-AL	130°C	—	—	—
	3	LFH604003	C	—	—		10-14 AWG						
600	1	LFH606001	C	—	—	42.4 N-m (375 in-lbs)	(2) 500 kcmil-4		CU-AL	130°C	—	—	—
	3	LFH606003	C	—	—		10-14 AWG						

Note: Reinforcing springs standard on all Class H fuse blocks.

Ordering Information (Class R 250 V)

AMP RATING	POLES	ORDERING NUMBER				TORQUE	TERMINAL	WIRE RANGE	WIRE TYPE	BASE TEMP RATING	SNAP TO RELEASE	INDICATION	COVER ORDERING NUMBER*
		BASE ORDERING NUMBER	BOX LUG	SUFFIX PRESSURE PLATE	SCREW								
30	1	LFR250301	C	P	S	2.8 N-m (25 in-lbs)	C	6-14 AWG	CU Only	125°C	•	—	LFH25030FBC
	2	LFR250302	C	P	S		P	10-14 AWG					
	3	LFR250303	C	P	S		S	10-22 AWG					
60	1	LFR250601	CID	—	—	5.6 N-m (50 in-lbs)	2-4 AWG		CU-AL	125°C	•	•	LFH25060FBC
	2	LFR250602	CID	—	—		6-14 AWG						
	3	LFR250603	CID	—	—		13.6 N-m (120 in-lbs)						
100	1	LFR251001	CID	—	—	13.6 N-m (120 in-lbs)	2/0-6 AWG		CU-AL	130°C	—	•	LFH25100FBC
	3	LFR251003	CID	—	—		4.5 N-m (40 in-lbs)						
	3	LFR251003	CID	—	—		4.0 N-m (35 in-lbs)						
200	1	LFR252001	C	—	—	31.1 N-m (275 in-lbs)	250 kcmil-6		CU-AL	130°C	—	—	—
	3	LFR252003	C	—	—		10-14 AWG						
400	1	LFR254001	C	—	—	31.1 N-m (275 in-lbs)	(2) 350 kcmil-1/0		CU-AL	130°C	—	—	—
	3	LFR254003	C	—	—		10-14 AWG						
600	1	LFR256001	C	—	—	42.4 N-m (375 in-lbs)	(2) 500 kcmil-4		CU-AL	130°C	—	—	—
	3	LFR256003	C	—	—		10-14 AWG						

Note: Reinforcing springs standard on all Class R fuse blocks.

Ordering Information (Class R 600 V)

AMP RATING	POLES	ORDERING NUMBER				TORQUE	TERMINAL	WIRE RANGE	WIRE TYPE	BASE TEMP RATING	SNAP TO RELEASE	INDICATION	COVER ORDERING NUMBER*
		BASE ORDERING NUMBER	BOX LUG	SUFFIX PRESSURE PLATE	SCREW								
30	1	LFR600301	CID	PID	SID	2.8 N-m (25 in-lbs)	C	6-14 AWG	CU Only	130°C	•	•	LFH60030FBC
	2	LFR600302	CID	PID	SID		P	10-14 AWG					
	3	LFR600303	CID	PID	SID		S	10-22 AWG					
60	1	LFR600601	CID	—	—	5.6 N-m (50 in-lbs)	2-4 AWG		CU-AL	130°C	•	•	LFH60060FBC
	2	LFR600602	CID	—	—		6-14 AWG						
	3	LFR600603	CID	—	—		2.8 N-m (25 in-lbs)						
100	1	LFR601001	CID	—	—	13.6 N-m (120 in-lbs)	2/0-6 AWG		CU-AL	130°C	—	•	LFH60100FBC
	3	LFR601003	CID	—	—		4.5 N-m (40 in-lbs)						
	3	LFR601003	CID	—	—		4.0 N-m (35 in-lbs)						
200	1	LFR602001	C	—	—	31.1 N-m (275 in-lbs)	250 kcmil-6		CU-AL	130°C	—	—	—
	3	LFR602003	C	—	—		10-14 AWG						
400	1	LFR604001	C	—	—	31.1 N-m (275 in-lbs)	(2) 350 kcmil-1/0		CU-AL	130°C	—	—	—
	3	LFR604003	C	—	—		10-14 AWG						
600	1	LFR606001	C	—	—	42.4 N-m (375 in-lbs)	(2) 500 kcmil-4		CU-AL	130°C	—	—	—
	3	LFR606003	C	—	—		10-14 AWG						

Note: Reinforcing springs standard on all Class R fuse blocks.

*Covers sold individually. One cover needed for each pole.

LF SERIES CLASS R & H/K5 FUSE BLOCKS

Dimensions mm (inches)

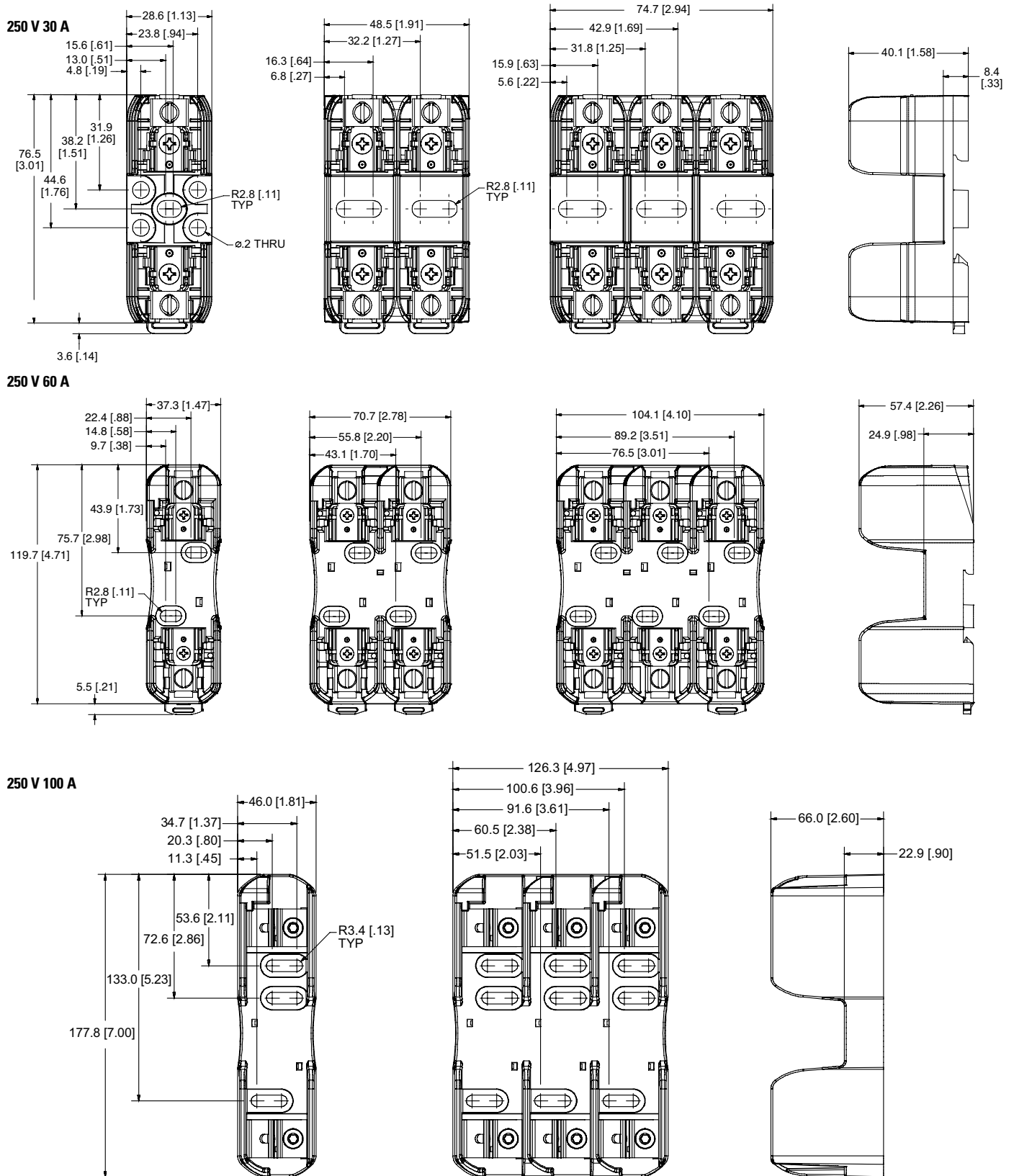

LF SERIES CLASS R & H/K5 FUSE BLOCKS

Dimensions mm (inches)

250 V 200 A

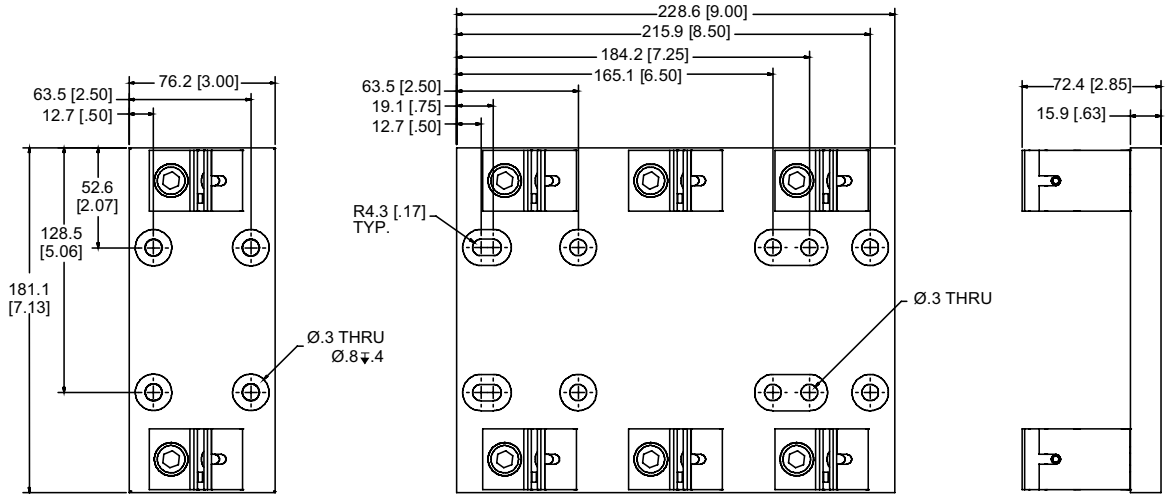

250 V 400 A

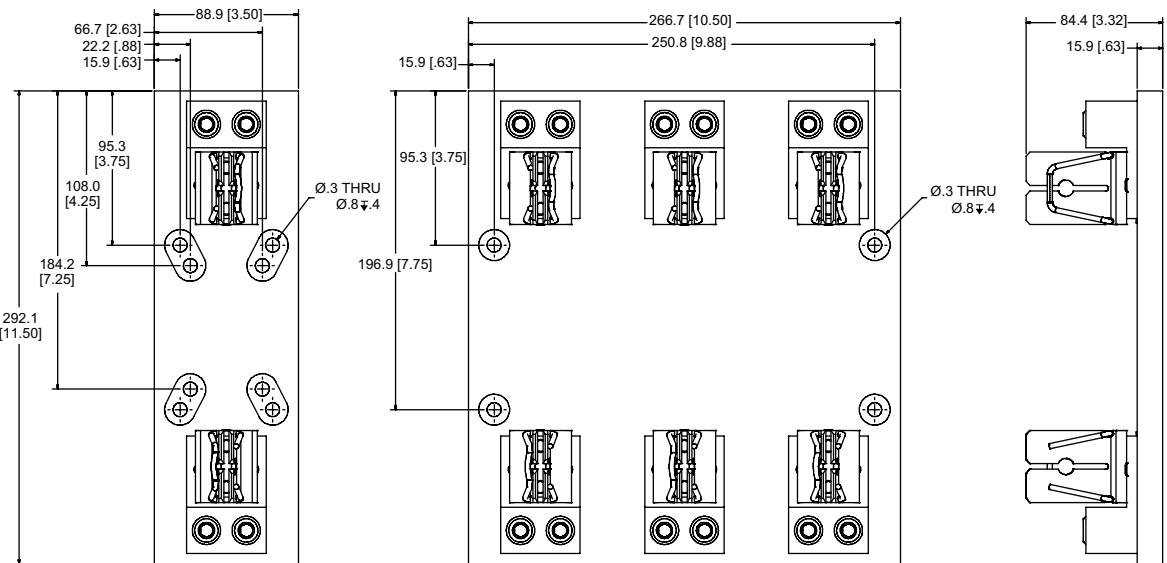

250 V 600 A

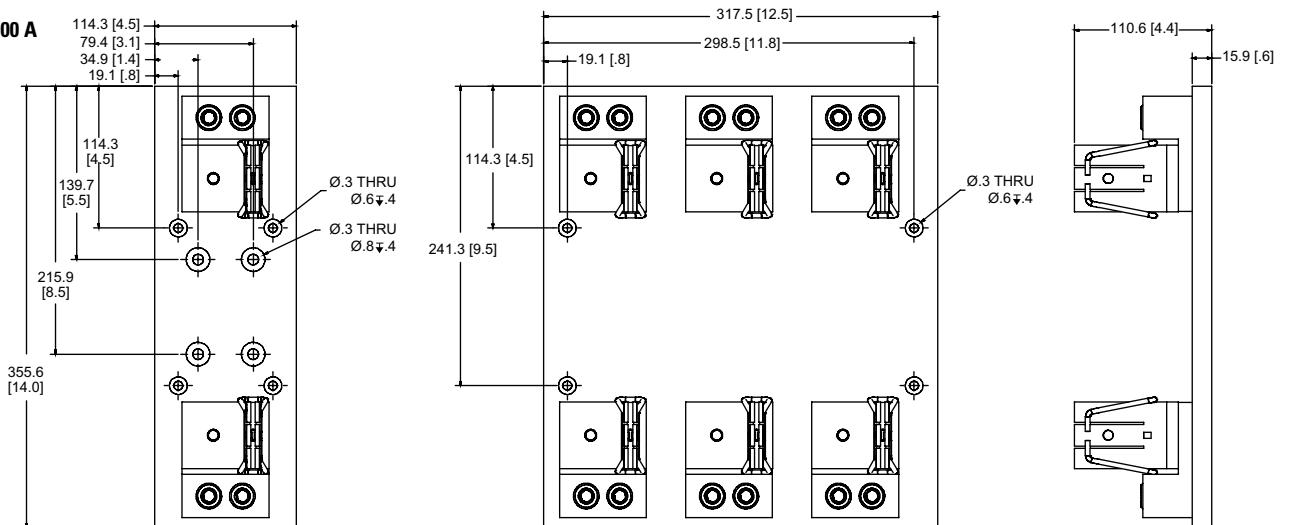

LF SERIES CLASS R & H/K5 FUSE BLOCKS

Dimensions mm (inches)

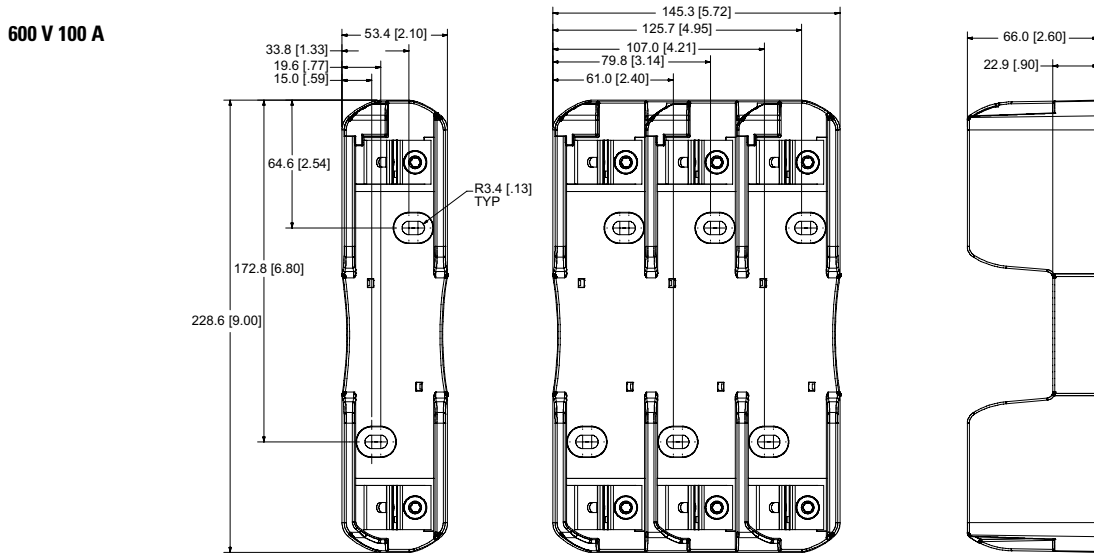
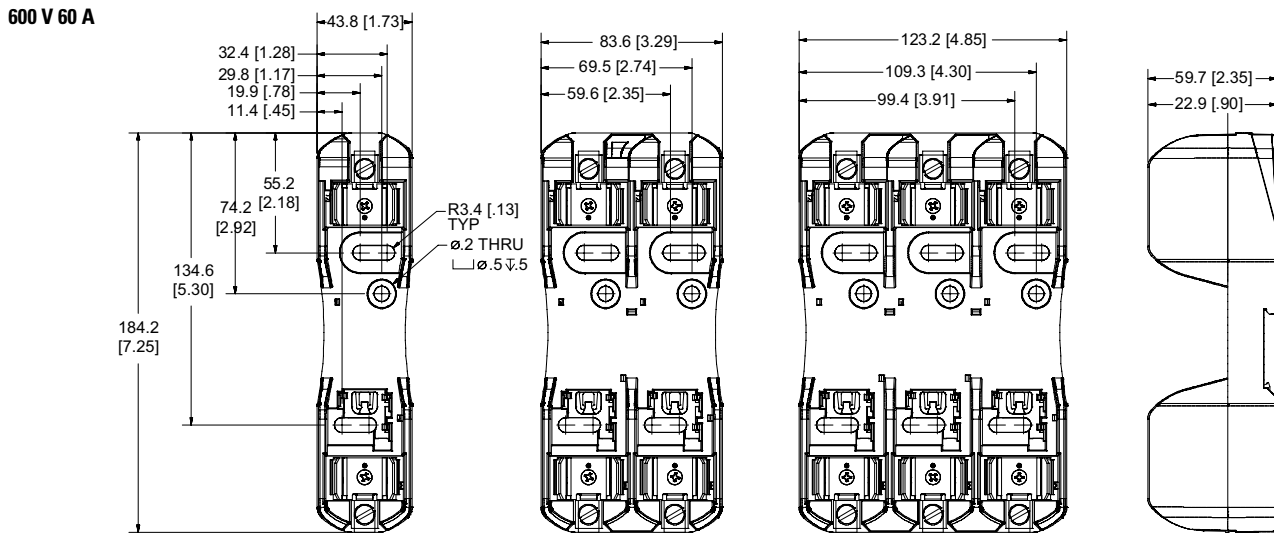
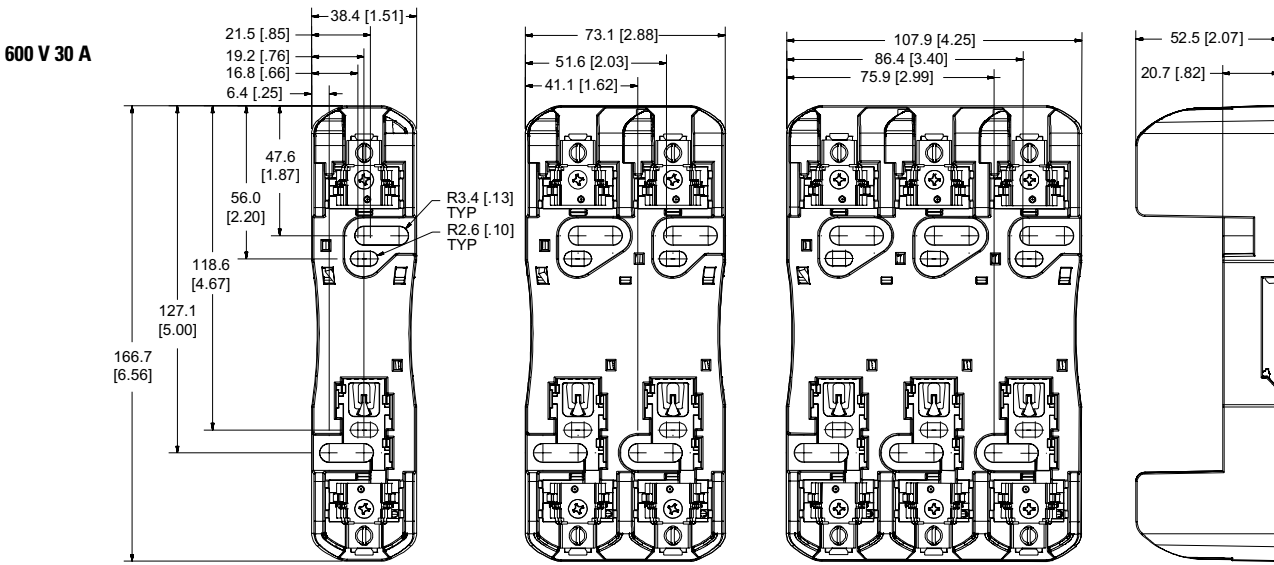

6 Fuse Blocks and Holders

LF SERIES CLASS R & H/K5 FUSE BLOCKS

Dimensions mm (inches)

600 V 200 A

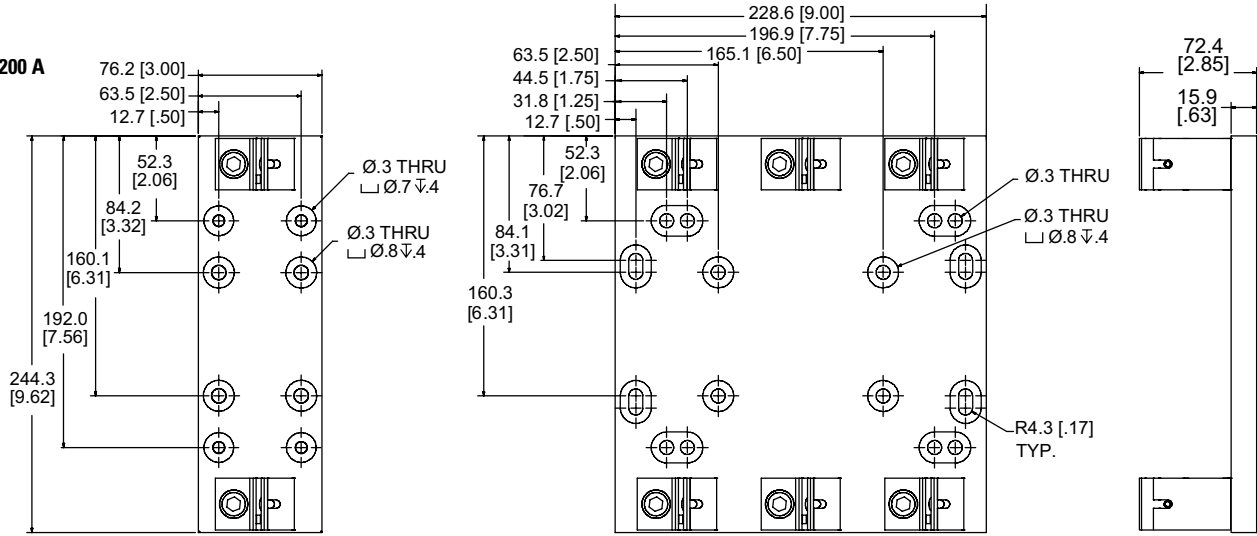

600 V 400 A

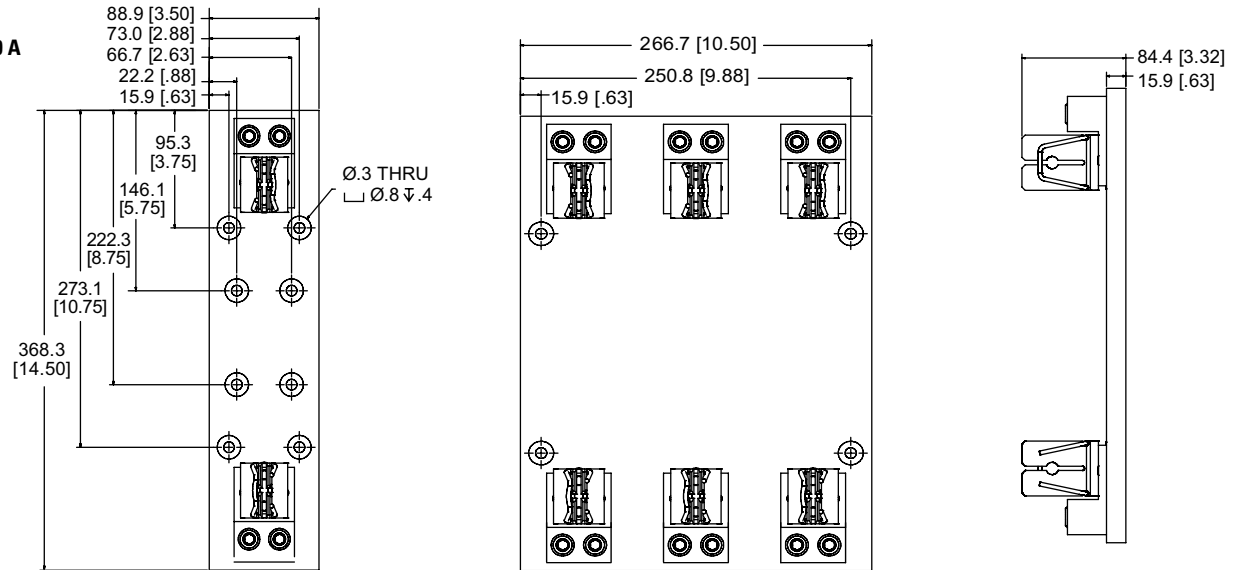

600 V 600 A

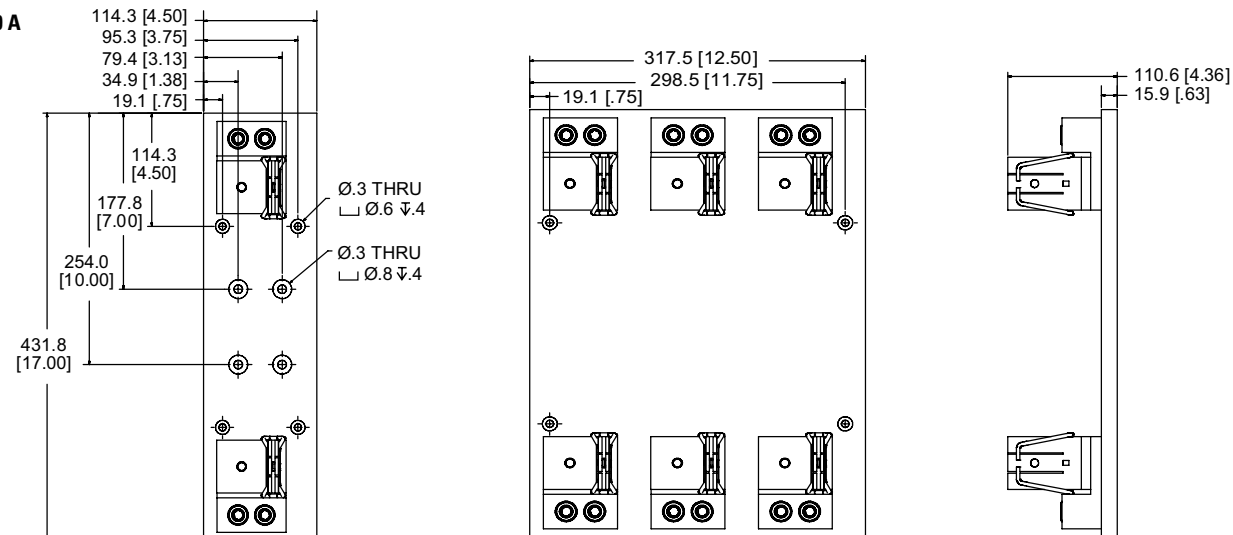

LF SERIES CLASS T FUSE BLOCKS

300 V • 600 V



Description

The Littelfuse Class T fuse blocks offer many advantages such as space saving design, universal mounting holes, snap-to-release DIN rail mounts and available covers.

Features/Benefits

- Space-saving design
- Universal mounting holes for easy replacement
- One hand release from DIN rail for 30–60 A fuses
- Reinforced fuse clips are standard
- Covers available for most amperages to enhance safety

Specifications

Voltage Ratings	300 VAC/600 VAC
Ampere Ratings	0 – 600 A
Leakage Current	<0.6 mA at 600 V
Withstand Rating	200 kA RMS SYM
Flammability Rating	UL94 V-0
Approvals	UL Listed (File: E14721) CSA Certified (File: LR7316)
Environmental	RoHS Compliant, Lead (Pb) Free

Recommended Fuses

300 V JLLN	24
600 V JLLS	24

Web Resources

Sample requests, downloadable CAD drawings and other technical information:
littelfuse.com/lft
littelfuse.com/fuseblocks

Ordering Information (Class T 300 V)

AMP RATING	ORDERING NUMBER							TORQUE	WIRE RANGE	WIRE TYPE	BASE TEMP RATING	DIN RAIL MOUNT	COVER ORDERING NUMBER*
	BASE ORDERING NUMBER	POLES			TERMINAL SUFFIX								
		1	2	3	BOX LUG	PRESSURE PLATE	SCREW						
30	LFT30030	1	2	3	C	—	—	5.6 N-m (50 in-lbs) 2.8 N-m (25 in-lbs)	2-4 AWG 6-14 AWG	CU-AL Solid/Stranded	125°C	•	LFT30030FBC
60	LFT30060	1	2	3	C	—	—	5.6 N-m (50 in-lbs) 2.8 N-m (25 in-lbs)	2-4 AWG 6-14 AWG		125°C	•	LFT30060FBC
100	LFT30100	1	—	3	CS	—	—	13.6 N-m (120 in-lbs) 4.5 N-m (40 in-lbs)	2/0-6 AWG 8 AWG	CU-AL Solid/Stranded	130°C	—	LFT30100FBC
200	LFT30200	1	—	3	CS	—	—	4.0 N-m (35 in-lbs) 31.1 N-m (275 in-lbs)	10-14 AWG 250 kcmil-6		130°C	—	—
400	LFT30400	1	—	3	CS	—	—	(2) 31.1 N-m (275 in-lbs)	250 kcmil-6		130°C	—	—
600	LFT30600	1	—	3	CS	—	—	(2) 42.4 N-m (375 in-lbs)	500 kcmil-6	130°C	—	—	

Ordering Information (Class T 600 V)

AMP RATING	ORDERING NUMBER							TORQUE	WIRE RANGE	WIRE TYPE	BASE TEMP RATING	DIN RAIL MOUNT	COVER ORDERING NUMBER*
	BASE ORDERING NUMBER	POLES			TERMINAL SUFFIX								
		1	2	3	BOX LUG	PRESSURE PLATE	SCREW						
30	LFT60030	1	2	3	C	P	S	5.6 N-m (50 in-lbs) 2.8 N-m (25 in-lbs)	2-4 AWG 6-14 AWG	CU-AL Solid/Stranded	125°C	•	LFT60030FBC
60	LFT60060	1	2	3	C	—	—	5.6 N-m (50 in-lbs) 2.8 N-m (25 in-lbs)	2-4 AWG 6-14 AWG		125°C	•	LFT60060FBC
100	LFT60100	1	—	3	CS	—	—	13.6 N-m (120 in-lbs) 4.5 N-m (40 in-lbs)	2/0-6 AWG 8 AWG	CU-AL Solid/Stranded	130°C	—	LT60100FBC
200	LFT60200	1	—	3	CS	—	—	4.0 N-m (35 in-lbs) 31.1 N-m (275 in-lbs)	10-14 AWG 250 kcmil-6		130°C	—	LT60200FBC
400	LFT60400	1	—	3	CS	—	—	(2) 31.1 N-m (275 in-lbs)	250 kcmil-6		130°C	—	LT60400FBC
600	LFT60600	1	—	3	CS	—	—	(2) 42.4 N-m (375 in-lbs)	500 kcmil-6	130°C	—	LT60600FBC	

* Covers sold individually. One cover needed for each pole.
 † Wire Type for Pressure Plate and Screw Terminal is CU only

LF SERIES CLASS T FUSE BLOCKS

Dimensions mm (inches)

300 V 30 A

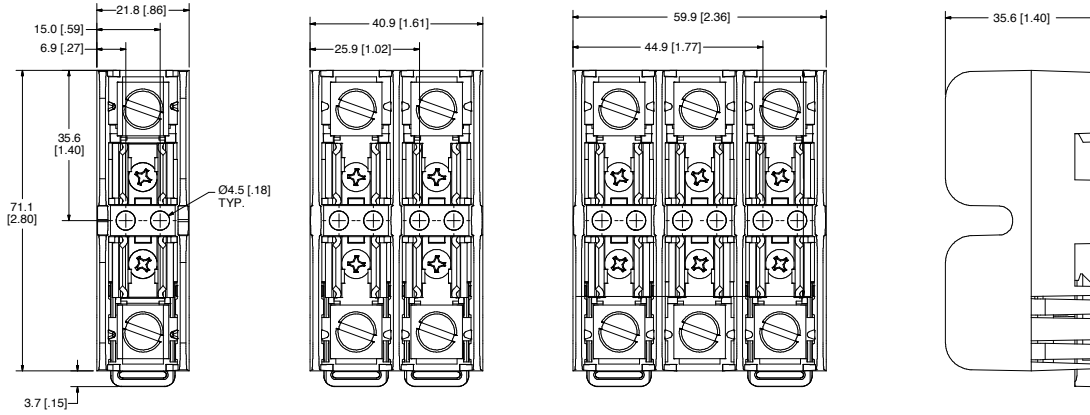

300 V 60 A

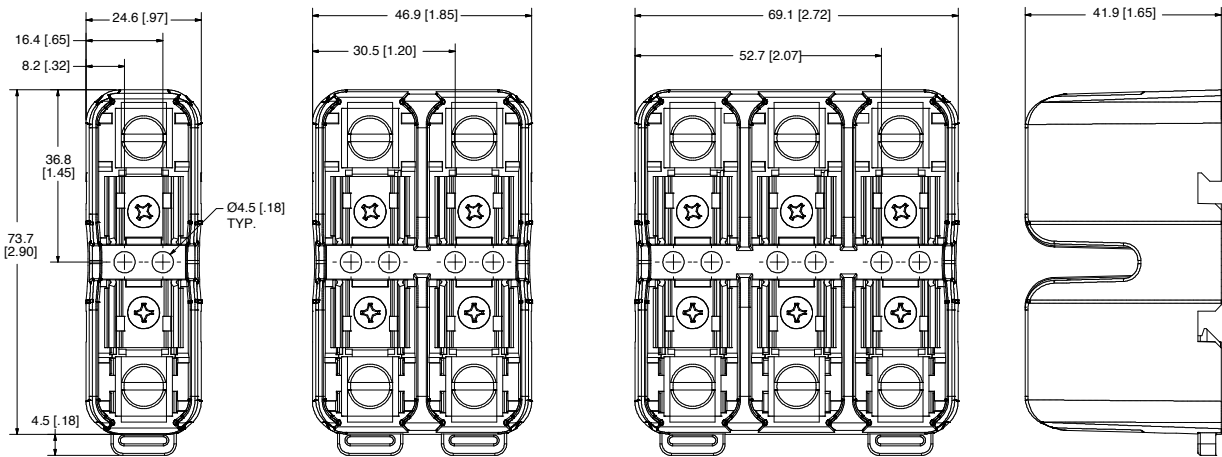

300 V 100 A

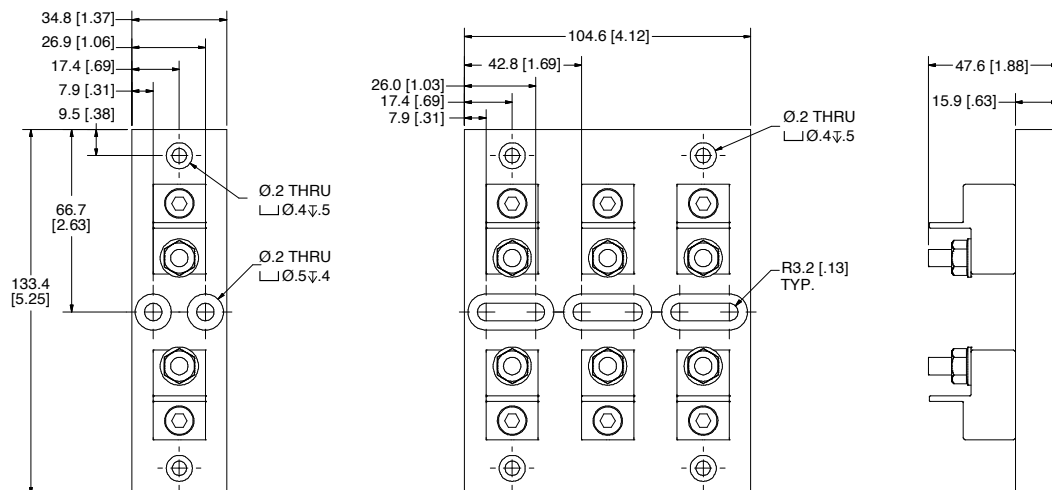

LF SERIES CLASS T FUSE BLOCKS

Dimensions mm (inches)

300 V 200 A

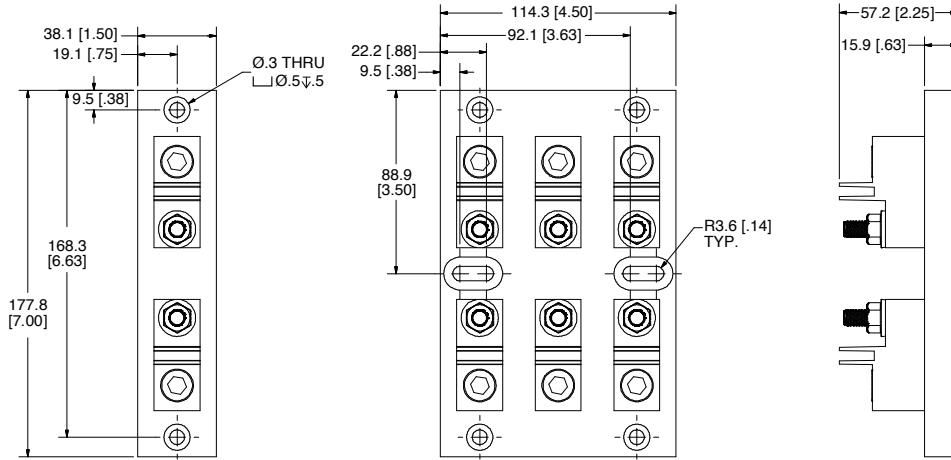

300 V 400 A

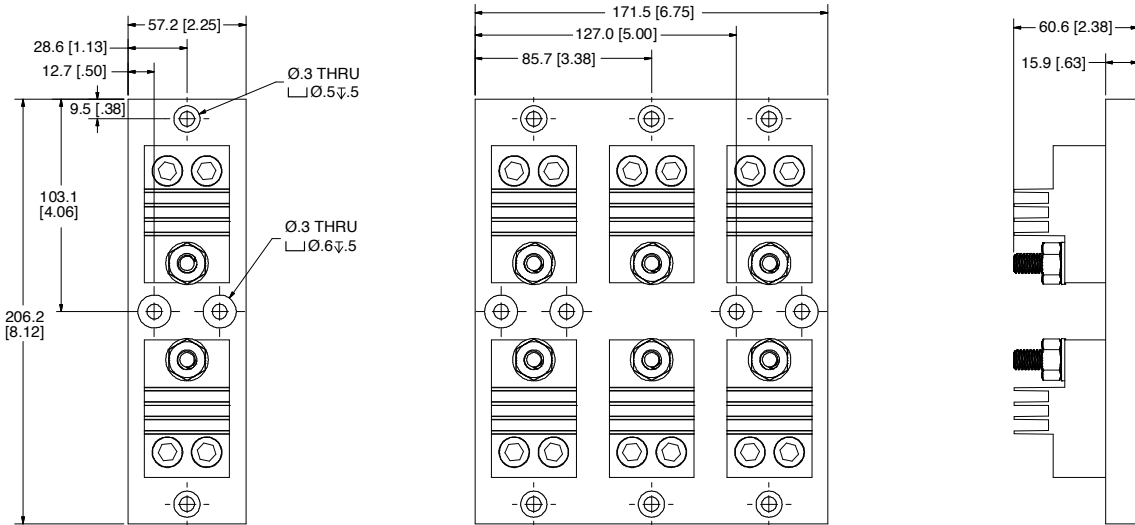

300 V 600 A

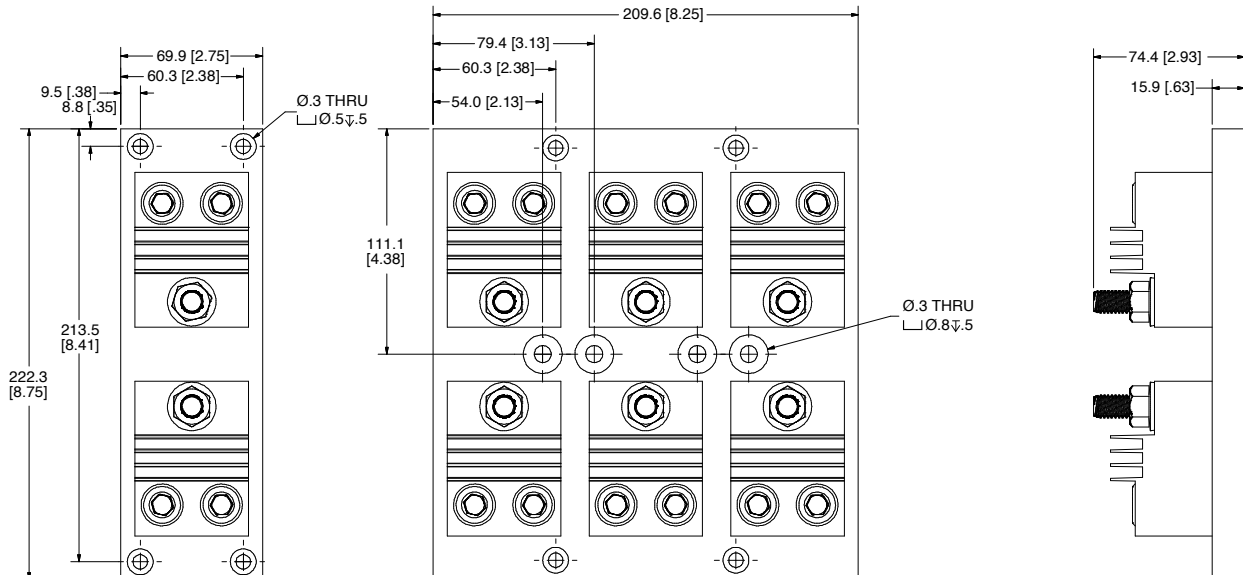

LF SERIES CLASS T FUSE BLOCKS

Dimensions mm (inches)

600 V 30 A

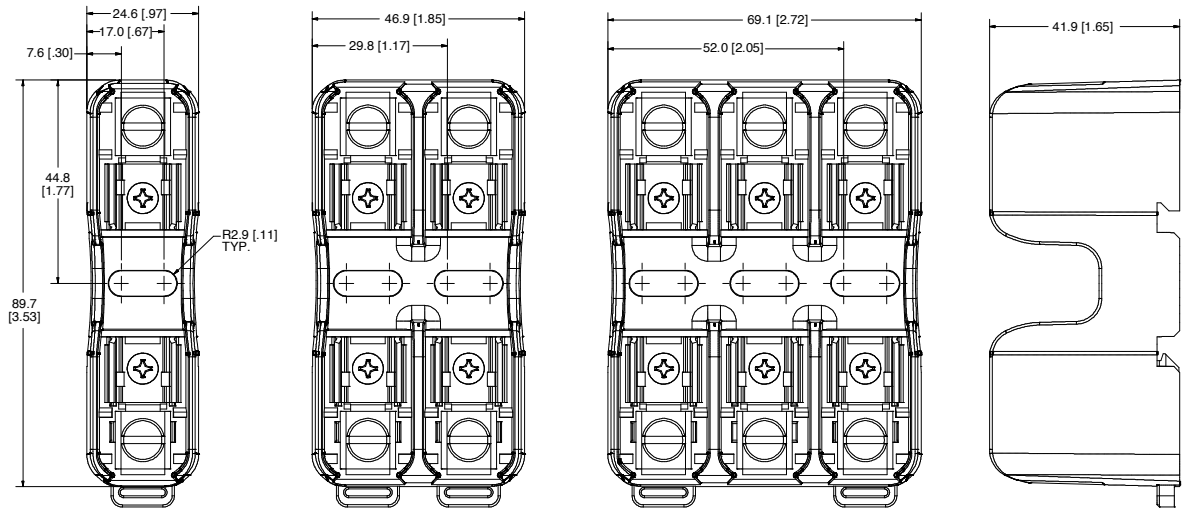

600 V 60 A

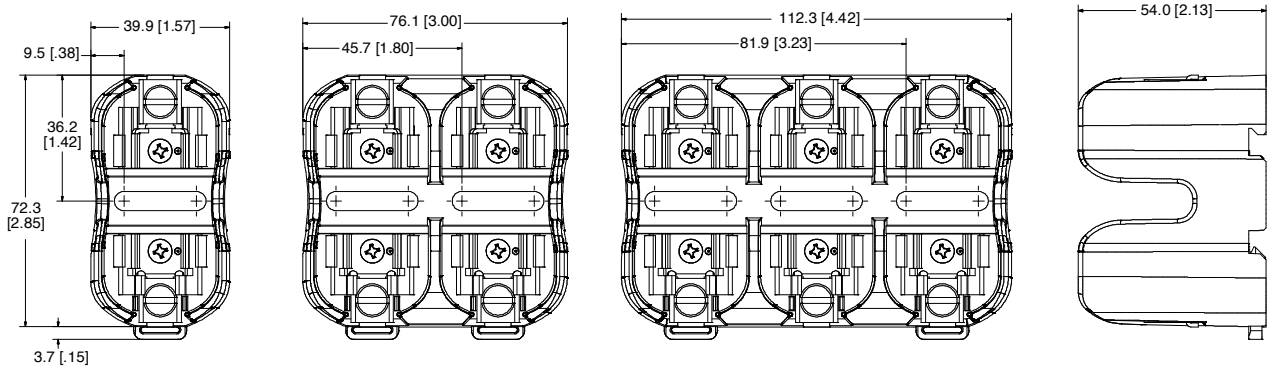

600 V 100 A

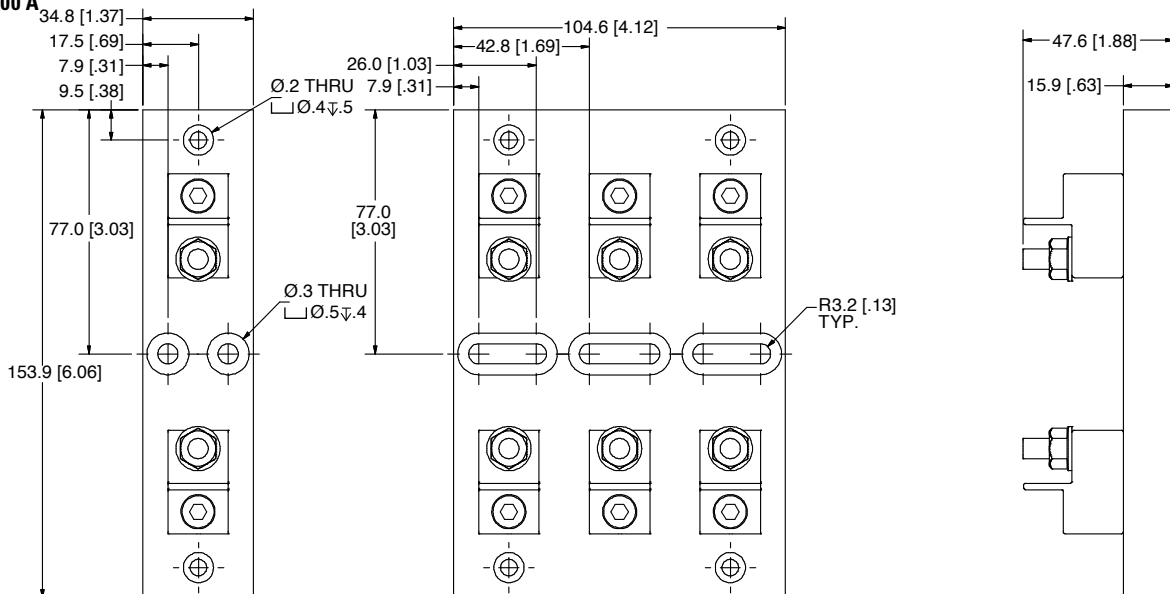

6 Fuse Blocks and Holders

LF SERIES CLASS T FUSE BLOCKS

Dimensions mm (inches)

600 V 200 A

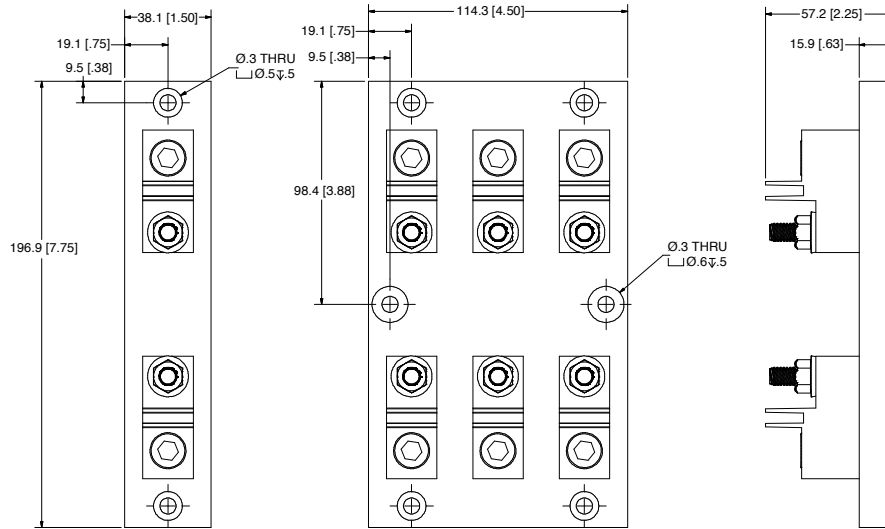

600 V 400 A

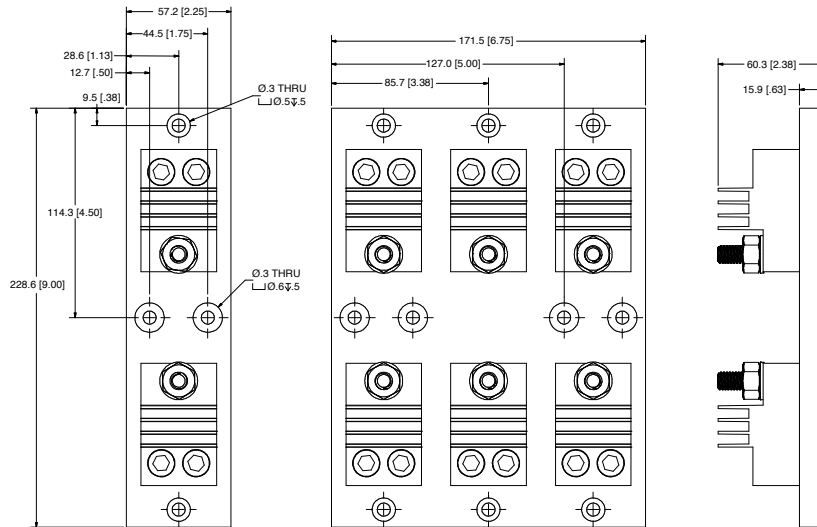

600 V 600 A

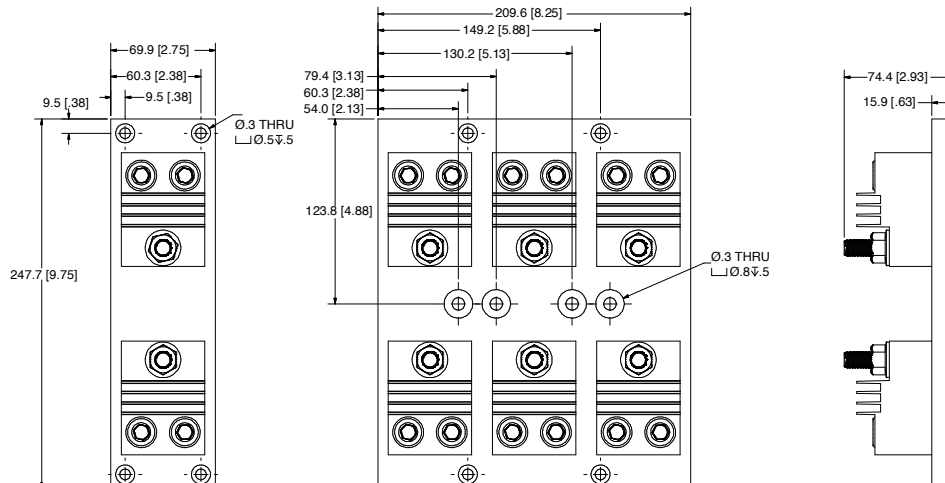

LF SERIES CLASS G FUSE BLOCKS

480 V • 600 V



Description

All Littelfuse Class G fuse blocks offer snap-to-release DIN rail mounting and universal mounting holes. Class G fuse blocks are designed for use with time-delay current limiting Class G fuses.

Features/Benefits

- Universal mounting holes for easy replacement
- One hand release from DIN rail for most amperages
- Meet requirements for branch circuit protection

Specifications

Voltage Ratings	600 Vac (0–20 A) 480 Vac (25–60 A)
Ampere Ratings	0–60 A
Flammability Rating	UL94 V-0
Approvals	UL Listed (File: E14721) CSA Certified (File: LR7091)

Recommended Fuses

Time Delay	
Series: SLC.....	26

Web Resources

Download CAD drawings and other technical information:
littelfuse.com/lfg

Ordering Information (Class G 600 V)

AMP RATING	POLES	ORDERING NUMBER			WIRE TYPE	BASE TEMP RATING	DIN RAIL MOUNT	TERMINAL INFORMATION				
		BASE PART NUMBER	BOX LUG	SUFFIX PRESSURE PLATE				SCREW	TERMINAL	WIRE RANGE	TORQUE	
15	1	LFG600151	CDINR	PODINR	SQDINR	CU Only	Solid / Stranded	150° C	•	Box Lug	6-14 AWG	4.0 N-m (35 in-lbs)
	2	LFG600152	CDINR	PODINR	SQDINR					Pressure Plate	10-14 AWG	2.3 N-m (20 in-lbs)
	3	LFG600153	CDINR	PODINR	SQDINR					Screw	10-14 AWG	2.3 N-m (20 in-lbs)
20	1	LFG600201	CDINR	PODINR	SQDINR	CU Only	Solid / Stranded	150° C	•	Box Lug	6-14 AWG	4.0 N-m (35 in-lbs)
	2	LFG600202	CDINR	PODINR	SQDINR					Pressure Plate	10-14 AWG	2.3 N-m (20 in-lbs)
	3	LFG600203	CDINR	PODINR	SQDINR					Screw	10-14 AWG	2.3 N-m (20 in-lbs)

Ordering Information (Class G 480 V)

AMP RATING	POLES	ORDERING NUMBER			WIRE TYPE	BASE TEMP RATING	DIN RAIL MOUNT	TERMINAL INFORMATION				
		BASE PART NUMBER	BOX LUG	SUFFIX PRESSURE PLATE				SCREW	TERMINAL	WIRE RANGE	TORQUE	
30	1	LFG480301	CDINR	PODINR	SQDINR	CU Only	Solid / Stranded	150° C	•	Box Lug	6-14 AWG	4.0 N-m (35 in-lbs)
	2	LFG480302	CDINR	PODINR	SQDINR					Pressure Plate	10-14 AWG	2.3 N-m (20 in-lbs)
	3	LFG480303	CDINR	PODINR	SQDINR					Screw	10-14 AWG	2.3 N-m (20 in-lbs)
60	1	LFG480601	CDINR	—	—	CU/Al	Solid / Stranded	125° C	•	Box Lug	2-4 AWG	5.6 N-m (50 in-lbs)
	2	LFG480602	CDINR	—	—						6-14 AWG	2.8 N-m (25 in-lbs)
	3	LFG480603	CDINR	—	—							

LF SERIES CLASS G FUSE BLOCKS

Dimensions mm (inches)

600 V 15 & 20 A
480 V 30 A

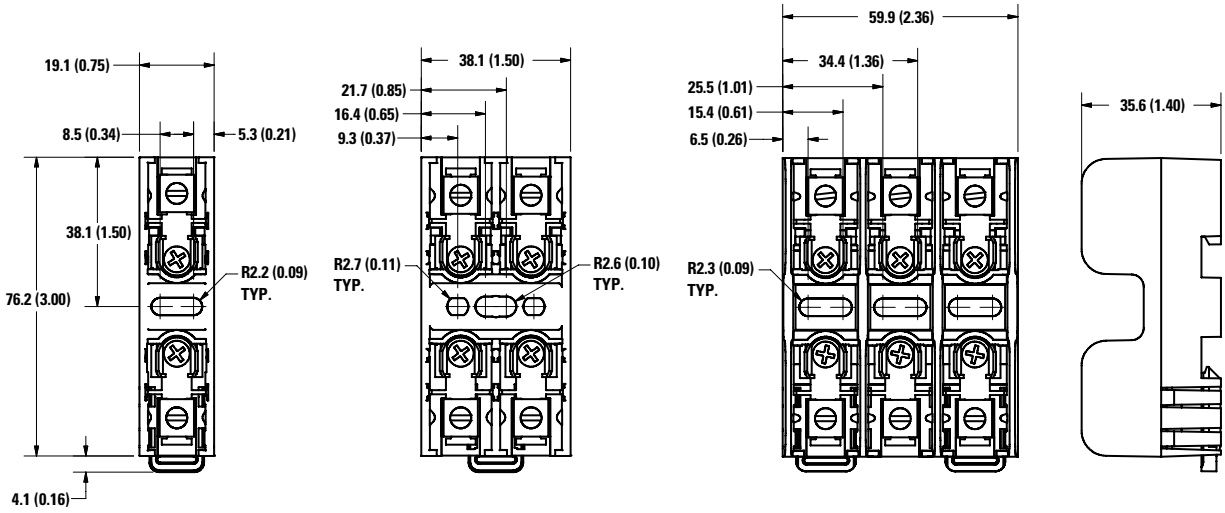

480 V 60 A

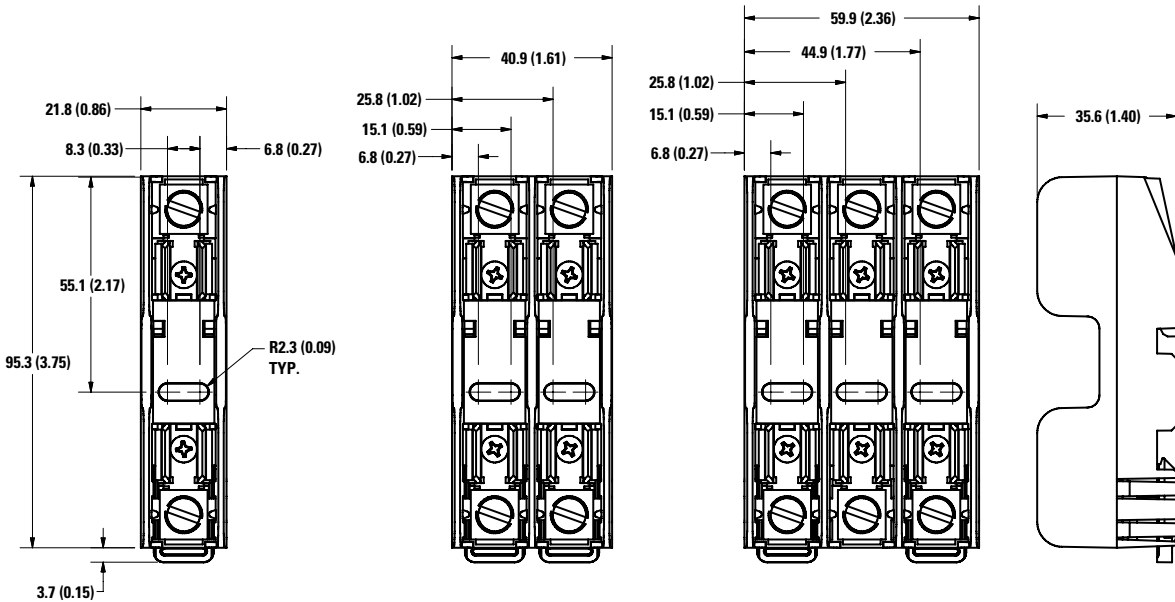

LF SERIES CLASS CC/CD AND MIDGET (10x38 mm) FUSE BLOCKS

600 V



Description

The Littelfuse Class CC, CD and midget blocks offer generous space savings and enhanced value. DIN-rail mounting and universal mounting holes are available as well as an indication feature on all Class CD fuse blocks.

Features/Benefits

- Space-saving design
- Universal mounting holes for easy replacement
- Indication offered on CD blocks
- One hand release from DIN rail optional
- Rejection feature that prevents the insertion of fuses with lower interrupting rating or voltage ratings
- Clip design reduces resistance and heat
- Non DIN-rail fuse blocks have interlocking feature allowing ganging for any number of poles
- Covers available for all amperages to enhance safety

Specifications

Voltage Rating	600 Vac/dc
Ampere Ratings	L600M Midget (10x38): 30 A L600C Class CC: 30 A LFC Class CD: 60 A L600CM Class CC & Midget: 30 A
Dielectric strength	1200 V minimum
Materials	Clip/terminals: Tin-plated copper alloy Box lug: Copper Screw & captive pressure plate: Zinc-plated steel Base: Thermoplastic UL94 V-0 flammability rating
Withstand Rating (SCCR)	L60030C: 200kA L60030M: 10kA, 20kA or 100kA based on the Midget fuse used LFC600: 200kA
Approvals	L600M: UL Recognized (File: E14721) CSA Certified (File: LR7316) L600C: UL Listed (File: E14721) CSA Certified (File: LR7316) LFC: UL Listed (File: E14721) CSA Certified (File: LR7316) L600CM: UL Recognized (File: E14721) CSA Certified (File: LR7316)
Environmental	RoHS Compliant, Lead (Pb) Free

Recommended Fuses

Class CC Blocks:	CCMR, KLDR, KLKR
Class CM Block:	Fuses same as CC & Midget Blocks
Class CD Blocks:	CCMR
Midget Blocks:	BLF, BLN, BLS, FLA, FLM, FLO, FLU, KLK, KLKD, KLO

Web Resources

Sample requests and technical downloads:
littelfuse.com/fuseblocks

Ordering Information (L600C Class CC and L600M Midget 30 A)

AMP RATING	POLES	CLASS CC ORDERING NUMBER		MIDGET ORDERING NUMBER		CONNECTOR TYPE	TORQUE	WIRE RANGE	WIRE TYPE	BASE TEMP	COVER ORDERING NUMBER†	
		NON-DIN*	DINR	NON-DIN*	DINR							
30	1	L60030C1C	L60030C1CDINR	L60030M1C	L60030M1CDINR	Box Lug	4.0 N-m (35 in-lbs)	6-14 AWG	CU Only Solid / Stranded	125°C	SPL001	
	2	L60030C2C	L60030C2CDINR	L60030M2C	L60030M2CDINR							
	3	L60030C3C	L60030C3CDINR	L60030M3C	L60030M3CDINR							
30	1	L60030C1PQ	L60030C1PQDINR	L60030M1PQ	L60030M1PQDINR	Pressure Plate w/Q.C. Terminal	2.3 N-m (20 in-lbs)	10-14 AWG		CU Only Solid / Stranded	125°C	SPL001
	2	L60030C2PQ	L60030C2PQDINR	L60030M2PQ	L60030M2PQDINR							
	3	L60030C3PQ	L60030C3PQDINR	L60030M3PQ	L60030M3PQDINR							
30	1	L60030C1SQ	L60030C1SQDINR	L60030M1SQ	L60030M1SQDINR	Screw w/Q.C. Terminal	2.3 N-m (20 in-lbs)	10-14 AWG	CU Only Solid / Stranded	125°C	SPL001	
	2	L60030C2SQ	L60030C2SQDINR	L60030M2SQ	L60030M2SQDINR							
	3	L60030C3SQ	L60030C3SQDINR	L60030M3SQ	L60030M3SQDINR							

Ordering Information (L600CM Class CC and Midget Combination 30 A)

AMP RATING	POLES		COMBINATION 2 CLASS CC / 1 MIDGET ORDERING NUMBER		CONNECTOR TYPE	TORQUE	WIRE RANGE	WIRE TYPE	BASE TEMP	COVER ORDERING NUMBER†
	CLASS CC	MIDGET	NON-DIN	DINR						
30	2	1	L60030CM3PQ	—	Pressure Plate w/Q.C. Terminal	2.3 N-m (20 in-lbs)	10-14 AWG	CU Only Solid / Stranded	125°C	SPL001

LF SERIES CLASS CC/CD AND MIDGET (10X38 mm) FUSE BLOCKS

Ordering Information (LFC Class CD 60 A)

AMP RATING	POLES	ORDERING NUMBER	CONNECTOR TYPE	TORQUE	WIRE RANGE	WIRE TYPE		BASE TEMP RATING	DIN RAIL MOUNT	INDICATION	COVER ORDERING NUMBER*
60	1	LFC600601CID	Box Lug	5.6 N-m (50 in-lbs)	2-4 AWG	CU-AL	Solid / Stranded	125°C	•	•	LFC60060FBC
	2	LFC600602CID		2.8 N-m (25 in-lbs)	6-14 AWG						
	3	LFC600603CID									

* Gangable – † Covers sold individually. One cover needed for each pole.

Dimensions mm (inches)

L600M-DINR Midget and L600C-DINR Class CC 30 A

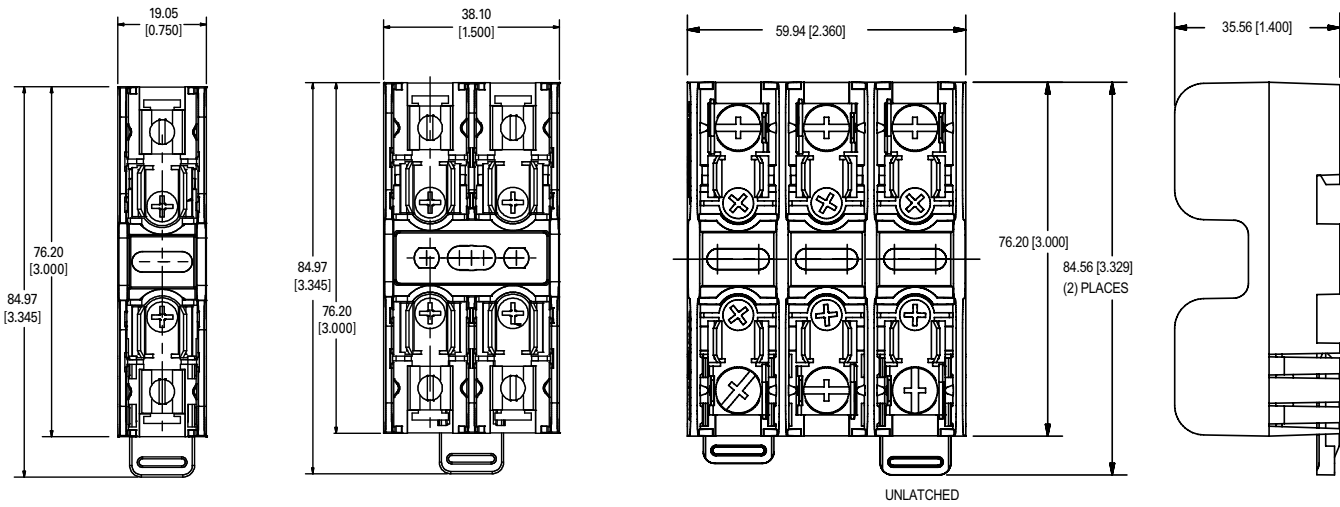

L600M Midget, L600C Class CC and L600CM Combination 30 A

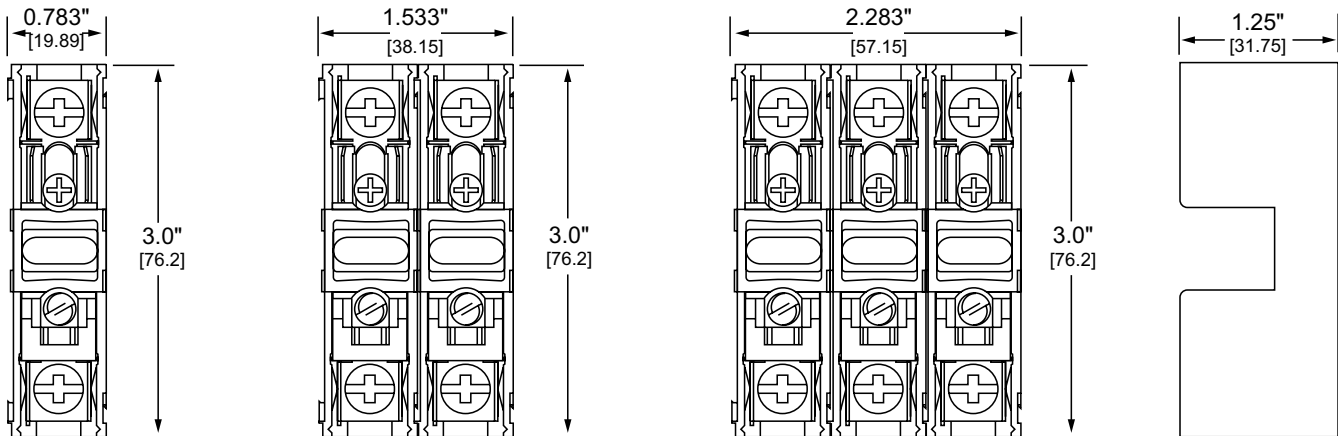

LF SERIES CLASS CC/CD AND MIDGET (10X38 mm) FUSE BLOCKS

Dimensions mm (inches)

LFC CLASS CD 60 A

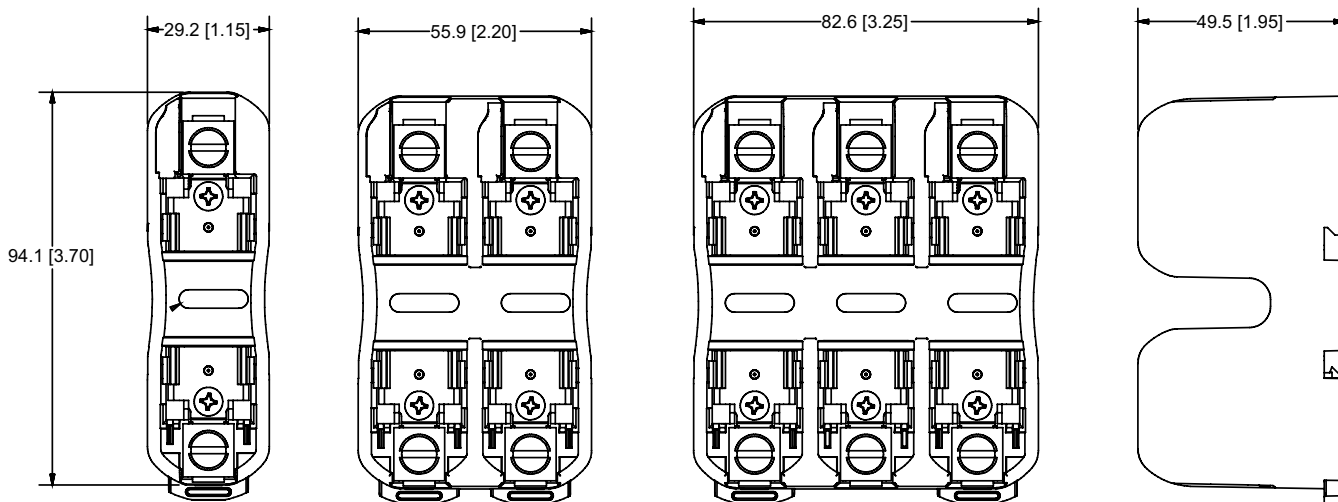

BOARD MOUNT MIDGET (10X38 mm) FUSE HOLDER

600 V



Specifications

Voltage Rating	600 Vac/dc
Amperage Rating	30 A
Approval	UL Recognized (File: E14721)
Mounting Method	Through hole solder/PCB

Ordering Information

	CATALOG NUMBER	ORDERING NUMBER
Block	L60030M3PCB	L60030M3PCB
Cover*	SPL001PCB	SPL0001PCBT

*Covers are single pole—need to order a quantity of 3 for each block.

Recommended Fuses

Midget (10 x 38 mm) series 30

Web Resources

Download CAD drawings and other technical information:
littelfuse.com/fuseblocks

Dimensions mm (inches)

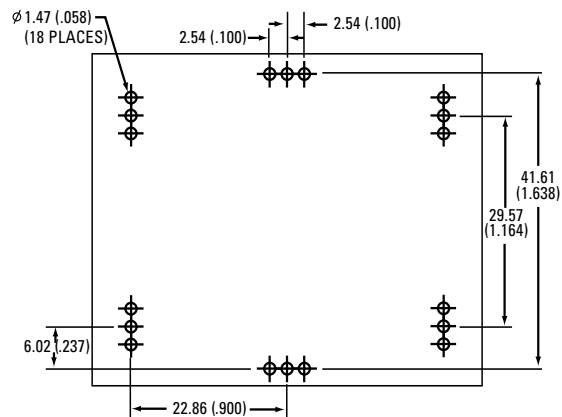
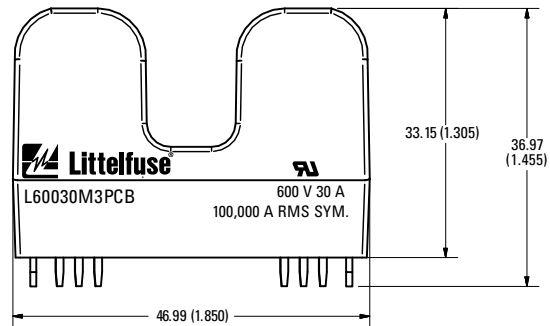

Description

The PC board-mounted midget fuse holder is a one-piece holder designed to provide a more robust and secure solution. It offers a smaller footprint and flexible mounting options.

For use with Midget-style fuses and fuse covers, it is UL Recognized and can be covered for additional protection.

Features/Benefits

- Through hole PCB mounting
- Robust and secure block design
- All-in-one package offers easy installation
- Space saving footprint
- Touch Safe cover/puller available
- 3-pole configurations

Applications

- HVAC market
- Industrial manufacturing
- Mass production facilities

SPL001PCB Cover

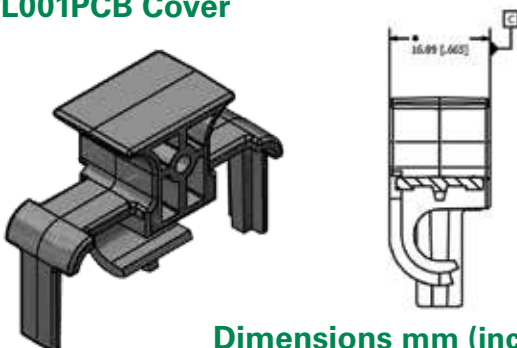

Dimensions mm (inches)

CLASS CC AND MIDGET FUSE BLOCK ACCESSORIES

FBDIN1 Rail Adapter

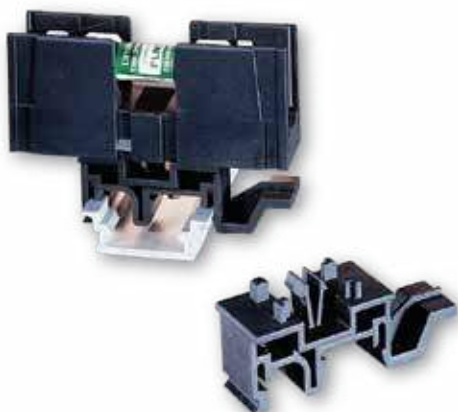

Features/Benefits

- DIN Rail adaptor for 30 A Midget, Class CC and Class G fuse blocks
- Patented design with no tools necessary for installation
- Permits snap-mounting of 30 A Midget, Class CC and Class G fuse blocks to standard and low profile 35 mm symmetrical DIN rails and 32 mm asymmetrical DIN rails
- Easy removal via disconnect tab

Web Resources

For additional technical information visit:
littelfuse.com/fbdin1

Dimensions Inches

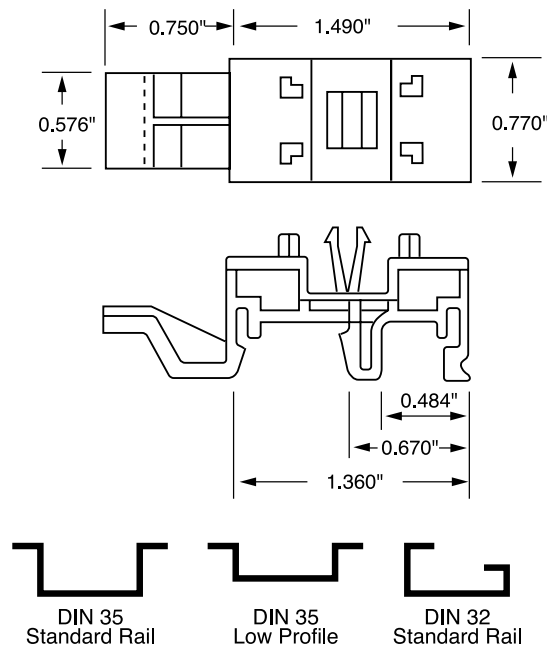

Recommended Fuse Blocks

Midget-Style and Class CC	107
Class G	105

New DIN rail mountable fuse holders available on page 107

SPL001 Cover Puller



Features/Benefits

- 600 V 1/10-30 A Class CC and Midget fuse cover puller that offers increased protection when removing fuses
- Simple removal without the need for a separate puller
- Meets Dead Front requirements
- Easily gangable with 1/8" diameter wire
- For use with all 600 V Class CC and Midget 1/10-30 A fuses
- Label provided for easy fuse identification

Dimensions Inches

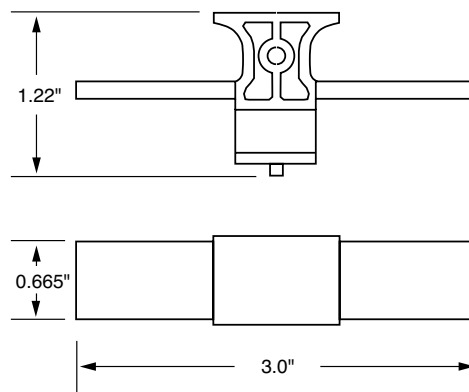

Recommended Fuse Blocks

L60030C	107
L60030M	107

Web Resources

For additional technical information visit:
littelfuse.com/spl001

LF SERIES FUSE BLOCK COVERS



Description

Littelfuse fuse block covers protect personnel from accidentally coming into contact with energized parts. Covers are for use with Littelfuse LF Series UL class fuse blocks.

Contact the Littelfuse Tech-Line (800-TEC-FUSE) for block and cover compatibility questions.

Specifications

Connection	Snap to fuse body
Material	Black thermoplastic
Flammability Rating	UL94 V-0
Approvals	UL Listed (File: E184929) CSA Certified (File: 007316_0_000 Class 6225-01)

Features/Benefits

- Added safety to personnel
- Ventilation helps avoid fuse derating
- Reusable and convenient snap-on design
- UL listed and CSA certified
- Available for Class H/R, Class J, Class T and Class CD
- Allows visibility of LF series fuse block indicator

Web Resources

For dimensions, cad drawings and additional technical information visit: littelfuse.com/fuseblocks

Ordering Information

UL CLASS	FUSE BLOCK BASE PART NUMBER*	VOLTAGE	AMPERAGE	COVER ORDERING NUMBER
Class H/R	LFH25030 / LFR25030	250	30	LFH25030FBC
Class H/R	LFH25060 / LFR25030	250	60	LFH25060FBC
Class H/R	LFH25100 / LFR25100	250	100	LFH25100FBC
Class H/R	LFH60030 / LFR60030	600	30	LFH60030FBC
Class H/R	LFH60060 / LFR60060	600	60	LFH60060FBC
Class H/R	LFH60100 / LFR60100	600	100	LFH60100FBC
Class J	LFJ60030	600	30	LFJ60030FBC
Class J	LFJ60060	600	60	LFJ60060FBC
Class J	LFJ60100	600	100	LFJ60100FBC†
Class T	LFT30030	300	30	LFT30030FBC
Class T	LFT30060	300	60	LFT30060FBC
Class T	LFT30100	300	100	LFT30100FBC
Class T	LFT60030	600	30	LFT60030FBC
Class T	LFT60060	600	60	LFT60060FBC
Class T	LFT60100	600	100	LT60100FBC
Class T	LFT60200	600	200	LT60200FBC
Class T	LFT60400	600	400	LT60400FBC
Class T	LFT60600	600	600	LT60600FBC
Class CD	LFC60060	600	60	LFC60060FBC
Class CC	L60030C	600	30	SPL001

* Part number shown excludes reference to number of poles and terminal type
† Cover is not compatible with 70-100 A JLS series fuses

LPXV TOUCH-SAFE FUSE HOLDERS

1500 V • 30 A



Specifications

Voltage Ratings	1500 Vdc
Amperage Rating	30 A
SCCR Rating	15 kA
Fuse Type	10x85mm
Material	Thermoplastic
Operating Temperature	-40°C to +125°C
Flammability Rating	UL94 V-0
Temperature Stability	Body: 125° C Carrier: 140° C
Approvals	UL 4248-18 Listed (File: E345481) IEC 60269-1 & IEC 60269-2
Environmental	RoHS compliant, Lead (Pb) free



Description

The Littelfuse LPXV fuse holder is designed to hold 1500 V 10x85mm fuses.

Features/Benefits

- Finger-Safe design offers personnel protection
- No fuse pullers or tools required for fuse removal
- 35 mm DIN Rail Mountable
- Compact design

Recommended Fuses

Littelfuse SPXV 1500 V Fuses.....58

Web Resources

Download the complete datasheet and other technical documents: Littelfuse.com/lpxv

Dimensions Inches (mm)

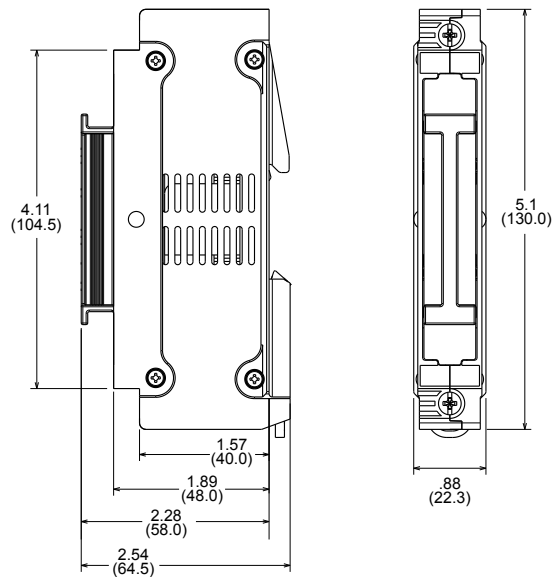

Ordering Information

SERIES	VOLTAGE (Vdc)	POLES	CATALOG NUMBER	ORDERING NUMBER	PACK QTY	TERMINAL INFORMATION				
						TERMINAL TYPE	WIRE TYPE	NUMBER OF WIRES	WIRE SIZE	TORQUE
LPXV	1500	1	LPXV001	LPXV0001Z	5	Box Lug	90° Max CU Only Stranded	1	6-4 AWG (16-25 mm ²)	22-26 lb-in (2.5-3 N-m)
								1	18-8 AWG (.75-10 mm ²)	18-22 lb-in (2-2.5 N-m)
								2*	18-6 AWG (.75-16 mm ²)	18-22 lb-in (2-2.5 N-m)

*Must be the same cross-sectioned size



Look for this logo to indicate products that are used in solar applications. Visit our website littelfuse.com/solar for the latest updates on approvals, certifications, and new products.

LFPXV TOUCH-SAFE FUSE HOLDERS

1500 V • 30 A



Specifications

Voltage Ratings	1500 Vdc
Amperage Rating	30 A
SCCR Rating	50 kA
Fuse Type	10x85mm
Material	Thermoplastic
	Fuse Clip: Silver plated copper alloy
	Screws: Zinc plated steel
Operating Temperature	-55°C to +125°C
Flammability Rating	UL94 V-0
Temperature Stability	Carrier: 130°C
Approvals	UL 4248-19 Listed (Pending) IEC 60269-6
Environmental	RoHS compliant, Lead (Pb) free

Web Resources

Download the complete datasheet and other technical documents: Littelfuse.com/lfpvx

Description

The Littelfuse LFPXV fuse holder is designed to hold 1500 V 10x85mm fuses.

Features/Benefits

- Finger-Safe design offers personnel protection
- No fuse pullers or tools required for fuse removal
- 35 mm DIN Rail Mountable
- Evaluated for use with copper alloy busbars
- Compact design

Recommended Fuses

Littelfuse SPXV 1500 V Fuses.....58

WIRE TYPE	
75°C or 90°C CU Only Stranded	UL Class B and Class C wire
	AlphaWire PV series Photovoltaic Wire
	IEC Class 5 Flexible Wire

BUSBAR SPECIFICATIONS			
TERMINAL	THICKNESS	WIDTH	TORQUE
Maximum	0.188 in (4.78 mm)	0.290 in (7.37 mm)	24-28 lb-in (2.71-3.16 N-m)
Minimum	0.125 in (3.18 mm)	0.200 in (5.08 mm)	

Ordering Information

SERIES	VOLTAGE (Vdc)	POLES	CATALOG NUMBER	ORDERING NUMBER	PACK QTY	TERMINAL TYPE	TERMINAL INFORMATION		
							NUMBER OF WIRES	WIRE SIZE	TORQUE
LFPXV	1500	1	LFPXV001	LFPXV0001Z	20	Box Lug	1	4-14 AWG (25-2.5 mm ²)	24-28 lb-in (2.71-3.16 N-m)
							1	16-18 AWG (1.5-0.75 mm ²)	18-22 lb-in (2.03-2.49 N-m)
							2*	6-14 AWG (16-2.5 mm ²)	26-30 lb-in (2.94-3.69 N-m)
							2*	16-18 AWG (1.5-0.75 mm ²)	20-24 lb-in (2.26-2.71 N-m)

*Must be the same cross-sectioned size



Look for this logo to indicate products that are used in solar applications. Visit our website littelfuse.com/solar for the latest updates on approvals, certifications, and new products.

LFJ1000 SERIES SOLAR FUSE BLOCKS

1000 Vdc • Clip-to-Box • Stud-to-Stud • Clip-to-Stud



Description

The LFJ1000 series fuse block is specifically designed for the Littelfuse SPFJ 1000 V Solar Fuse. It meets UL electrical requirements, is available in multiple amperages, and comes in a variety of fuse mounting and termination configurations; fuse clip to box lug, fuse stud to wire stud and fuse clip to wire stud.

Features/Benefits

- Narrow width increases space savings
- Range of amperages to match all SPFJ fuse options
- Box Lug termination style accommodates a wide range of cable sizes
- Stud-mounted option increases convenience
- Approval for use with copper or aluminum lugs allowing for design flexibility

Ordering Information

(Clip-to-Box Lug 1000 V)

AMPERAGE	ORDERING NUMBER	INTERRUPT RATING	WIRE RANGE STANDARD (METRIC)	WIRE TYPE	RECOMMENDED TORQUE
200	LFJ102001C	20 kA	250 kcmil - #6 (127mm ² - 16mm ²)	Cu/Al Solid/ Stranded	275 in-lb (31.1 N-m)
400	LFJ104001C	10 kA	350 kcmil - 1/0 (177mm ² - 55mm ²)		275 in-lb (31.1 N-m)
450	LFJ104501C	20 kA	500 kcmil - #4 (253mm ² - 25mm ²)		375 in-lb (42.4 N-m)

(Stud-to-Stud 1000 V)

AMPERAGE	ORDERING NUMBER	INTERRUPT RATING	RECOMMENDED TORQUE		MAX. BUSBAR THICKNESS	RECOMMENDED BASE TORQUE	
			FUSE	TERMINAL		BOLT SIZE	TORQUE
200	LFJ102001STST	20 kA	65 in-lb (7.3 N-m)	200 in-lb (22.6 N-m)	.774" (19.66 mm)	1/4" 5/16"	30-40 in-lb 40-50 in-lb
400	LFJ104001STST	10 kA	170 in-lb (19.2 N-m)	200 in-lb (22.6 N-m)	.555" (14.10 mm)		
450	LFJ104501STST	20 kA	300 in-lb (33.9 N-m)	300 in-lb (33.9 N-m)	.570" (14.18 mm)		

(Clip-to-Stud 1000 V)

AMPERAGE	ORDERING NUMBER	INTERRUPT RATING	RECOMMENDED TORQUE	MAX. BUSBAR THICKNESS	RECOMMENDED BASE TORQUE	
			TERMINAL		BOLT SIZE	TORQUE
200	LFJ102001CST	20 kA	200 in-lb (22.6 N-m)	.774" (19.66 mm)	1/4" 5/16"	30-40 in-lb 40-50 in-lb
400	LFJ104001CST	10 kA	200 in-lb (22.6 N-m)	.555" (14.10 mm)		
450	LFJ104501CST	20 kA	300 in-lb (33.9 N-m)	.570" (14.18 mm)		

Specifications

Voltage Ratings	1000 Vdc
Ampere Ratings	200, 400, 450 A
Flammability Rating	UL94 V-0
Termination Type	Box Lug or Stud Mount
Base Temp Rating	130° C
Approvals	UL 4248-18 Listed File: E345481 Vol. 1
Environmental	RoHS Compliant

Recommended Fuses

SPFJ Solar Series 63

Web Resources

Download CAD drawings, dimensions and other technical information: littelfuse.com/LFJ1000

LF SERIES SOLAR FUSE BLOCKS

1000 Vdc

Dimensions mm (inches)

Clip-to-Box

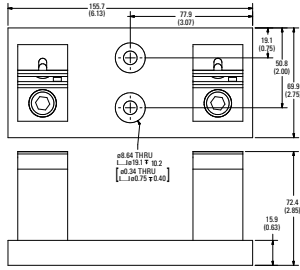

200 A

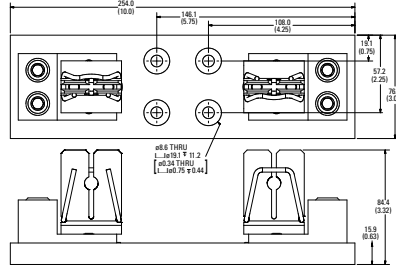

400 A

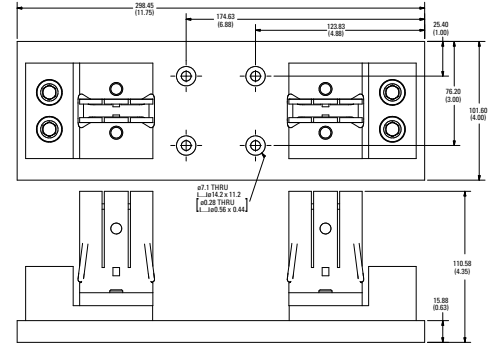

450 A

Stud-to-Stud

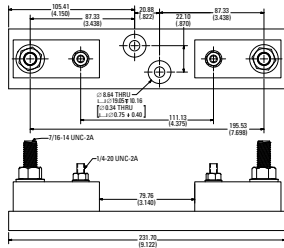

200 A

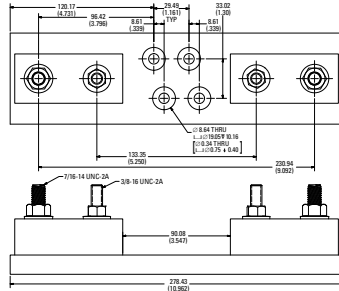

400 A

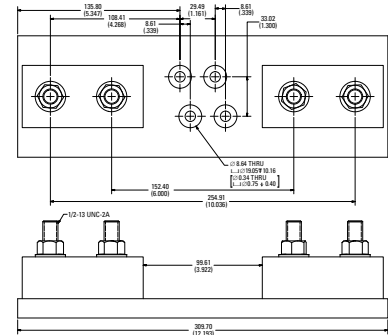

450 A

Clip-to-Stud

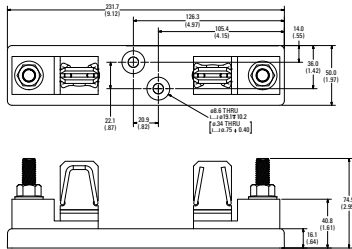

200 A

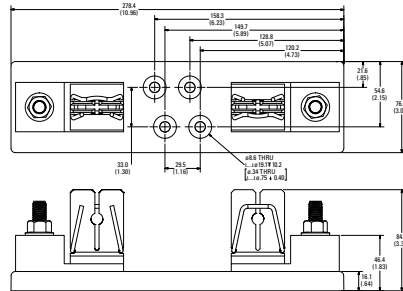

400 A

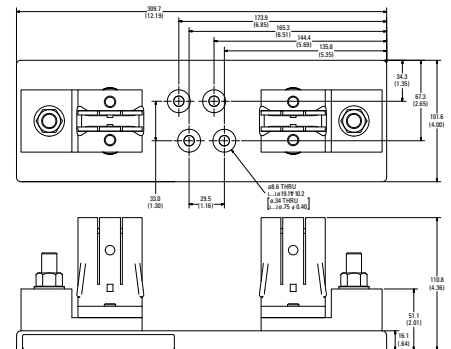

450 A



Look for this logo to indicate products that are used in solar applications. Visit our website littelfuse.com/solar for the latest updates on approvals, certifications, and new products.

LPHV POWR-SAFE FUSE HOLDERS

1000 VDC



Description

The Littelfuse LPHV fuse holder is designed to house 1000 V fuses. It is not designed for load break but is ideal for isolating photovoltaic module strings for maintenance and meets UL requirements for 1000 V solar fuse protection

Features/Benefits

- Touch-safe design offers protection when replacing fuses
- Compact design
- 35 mm DIN Rail Mountable
- Available in 1-, 2-, 3- and 4-pole configurations
- No fuse pullers or tools required for fuse removal

Multi-Pole Assembly Kit

Kits are used to create multi-pole holders from 1-pole LPHV fuse holders. Please contact factory for more information

Ordering Information

SERIES	POLES	CATALOG NUMBER	ORDERING NUMBER	TERMINAL TYPE	WIRE TYPE	WIRE RANGE	TERMINAL TORQUE	ROHS
LPHV	1	LPHV001	LPHV0001Z	Pressure Plate	75° C or 90° C CU Only	Stranded / [Solid]	17.7 in-lbs (2 N-m)	•
LPHV	2	LPHV002	LPHV0002Z					•
LPHV	3	LPHV003	LPHV0003Z					•
LPHV	4	LPHV004	LPHV0004Z					•

Dimensions Inches (mm)

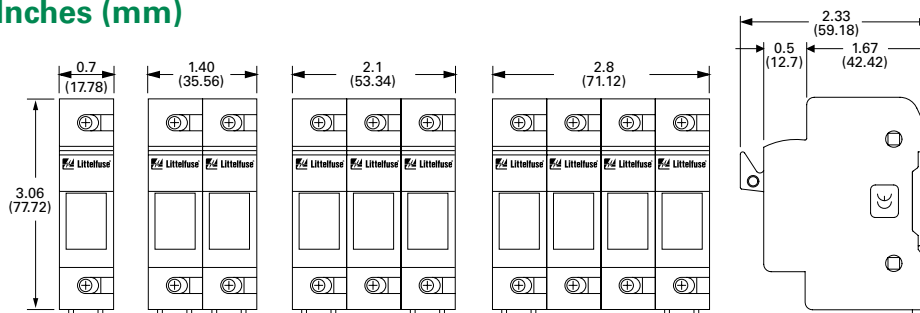

Specifications

Voltage Rating	1000 VDC
Amperage Rating	30 A
SCCR Rating	20 kA
Power Dissipation	4 W Maximum
Fuse Type	10 X 38 mm up to 1000 VDC
Housing Material	Thermoplastic
Terminal Screws	Zinc Plated Steel, Phillips/Slotted Head
Pressure Plate	Nickel Plated Steel
Fuse Clip Material:	Silver Plated Copper Alloy
Operating Temperature	-55°C to +125°C
Flammability Rating	UL94 V-0
Approval	Self-certified 1000 VDC IEC 60269-2, -4, -6
Environmental	RoHS compliant, Lead (Pb) Free

Web Resources

Sample requests, downloadable CAD drawings and other technical information: Littelfuse.com/lphv

More information about solar applications: Littelfuse.com/solar

Recommended Fuses

10x38 mm 1000 VDC Fuses	
SPF 1000 V Series	62
FLU 1000 V Series	31

ORDERING NUMBER	DESCRIPTION
CYHP001	20 Connector Pincers & 10 handle Pins
CYHP002	Connector Pincer Only
CYHP003	Handle Pin Only



Look for this logo to indicate products that are used in solar applications. Visit our website Littelfuse.com/solar for the latest updates on approvals, certifications, and new products.

LPSC / LPSM POWR-SAFE FUSE HOLDERS

600 V



Description

Littelfuse POWR-SAFE Dead Front holders provide optimum protection to personnel for Class CC and Midget-Style fuses.

Features/Benefits

- Indicating and non-indicating options available
- 1-, 2-, 3- and 4-pole configurations
- Easy installation and fuse removal with no additional pullers or tools required
- 35 mm DIN Rail Mountable
- Ventilated design for cooler operation

Specifications

Voltage Rating	600 Vac/dc
Ampere Rating	30 A
Interrupting Rating	200 kA (Class CC) 100 kA (Midget)
Terminal Type	Pressure plate
Suggested Torque	17.7 in-lbs
Wire Range	#8-#14 CU
Material	Thermoplastic
Flammability Rating	UL94 V-0
Approvals	UL Listed (LPSC File: E14721) UL Recognized (LPSM File: E14721) CSA Certified (LPSC/LPSM File: LR7316)
Environmental	RoHS compliant, Lead (Pb) Free

Dimensions Inches (mm)

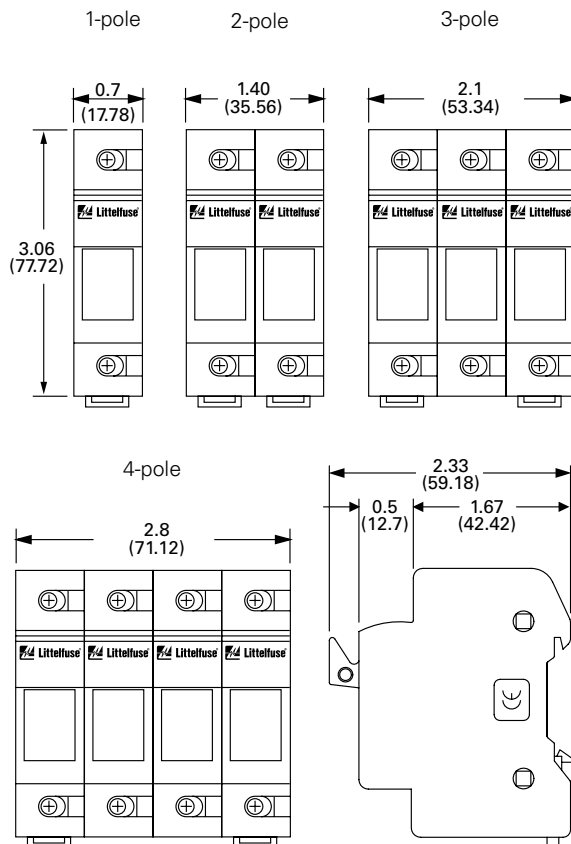

Ordering Information

INDICATING		NON-INDICATING		FUSE TYPE	POLES
CATALOG NUMBER	ORDERING NUMBER	CATALOG NUMBER	ORDERING NUMBER		
LPSC001ID	LPSC0001ZXID	LPSC001	LPSC0001Z	Class CC	1
LPSC002ID	LPSC0002ZXID	LPSC002	LPSC0002Z	Class CC	2
LPSC003ID	LPSC0003ZXID	LPSC003	LPSC0003Z	Class CC	3
LPSC004ID	LPSC0004ZXID	LPSC004	LPSC0004Z	Class CC	4
LPSM001ID	LPSM0001ZXID	LPSM001	LPSM0001Z	Midget	1
LPSM002ID	LPSM0002ZXID	LPSM002	LPSM0002Z	Midget	2
LPSM003ID	LPSM0003ZXID	LPSM003	LPSM0003Z	Midget	3
LPSM004ID	LPSM0004ZXID	LPSM004	LPSM0004Z	Midget	4

2-Pole Assembly Kit Ordering No. CYHP0001Z-KIT
(Kit contains 20 connector pincers & 10 handle pins.)

Web Resources

Download CAD drawings and other technical information:
littelfuse.com/lpsc
littelfuse.com/lpsm

Recommended Fuses

Class CC	27
Midget-Style (10 x 38 mm)	30

LFPSJ POWR-SAFE DEAD FRONT CLASS J FUSE HOLDERS

600 V



Description

Littelfuse Class J POWR-SAFE Dead Front holders provide optimum protection to personnel and are UL Listed and CSA Certified.

Features

- Indicating and non-indicating options available
- IP20 degree of protection
- Dual LED indication distinguishes polarity in DC power applications
- Small compact design offers ultimate flexibility
- 35mm DIN Rail Mountable
- 1-, 2-, and 3-pole configurations
- Easy installation and fuse removal with no additional pullers or tools required

Dimensions mm (inches)

30 Amp

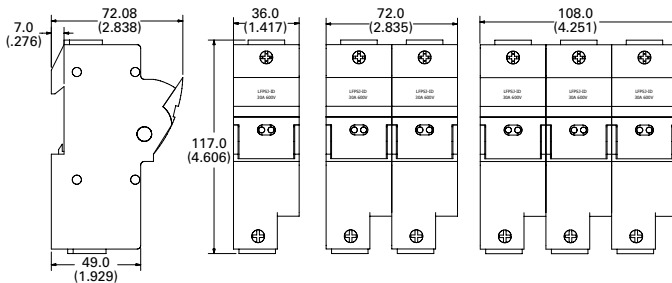

60 Amp

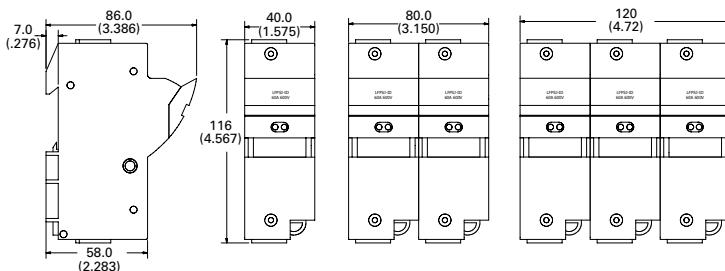

Note: These dimensions are for reference only. Please contact factory for additional information.

Specifications

Voltage Ratings	600 Vac/dc
Interrupting Rating	200 kA
Ampere Rating	30 and 60 A
LEDs	110 V – 600 V
Terminal Type	Pressure Plate
Material	Thermoplastic
Flammability Rating	UL94 V-0
Terminal Screws	Phillips / Slotted
Approvals	UL Listed (File: E14721) CSA Certified (File: 2529839)
Environmental	RoHS compliant

Ordering Information

AMP	POLES	INDICATION	ORDERING NUMBER	PACK QTY.	WIRE TYPE	WIRE RANGE	TORQUE
30	1	–	LFPSJ301.Z	6	Stranded	0.75mm ² – 1mm ² 1.5mm ² – 50mm ² 18 – 1 AWG	2.5 N-m 4.0 N-m 35 lb-in
	2	–	LFPSJ302.Z	3			
	3	–	LFPSJ303.Z	2			
30	1	•	LFPSJ301.ZXID	6			
	2	•	LFPSJ302.ZXID	3			
	3	•	LFPSJ303.ZXID	2			
60	1	–	LFPSJ601.Z	6	Stranded	2.5mm ² – 50mm ² 14 – 1 AWG	4.0 N-m 35 lb-in
	2	–	LFPSJ602.Z	3			
	3	–	LFPSJ603.Z	2			
60	1	•	LFPSJ601.ZXID	6			
	2	•	LFPSJ602.ZXID	3			
	3	•	LFPSJ603.ZXID	2			

Multi-Pole Assembly Kit

Kits are used to create multi-pole holders from 1-pole LFPSJ fuse holders. Please contact factory for more information.

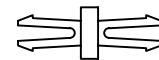

Connector Pincer



Handle Pin

AMP	POLES	PINCER QUANTITY	PIN QUANTITY	ASSEMBLY SETS	ORDERING NUMBER
30	2	30	10	10	LF3J2PAK
30	3	60	10	10	LF3J3PAK
60	2	30	10	10	LF6J2PAK
60	3	60	10	10	LF6J3PAK

Web Resources

Download CAD drawings and other technical information:
littelfuse.com/lfpsj

Recommended Fuses

Class J - JTD, JTD_ID, JLS 21

BUS BAR SYSTEM

POWR-BAR Distribution



Description

A key objective for panel designers is safe distribution of power to multiple fuse holders in a compact design. The Littelfuse UL 508 Listed bus bar system eliminates most wire terminations in a timesaving package. A power distribution block and associated conductors are no longer needed to feed multiple POWR-SAFE fuse holders.

Features/Benefits

- Touch-safe design offers protection when replacing fuses
- Compact design
- 35 mm DIN Rail Mountable
- Available in one and three phase configurations
- No fuse pullers or tools required for fuse removal
- Can be cut down to optimal size

Recommended Fuse Holders

LPSM / LPSC (600 Vac/dc).....	117
LPHV (1000 Vdc)	116

Web Resources

Download CAD drawings, dimensions and other technical information: littelfuse.com/busbar

Specifications

Voltage Ratings 600 Vac/dc
 1000 Vdc*

Current Ratings

CROSS SECTION (mm ²)	18 mm ²	25 mm ²
END FED	80 A	100 A
CENTER FED	160 A	200 A

SCCR 10 kA, 100 kA¹
Conductor Copper
Pitch 17.8 mm
Approvals UL 508 Listed (File E328654)
Environmental RoHS Compliant, Lead (Pb) free

*1 Phase 18 mm² rated 1000 Vdc up to 160 A when center fed
 1 Phase 25 mm² rated 1000 Vdc up to 200 A when center fed
¹ When protected directly upstream by Class J 175 amperes max (18 mm² bus bar) and Class J 200 amperes max (25 mm² bus bar).

Ordering Information

1 PHASE, 18 mm ²			1 PHASE, 25 mm ²		
ORDERING NUMBER	POLES	LENGTH (mm)	ORDERING NUMBER	POLES	LENGTH (mm)
1PH3P18mm	3	50	1PH3P25mm	3	50
1PH4P18mm	4	79	1PH4P25mm	4	79
1PH6P18mm	6	104	1PH6P25mm	6	104
1PH9P18mm	9	155	1PH9P25mm	9	155
1PH12P18mm	12	208	1PH12P25mm	12	208
1PH15P18mm	15	270	1PH15P25mm	15	270
1PH57P18mm	57	1009	1PH57P25mm	57	1009

3 PHASE, 18 mm ²			3 PHASE, 25 mm ²		
ORDERING NUMBER	POLES	LENGTH (mm)	ORDERING NUMBER	POLES	LENGTH (mm)
3PH6P18mm	6	104	3PH6P25mm	6	104
3PH9P18mm	9	158	3PH9P25mm	9	158
3PH12P18mm	12	214	3PH12P25mm	12	214
3PH15P18mm	15	266	3PH15P25mm	15	266
3PH57P18mm	57	1009	3PH57P25mm	57	1009

Endcaps are standard with all 3 phase configurations except 57-pole. Endcaps are not needed for the 1 phase configurations from the factory or if the copper bus is trimmed per the supplied instructions. Power feed lugs and protective covers are extra.

Accessories

Power Feed Lug

PART NUMBER	WIRE RANGE	WIRE TYPE	TORQUE	PHASE	FUSE HOLDER
BB17	#10 - 1/0 AWG	CU	50 lb-in	Single	LPSM/LPSC/LPHV
BB18	#10 - 1/0 AWG	CU	50 lb-in	Three	LPSM/LPSC
BB19	#10 - 1/0 AWG	CU	50 lb-in	Single	LFPSP/LFPSC
BB20	#10 - 1/0 AWG	CU	50 lb-in	Three	LFPSP/LFPSC

Power Feed Lugs are 115A 1000V AC/DC rated

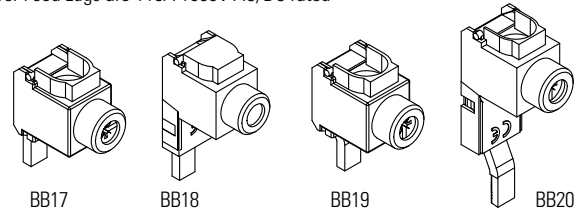

Endcaps

PART NUMBER	PHASE	QUANTITY
EDCP42	Single	50
EDCP7	Three	50

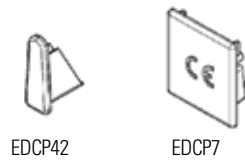

Pole Protective Covers

PART NUMBER	QUANTITY
CTPT5	5



LPSM QUICK CONNECT POWR-SAFE FUSE HOLDERS



Description

The LPSM midget fuse holder series is a dead front design providing protection to personnel when installing and removing fuses. The compact fuse holder mounts quickly onto 35 mm DIN rail, decreasing panel layout and assembly time. This product has two Quick Connect terminals on both the top and bottom of the holder, offering an additional connection option. It is available in 1-, 2-, 3- and 4-pole configurations.

Features/Benefits

- Dual 1/4" Quick Connect Terminals on Top and Bottom of Holder
- Meets Dead Front requirements
- Mountable on 35 mm DIN Rail
- Local LED Indication

Dimensions mm (inches)

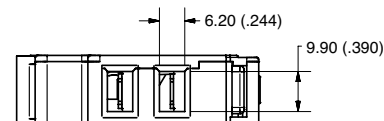
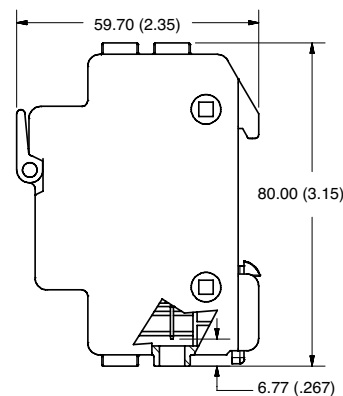
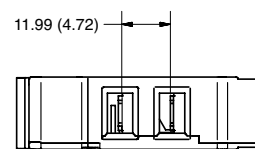
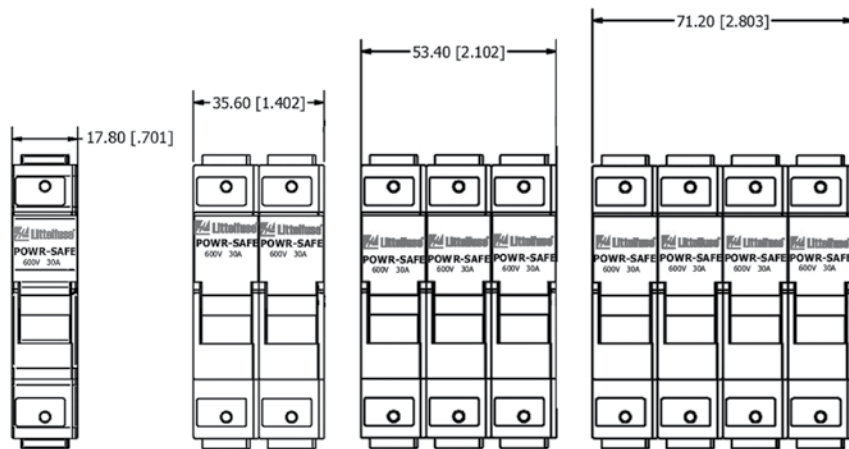

Specifications

Voltage Rating	600 Vac/dc
Amperage Rating	30 A
Approval	UL Recognized (File No. E14721) CSA Certified (File No. LR7316) IEC 60269-2 CCC Approved
Terminal Type	1/4" Quick Connect Terminals
Fuse Type	Midget (10 X 38 mm) series
Material	Thermoplastic
Flammability Rating	UL94 V-0
SCCR Rating	Same as Fuse Rating

Ordering Information

POLES	CATALOG NUMBER	ORDERING NUMBER
1	LPSM001QCID	LPSM0001ZQCID
2	LPSM002QCID	LPSM0002ZQCID
3	LPSM003QCID	LPSM0003ZQCID
4	LPSM004QCID	LPSM0004ZQCID

2-Pole Assembly Kit Ordering No. CYHP0001Z-KIT
(Kit contains 20 connector pincers & 10 handle pins.)

Recommended Fuses

Midget-Style (10x38mm) 30

Web Resources

Download CAD drawings and other technical information:
littelfuse.com/lpsmqc

354 SERIES 3AG OMNI BLOCK®

Molded Base Type Fuse Block



Description

A low profile fuse block featuring individual barriers that reinforce the fuse clips while providing greater protection against clip damage and electrical shock. The unique design permits self-alignment of clips to fuse cap. This, plus a one-piece clip/terminal, assures low contact resistance.

Specifications

- Dielectric Strength** 1500 V Minimum
- Clip/Terminals** Tin-Plated Spring Brass; two different style clips can be supplied for circuit identity or polarization
- Base** Glass reinforced Thermoplastic:
Gray except anti-rotation series which is black
- Flammability Rating** UL94 V-0
- Ambient Temperature** -40°C to +85°C

Dimensions Inches

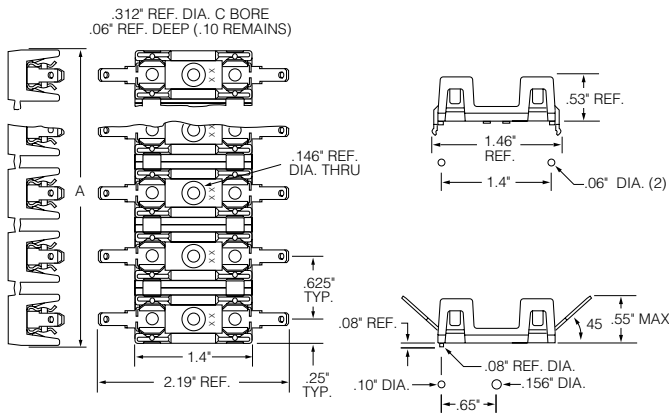

Ordering Information

CATALOG NUMBER	TERMINALS	VOLTAGE	CURRENT RATING	
			UL	CSA
354 000	Solder	600VAC/VDC*	30 A	30 A
354 600	3/16" Q.C.	600VAC/VDC	20 A	20 A
354 800	1/4" Q.C.	600VAC/VDC	20 A	20 A
354 900	1/4" Q.C.	600VAC/VDC	30 A	25 A
354 101-GY	P.C. Board	600VAC/VDC	15 A	15 A

*30 A capability is based on temperature rise with #10 AWG wire properly soldered.

Recommended Fuses

3AG Cartridge 34

Web Resources

For additional technical information visit: littelfuse.com

Technical Information

SOLDER TYPE TERMINALS	3/16" Q.C. TERMINALS†	1/4" Q.C. TERMINALS	1/4" Q.C. TERMINALS†	POLES	DIM "A"
354 001GY	354 601GY	354 801GY	354 901GY	1	.50"
354 002GY	354 602GY	354 802GY	354 902GY	2	1.12"
354 003GY	354 603GY	354 803GY	354 903GY	3	1.75"
354 004 GY	354 604GY	354 804GY	354 904GY	4	2.38"
354 005GY	354 605GY	354 805GY	354 905GY	5	3.00"
354 006GY	354 606GY	354 806GY	354 906GY	6	3.63"
354 007GY	354 607GY	354 807GY	354 907GY	7	4.25"
354 008GY	354 608GY	354 808GY	354 908GY	8	4.88"
354 009GY	354 609GY	354 809GY	354 909GY	9	5.50"
354 010GY	354 610GY	354 810GY	354 910GY	10	6.13"
354 011GY	354 611GY	354 811GY	354 911GY	11	6.75"
354 012GY	354 612GY	354 812GY	354 912GY	12	7.38"
354 021BL*	354 621BL*	354 821BL*	354 921BL*	1	.50"
354 101GY	—	—	—	1	.50"

† NEMA style
* With Anti-Rotation Boss

FUSE PULLERS & POWR-JAW CLIP CLAMPS

MFP • LPFP • GFP • 097023



Features/Benefits

- Ergonomically designed fuse pullers designed to safely remove power fuses
- Molded design offers more comfortable and natural grip than traditional pullers, increasing performance

Specifications

TYPE OF FUSE PULLER	PART NUMBER	FUSE SIZE (DIAMETER)
Midget Fuse	MFP	3/16" - 1/2" fuses
Pocket Fuse	LPFP	250 V fuses from 0-200 A 600 V fuses from 0-100 A 9/16" - 1 1/32" fuses
Giant Fuse	GFP	250 V fuses from 61-600 A 600 V fuses from 61-400 A 1 1/16" - 2 19/32" fuses
Tri-puller	097023	For ATO, MINI and glass fuses

Web Resources

For additional technical information visit:
littelfuse.com/fusepullers

LCC Series POWR-JAW



Features/Benefits

- Improve contact between fuse and clip
- Help prevent unnecessary heat from poor contact due to the loss of spring force. This reduces:
 1. Nuisance fuse opening
 2. Premature aging of surrounding components
- High temperature phenolic resin knob for durability
- Wide range of coverage with simple design

Ordering Information

CATALOG NUMBER	ORDERING NUMBER	VOLTS	AMPERES
LCC1	0LCC1	250	0-30
LCC2	0LCC2	250	35-60
LCC2	0LCC2	600	0-30
LCC4	0LCC4	600	35-60
LCC5	0LCC5	250 or 600	70-100
LCC6	0LCC6	250 or 600	110-200
LCC7	0LCC7	250 or 600	225-400
LCC8	0LCC8	250 or 600	450-600

*Note: POWR-JAW Clip Clamps are sold individually, not in pairs.
A minimum of 1/8" of clearance between the fuse block barrier and fuse clip is required to install Clip Clamps.*

Web Resources

For additional technical information visit:
littelfuse.com/clipclamps

LFFB SERIES LIMITER BLOCK / LHFB INLINE HOLDER

LFFB



Dimensions mm (inches)

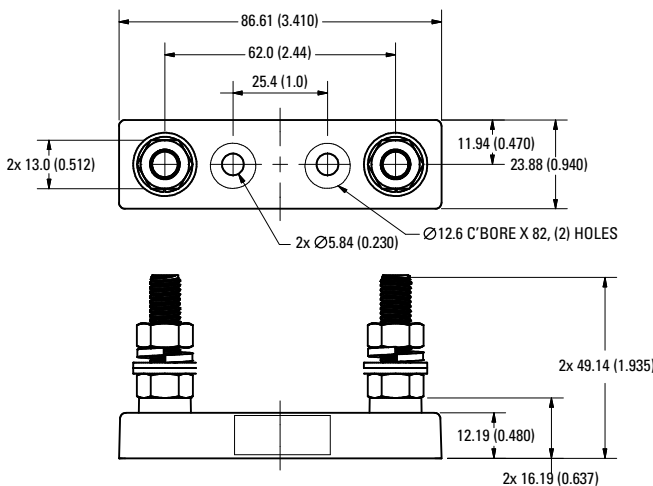

Description

The LFFB series fuse block is designed to accept bolt-down style limiter fuses. Applications include but are not limited to forklifts, golf carts and other low-voltage battery equipment. It is specifically designed for the HAZGARD™ fuse but can be used for CNN and CNL series fuses as well.

Specifications

Voltage Rating	150 Vac/Vdc
Ampere Rating	800 A
Approvals	UL Recognized (File: E14721)
Construction	Base—Thermoplastic Studs—Steel Zinc Plated

Ordering Information

CATALOG NUMBER	ORDERING NUMBER
LFFB003	LFFB0003Z

Web Resources

Sample requests and other technical information:
littelfuse.com/lffb

Recommended Fuses

CNL/CNN/CNN_E Fork Lift fuses.....	64
HAZGARD (581 series) fuse	64

LHFB



Description

The Littelfuse LHFB waterproof in-line fuse holder is ideal for harsh environments. The LHFB holder features the voltage and ampere rating molded into the body, along with a wire strip gauge. It also withstands solvents and vibration.

Features/Benefits

- Waterproof in-line fuse holder for harsh environments
- One-piece molded thermoplastic body
- Bright green color offers high visibility
- Voltage and ampere rating molded into body

Specifications

Voltage Rating	32 V
Ampere Rating	30 A
Fuses	1/4" x 1/4" fuses
Wire Size	Accepts #16 to #18 gauge wire
Operating Temperature	-20° C to 80° C

Installation Instructions

1. Thread wire through fuse holder body
2. Strip wire insulation per strip gauge
3. Crimp wire to fuse clip*
4. Pull wire through and seat fuse clip in the holder body
5. Insert desired fuse type and rating
6. Snap holder body together

*Recommended crimping tools: Thomas & Betts No. WT-111M
Note: Wire is not supplied with the holder.

Web Resources

Sample requests and other technical information:
littelfuse.com/lhfb

571 & 572 SERIES PANEL-MOUNT FUSE HOLDERS

571



Description

Panel mount fuse holders are for Midget-Style and Class CC fuses. Class CC fuses have a rejection feature on one end cap, which mates with the rejection feature of Littelfuse Class CC fuses holders to prevent the installation of fuses with lower voltage ratings or interrupting ratings. Watertight version must be front panel mounted.

Dimensions Inches (mm)

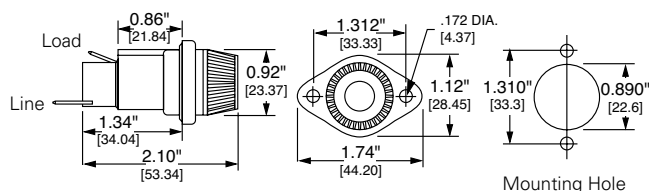

Ordering Information

CATALOG/ORDERING NUMBER				BOTTOM TERMINAL	FUSE LENGTH RANGE*	FOR USE WITH
STANDARD	WATERTIGHT					
571027	05710027L	571027P	05710027LXP	Straight	1 ⁵ / ₁₆ " – 1 ³ / ₈ "	Midget Fuses
571028	05710028L	571028P	05710028LXP	Rt. Angle		
571007	05710007L	571007P	05710007LXP	Straight	1 ¹³ / ₃₂ " – 1 ¹ / ₂ "	Midget Fuses
571008	05710008L	571008P	05710008LXP	Rt. Angle		
5710CC	057100CCL	5710CCP	057100CCLXP	Straight	1 ¹ / ₂ "	Class CC Fuses
571RCC	05710RCCL	571RCCP	05710RCCLXP	Rt. Angle		

*Fuse diameter is 13/32"

Note: Contact factory for versions with pre-assembled wire leads.

Specifications

Voltage Rating	600 V
Ampere Rating	30 A for Class CC and Midget fuses
Dielectric Strength	4000 V Minimum
Terminals	Tin-plated brass combination solder & quick-connect
O-Rings	901-184 (body), 901-260 (knob)
Molded Parts	Black thermoplastic
Approvals	UL Recognized (File: E14721) UL Recognized for branch circuit protection (5710CC/RCC) CSA Certified (File: LR7316)

Web Resources

Additional technical information: littelfuse.com/571

572



Description

The 572 series panel mount fuse holders are designed to minimize installation time. Its unique design incorporates a snap-mount feature that allows the holder to be installed without any tools or mounting hardware.

Dimensions Inches (mm)

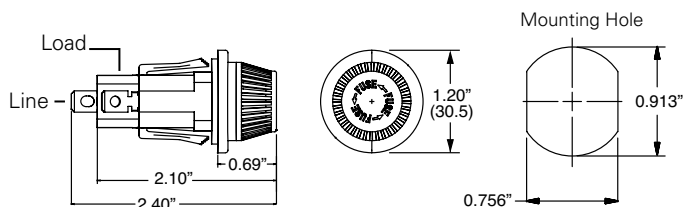

Ordering Information

CATALOG/ORDERING NUMBER				BOTTOM TERMINAL	FUSE LENGTH RANGE†	FOR USE WITH
STANDARD	WATERTIGHT					
572027	05720027L	572027P	05720027LXP	Straight	1 ⁵ / ₁₆ " – 1 ³ / ₈ "	Midget Fuses
572028	05720028L	572028P	05720028LXP	Rt. Angle		
572007	05720007L	572007P	05720007LXP	Straight	1 ¹³ / ₃₂ " – 1 ¹ / ₂ "	Midget Fuses
572008	05720008L	572008P	05720008LXP	Rt. Angle		
5720CC	057200CCL	5720CCP	057200CCLXP	Straight	1 ¹ / ₂ "	Class CC Fuses
572RCC	05720RCCL	572RCCP	05720RCCLXP	Rt. Angle		

†Fuse diameter is 13/32"

Note: Contact factory for versions with pre-assembled wire leads.

Specifications

Voltage Rating	600 V
Ampere Rating	30 A for Class CC and Midget fuses
Dielectric Strength	4000 V Minimum
Terminals	Tin-plated brass combination solder & quick-connect
Molded Parts	Black thermoplastic
Approvals	UL Recognized (File: E14721) UL Recognized for branch circuit protection (5720CC/RCC) Class CC version CSA Certified (File: LR7316)
Mounting	Double "D" punch - Greenlee #61092 (14-18 gauge panel thickness recommended)

Web Resources

Additional technical information: littelfuse.com/572

342 SERIES 3AG (1/4" X 1 1/4") PANEL MOUNT FUSE HOLDERS

Traditional Panel Mount Type



Straight Terminal
Knurled Knob



Right Angle
Terminal
Fluted Knob

Description

Panel Mount Fuse holders for 3AG (1/4" x 1 1/4") fuses. Both fluted and knurled knob terminal options are available.

Ordering Information

Straight Terminal

FLUTED KNOB		KNURLED KNOB		TERMINAL
CATALOG/ORDERING NUMBER		CATALOG/ORDERING NUMBER		
342014A	03420014X	342012A	03420012X	Solder
342038A	03420038X	342058A	03420058X	3/16" Q.C.
342838A	03420838X	342858A	03420858X	1/4" Q.C.

Specifications

Electrical	Rated at 20 A for any voltage up to 250 V
Dielectric Strength	2400 V minimum
Mounting	Withstands 15 lb-in mounting torque; maximum panel thickness .187"
Molded Parts	Black thermoplastic (UL94 V-0)
Knob	Bayonet style with lettering
Terminals	Copper & copper alloy. Tin plated, except 1/4" Quick-Connect terminals are nickel plated
Ambient Temperature	-40°C to +85°C

Recommended Fuses

3AG Cartridge	34
---------------------	----

Web Resources

Additional technical information available at:
littelfuse.com/342

Right Angle Terminal

FLUTED KNOB		KNURLED KNOB		TERMINAL
CATALOG/ORDERING NUMBER		CATALOG/ORDERING NUMBER		
342004	03420004X	342022A	03420022X	Solder
342028A	03420028X	342048A	03420048X	3/16" Q.C.
342828	03420828X	342848A	03420848X	1/4" Q.C.

Straight Terminal

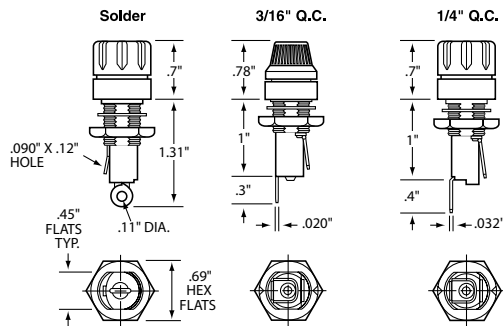

Right Angle Terminal

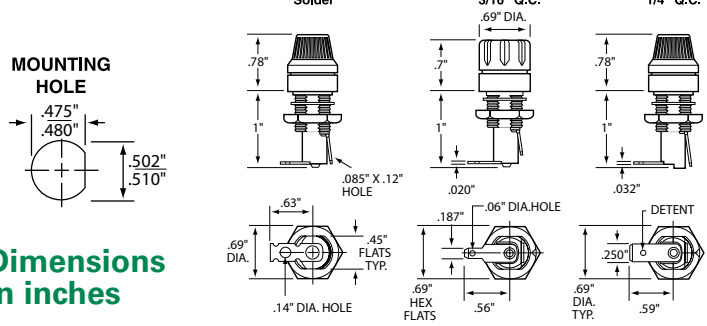

Dimensions in inches

342 Series (Watertight Panel Mount Type)



Dimensions Inches

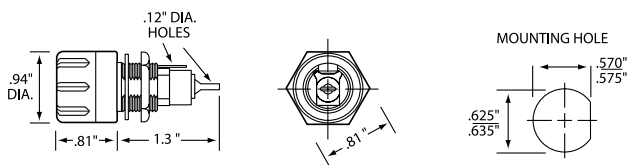

Specifications

Electrical	Rated at 20 A for any voltage up to 250 V
Dielectric Strength	1500 V minimum
Mounting	Withstands 15 lb-in mounting torque; maximum panel thickness is .250"
Molded Parts	Black thermoset (UL94 V-0)
Knob	Screw type
Seal	O-ring provides a watertight seal on the front side of the panel per MIL-PRF-19207
Terminals	Copper & copper alloy. Tin plated. Solder type
Ambient Temperature	-40°C to +85°C
Hardware	O-rings (2) and hex nut, unassembled

Ordering Information

CATALOG NUMBER	ORDERING NUMBER
342006A	0342006ZXA

Recommended Fuses

3AG Cartridge	34
---------------------	----

Web Resources

Additional technical information available at: littelfuse.com/342

345 SERIES PANEL MOUNT FUSE HOLDERS

International Shock-Safe Panel Mount Type



Description

Designed to eliminate electrical shock as defined by IEC Standards 60065 and 60127, these panel-mount fuse holders offer a wide variety of options. This allows for inventory reduction and versatility.

Features/Benefits

- Anti-tease feature eliminates circuit interruption when knob is accidentally depressed
- Five fuse holder types for maximum flexibility
- Two knob styles—screwdriver slot and finger grip
- Drip proof option available on screwdriver slot knob style
- Two terminal choices depending on application



Web Resources

For more informations, visit:
littelfuse.com/shocksafe

Recommended Fuses

Glass / Electronic Fuses..... 33

Specifications

Insulation Resistance 10,000 megaohm minimum at 500 Vdc
Contact Resistance Less than .005 ohm average at currents up to 1 A
Mounting Threaded styles withstand 15 in-lb mounting torque
 Profile panel thickness .032" min/310" max.
 Quick mount panel thickness .012" min/360" max.
 Rear mount panel thickness .012" min/260" max.
Body Material Black glass-filled thermoplastic (UL94 V-0)
Knob Material Grey, blue or black glass-filled thermoplastic (UL94 V-0)
Hex Nut Material Black glass-filled thermoplastic
Knob Finger-Grip, Fuse Extractor type or Screwdriver Slot, Fuse Extractor type with plated copper alloy insert
 Plated copper alloy contact clips.
 Spring loaded, locking mechanism provides an anti-tease feature and will not vibrate loose
Terminals Copper alloy, Tin-plated
Ambient Temperature -40°C to +85°C
Hardware Threaded style fuse holders are supplied with a thermoplastic hex nut unassembled
 Quick mount style fuse holders are supplied with a push-on type retaining nut, black oxide finish, unassembled
 A synthetic rubber O-ring will be supplied only with the screwdriver slot knob when the drip-proof version is requested

AGENCY APPROVAL	FILE NUMBER	3AG	5 X 20 mm	2AG
UL	E75961	20 A 250 V	10 A 250 V	10 A 250 V
CSA	LR91788	20 A 250 V	10 A 250 V	10 A 250 V
VDE	116895E	10 A 250 V	10 A 250 V	—

Note: To order with a metal internal tooth lockwasher (L) and/or neoprene panel washer (N) and/or drip-proof synthetic rubber "O" ring with Neoprene washer (NP) [Screwdriver slot knob only], add the appropriate suffix (L, N, or NP) respectively.

Please refer to Technical Application Guide section for information on proper fuse holder de-rating.

Ordering Information

EXAMPLE:
(Complete Assembly with Options)

Series Number **345 3 LS 7 LNP**

FUSE SIZE	STYLE	TERMINALS	OPTIONS*
2 2AG .177" x .570"	LF Low Profile Body Black Fingergrip Knob	1 3/16" (Right Angle) Dual Purpose Solder/QC	L Lockwasher
3 3AG .250" x 1.250"	RF Rear Mount Body Black Fingergrip Knob	2 3/16" (Straight) Dual Purpose Solder/QC	N Neoprene Washer
5 5 x 20 mm .197" X .787"	HS High Profile Body Screwdriver Slot Knob	3 3/16" (Right Angle) NEMA QC	NP Drip-Proof O-Ring [†] with Neoprene Washer
	LS Low Profile Body Screwdriver Slot Knob	4 3/16" (Straight) NEMA QC	
	OS Quick Mount Body Screwdriver Slot Knob	7 1/4" (Right Angle) NEMA/DIN QC	
	Screwdriver Slot Knob 2AG—Blue Knob 3AG—Grey Knob 5 x 20 mm—Black Knob	8 1/4" (Straight) NEMA/DIN QC	

*Options (L, N, NP) can be ordered individually or in combination.
[†]Screwdriver slot knob only.

LSCR SERIES HIGH-SPEED FUSE BLOCKS

700 V/1000 V



Description

Littelfuse LSCR Series is a comprehensive line of modular fuse blocks, designed to accommodate a wide range of High-Speed and UL Power Fuses. These LSCR Series blocks have modular stud type design that enables easy mounting in panel boards.

LSCR Series blocks are CE Certified and RoHS Compliant.

Features/Benefits

- Modular design reduces inventory requirements
- Sold in pairs for convenience
- Supplied with nut and Belleville washer
- 200kA short-circuit withstand rating
- Constructed of molded phenolic (with plated steel studs) provide greater heat dissipation

Specifications

Voltage Rating	700 V / 1000 V
Ampere Ratings	400A, 800A and 1200A
Withstand Rating	200kA
Approvals	UL Recognized (File: E14721) cURus Recognized (E14721) CSA Certified (File: 73160)
Material	Base: Molded Phenolic or Thermoplastic Terminal Construction: Plated steel.
Flammability Rating	UL94 V-0
Environmental	RoHS Compliant
Country of Origin	LSCR0xx - China LSCR1xx - USA

Web Resources

For more information, visit: littelfuse.com/lscr

6

Fuse Blocks and Holders

ELECTRICAL & MECHANICAL SPECIFICATIONS

CATALOG/ ORDERING NUMBER	AMPERE RATING	VOLTAGE RATING	TERMINAL (STUD) MATERIAL	INSULATOR		TERMINAL (STUD) SIZE	STUD TORQUE		MOUNTING FASTNER SIZE	FASTENER TORQUE		AGENCY APPROVALS		
				MATERIAL	MAX. BASE TEMPERATURE		(in.lbs)	(N-m)		(in.lbs)	(N-m)	UR	CURUS	CSA
LSCR001	400A	700Vac/dc	Plated Steel	Molded Phenolic	150°C (302°F)	¼-20 UNC	61	6.9	#10	20-25	2.3-2.8	•		•
LSCR002	800A	700Vac/dc	Plated Steel	Molded Phenolic	150°C (302°F)	3/8-16 UNC	192	21.7	#10	20-25	2.3-2.8	•		•
LSCR101	400A	1000Vac/dc	Steel, Zinc Plated	Thermoplastic	125°C (257°F)	¼-20 UNC	75	8.5	#10	25-30	2.8-3.4		•	
LSCR102	800A	1000Vac/dc	Steel, Zinc Plated	Thermoplastic	125°C (257°F)	3/8-16 UNC	230	26	#10	25-30	2.8-3.4		•	
LSCR103	1200A	1000Vac/dc	Steel, Zinc Plated	Thermoplastic	125°C (257°F)	½-13 UNC	300	34	¼"	25-30	2.8-3.4		•	

LSCR SERIES HIGH-SPEED FUSE BLOCKS

Dimensions mm (inches)

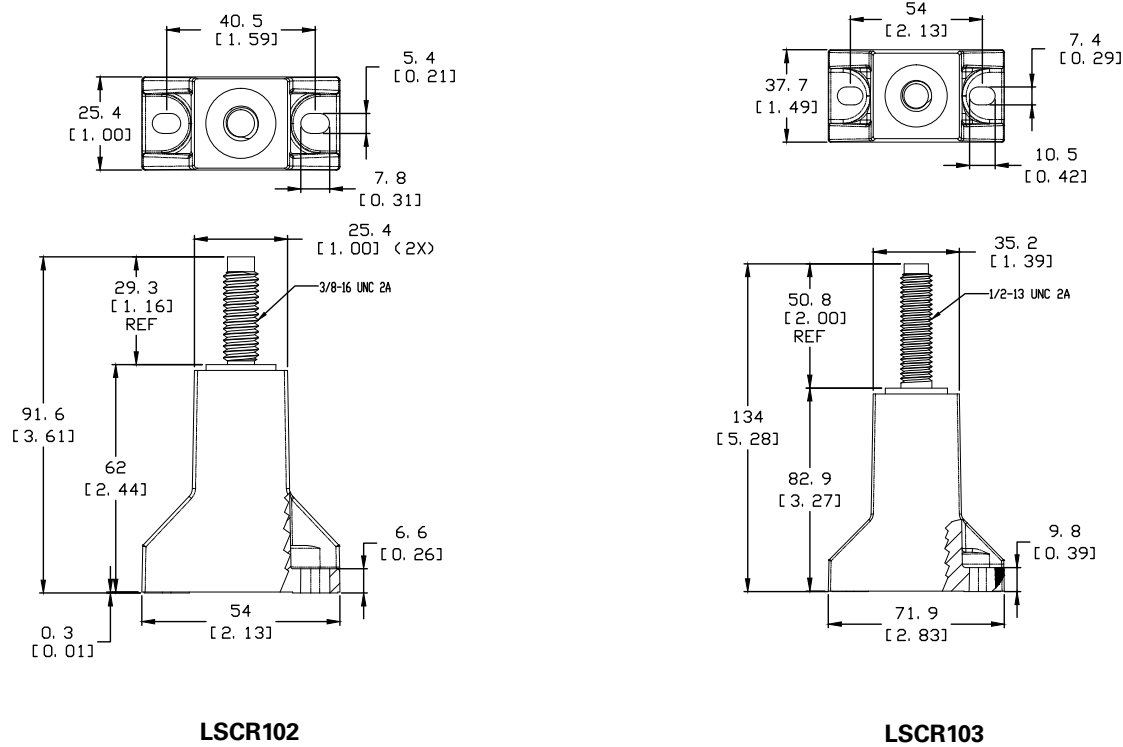
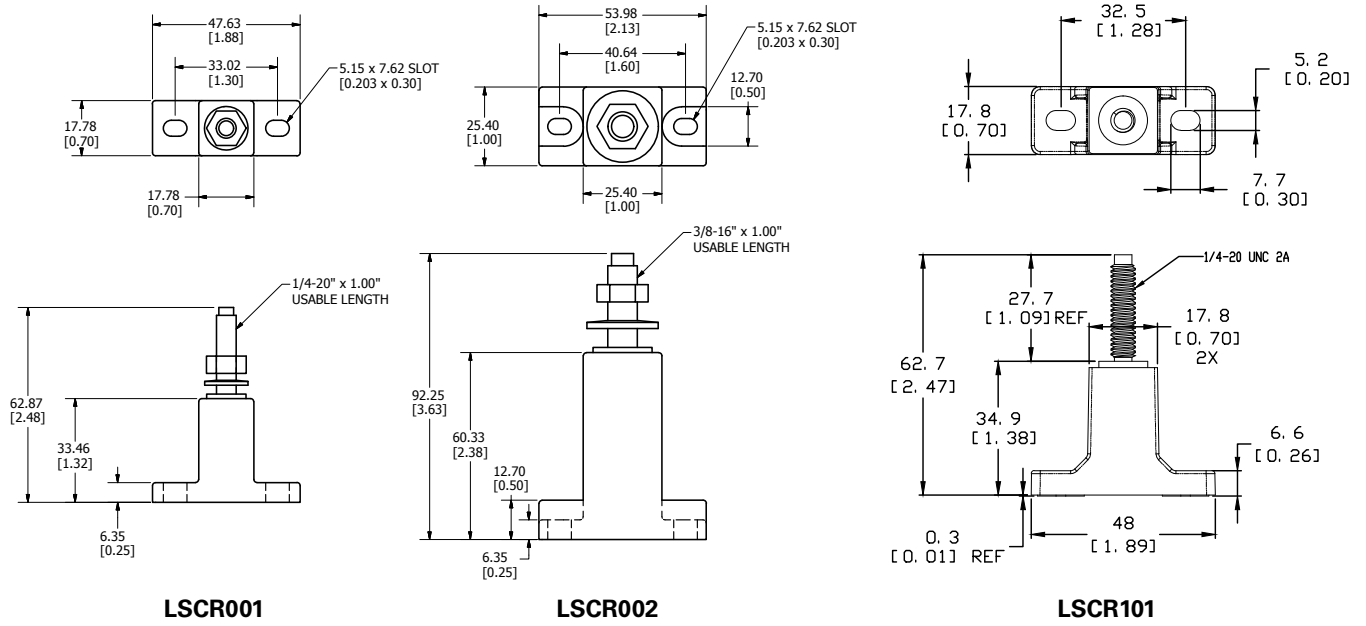

1LFS SERIES HIGH-SPEED FUSE BLOCKS

600V • 1-400 A



Specifications

Voltage Rating	600 V
Ampere Range	1 – 400 A
Approvals	UL Recognized E14721
Material	Base: 150° C general purpose phenolic Terminal: Tin plated aluminum

Web Resources

Download CAD drawings and other technical information:
littelfuse.com/1fs

Description

Littelfuse modular style high-speed semiconductor fuse blocks accommodate a wide range of semiconductor fuses. Blocks are provided in pairs with fuse mounting hardware.

Features/Benefits

- Modular design reduces inventory requirements
- Sold in pairs for convenience
- Constructed of general purpose phenolic (with tin plated aluminum terminations)

Ordering Information

CATALOG NUMBER	AMPERE RATING	WIRE RANGE	WIRE RATING	APPROVALS
1LFS101	100 A	#2/0 - 14 CU/AL	120 in-lbs	UL Recognized
1LFS102	400 A	250MCM - #6 CU/AL	275 in-lbs	UL Recognized

Recommended Fuses

1LFS101

FUSE SERIES	AMPERE RATINGS
L15S	70-100
L25S	35-100
L50S	35-100
L60S	35-100
KLC	1-100

1LFS102

FUSE SERIES	AMPERE RATINGS
L15S	70-400
L25S	70-200
L50S	125-200
L60S	125-200

Dimensions Inches (mm)

1LFS101

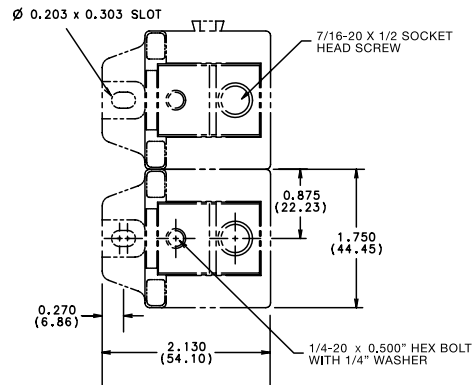

1LFS102

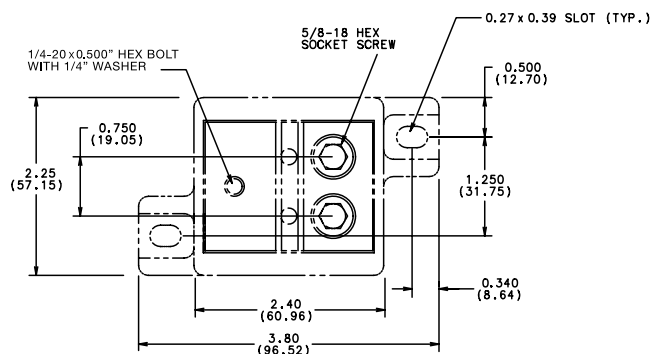

POWR-BLOKS

Distribution Blocks • Splicer Blocks • Covers



Description

POWR-BLOKS power distribution blocks offer a safe, convenient way of splicing cables, providing a fixed junction tap-off point or splitting primary power into secondary circuits. Lx2xxx-DIN series offers integral DIN-Rail mount and an optional hinged safety cover.

Optional power distribution block covers provide protection against accidental shorting between poles caused by loose wires, tools, or other conductive material. They also protect personnel from accidentally contacting energized connectors.

Applications

Typical applications include heating, air conditioning and refrigeration systems, elevator systems, material handling equipment, control panels, motor controls, switchgear, and anywhere power needs to be distributed to more than one load.

Connectors

Box lug connectors are designed for use with a single or multiple, solid or class B or C stranded conductor. For UL approved use of more than one conductor per connector opening, contact Littelfuse Technical Service. Manufacturers of cable terminations can furnish crimp-on sleeves for fine stranded conductors which permit these conductors to be used with box lugs.

Ampere Ratings

The ampere rating per pole for power distribution blocks is based on the line ampacity of 75°C insulated conductors per NEC® Table 310.16. If 60°C insulated conductors are used, load must not exceed the ampacity of 60°C conductors. Use of conductors rated in excess of 75°C is permitted (for example 90°C), however, load must not exceed the ampacity of 75°C conductors.

Specifications

Voltage Rating	600 V
Current Rating	Based on NEC Table 310.16, using 75°C copper wire
SCCR	Consult Factory
Material	Phenolic rated at 150°C and Thermoplastic rated at 125°C (LD1400 and LS1300 series only)
Connector	Aluminum: Highly conductive aluminum, tin plated Copper: Highly conductive copper, tin plated
Flammability Rating	UL94 V-0
Approvals	UL Recognized - OLD/OLS Series (File: E171395) LFD/LFS Series (File: E309688) CSA Certified - OLD/OLS Series (File: LR700111) LFD/LFS Series (File: 007316_0_000) UL Listed - OLD57xxxx (File: E482231)
Environmental	RoHS compliant, Lead (Pb) free

Ordering Information

See Selection Guide on next page

Web Resources

For dimension, CAD and 3-D drawings, visit:
Littelfuse.com/powrbloks

Hinged Plastic Covers



Clear Plastic Covers



POWR-BLOKS

Distribution Block Selection Guide

AMP PER POLE	POLES	CONNECTOR MATERIAL	LINE CONNECTION				LOAD CONNECTION				FIGURE	CATALOG/ORDERING NUMBER	*PLASTIC COVER ORDERING NUMBER			
			CONNECTOR IMAGE	OPENINGS PER POLE	LUG TYPE	WIRE RANGE	TORQUE RANGE	CONNECTOR IMAGE	OPENINGS PER POLE	LUG TYPE				WIRE RANGE	TORQUE RANGE	
115	1	AL		1	Slotted	#2 - #14	35-50 in-lbs		4	Slotted	#10 - #18	7 in-lbs	10	OLD14401Z	LPBC1441	
115	2			1	Slotted	#2 - #14	35-50 in-lbs		4	Slotted	#10 - #18	7 in-lbs	10	OLD14402Z	LPBC1442	
115	3			1	5/32" Hex	#2 - #14	50-40 in-lbs		4	5/64" Hex	#10 - #18	7 in-lbs	2	LFD14003Z	LPBC13	
115	4			1	Slotted	#2 - #14	35-50 in-lbs		4	Slotted	#10 - #18	7 in-lbs	10	OLD14404Z	LPBC1444	
175	1	AL		1	5/16" Hex	2/0 - #14	35-120 in-lbs		4	Slotted	#4 - #14	35 in-lbs	3	OLD25701Z	LPBC21	
175	2			1	3/16" Hex	2/0 - #14	40-120 in-lbs		4	1/8" Hex	#4 - #14	35 in-lbs	3	LFD25702Z	LPBC22	
175	3			1	3/16" Hex	2/0 - #14	40-120 in-lbs		4	1/8" Hex	#4 - #14	35 in-lbs	3	LFD25703Z	LPBC23	
175	1	AL		1	3/16" Hex	2/0 - #14	35-120 in-lbs		4	1/8" Hex	#4 - #14	35 in-lbs	4	OLD25701ZXDIN	OLCH1321Z	
175	2			1	3/16" Hex	2/0 - #14	35-120 in-lbs		4	1/8" Hex	#4 - #14	35 in-lbs	4	OLD25702ZXDIN	OLCH1322Z	
175	3			1	3/16" Hex	2/0 - #14	35-120 in-lbs		4	1/8" Hex	#4 - #14	35 in-lbs	4	OLD25703ZXDIN	OLCH1323Z	
175	Adder			1	-	2/0 - #14	35-120 in-lbs		4	-	#4 - #14	35 in-lbs	4	OLD2570AZXDIN	-	
175	1	CU		1	3/16" Hex	2/0 - #14	35-120 in-lbs		4	Slotted	#4 - #14	35 in-lbs	3	OLD29701Z	LPBC21	
175	2			1	3/16" Hex	2/0 - #14	35-120 in-lbs		4	Slotted	#4 - #14	35 in-lbs	3	OLD29702Z	LPBC22	
175	3			1	3/16" Hex	2/0 - #14	35-120 in-lbs		4	Slotted	#4 - #14	35 in-lbs	3	OLD29703Z	LPBC23	
175	1	CU		1	3/16" Hex	2/0 - #14	35-120 in-lbs		4	Slotted	#4 - #14	35 in-lbs	4	OLD29701ZXDIN	OLCH1321Z	
175	2			1	3/16" Hex	2/0 - #14	35-120 in-lbs		4	Slotted	#4 - #14	35 in-lbs	4	OLD29702ZXDIN	OLCH1322Z	
175	3			1	3/16" Hex	2/0 - #14	35-120 in-lbs		4	Slotted	#4 - #14	35 in-lbs	4	OLD29703ZXDIN	OLCH1323Z	
175	Adder			1	-	2/0 - #14	35-120 in-lbs		4	-	#4 - #14	35 in-lbs	4	OLD2970AZXDIN	-	
175	2	AL		1	5/16" Hex	2/0 - #14	35-120 in-lbs		4	Slotted	#4 - #14	35 in-lbs	1	OLD04022Z	LPBC02	
175	3			1	5/16" Hex	2/0 - #14	35-120 in-lbs		4	Slotted	#4 - #14	35 in-lbs	1	OLD04023Z	LPBC03	
175	2	AL		1	5/16" Hex	2/0 - #14	35-120 in-lbs		6	Slotted	#4 - #14	35 in-lbs	1	OLD04012Z	LPBC02	
175	3			1	3/16" Hex	2/0 - #14	40-120 in-lbs		6	1/8" Hex	#4 - #14	35 in-lbs	1	LFD04013Z	LPBC03	
175	1	AL		1	5/16" Hex	2/0 - #14	35-120 in-lbs		6	1/8" Hex	#4 - #14	35 in-lbs	4	OLD25801ZXDIN	OLCH1321Z	
175	2			1	5/16" Hex	2/0 - #14	35-120 in-lbs		6	1/8" Hex	#4 - #14	35 in-lbs	4	OLD25802ZXDIN	OLCH1322Z	
175	3			1	5/16" Hex	2/0 - #14	35-120 in-lbs		6	1/8" Hex	#4 - #14	35 in-lbs	4	OLD25803ZXDIN	OLCH1323Z	
175	Adder			1	5/16" Hex	2/0 - #14	35-120 in-lbs		6	1/8" Hex	#4 - #14	35 in-lbs	4	OLD2580AZXDIN	-	
310	3	AL		1	5/16" Hex	350kcmil - #6	40-120 in-lbs		2	3/16" Hex	2/0 - #14	35-120 in-lbs	9	OLD335543Z	OLCH1333Z	
310	2	AL		1	5/16" Hex	350kcmil - #6	275 in-lbs		6	Slotted	#4 - #14	35 in-lbs	1	OLD04042Z	LPBC02	
310	3			1	5/16" Hex	350kcmil - #6	275 in-lbs		6	Slotted	#4 - #14	35 in-lbs	1	OLD04043Z	LPBC03	
335	1	AL		1	5/16" Hex	400kcmil - #6	275 in-lbs		4	Slotted	#2 - #14	35-50 in-lbs	5	OLD35521Z	LPBC31	
335	2			1	5/16" Hex	400kcmil - #6	275 in-lbs		4	Slotted	#2 - #14	35-50 in-lbs	5	OLD35522Z	LPBC32	
380	3	AL		1	3/8" Hex	500kcmil - #6	375 in-lbs		4	5/32" Hex	#2 - #14	35-50 in-lbs	5	LFD35523Z	LPBC33	
335	1			1	5/16" Hex	400kcmil - #6	275 in-lbs			6	Slotted	#2 - #14	35-50 in-lbs	5	OLD35531Z	LPBC31
335	2			1	5/16" Hex	400kcmil - #6	275 in-lbs			6	Slotted	#2 - #14	35-50 in-lbs	5	OLD35532Z	LPBC32
380	3			1	3/8" Hex	500kcmil - #6	375 in-lbs		6	5/32" Hex	#2 - #14	40-50 in-lbs	5	LFD35533Z	LPBC33	
335	1	AL		1	Slotted	400kcmil - #6	275 in-lbs		8	Slotted	#2 - #14	35-50 in-lbs	6	OLD45601Z	LPBC41	
335	2			1	Slotted	400kcmil - #6	275 in-lbs		8	Slotted	#2 - #14	35-50 in-lbs	6	OLD45602Z	LPBC42	
335	3			1	Slotted	400kcmil - #6	275 in-lbs		8	Slotted	#2 - #14	35-50 in-lbs	6	OLD45603Z	LPBC43	
350	1	AL		2	3/16" Hex	2/0 - #14	35-120 in-lbs		6	Slotted	#4 - #14	35 in-lbs	5	OLD35551Z	LPBC31	
350	2			2	3w/16" Hex	2/0 - #14	35-120 in-lbs		6	Slotted	#4 - #14	35 in-lbs	5	OLD35552Z	LPBC32	
350	3			2	3/16" Hex	2/0 - #14	40-120 in-lbs		6	1/8" Hex	#4 - #14	35 in-lbs	5	LFD35553Z	LPBC33	
350	1	CU		2	Slotted	2/0 - #14	35-120 in-lbs		6	1/8" Hex	#4 - #14	35 in-lbs	5	OLD39551Z	LPBC31	
350	2			2	Slotted	2/0 - #14	35-120 in-lbs		6	1/8" Hex	#4 - #14	35 in-lbs	5	OLD39552Z	LPBC32	
350	3			2	Slotted	2/0 - #14	35-120 in-lbs		6	1/8" Hex	#4 - #14	35 in-lbs	5	OLD39553Z	LPBC33	
380	1	CU		1	Slotted	500kcmil - #6	375 in-lbs		6	5/32" Hex	#2 - #14	35-50 in-lbs	5	OLD39531Z	LPBC31	
380	2			1	Slotted	500kcmil - #6	375 in-lbs		6	5/32" Hex	#2 - #14	35-50 in-lbs	5	OLD39532Z	LPBC32	
380	3			1	Slotted	500kcmil - #6	375 in-lbs		6	5/32" Hex	#2 - #14	35-50 in-lbs	5	OLD39533Z	LPBC33	
380	1	AL		1	Slotted	500kcmil - #4	375 in-lbs		6	Slotted	#2 - #14	35-50 in-lbs	6	OLD45511Z	LPBC41	
380	2			1	Slotted	500kcmil - #4	375 in-lbs		6	Slotted	#2 - #14	35-50 in-lbs	6	OLD45512Z	LPBC42	
380	3			1	Slotted	500kcmil - #4	375 in-lbs		6	Slotted	#2 - #14	35-50 in-lbs	6	OLD45513Z	LPBC43	
380	1			1	3/8" Hex	500kcmil - #4	375 in-lbs			6	5/16" Hex	2/0 - #14	35-120 in-lbs	7	OLD55791Z	LPBC51
380	2	1	3/8" Hex	500kcmil - #4	375 in-lbs	6	5/16" Hex	2/0 - #14		35-120 in-lbs	7	OLD55792Z	LPBC52			
380	3	1	3/8" Hex	500kcmil - #4	375 in-lbs	6	5/16" Hex	2/0 - #14		40-120 in-lbs	7	LFD55793Z	LPBC53			

Note: AL = Aluminum / CU = Copper *Covers sold separately

POWR-BLOKS

Distribution Block Selection Guide

AMP PER POLE	POLES	CONNECTOR MATERIAL	LINE CONNECTION				LOAD CONNECTION				FIGURE	CATALOG/ ORDERING NUMBER	*PLASTIC COVER ORDERING NUMBER		
			CONNECTOR IMAGE	OPENINGS PER POLE	LUG TYPE	WIRE RANGE	TORQUE RANGE	CONNECTOR IMAGE	OPENINGS PER POLE	LUG TYPE				WIRE RANGE	TORQUE RANGE
380	1	AL		1	3/8" Hex	500kcmil - #4	375 in-lbs		8	5/32" Hex	#2 - #14	35-50 in-lbs	7	OLD55941Z	LPBC51
380	2			1	3/8" Hex	500kcmil - #4	375 in-lbs		8	5/32" Hex	#2 - #14	35-50 in-lbs	7	OLD55942Z	LPBC52
380	3			1	3/8" Hex	500kcmil - #4	375 in-lbs		8	5/32" Hex	#2 - #14	35-50 in-lbs	7	OLD55943Z	LPBC53
380	1	AL		1	Slotted	500kcmil - #4	375 in-lbs		12	Slotted	#2 - #14	35-50 in-lbs	7	OLD55521Z	LPBC51
380	2			1	Slotted	500kcmil - #4	375 in-lbs		12	Slotted	#2 - #14	35-50 in-lbs	7	OLD55522Z	LPBC52
380	3			1	3/8" Hex	500kcmil - #4	375 in-lbs		12	5/32" Hex	#2 - #14	40-50 in-lbs	7	LFD55523Z	LPBC53
420	1	AL		1	1/2" Hex	600kcmil - #2	375 in-lbs		3	3/16" Hex	1/0 - #14	35-120 in-lbs	9	OLD35881Z	OLCH1331Z
420	3			1	1/2" Hex	600kcmil - #2	375 in-lbs		3	3/16" Hex	1/0 - #14	35-120 in-lbs			
420	1	AL		1	1/2" Hex	600kcmil - #2	375 in-lbs		12	1/8" Hex	#4 - #14	35 in-lbs	9	OLD35951Z	OLCH1331Z
420	2			1	1/2" Hex	600kcmil - #2	375 in-lbs		12	1/8" Hex	#4 - #14	35 in-lbs			
510	1	AL		2	5/16" Hex	250kcmil - #6	275 in-lbs		12	1/8" Hex	#4 - #14	35 in-lbs	9	OLD35961Z	OLCH1331Z
510	2			2	5/16" Hex	250kcmil - #6	275 in-lbs		12	1/8" Hex	#4 - #14	35 in-lbs			
510	3			2	5/16" Hex	250kcmil - #6	275 in-lbs		12	1/8" Hex	#4 - #14	35 in-lbs			
760	1	AL		2	3/8" Hex	500kcmil - #6	375 in-lbs		8	5/16" Hex	2/0 - #14	35-120 in-lbs	7	OLD55861Z	LPBC51
760	2			2	3/8" Hex	500kcmil - #6	375 in-lbs		8	5/16" Hex	2/0 - #14	35-120 in-lbs			
760	3			2	3/8" Hex	500kcmil - #4	375 in-lbs		8	3/16" Hex	2/0 - #14	40-120 in-lbs			
760	1	CU		2	3/8" Hex	500kcmil - #4	375 in-lbs		8	3/16" Hex	2/0 - #14	35-120 in-lbs	7	OLD59861Z	LPBC51
760	2			2	3/8" Hex	500kcmil - #4	375 in-lbs		8	3/16" Hex	2/0 - #14	35-120 in-lbs			
760	3			2	3/8" Hex	500kcmil - #4	375 in-lbs		8	3/16" Hex	2/0 - #14	35-120 in-lbs			
760	1	AL		2	3/8" Hex	500kcmil - #6	375 in-lbs		12	Slotted	#4 - #14	35 in-lbs	7	OLD55921Z	LPBC51
760	2			2	3/8" Hex	500kcmil - #6	375 in-lbs		12	Slotted	#4 - #14	35 in-lbs			
760	3			2	3/8" Hex	500kcmil - #4	375 in-lbs		12	1/8" Hex	#4 - #14	35 in-lbs			
760	1	CU		2	3/8" Hex	500kcmil - #6	375 in-lbs		12	Slotted	#2 - #14	35-50 in-lbs	7	OLD59921Z	LPBC51
760	2			2	3/8" Hex	500kcmil - #6	375 in-lbs		12	Slotted	#2 - #14	35-50 in-lbs			
760	3			2	3/8" Hex	500kcmil - #6	375 in-lbs		12	Slotted	#2 - #14	35-50 in-lbs			
760	3	AL		2	1/2" Hex	500kcmil - #4	375 in-lbs		12	5/16" Hex	#2 - #14	35-50 in-lbs	7	OLD54083Z	LPBC53
840	3	AL		2	1/2" Hex	600kcmil - #2	375 in-lbs		4	5/16" Hex	3/0 - #6	120 in-lbs	7	OLD54113Z	LPBC53
									4	5/16" Hex	#4 - #14	35 in-lbs			
950	1	AL		2	9/16" Hex	750kcmil - 1/0	600 in-lbs		10	3/16" Hex	2/0 - #14	50-120 in-lbs	8	OLD57041Z	OLCH1351Z
950	3	AL		2	9/16" Hex	750kcmil - 1/0	600 in-lbs		10	3/16" Hex	2/0 - #14	50-120 in-lbs	8	OLD57043Z	OLCH1351Z
950	1	AL		2	9/16" Hex	750kcmil - 1/0	600 in-lbs		3	5/16" Hex	250kcmil - #6	275 in-lbs	8	OLD57051Z	OLCH1351Z
									12	5/32" Hex	#2 - #14	40-50 in-lbs			
950	3	AL		2	9/16" Hex	750kcmil - 1/0	600 in-lbs		3	5/16" Hex	250kcmil - #6	275 in-lbs	8	OLD57053Z	OLCH1351Z
950	1	AL		2	9/16" Hex	750kcmil - 1/0	600 in-lbs		4	1/4" Hex	3/0 - #6	180 in-lbs	8	OLD57071Z	OLCH1351Z
									12	5/32" Hex	#2 - #14	40-50 in-lbs			
950	3	AL		2	9/16" Hex	750kcmil - 1/0	600 in-lbs		4	1/4" Hex	3/0 - #6	180 in-lbs	8	OLD57073Z	OLCH1351Z
									12	5/32" Hex	#2 - #14	40-50 in-lbs			

Note: AL = Aluminum / CU = Copper
*Covers sold separately

POWR-BLOKS

Splicer Block Selection Guide

AMP PER POLE	POLES	CONNECTOR MATERIAL	LINE CONNECTION				LOAD CONNECTION				FIGURE	CATALOG/ ORDERING NUMBER	*PLASTIC COVER ORDERING NUMBER		
			CONNECTOR IMAGE	OPENINGS PER POLE	LUG TYPE	WIRE RANGE	TORQUE RANGE	CONNECTOR IMAGE	OPENINGS PER POLE	LUG TYPE				WIRE RANGE	TORQUE RANGE
115	1	AL		1	Slotted	#2 - #14	35-50 in-lbs		1	Slotted	#2 - #14	35-50 in-lbs	10	OLS13301Z	LPBC1441
115	2			1	Slotted	#2 - #14	35-50 in-lbs		1	Slotted	#2 - #14	35-50 in-lbs	10	OLS13302Z	LPBC1442
115	3			1	5/32" Hex	#2 - #14	40-50 in-lbs		1	5/32" Hex	#2 - #14	40-50 in-lbs	2	LFS13003Z	-
115	4			1	Slotted	#2 - #14	35-50 in-lbs		1	Slotted	#2 - #14	35-50 in-lbs	10	OLS13304Z	LPBC1444
115	1	AL		1	Slotted	#2 - #14	35-50 in-lbs		1	Slotted	#2 - #14	35-50 in-lbs	3	OLS25521Z	LPBC21
115	2			1	Slotted	#2 - #14	35-50 in-lbs		1	Slotted	#2 - #14	35-50 in-lbs	3	OLS25522Z	LPBC22
115	3			1	Slotted	#2 - #14	35-50 in-lbs		1	Slotted	#2 - #14	35-50 in-lbs	3	OLS25523Z	LPBC23
150	1	CU		1	3/16" Hex	1/0 - #14	35-120 in-lbs		1	3/16" Hex	1/0 - #14	35-120 in-lbs	3	OLS21211Z	LPBC21
150	2			1	3/16" Hex	1/0 - #14	35-120 in-lbs		1	3/16" Hex	1/0 - #14	35-120 in-lbs	3	OLS21212Z	LPBC22
150	3			1	3/16" Hex	1/0 - #14	35-120 in-lbs		1	3/16" Hex	1/0 - #14	35-120 in-lbs	3	OLS21213Z	LPBC23
175	1	AL		1	5/16" Hex	2/0 - #14	35-120 in-lbs		1	5/16" Hex	2/0 - #14	35-120 in-lbs	3	OLS25721Z	LPBC21
175	2			1	5/16" Hex	2/0 - #14	35-120 in-lbs		1	5/16" Hex	2/0 - #14	35-120 in-lbs	3	OLS25722Z	LPBC22
175	3			1	3/16" Hex	2/0 - #14	40-120 in-lbs		1	3/16" Hex	2/0 - #14	40-120 in-lbs	3	LFS25723Z	LPBC23
175	1	AL		1	5/16" Hex	2/0 - #14	35-120 in-lbs		1	5/16" Hex	2/0 - #14	35-120 in-lbs	4	OLS25721ZXDIN	OLCH1321Z
175	2			1	5/16" Hex	2/0 - #14	35-120 in-lbs		1	5/16" Hex	2/0 - #14	35-120 in-lbs	4	OLS25722ZXDIN	OLCH1322Z
175	3			1	5/16" Hex	2/0 - #14	35-120 in-lbs		1	5/16" Hex	2/0 - #14	35-120 in-lbs	4	OLS25723ZXDIN	OLCH1323Z
175	Adder			1	-	2/0 - #14	35-120 in-lbs		1	-	2/0 - #14	35-120 in-lbs	4	OLS2572AZXDIN	-
175	1	CU		1	5/16" Hex	2/0 - #14	35-120 in-lbs		1	5/16" Hex	2/0 - #14	35-120 in-lbs	4	OLS29721ZXDIN	OLCH1321Z
175	2			1	5/16" Hex	2/0 - #14	35-120 in-lbs		1	5/16" Hex	2/0 - #14	35-120 in-lbs	4	OLS29722ZXDIN	OLCH1322Z
175	3			1	5/16" Hex	2/0 - #14	35-120 in-lbs		1	5/16" Hex	2/0 - #14	35-120 in-lbs	4	OLS29723ZXDIN	OLCH1323Z
175	Adder			1	-	2/0 - #14	35-120 in-lbs		1	-	2/0 - #14	35-120 in-lbs	4	OLS2972AZXDIN	-
255	1	AL		1	5/16" Hex	250kcmil - #6	275 in-lbs		1	5/16" Hex	250kcmil - #6	275 in-lbs	5	OLS31231Z	LPBC31
255	2			1	5/16" Hex	250kcmil - #6	275 in-lbs		1	5/16" Hex	250kcmil - #6	275 in-lbs	5	OLS31232Z	LPBC32
255	3			1	5/16" Hex	250kcmil - #6	275 in-lbs		1	5/16" Hex	250kcmil - #6	275 in-lbs	5	OLS31233Z	LPBC33
255	1	CU		1	3/8" Hex	250kcmil - #6	375 in-lbs		1	3/8" Hex	250kcmil - #6	375 in-lbs	5	OLS31241Z	LPBC31
255	2			1	3/8" Hex	250kcmil - #6	375 in-lbs		1	3/8" Hex	250kcmil - #6	375 in-lbs	5	OLS31242Z	LPBC32
255	3			1	3/8" Hex	250kcmil - #6	375 in-lbs		1	3/8" Hex	250kcmil - #6	375 in-lbs	5	OLS31243Z	LPBC33
310	2	AL		1	5/16" Hex	350kcmil - #6	275 in-lbs		1	5/16" Hex	350kcmil - #6	275 in-lbs	1	OLS03032Z	LPBC02
310	3			1	5/16" Hex	350kcmil - #6	275 in-lbs		1	5/16" Hex	350kcmil - #6	275 in-lbs	1	OLS03033Z	LPBC03
310	1	AL		1	5/16" Hex	350kcmil - #6	275 in-lbs		1	5/16" Hex	350kcmil - #6	275 in-lbs	5	OLS31261Z	LPBC31
310	2			1	5/16" Hex	350kcmil - #6	275 in-lbs		1	5/16" Hex	350kcmil - #6	275 in-lbs	5	OLS31262Z	LPBC32
310	3			1	5/16" Hex	350kcmil - #6	275 in-lbs		1	5/16" Hex	350kcmil - #6	275 in-lbs	5	OLS31263Z	LPBC33
350	3	AL		2	5/16" Hex	2/0 - #14	35-120 in-lbs		2	5/16" Hex	2/0 - #14	35-120 in-lbs	9	OLS33053Z	OLCH1333Z
420	1	AL		1	1/2" Hex	600kcmil - #4	500 in-lbs		1	1/2" Hex	600kcmil - #4	500 in-lbs	6	OLS45571Z	LPBC41
420	2			1	1/2" Hex	600kcmil - #4	500 in-lbs		1	1/2" Hex	600kcmil - #4	500 in-lbs	6	OLS45572Z	LPBC42
420	3			1	1/2" Hex	600kcmil - #4	500 in-lbs		1	1/2" Hex	600kcmil - #4	500 in-lbs	6	OLS45573Z	LPBC43
510	3	AL		2	5/16" Hex	250kcmil - #6	275 in-lbs		2	5/16" Hex	250kcmil - #6	275 in-lbs	9	OLS33203Z	OLCH1333Z
620	1	AL		2	5/16" Hex	350kcmil - #4	275 in-lbs		2	5/16" Hex	350kcmil - #4	275 in-lbs	7	OLS51291Z	LPBC51
620	2			2	5/16" Hex	350kcmil - #4	275 in-lbs		2	5/16" Hex	350kcmil - #4	275 in-lbs	7	OLS51292Z	LPBC52
620	3			2	5/16" Hex	350kcmil - #4	275 in-lbs		2	5/16" Hex	350kcmil - #4	275 in-lbs	7	OLS51293Z	LPBC53
760	1	AL		2	3/8" Hex	500kcmil - #4	375 in-lbs		2	3/8" Hex	500kcmil - #4	375 in-lbs	7	OLS53011Z	LPBC51
760	2			2	3/8" Hex	500kcmil - #4	375 in-lbs		2	3/8" Hex	500kcmil - #4	375 in-lbs	7	OLS53012Z	LPBC52
760	3			2	3/8" Hex	500kcmil - #4	375 in-lbs		2	3/8" Hex	500kcmil - #4	375 in-lbs	7	OLS53013Z	LPBC53

Note: AL = Aluminum / CU = Copper
Note: *Covers sold separately

POWR-BLOKS

Distribution Block and Splicer Block Outline Drawings

Dimensions Inches (mm)

Figure 1

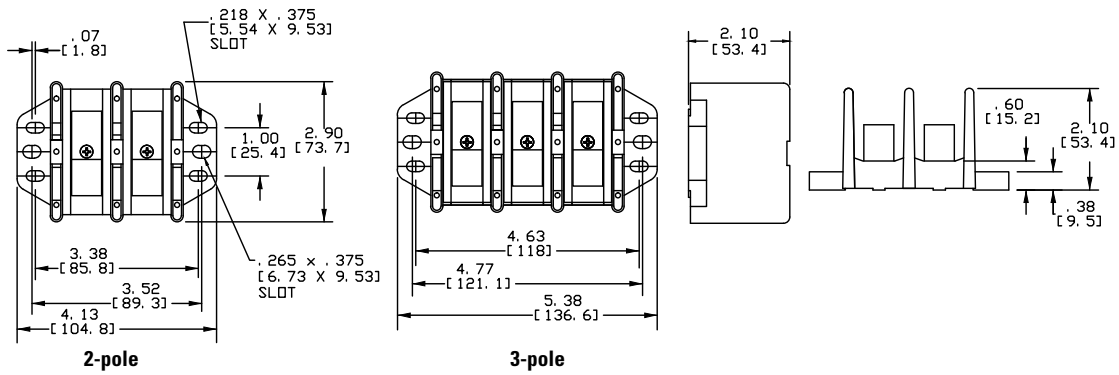

Figure 2

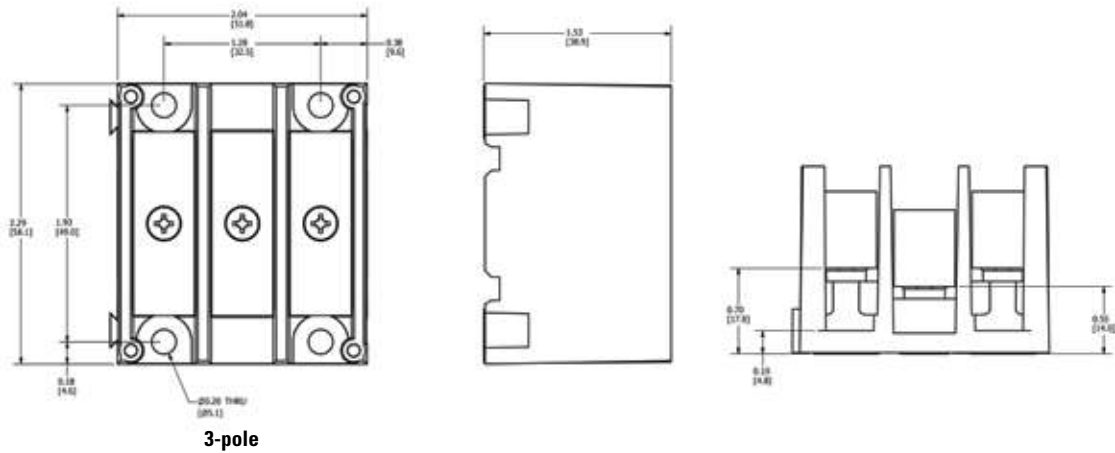
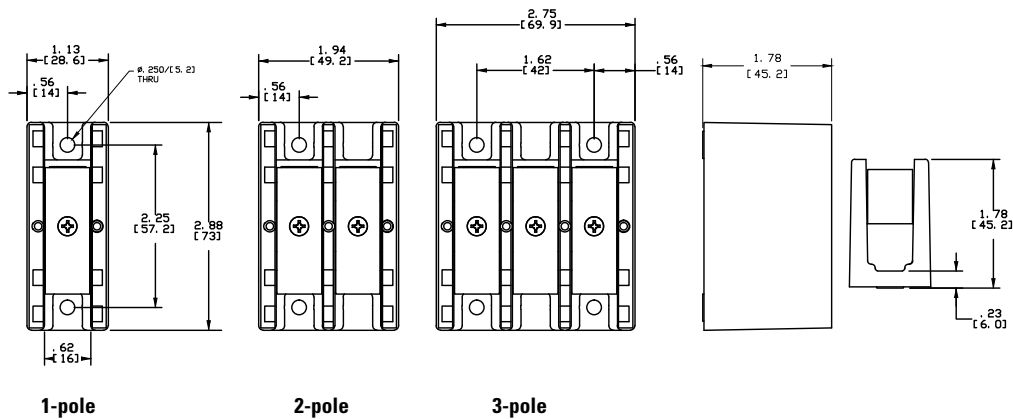

Figure 3



POWR-BLOKS

Distribution Block and Splicer Block Outline Drawings

Dimensions Inches (mm)

Figure 4

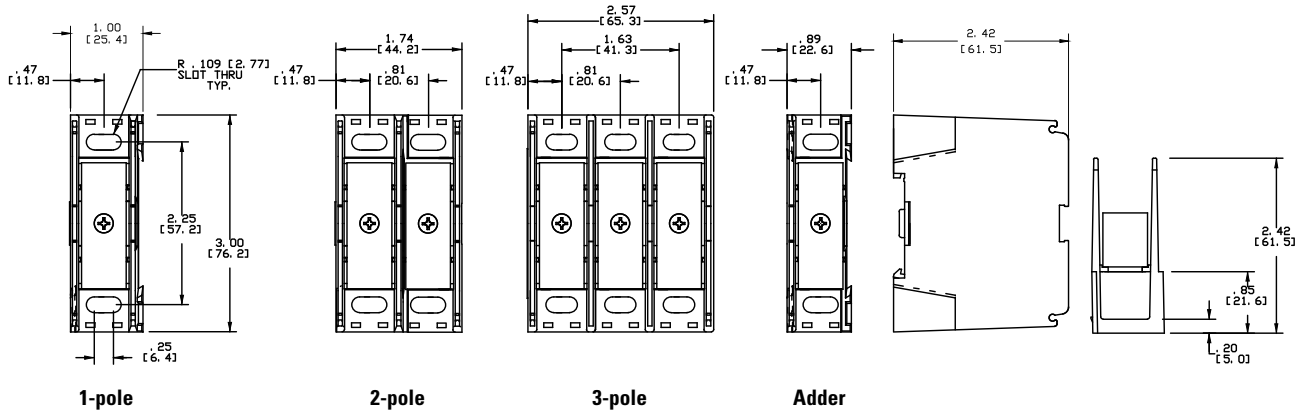

Figure 5

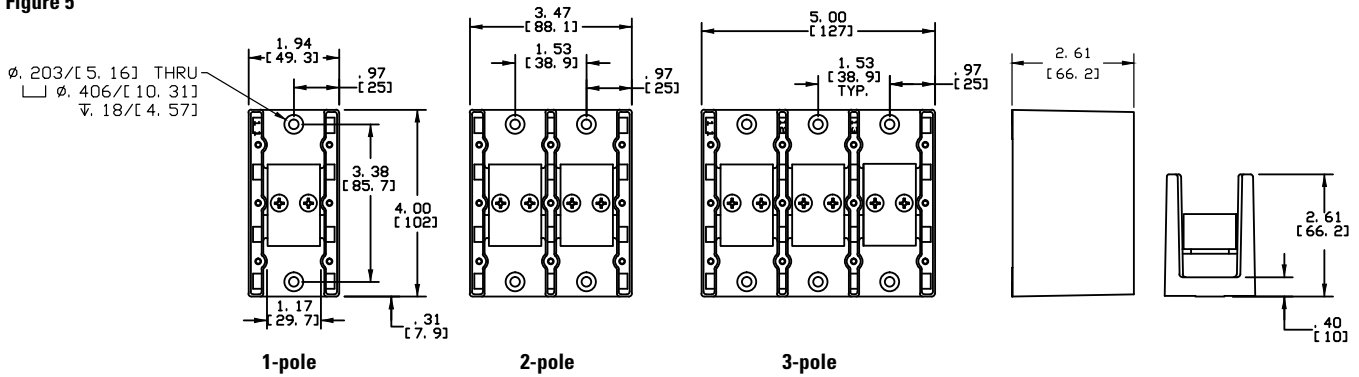
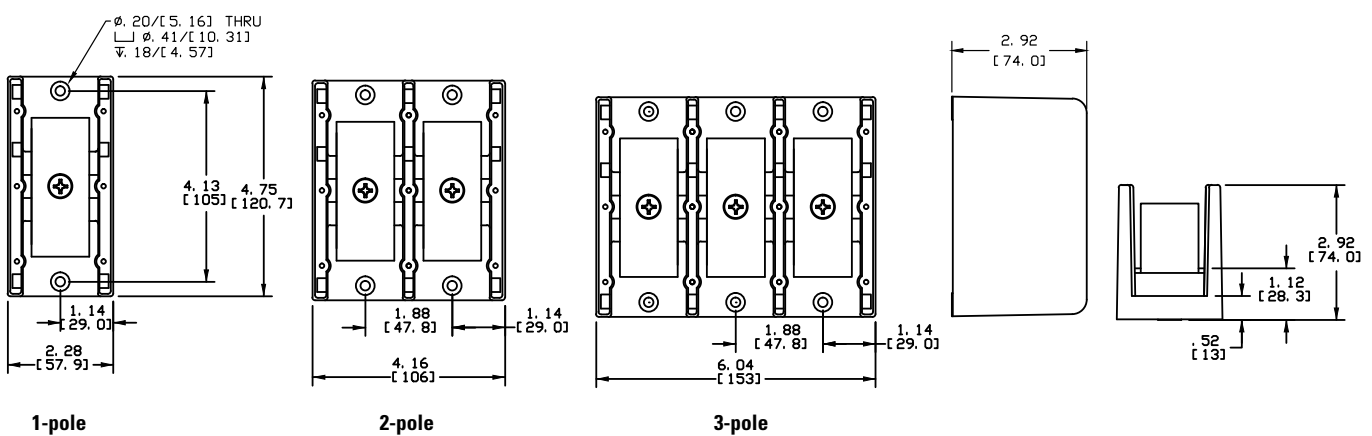

Figure 6



POWR-BLOKS

Distribution Block and Splicer Block Outline Drawings Dimensions Inches (mm)

Figure 7

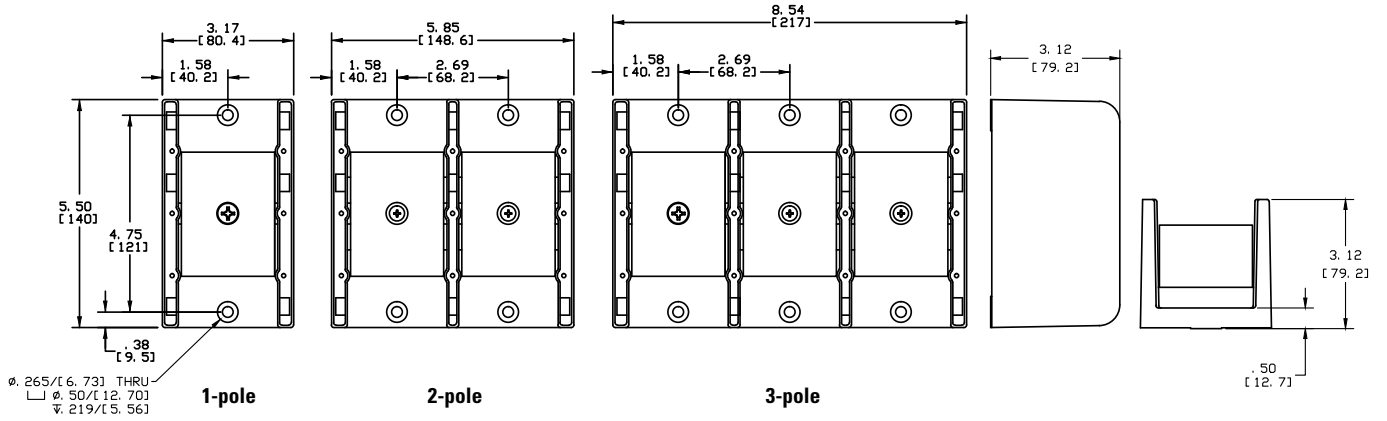

Figure 8

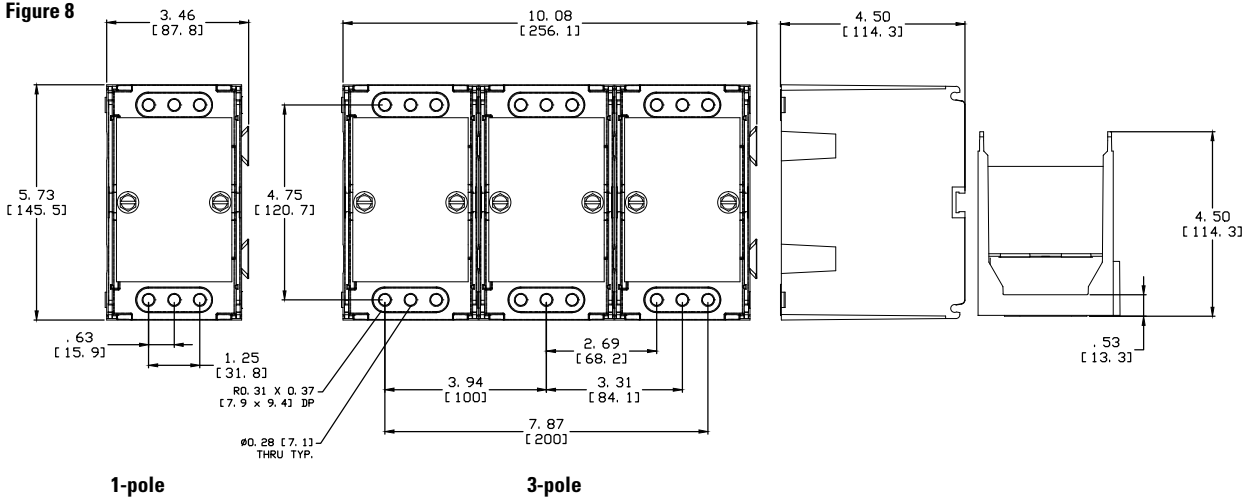
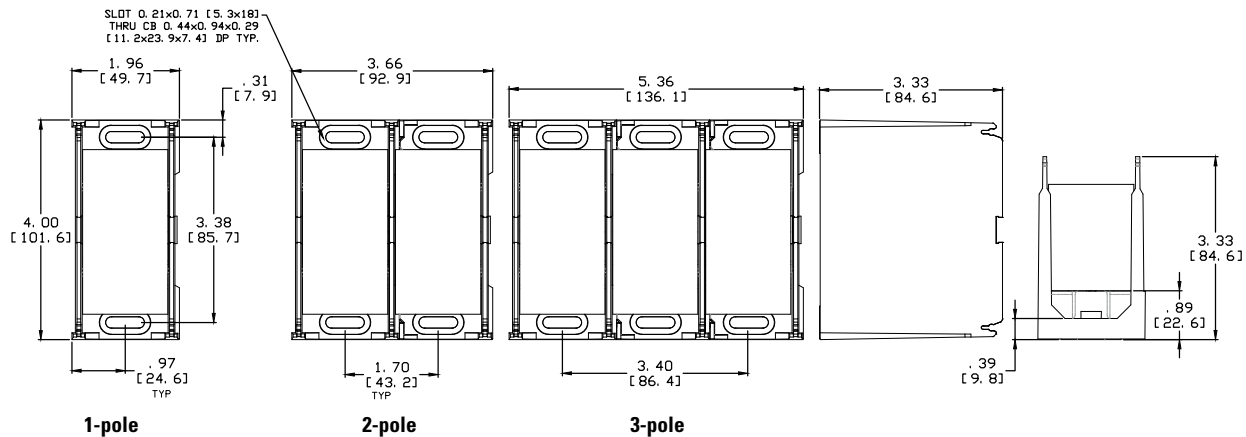

Figure 9



POWR-BLOKS

Distribution Block and Splicer Block Outline Drawings Dimensions Inches (mm)

Figure 10

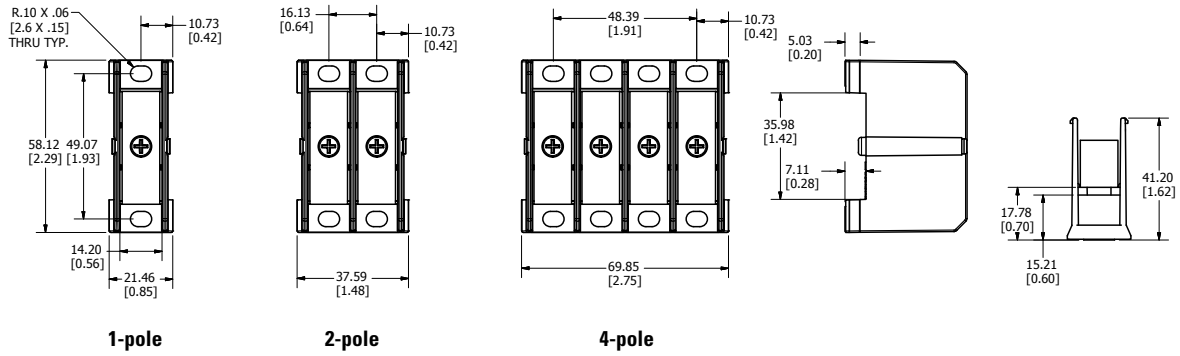

GDB SERIES TOUCH-SAFE POWR-BLOKS

Global Distribution Blocks



Features/Benefits

- Global part meeting UL standards
- Space saving design
- Integrated touch-safe cover to increase safety
- IP20 protection rating
- Mounts to DIN rail or panels
- Reliable brass connections for excellent continuity in a smaller design

Specifications

Voltage Rating	UL: 600 VAC/VDC
Ampere Rating	80 – 335 A
Material	Thermoplastic
Connector	GDBxxxx: Brass GDBAxxxx: Aluminum (Tin Plated)
Flammability Rating	UL94 V-0
Approvals	UL Recognized (File: E309688, E171395) UL Listed (File: E482231) CSA Certified (File: 700111)
Operating Temperature	-40°C to +90°C
Storage Temperature	-40°C to +100°C
Relative Humidity	50% @ 40°C, 90% @ 20°C
Environmental	RoHS compliant

Description

POWR-BLOKS Global Distribution Blocks add safety and mounting versatility to our distribution block solutions. The Global Distribution Blocks are approved to UL standards. The Global Distribution Blocks are IP20 finger safe to reduce the risk of contact and eliminate the need for block or panel covers. Installation is quick and easy, all blocks can be mounted on DIN rail or to the panel.

Electrical Specifications

Web Resources

For additional information visit Littelfuse.com/gdb

CATALOG/ ORDERING NUMBER	POLES	AMPS	WIRE RANGE				OVERCURRENT PROTECTION FUZE REQUIRED						SCCR IN RMS SYM AMPS	AGENCY APPROVALS			
			LINE CONNECTION		LOAD CONNECTION		CLASS J (JTD_ID)	Class T (JLLN, JLLS)	Class RK1 (LLNRK, LLSRK, KLNLR, KLSLR)	Class RK5 (FLNR, FLRS, IDSR)	CLASS G (SLC)	CLASS CC (CCMR, KLDLR, KLKR)		UR	cURus	UL	CSA
			LINE	OPENINGS PER POLE	OPENINGS PER POLE	LOAD											
GDB60801Z	1	80	1	#8 - #4	6	#8 - #4 #10 - #14	80	-	-	-	-	-	100,000		•		
GDB61151Z	1	115	1	#8 - #2 #10 - #6	6	#14 - #4	125	-	-	-	-	-	100,000		•		
GDB61153Z	3	115	1	#8 - #2	6	#14 - #4	125	-	-	-	-	-	100,000		•		
GDBAD211Z	1	115	1	#14 - #2	1	#14 - #2	175	225	100	60	60	30	100,000			•	•
GDBAD241Z	1	115	1	#10 - #2	4	#14 - #10	125	200	100	30	60	30	65,000			•	•
GDB61601Z	1	160	1	#8 - 2/0	6	#14 - #4	175	-	-	-	-	-	100,000	•			
GDB61753Z	3	175	1	#8 - 2/0	6	#14 - #4	175	-	-	-	-	-	100,000		•		
GDBAD421Z	1	200	1	#8 - 3/0	1	#8 - 3/0	225	225	200	60	60	30	100,000			•	•
GDBAP421Z	1	200	1	#8 - 3/0	1	#8 - 3/0	225	225	200	60	60	30	100,000			•	•
GDBAD451Z	1	200	1	#8 - 3/0 #8 - 3/0	4	#8 - #2	225	225	200	60	60	30	100,000			•	•
						#14 - #8	100	110	100	30	60						
GDBAP451Z	1	200	1	#8 - 3/0 #8 - 3/0	4	#8 - #2	225	225	200	60	60	30	100,000			•	•
						#14 - #8	100	110	100	30	60						
GDB63101Z	1	310	1	3/0 - 350 kcmil	11	#14 - #2 #14 - #6 #14 - #8	350	-	-	-	-	-	100,000	•			
GDBAD741Z	1	335	1	#6 - 400 kcmil #14 - 3/0	8	#14 - #2	-	-	-	-	-	-	10,000	•			•

GDB SERIES TOUCH-SAFE POWR-BLOKS

Global Distribution Blocks

Mechanical Specification

CATALOG/ ORDERING NUMBER	POLES	AMP RATING PER POLE (UL)	LINE CONNECTION					LOAD CONNECTION				
			OPENINGS PER POLE	OPENING DIAMETER	SCREW TYPE	WIRE RANGE	TORQUE LB-IN (NM)	OPENINGS PER POLE	OPENING DIAMETER	SCREW TYPE	WIRE RANGE	TORQUE LB-IN (NM)
GDB60801Z	1	80	1	0.28 in (7.0 mm)	Slotted	#8 - #4 (Cu)	13.5 (1.5)	6	2x 0.28 in (2x 7.0 mm)	Slotted	#8 - #4 (Cu)	13.5 (1.5)
									4x 0.18 in (4x 4.5 mm)		#10 - #14 (Cu)	7.2 (0.8)
GDB61151Z	1	115	2	0.39 in (10.0 mm)	Hex 4 mm	#8 - #2 (Cu)	31 (3.5)	6	0.28 in (7.0 mm)	Slotted	#14 - #4 (Cu)	17.5 (2)
						#10 - #6 (Cu)						
GDB61153Z	3	115	1	0.39 in (10.0 mm)	Hex 4mm	#8 - #2 (Cu)	31 (3.5)	6	0.25 in (6.5 mm)	Hex 3mm	#14 - #4 (Cu)	17.5 (2)
GDBAD211Z	1	115	1	0.323 in (8.2 mm)	Hex 4 mm	#14 - #2 (Cu/Al)	35 (4.0) #14 - #10 40 (4.5) #8 45 (5.1) #6 - #4 50 (5.6) #3 - #2	1	0.323 in (8.2 mm)	Hex 4 mm	#14 - #2 (Cu/Al)	35 (4.0) #14 - #10 40 (4.5) #8 45 (5.1) #6 - #4 50 (5.6) #3 - #2
GDBAD241Z	1	115	1	0.312 in (7.9 mm)	Hex 4 mm	#14 - #2 (Cu/Al)	35 (4.0) #14 - #10 40 (4.5) #8 45 (5.1) #6 - #4 50 (5.6) #3 - #2	4	0.159 in (4.0 mm)	Hex 2 mm	#14 - #10 (Cu/Al)	7 (0.8)
GDB61601Z	1	160	1	0.49 in (12.5 mm)	Hex 5mm	#8 - 2/0 (Cu)	35.5 (4)	6	0.28 in (7.0 mm)	Slotted	#14 - #4 (Cu)	17.5 (2.0)
GDB61753Z	3	175	1	0.47 in (12.0 mm)	Hex 5mm	#8 - 2/0 (Cu)	35.5 (4)	6	0.25 in (6.5 mm)	Hex 3mm	#14 - #4 (Cu)	17.5 (2.0)
GDBAD421Z	1	200	1	0.531 in (13.5 mm)	Hex 6mm	#14 - 3/0 (Cu/Al)	50 (5.6) #14 - #10 180 (20.3) #8 - 3/0	1	0.531 in (13.5 mm)	Hex 6mm	#14 - 3/0 (Cu/Al)	50 (5.6) #14 - #10 180 (20.3) #8 - 3/0
GDBAP421Z	1	200	1	0.531 in (13.5 mm)	Hex 6mm	#14 - 3/0 (Cu/Al)	50 (5.6) #14 - #10 180 (20.3) #8 - 3/0	1	0.531 in (13.5 mm)	Hex 6mm	#14 - 3/0 (Cu/Al)	50 (5.6) #14 - #10 180 (20.3) #8 - 3/0
GDBAD451Z	1	200	1	0.531 in (13.5 mm)	Hex 6mm	#14 - 3/0 (Cu/Al)	50 (5.6) #14 - #10 180 (20.3) #8 - 3/0	4	0.313 in (7.9mm)	Hex 5mm	#14 - #2 (Cu/Al)	40 (4.5) #14 - #10 50 (5.6) #8 - #2
GDBAP451Z	1	200	1	0.531 in (13.5 mm)	Hex 6mm	#14 - 3/0 (Cu/Al)	50 (5.6) #14 - #10 180 (20.3) #8 - 3/0	4	0.313 in (7.9mm)	Hex 5mm	#14 - #2 (Cu/Al)	40 (4.5) #14 - #10 50 (5.6) #8 - #2
GDB63101Z	1	310	1	0.75 in (19.0 mm)	Hex 8mm	3/0 - 350 kcmil (Cu)	230 (26.0)	11	2x 0.35 in (2x 9.0mm)	Slotted	#14 - #2 (Cu)	31 (3.5)
									5x 0.25 in (5x 6.5mm)		#14 - #6 (Cu)	18 (2.0)
									4x 0.21 in (4x 5.3mm)		#14 - #8 (Cu)	
GDBAD741Z	1	335	1	0.516 in (13.1 mm)	Hex 8mm & 6mm	#14 - 400 kcmil (Cu/Al)	40 (4.5) #14 - #8 80 (9.0) #6 - #2	8	0.375 in (9.5 mm)	Hex 5mm	#14 - #2 (Cu/Al)	40 (4.5) #14 - #8
							120 (13.6) #1 - #3/0 275 (31.1) #6 - #1/0 375 (42.4) 2/0 - 400 kcmil					80 (9.0) #6 - #2

GDB SERIES TOUCH-SAFE POWR-BLOKS

Global Distribution Blocks

Dimensions Inches (mm)

GDB60801Z

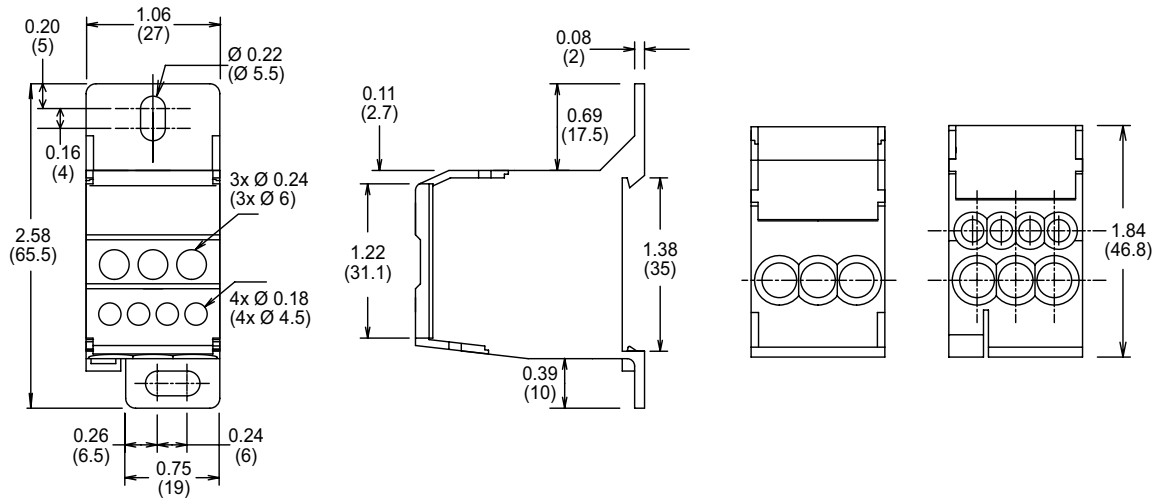

GDB61151Z

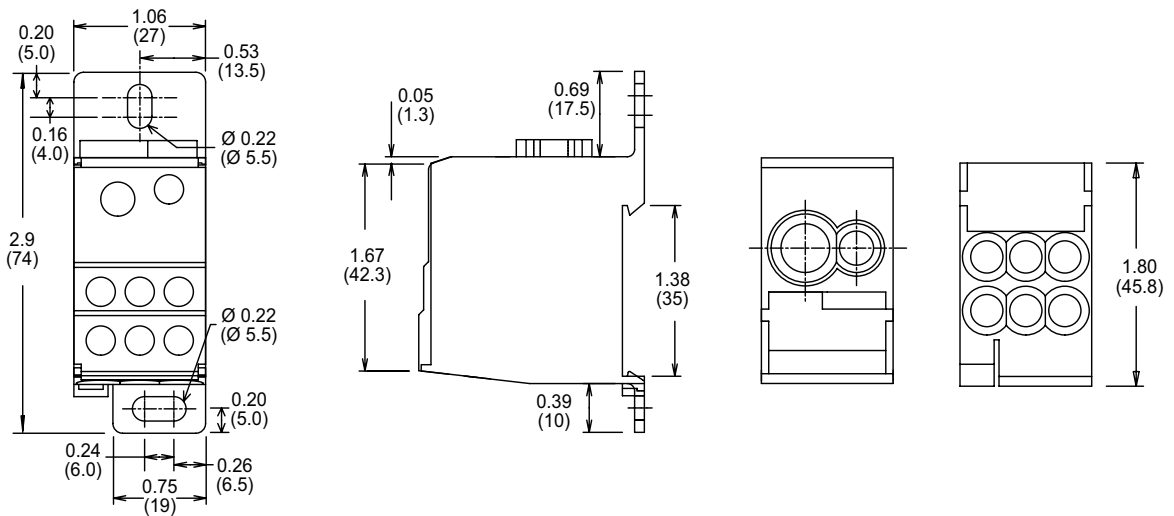

GDB61601Z

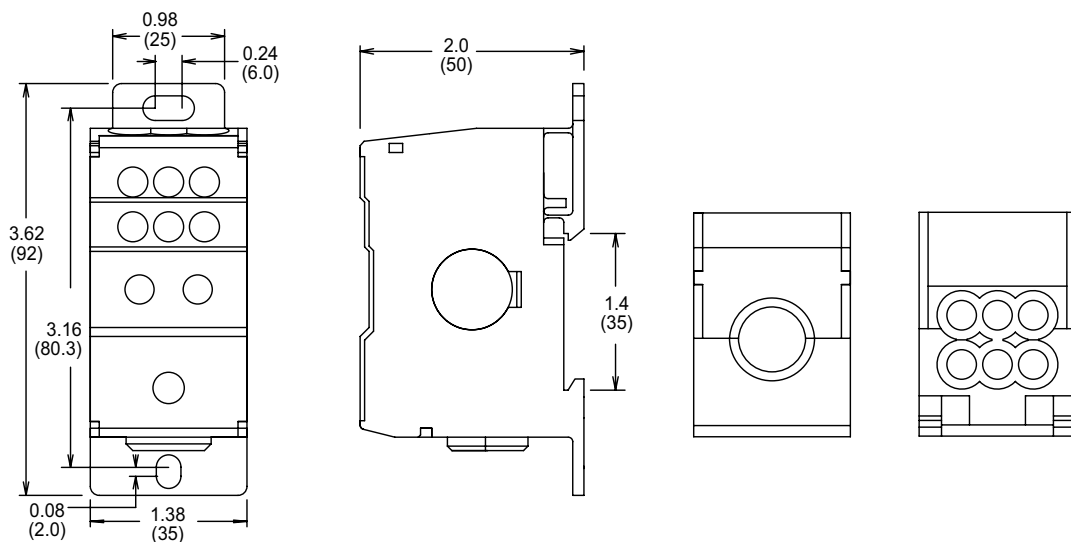

GDB SERIES TOUCH-SAFE POWR-BLOKS

Global Distribution Blocks

Dimensions Inches (mm)

GDB61153Z
GDB61753Z

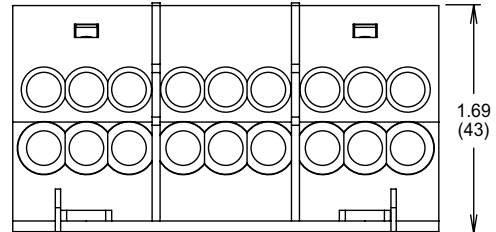
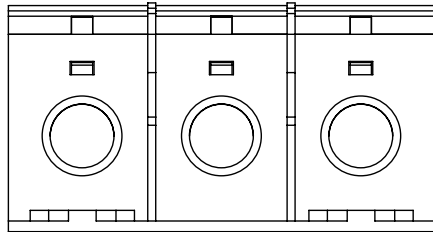
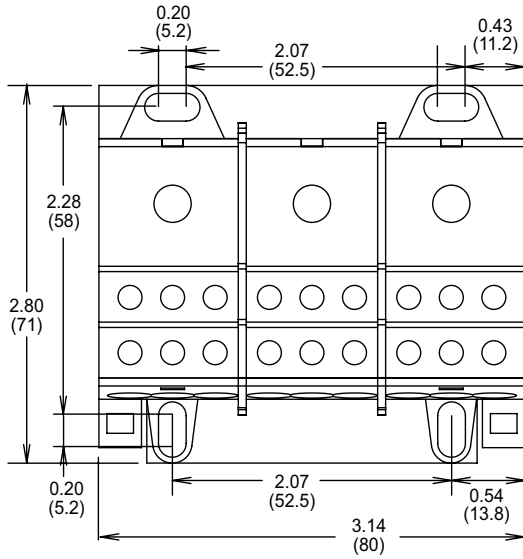

GDB63101Z

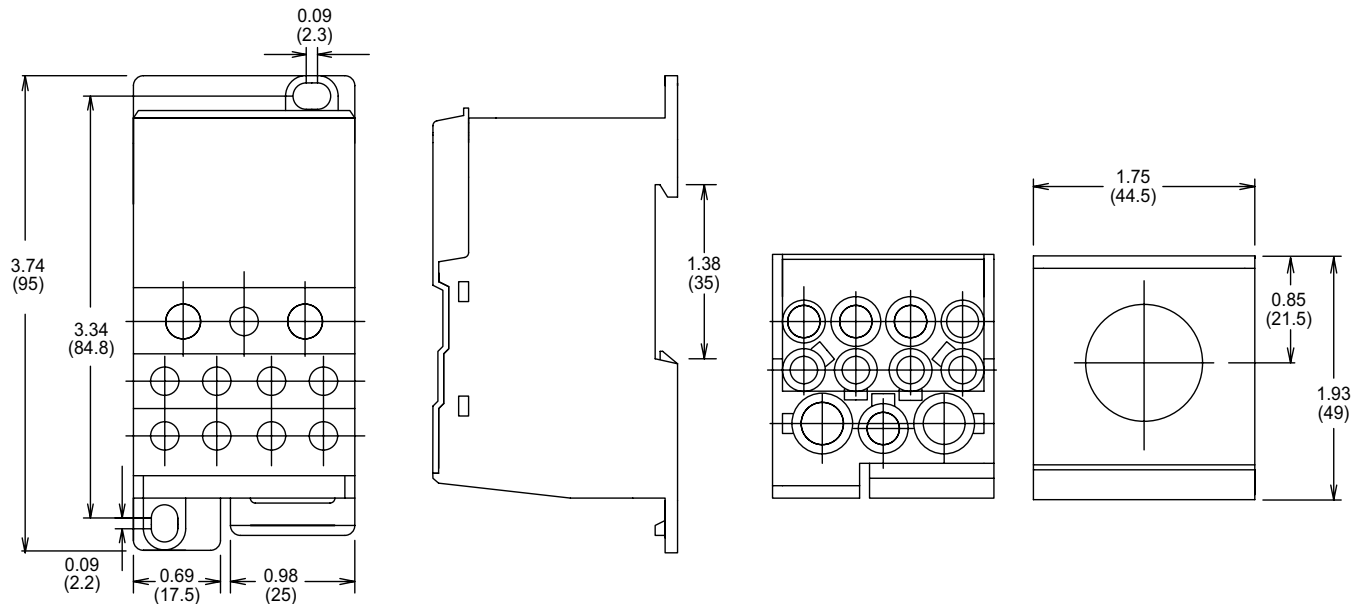

GDB SERIES TOUCH-SAFE POWR-BLOKS

Global Distribution Blocks

Dimensions Millimeters (in)

GDBAD211Z

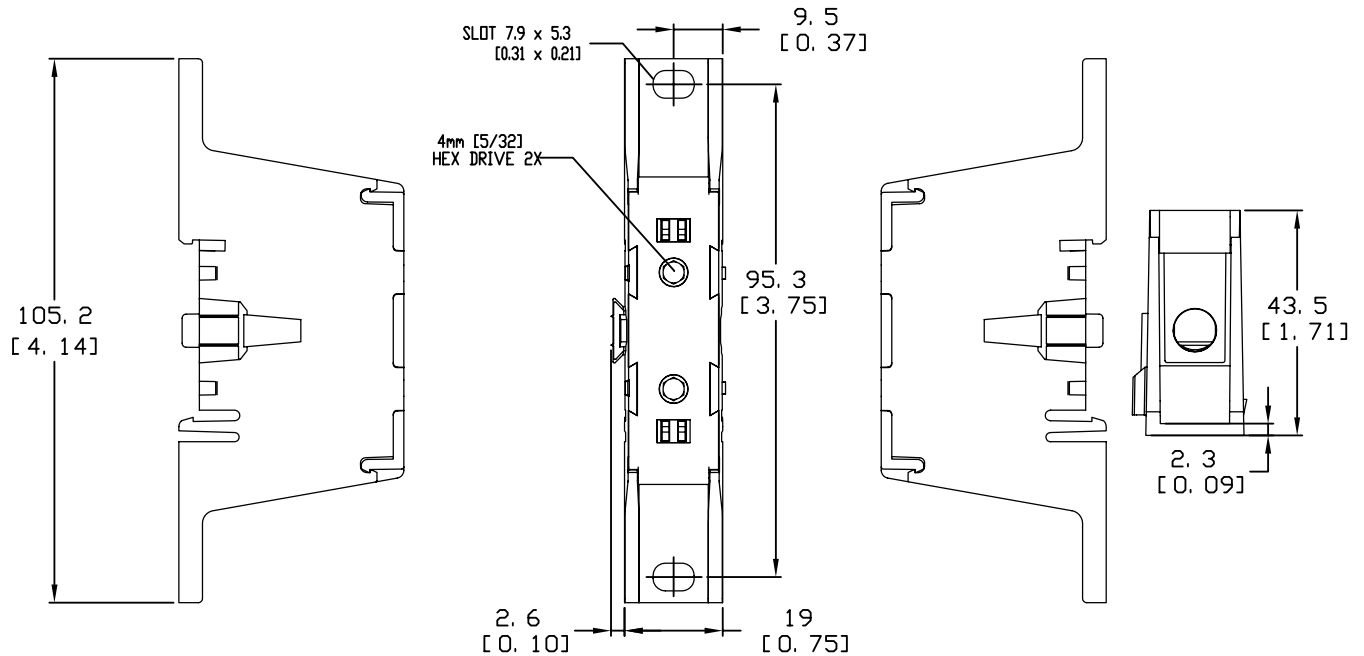

GDBAD241Z

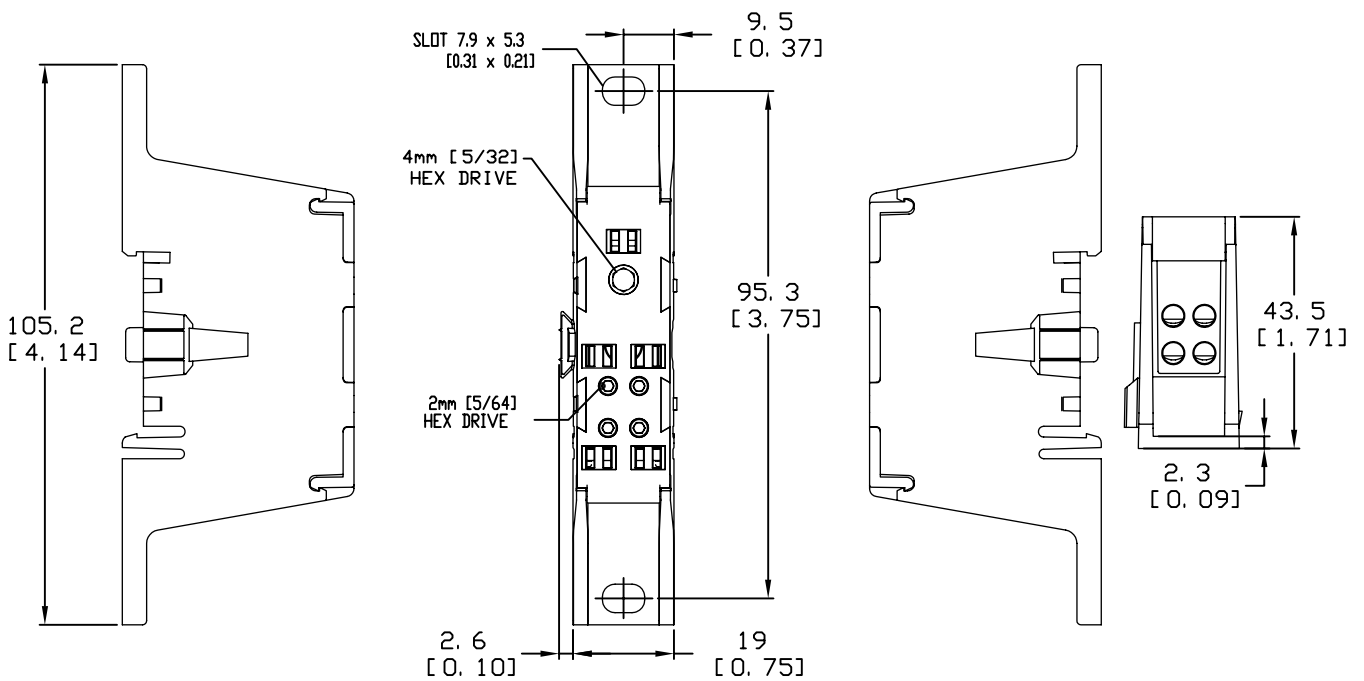

GDB SERIES TOUCH-SAFE POWR-BLOKS

Global Distribution Blocks

Dimensions Millimeters (in)

GDBAD421Z

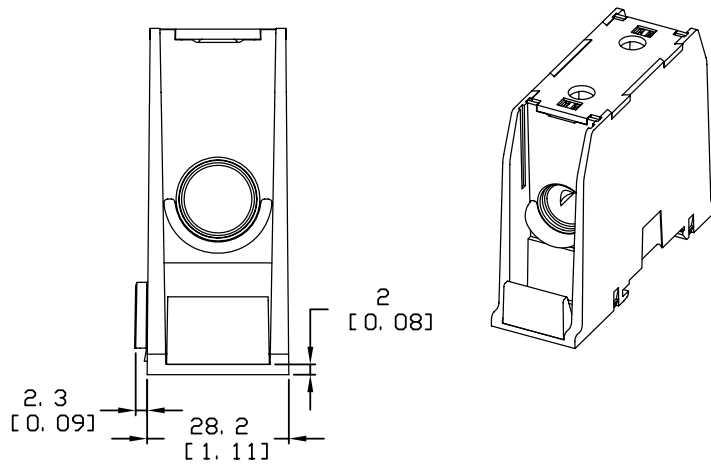
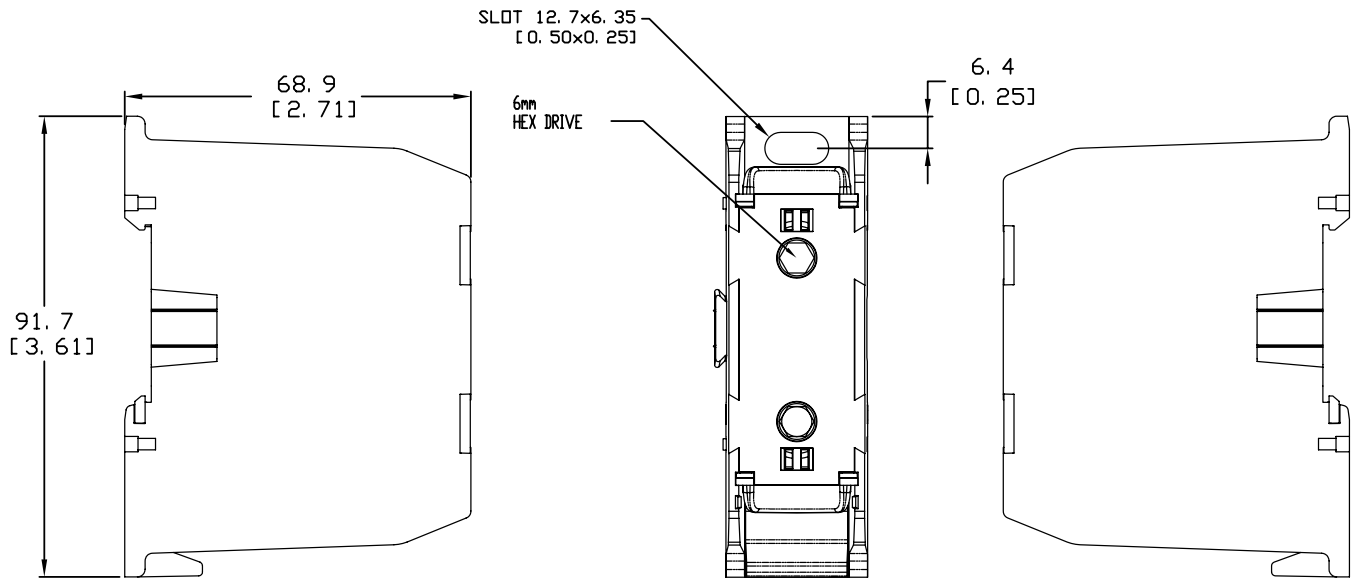

GDB SERIES TOUCH-SAFE POWR-BLOKS

Global Distribution Blocks

Dimensions Millimeters (in)

GDBAP421Z

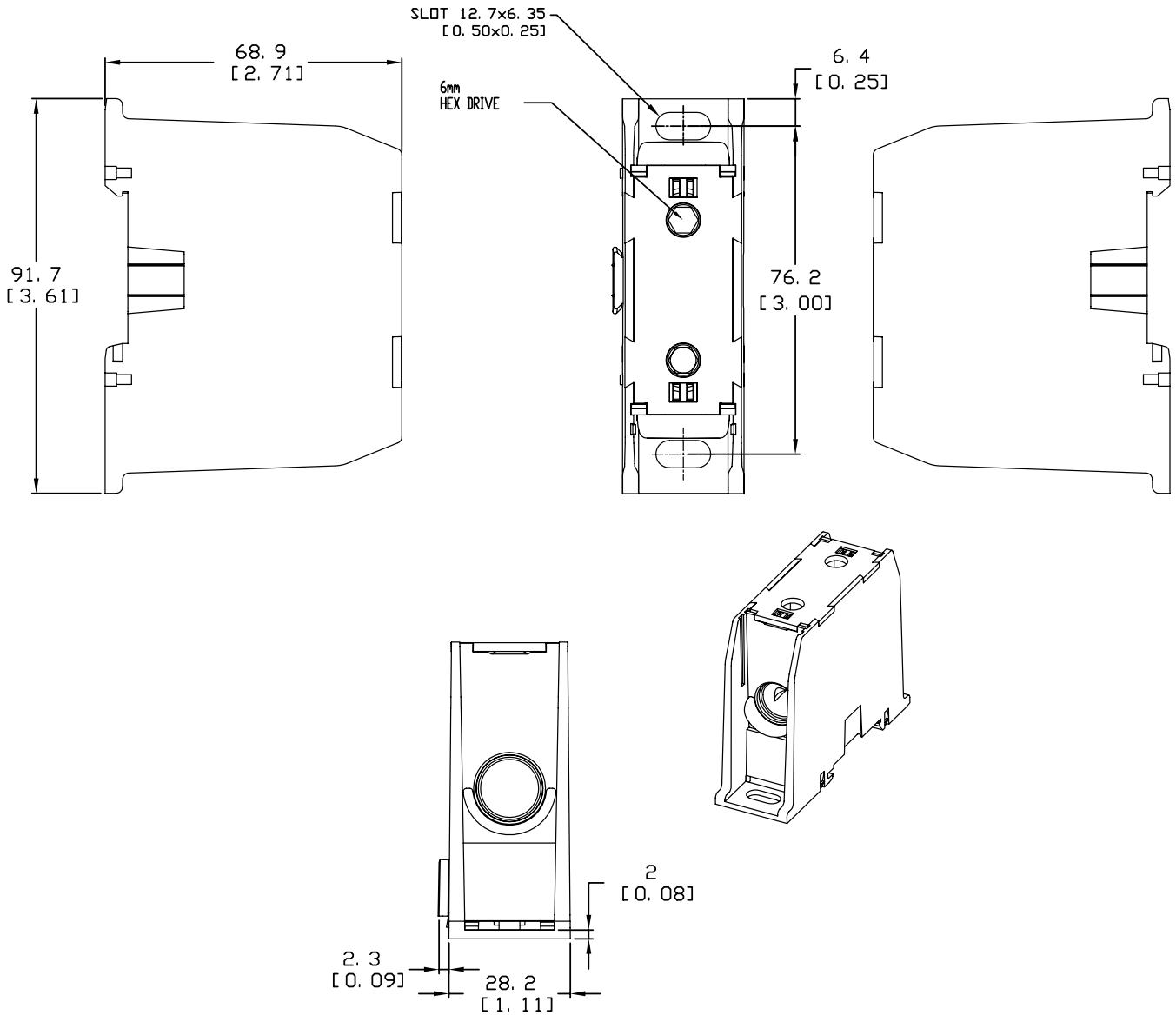

GDB SERIES TOUCH-SAFE POWR-BLOKS

Global Distribution Blocks

Dimensions Millimeters (in)

GDBAD451Z

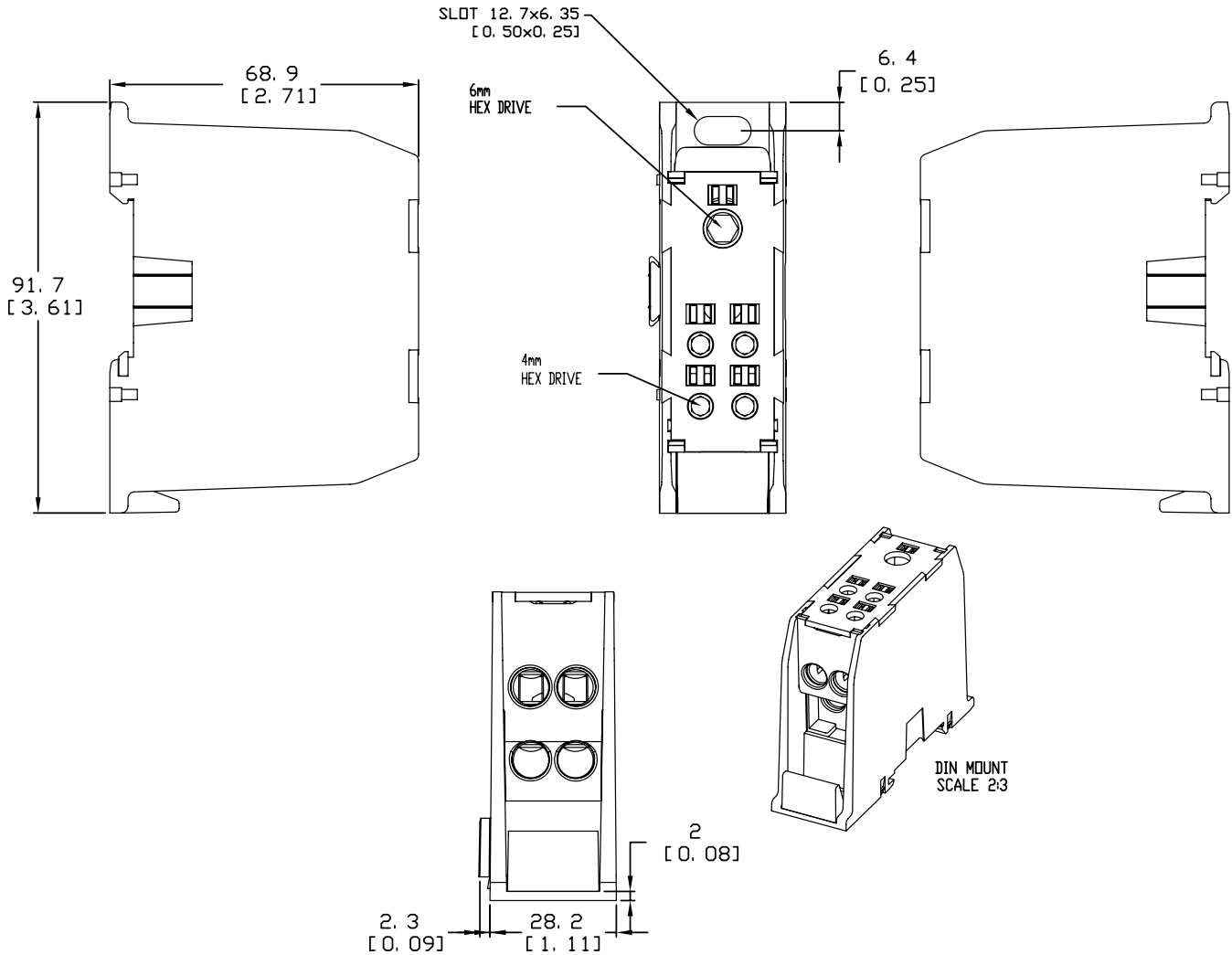

GDB SERIES TOUCH-SAFE POWR-BLOKS

Global Distribution Blocks

Dimensions Millimeters (in)

GDBAP451Z

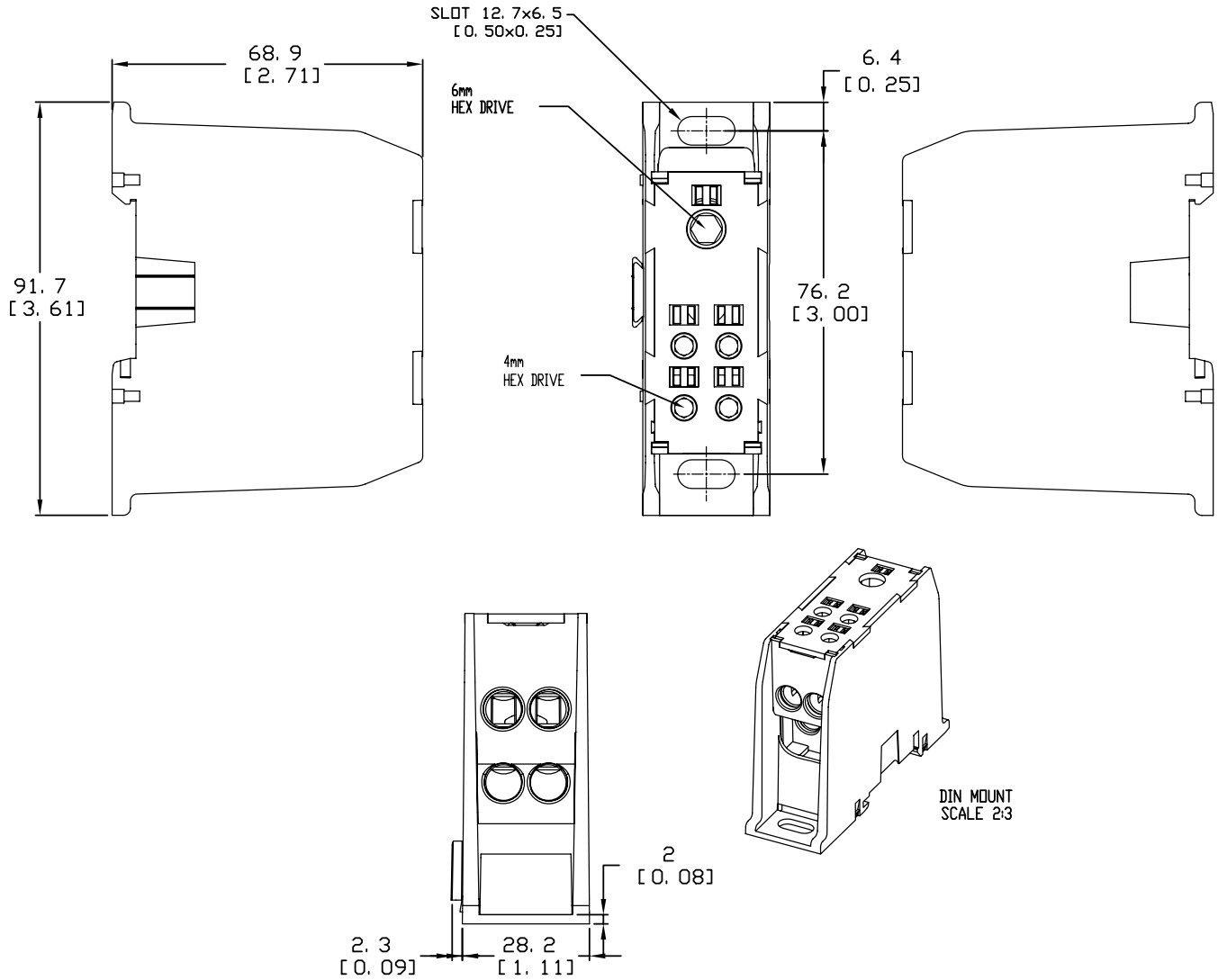

GDB SERIES TOUCH-SAFE POWR-BLOKS

Global Distribution Blocks

Dimensions Millimeters (in)

GDBAD741Z

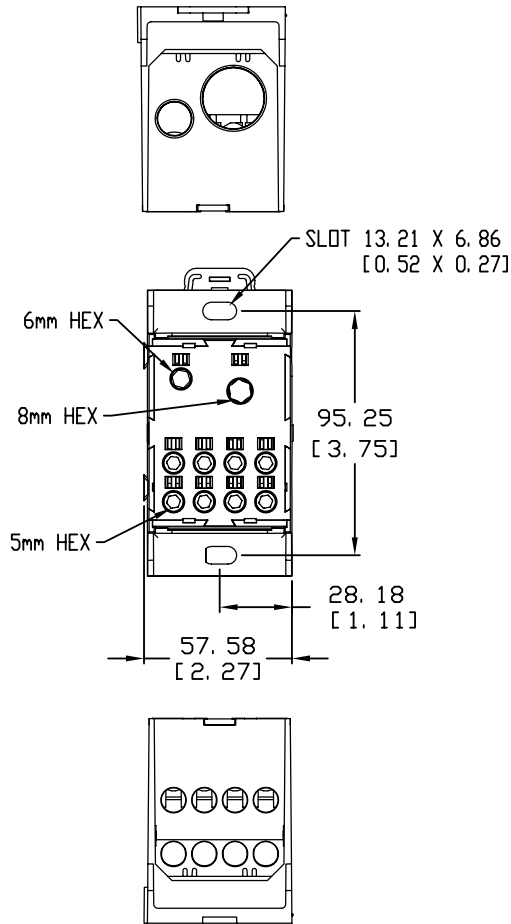
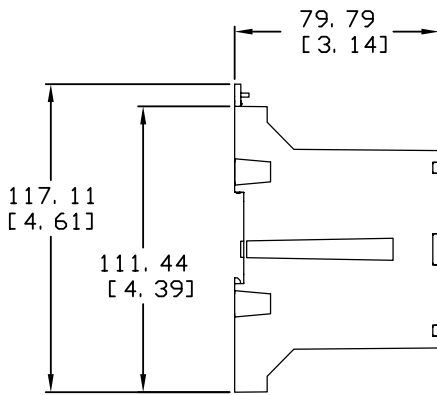

IN-LINE GLASS FUSE HOLDERS

150322



Specifications

Voltage Rating	500 Vac, 125 Vdc
Ampere Rating	15 A
Fuse Type	¼" x 1¼"
Fuse Clips	Tin-plated brass
Wire	Black 18 AWG, 150° C Stranded
Molded Body	Single piece thermoplastic
Flammability Rating	UL94 V-0
Approvals	UL Recognized (File: E14721)
Environmental	RoHS complaint, Lead (Pb) free
Storage Temperature	-40° C to 80° C
Operating Temperature	-55° C to 125° C

Ordering Information

CATALOG NUMBER	ORDERING NUMBER	STANDARD PACK
150322	01500322H	100 PIECES

Description

The 150322 is a 500 Vac/125 Vdc rated inline fuse holder ideal for applications where supplemental protection is needed, such as lighting ballasts and power supplies. 8-inch pre-stripped wire leads and fuse clips come preassembled for quick installation.

Features/Benefits

- Single piece body minimizes component count
- High voltage rating accommodates many power applications
- Wire leads are pre-attached to fuse clips for quick assembly
- Single piece molded body
- UL Recognized

Recommended Fuses

3AG (312, 313 Series)	34
3AB (314, 326, 505 Series)	33

Web Resources

For more information, visit: littelfuse.com/150322

Additional In-Line Glass Fuse Holders

Twist-Lock 155 Series In-Line Mount 32 V 3AG, SFE	Heavy-Duty Bayonet 155 Series In-Line Mount 32 V 3AG	Special Type 150 Series In-Line Mount 250 V 2AG, 5x20mm

Dimensions Inches

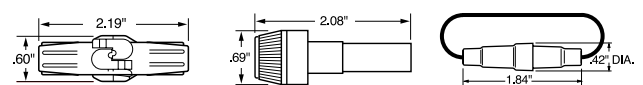

Dimensions mm (inches)

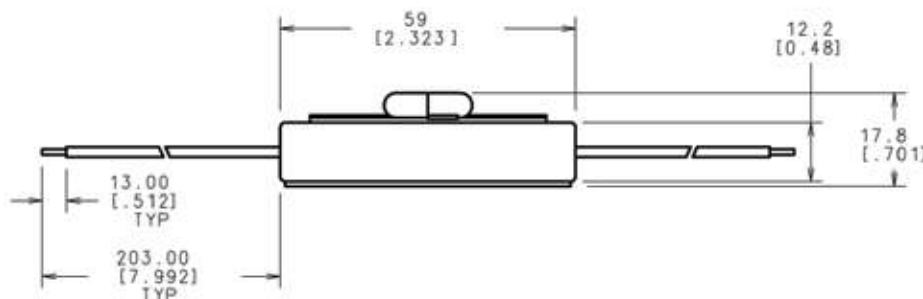

IN-LINE WATERTIGHT FUSE HOLDERS



Description

Recently redesigned, the Littelfuse 600 VAC/VDC in-line watertight fuse holders allow maximum protection for high humidity and corrosive environments. The fuse holders are designed to be touch-safe and flexible for use in a variety of applications. See the list below for the redesigned part numbers.

Applications

- Street lighting and parking lot lighting
- Sports lighting and various outdoor illuminated signs
- Boat electrical circuits, tractors/yard equipment and general outdoor circuit protection (such as traffic signals, alley lighting and electric wheelchairs)

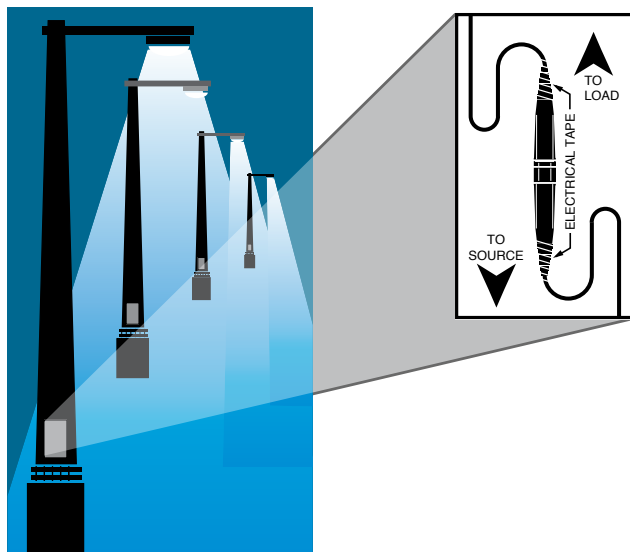

Specifications

Voltage rating	600 VAC/VDC
Ampere rating	up to 30 A
Interrupting rating	200 kA rms symmetrical (with Class CC fuses)
Approvals	<p>LEB/LEX series UL Recognized Miscellaneous Fuse holder per UL UL 4248 (File: E14721) CSA Certified per C22.2, No. 39 (File: LR7316)</p> <p>LEC/LEY series UL Listed Class CC Branch Circuit Fuse holder per UL 512 (File: E14721) CSA Certified per C22.2, No. 39 (File: LR7316)</p>

Features/Benefits

- Design increases safety by individual device disconnection for easy servicing, eliminating shock risk
- Increases efficiency by preventing faulted ballast from severely damaging fixture or device
- Watertight seal
- Variety of terminations available for flexible design
- Insulating boots available for harsh environments

Recommended Fuses

LEB/LEX series:

Accepts all Littelfuse Midget and Class CC series fuses	
CCMR.....	27
KLDR, KLKR.....	28
BLF, BLN, FLM, FLQ, KKK, KLKD	30

LEC/LEY series:

Accepts only Littelfuse Class CC fuses	
CCMR.....	27
KLDR, KLKR.....	28

Web Resources

Download CAD drawings, dimensions and other technical information: littelfuse.com/in-line

Look for these part numbers featuring our improved design

- Better surface area for ergonomic comfort, improved grip and better torque
- More pronounced seating – automatically seats as user begins twisting
- Chamfered edges for additional installation comfort

BASE PART NUMBER	PREVIOUS ORDERING NUMBER	NEW ORDERING NUMBER
LEB-AA	OLEB00AAX	OLEB00AAXK
LEB-AA-S	OLEB0AASX	OLEB0AASXK
LEB-AB	OLEB00ABX	OLEB00ABXK
LEB-AYC-S	OLEBAYCSX	OLEBAYCSXK
LEB-BB	OLEB00BBX	OLEB00BBXK
LEB-JJ	OLEB00JJX	OLEB00JJXK
LEB-JJ-S	OLEB0JJSX	OLEB0JJSXK

IN-LINE WATERTIGHT FUSE HOLDERS

Ordering Information

To order Littelfuse in-line fuse holders by part number, refer to the charts on the next page.

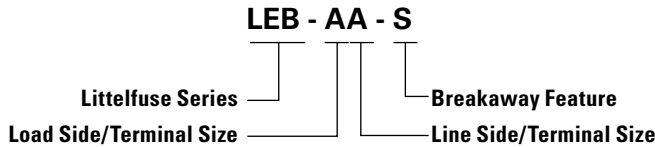

SERIES	DESCRIPTION
LEB	One-pole in-line fuse holder for Midget and Class CC fuses
LEC	One-pole in-line fuse holder for Class CC fuses
LET	One-pole in-line fuse holder with permanently installed solid neutral
LEX	Two-pole in-line fuse holder for Midget and Class CC fuses
LEY	Two-pole in-line fuse holder for Class CC fuses



Recommended Crimping Tools

The following crimping tools or equivalents may be used on either the non-breakaway or breakaway watertight in-line fuse holders.

TERMINAL SIZE	T&B PART NUMBER	BURNDY PART NUMBER
A	WT161M	-
B	WT161M	MR4C
C	M5-GREY	Hypress Y34A
D	M5-BROWN	Hypress Y34A

Insulating Boots

- Molded from engineering-grade thermoplastics which provide high resistance to corrosive environments
- Standard with all breakaway style fuse holders
- For watertight protection of non-breakaway Y-pole termination, order one WPB1 and one WPB3 boot



ORDERING NUMBER	TERMINAL TYPE
WPB1	A, B, C, D, J
WPB3	Y

Dimensions Inches

1-Pole

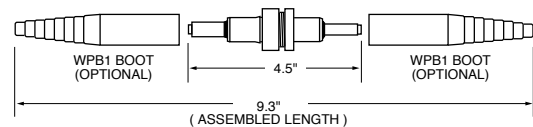

1-Pole Breakaway

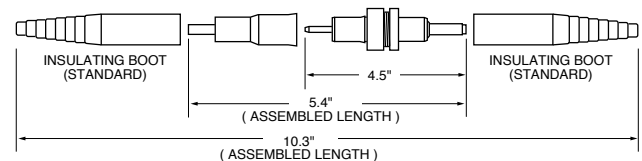

2-Pole

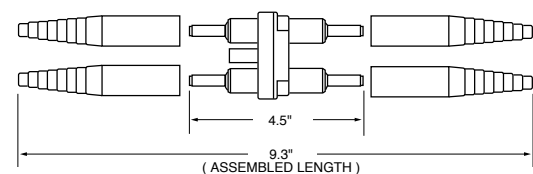

2-Pole Breakaway

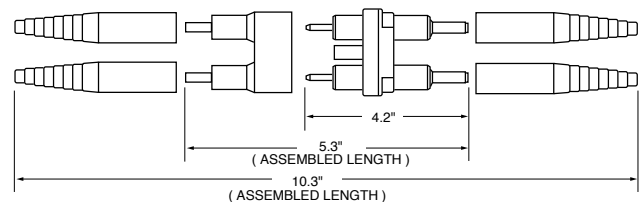

IN-LINE WATERTIGHT FUSE HOLDERS

Ordering Information (1-Pole LEB/LEC and 2-Pole LEX/LEY for Class CC and Midget Fuses)

SINGLE POLE		DOUBLE POLE		LOAD TERMINAL SELECTION					LINE TERMINAL SELECTION				
STANDARD PART NUMBER	BREAKAWAY PART NUMBER	STANDARD PART NUMBER	BREAKAWAY PART NUMBER	TERMINAL TYPE	LOAD TERMINAL WIRE SIZE RANGE	NUMBER OF WIRES PER TERMINAL	SOLID WIRE	STRANDED WIRE	TERMINAL TYPE	LINE TERMINAL WIRE SIZE RANGE	NUMBER OF WIRES PER TERMINAL	SOLID WIRE	STRANDED WIRE
LEB-AA-K LEC-AA	LEB-AA-SK LEC-AA-S	LEX-AA LEY-AA	LEX-AA-S LEY-AA-S	Copper Crimp	#12 to #8 #12	1 2	• •	• •	Copper Crimp	#12 to #8 #12	1 2	• •	• •
LEB-AB-K LEC-AB	LEB-AB-S LEC-AB-S	LEX-AB LEY-AB	LEX-AB-S LEY-AB-S	Copper Crimp	#12 to #8 #12	1 2	• •	• •	Copper Crimp	#10 #6 #4	2 1 1	• • —	• • •
LEB-AC LEC-AC	— —	LEX-AC LEY-AC	— —	Copper Crimp	#12 to #8 #12	1 2	• •	• •	Copper Crimp	#8 #4	2 1	• —	• •
LEB-AD LEC-AD	— —	LEX-AD LEY-AD	— —	Copper Crimp	#12 to #8 #12	1 2	• •	• •	Copper Crimp	#6 #2	2 1	• —	• •
LEB-AJ LEC-AJ	LEB-AJ-S LEC-AJ-S	— —	— —	Copper Crimp	#12 to #8 #12	1 2	• •	• •	Copper Set-Screw	#12 to #8 #10 to #2	1 1	• —	— •
LEB-AYC LEC-AYC	LEB-AYC-SK LEC-AYC-S	LEX-AYC LEY-AYC	LEX-AYC-S LEY-AYC-S	Copper Crimp	#12 to #8 #12	1 2	• •	• •	"Y" Type Copper Set-Screw	#12 to #8 #10 to #2	1 1	• —	— •
LEB-BA LEC-BA	LEB-BA-S LEC-BA-S	LEX-BA LEY-BA	LEX-BA-S LEY-BA-S	Copper Crimp	#10 #6 #4	2 1 1	• • —	• • •	Copper Crimp	#12 to #8 #12	1 2	• • •	• • •
LEB-BB-K LEC-BB	LEB-BB-S LEC-BB-S	LEX-BB LEY-BB	LEX-BB-S LEY-BB-S	Copper Crimp	#10 #6 #4	2 1 1	• • —	• • •	Copper Crimp	#10 #6 #4	2 1 1	• • —	• • •
LEB-BC LEC-BC	— —	LEX-BC LEY-BC	— —	Copper Crimp	#10 #6 #4	2 1 1	• • —	• • •	Copper Crimp	#8 #4	2 1	• —	• •
LEB-BD LEC-BD	— —	LEX-BD LEY-BD	— —	Copper Crimp	#10 #6 #4	2 1 1	• • —	• • •	Copper Crimp	#6 #2	2 1	• —	• •
LEB-BJ LEC-BJ	LEB-BJ-S LEC-BJ-S	— —	— —	Copper Crimp	#10 #6 #4	2 1 1	• • —	• • •	Copper Set-Screw	#12 to #8 #10 - #2	1 1	• —	— •
LEB-BYC LEC-BYC	LEB-BYC-S LEC-BYC-S	LEX-BYC LEY-BYC	LEX-BYC-S LEY-BYC-S	Copper Crimp	#10 #6 #4	2 1 1	• • —	• • •	"Y" Type Copper Set-Screw	#12 to #8 #10 - #2	1 1	• —	— •
LEB-CA LEC-CA	— —	LEX-CA LEY-CA	— —	Copper Crimp	#8 #4	2 1	• —	• •	Copper Crimp	#12 to #8 #12	1 2	• • •	• • •
LEB-CB LEC-CB	— —	LEX-CB LEY-CB	— —	Copper Crimp	#8 #4	2 1	• —	• •	Copper Crimp	#10 #6 #4	2 1 1	• • —	• • •
LEB-CC LEC-CC	— —	LEX-CC LEY-CC	— —	Copper Crimp	#8 #4	2 1	• —	• •	Copper Crimp	#8 #4	2 1	• —	• •
LEB-CD LEC-CD	— —	LEX-CD LEY-CD	— —	Copper Crimp	#8 #4	2 1	• —	• •	Copper Crimp	#6 #2	2 1	• —	• •
LEB-CJ LEC-CJ	— —	LEX-CJ LEY-CJ	— —	Copper Crimp	#8 #4	2 1	• —	• •	Copper Set-Screw	#12 to #8 #10 - #2	1 1	• —	• •
LEB-CYC LEC-CYC	— —	LEX-CYC LEY-CYC	— —	Copper Crimp	#8 #4	2 1	• —	• •	"Y" Type Copper Set-Screw	#12 to #8 #10 to #2	1 1	• —	— •
LEB-DA LEC-DA	— —	LEX-DA LEY-DA	— —	Copper Crimp	#6 #2	2 1	• —	• •	Copper Crimp	#12 to #8 #12	1 2	• • •	— • •
LEB-DB LEC-DB	— —	LEX-DB LEY-DB	— —	Copper Crimp	#6 #2	2 1	• —	• •	Copper Crimp	#10 #6 #4	2 1 1	• • —	• • •
LEB-DC LEC-DC	— —	LEX-DC LEY-DC	— —	Copper Crimp	#6 #2	2 1	• —	• •	Copper Crimp	#8 #4	2 1	• —	• •
LEB-DD LEC-DD	— —	LEX-DD LEY-DD	— —	Copper Crimp	#6 #2	2 1	• —	• •	Copper Crimp	#6 #2	2 1	• —	• •
LEB-DJ LEC-DJ	— —	LEX-DJ LEY-DJ	— —	Copper Crimp	#6 #2	2 1	• —	• •	Copper Set-Screw	#12 to #8 #10 - #8	2 1	• —	• •
LEB-DYC LEC-DYC	— —	LEX-DYC LEY-DYC	— —	Copper Crimp	#6 #2	2 1	• —	• •	"Y" Type Copper Set-Screw	#12 to #8 #10 to #8	1 1	• —	— •
LEB-JJ-K LEC-JJ	LEB-JJ-SK LEC-JJ-S	LEX-JJ LEY-JJ	LEX-JJ-S LEY-JJ-S	Copper Set-Screw	#12 to #8 #10 to #2	1 1	• —	— •	Copper Set-Screw	#12 to #8 #10 to #2	1 1	• —	— •
LEB-JYC LEC-JYC	LEB-JYC-S LEC-JYC-S	— —	— —	Copper Set-Screw	#12 to #8 #10 to #2	1 1	• —	— •	"Y" Type Copper Set-Screw	#12 to #8 #10 to #2	1 1	• —	— •

IN-LINE WATERTIGHT FUSE HOLDERS

Ordering Information (Solid Neutral LET Fuse Holders)

STANDARD PART NUMBER	BREAKAWAY PART NUMBER	FUSE TYPE	LOAD TERMINAL SELECTION					LINE TERMINAL SELECTION				
			TERMINAL TYPE	LOAD TERMINAL WIRE SIZE RANGE	NUMBER OF WIRES PER TERMINAL	SOLID WIRE	STRANDED WIRE	TERMINAL TYPE	LINE TERMINAL WIRE SIZE RANGE	NUMBER OF WIRES PER TERMINAL	SOLID WIRE	STRANDED WIRE
LET-AA	LET-AA-S	Solid Neutral	Copper Crimp	#12 to #8 #12	1 2	• •	• •	Copper Crimp	#12 to #8 #12	1 2	• •	• •
LET-AB	LET-AB-S	Solid Neutral	Copper Crimp	#12 to #8 #12	1 2	• •	• •	Copper Crimp	#10 #6 #4	2 1 1	• • —	• • •
LET-AYC	LET-AYC-S	Solid Neutral	Copper Crimp	#12 to #8 #12	1 2	• •	• •	"Y" Type Copper Set-Screw	#12 to #8 #10 to #2	1 1	• —	— •
LET-BA	LET-BA-S	Solid Neutral	Copper Crimp	#10 #6 #4	2 1 1	• • —	• • •	Copper Crimp	#12 to #8 #12	1 2	• •	• •
LET-BB	LET-BB-S	Solid Neutral	Copper Crimp	#10 #6 #4	2 1 1	• • —	• • •	Copper Crimp	#10 #6 #4	2 1 1	• • —	• • •
LET-BYC	LET-BYC-S	Solid Neutral	Copper Crimp	#10 #6 #4	2 1 1	• • —	• • •	"Y" Type Copper Set-Screw	#12 to #8 #10 to #2	1 1	• —	— •
LET-JJ	LET-JJ-S	Solid Neutral	Copper Set-Screw	#12 to #8 #10 to #2	1 1	• —	— •	Copper Set-Screw	#12 to #8 #10 to #2	1 1	• —	— •
LET-JYC	LET-JYC-S	Solid Neutral	Copper Set-Screw	#12 to #8 #10 to #2	1 1	• —	— •	"Y" Type Copper Set-Screw	#12 to #8 #10 to #2	1 1	• —	— •

Ordering Information (Terminals)

TERMINAL DESIGNATION	TERMINAL DESCRIPTION	NUMBER OF WIRES PER TERMINAL	WIRE RANGE	SOLID WIRE	STRANDED WIRE
A	Copper Crimp	1	#12-#8	•	•
		2	#12	•	•
B	Copper Crimp	1	#10	•	•
		1	#6	•	•
		1	#4	—	•
C	Copper Crimp	2	#8	•	•
		1	#4	—	•
D	Copper Crimp	2	#6	•	•
		1	#2	—	•
J	Copper Set-Screw	1	#12-#8	•	—
		1	#10-#2	—	•
Y (2 terminals)	"Y" Style Copper Set-Screw	1	#12-#8	•	—
		1	#10-#2	—	•

IN-LINE WATERTIGHT FUSE HOLDERS

Two-Pole Breakaway Holder



Features/Benefits

- LEXT-YY version has a permanently installed “neutral” slug to prevent the neutral from accidentally being fused
- LEX-YYC version allows for fusing of line-to-line loads or other applications requiring two fuses to disconnect under strain
- Fiberglass polymer body resists damage from impact
- Four “Y” type set-screw terminals accommodate a wide range of solid and stranded copper conductors
- O-ring and terminal boots form watertight seal, preventing leakage

Specifications

Part numbers	LEXT-YY-S (Solid neutral) LEX-YYC-S
Voltage Rating	600 Vac/Vdc
Ampere Rating	30 A
Interrupting Rating	200 kA with Class CC Fuses
Y Terminals	Tin Plated Copper w/ set screws
Wire Size	1 solid #12 to #8 or 1 stranded #10 to #2
Approvals	UL Recognized (File: E14721) CSA Certified (File: LR7316)

Description

New Littelfuse LEXT-YY-S and LEX-YYC-S series breakaway fuse holders meet state and federal highway commission safety standards requiring fuse holders to readily disconnect from power in case of a pole knockdown.

The breakaway feature consists of a receptacle permanently attached to the power line and a fuse holder with matching terminals. If a knockdown occurs, the parts separate, leaving the energized conductor recessed and unexposed.

Applications

- Street lighting
- Marinas
- Travel trailer parks
- Physically strained fuse holders applications

Recommended Fuses

Accepts all Littelfuse Midget and Class CC series fuses	
CCMR.....	27
KLDR, KLKR.....	28
BLF, BLN, FLM, FLO, KKK, KLKD	30

Four WPB3 insulating boots come standard with the LEXT-YY-S and LEX-YYC-S fuse holders. Molded from non-conductive engineering grade thermoplastic to deliver a watertight seal in corrosive environments, they can be trimmed to the specific conductor size insuring a snug fit.

Web Resources

Additional technical information:
littelfuse.com/in-line

Ordering Information

ORDERING NUMBER	FUSE TYPE	LOAD TERMINAL SELECTION						LINE TERMINAL SELECTION				
		TERMINAL TYPE	LOAD TERMINAL WIRE SIZE RANGE	NUMBER OF WIRES PER TERMINAL	SOLID WIRE	STRANDED WIRE	TERMINAL TYPE	LINE TERMINAL WIRE SIZE RANGE	NUMBER OF WIRES PER TERMINAL	SOLID WIRE	STRANDED WIRE	
LEXTYYS	LEXTOYYSX	Midget Class CC	“Y” type Copper Set-Screw	#12 to #8	1	•	—	“Y” type Copper Set-Screw	#12 to #8	1	•	—
				#10 to #2	1	—	•		#10 to #2	1	—	•
LEXYYS	OLEXYYSX	Midget Class CC	“Y” type Copper Set-Screw	#12 to #8	1	•	—	“Y” type Copper Set-Screw	#12 to #8	1	•	—
				#10 to #2	1	—	•		#10 to #2	1	—	•

IN-LINE WATERTIGHT FUSE HOLDERS

Two-Pole Breakaway Holder

Dimensions Inches

LEX-YY-C-S

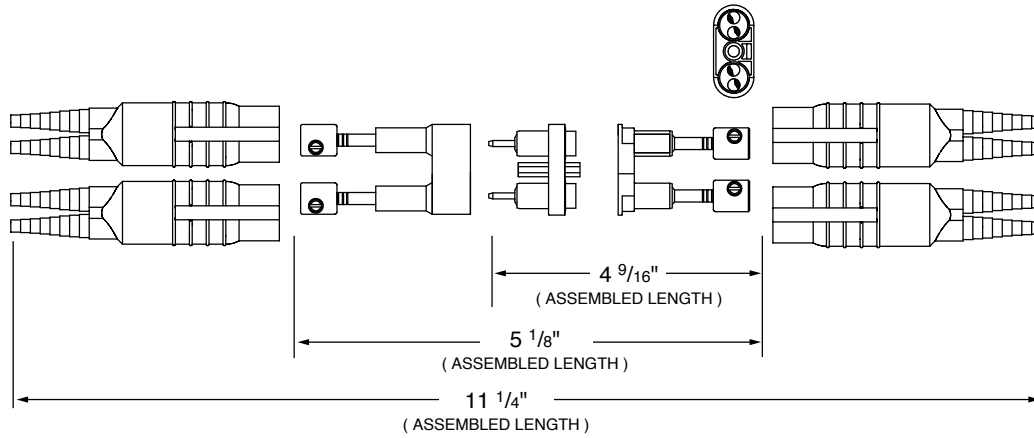

LEXT-YY-S

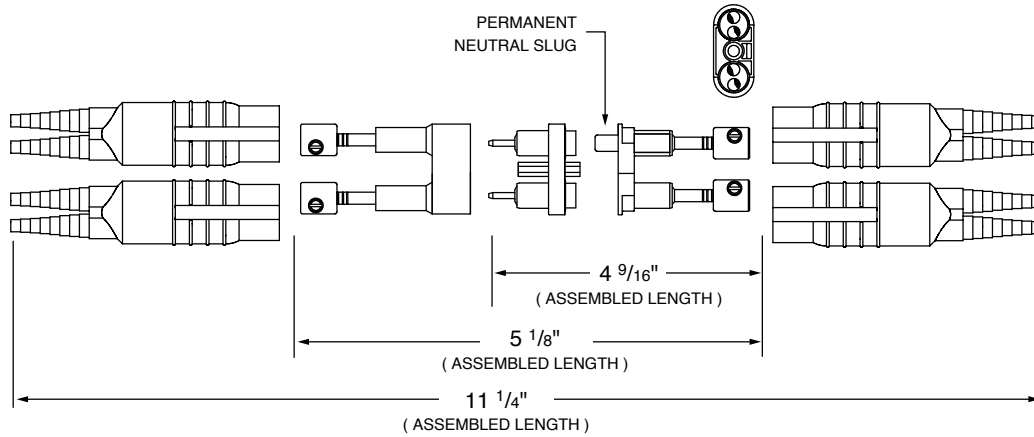

Section Overview

POWR-GARD's Pre-Engineered Solutions include custom-built electrical panels designed specifically to meet NEC® requirements, as well as fused and non-fused disconnect switches.



PRE-ENGINEERED SOLUTIONS



Table of Contents

LCP Fused Selective Coordination Panel.....	157
LPS Series POWR-Switch (Shunt Trip Disconnect).....	159

LCP FUSED COORDINATION PANEL

Selective Coordination Panel



Description

The Littelfuse® Coordination Panel provides a simple, time-saving solution for circuits that require selective coordination. This UL Listed product saves time and money, and increases safety by minimizing system downtime.

Applications

- Elevators
- Hospitals
- Hotel and Entertainment Industry
- Amusement Parks and Stadiums

Code Requirements

Systems required by the NEC® to be selectively coordinated include:

- Health Care Essential Electrical Systems (NEC 517.26)
- Elevators (NEC 620.62)
- Emergency Systems (NEC 700.32 in 2017) (NEC 700.28 in 2014)
- Legally Required Standby Systems (NEC 701.18)
- Critical Operations Power Systems (NEC 708.54)

Features/Benefits

- Meets NEC® requirements
- Class CC and J fuse holders have built-in open-circuit indication
- Fast-acting UL Listed fuses protect against short circuits
- Feed through/sub feed lugs and 84-circuit configuration available
- Ground and neutral bars
- Copper bus standard

Advanced Design Options

- MLO, Main Circuit Breaker, or Main Fused Pullout device
- Fused Class T branch circuit pullout
- Spare fuse cabinet accessory (holds six spare fuses)
- SPD overvoltage protection
- Any NEMA enclosure required
- High amperage sub-fed branch breakers (J60A)

Specifications

Voltage Ratings	120/208, 120/240, 277/480 VAC
Main Bus Rating	100 A - 400 A Standard
Conductor Terminals	6 AWG - 300 kcmil
UL Listed	UL 67 Panel boards and UL 50 Enclosures
SCCR	100 kA Max*

* The following current-limiting fuses must be used directly upstream for 100kA SCCR.

1. 120/208 Volt Panels – LLNRK 100 A max, JTD_ID 200 A max, or JLLN 200 A max
2. 120/240 Volt Panels – LLSRK_ID 200 A max, JTD_ID 200 A max, or JLLS 200 A max
3. 277/480 Volt Panels – LLSRK_ID 200 A max, JTD_ID 200 A max, or JLLS 200 A max

Web Resources

For more information, visit: littelfuse.com/lcp

Customizable Options (select one from each column)

NUMBER OF CIRCUITS	VOLTAGE	MAIN DEVICES	NEUTRAL RATING	PANEL MOUNTING	PANEL DOOR	FUSE HOLDERS	BRANCH CIRCUIT PROTECTION DEVICES (1-3 POLE)†	PANEL FEED	OPTIONAL LUGS	STANDARD ENCLOSURE RATING
2 - 42	120/208 V 3P, 4 W 120/240 V 1P, 3 W 277/480 V 3P, 4 W	125, 225, 400 or 600 A MLO Up to 600 A MCB or Main Fuse Pullout	100% 200%	Surface Flush	Standard Door-in-door	30 A Class CC 60 A Class J >100A Class T	10 A- 60 A fused circuit breaker 70 A-200 A fused pullouts Sub-fed circuit breakers >60 A (not fused)	Top Bottom	None Sub-Fed (MLO panels) Feed-Through	NEMA 1 NEMA 3R NEMA 4X NEMA 12

†Fuses quoted separately to meet panel specifications. Coordination for breakers >60 A depends on upstream and downstream devices. More specialized configurations are also available. Contact factory for more information.

Note: The Littelfuse LPS and LCP products are custom designed products that fall outside standard specifications.

LCP FUSED COORDINATION PANEL

Selective Coordination Panel

Dimensions mm (inches)

Standard Coordination Panel Board (up to 30 circuits)

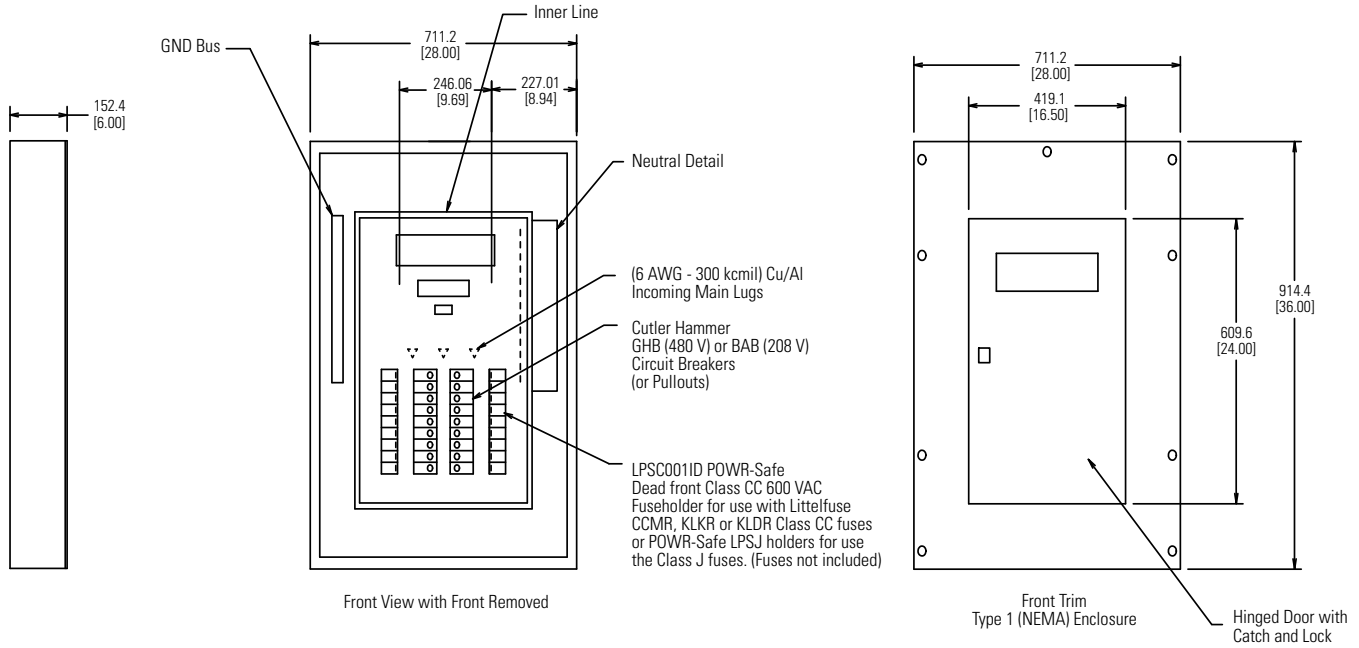

Standard Coordination Panel Board (31-42 circuits)

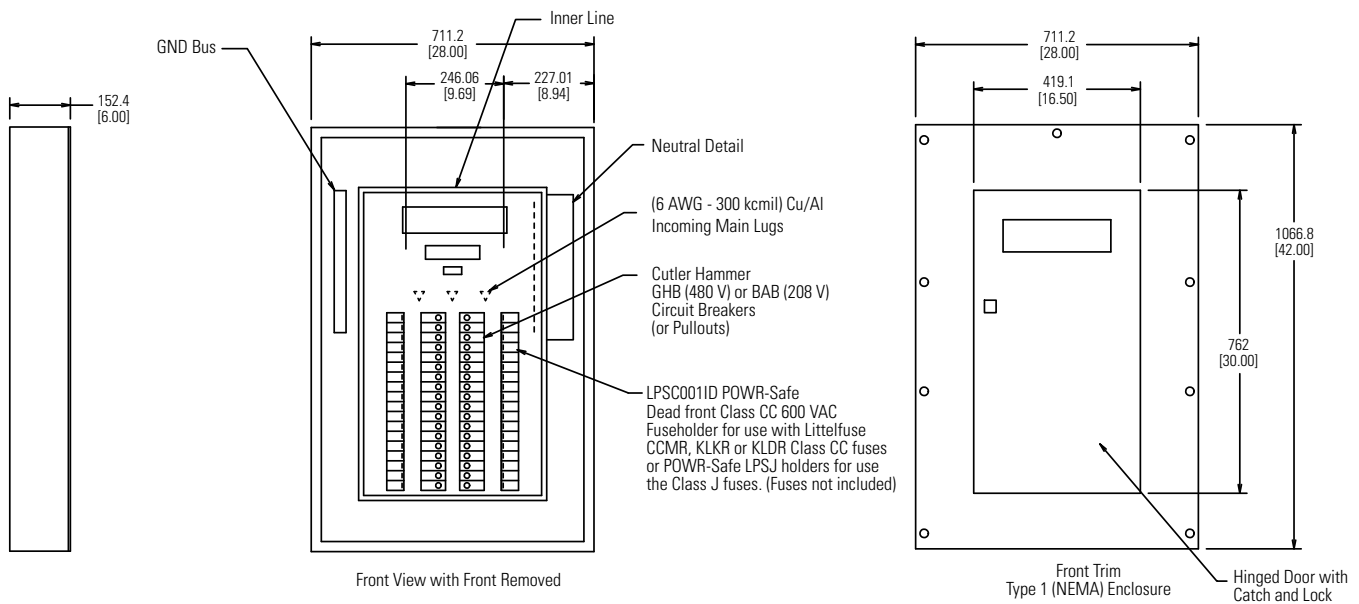

Note: The Littelfuse LCP Series products are custom designed products that fall outside standard specifications.

Dimensions may change depending on panel components.
More specialized configurations are also available.
Contact factory for more information.

LPS SERIES SHUNT TRIP DISCONNECT SWITCH



Description

The Littelfuse® LPS Series provides a simple and economical solution for applications that require selective coordination and shunt trip capabilities.

Utilizes Class J time-delay fuses that are easily coordinated with other system overcurrent devices. The shunt trip capability allows the LPS Series to meet the ANSI/ASME standard that requires power to be automatically disconnected before water is turned on by the fire safety system.

Applications

- Elevator circuits
- Data processing rooms
- Building emergency systems

Web Resources

Download technical information: littelfuse.com/lps

Specifications (Disconnect Switch)

Supply Voltage Rating*	208 V, 240 V, 480 V
Ampere Range	30 A, 60 A, 100 A, 200 A, 400 A
Enclosures	NEMA 1 (standard) NEMA 3R, NEMA 4, NEMA 12 (optional)
Approvals	UL Listed (File: E219511)

*Contact factory for 600 V options.

Specifications (Shunt Trip)

Voltage Rating	120 V, 60 Hz
Max Inrush	4 A
Max On time	1.5 cycles
Momentary Inrush	140 VA

Features/Benefits

- Pre-engineered single unit, which makes procurement easier than systems with multiple components
- Reduces labor costs up to 66% and total installation costs by over 30%
- Pre-installed UL Listed Class J fuse holder – unique Class J size eliminates the need for any rejection type fuse clips
- Optional features offer flexibility for a variety of applications
- Color coded control power terminal blocks
- UL Listed package
- Cu and Al wire rated
- Pre-wired control circuits lower installation time
- Lockable operating handle meets all code and safety requirements (accepts up to 3 locks)
- Every unit is fully tested before delivery

Options

- Control power transformer with fuses and blocks
- Fire safety interface relay
- Key to test switch
- Pilot light "On"
- Isolated neutral lug
- Mechanical interlock auxiliary contact for hydraulic elevators with automatic recall (5 amp 120 Vac rated)
- Fire alarm voltage monitoring relay
- Option to bypass alarm when performing maintenance (-AZ option)
- XPress-Ship™ service offers 48 hours direct shipment service on select fully loaded LPS Series Shunt Trip Disconnect Switches

LPS SERIES SHUNT TRIP DISCONNECT SWITCH



Ordering Information

Complete catalog numbers consist of switch catalog numbers and the desired options. See example below.

Example Catalog Number from Desired Options

LPS1 T20 R1 K G N1 B F3 U - AZ = Littelfuse Catalog Number LPS1T20R1KGN1BF3U-AZ

LITTELFUSE SWITCH CATALOG NUMBER		CONTROL POWER TRANSFORMER STD. 100VA WITH PRI & SEC FUSE (120 V SEC.)		FIRE SAFETY INTERFACE RELAY (3 PDT, 10 A, 120 V)		KEY TO TEST SWITCH		PILOT LIGHT "ON"		ISOLATED NEUTRAL LUG		MECHANICAL INTERLOCK AUX. CONTACT FOR HYDRAULIC ELEVATORS W/ AUTOMATIC RECALL (5 A, 120 VAC)		FIRE ALARM SHUNT TRIP VOLTAGE MONITORING RELAY		OPTIONAL ENCLOSURES		AZ OPTION (BYPASS FIRE ALARM DURING MAINT. TEST)	
REQUIRED		REQUIRED		REQUIRED		OPTIONAL		OPTIONAL		OPTIONAL		REQUIRED		REQUIRED		OPTIONAL		OPTIONAL	
BASE CATALOG #	RATING	RATING	OPTION CODE	RATING	OPTION CODE	RATING	OPTION CODE	RATING	OPTION CODE	RATING	OPTION CODE	RATING	OPTION CODE	RATING	OPTION CODE	RATING	OPTION CODE	OPTION CODE	
LPS3*	30 A	208 V	T20	24 VDC Coil	R2	120 V	K	Red	R	30-60 A	N6	1 NO & 1 NC	A	1-Pole	F1	NEMA 3R	U	-	AZ
LPS6*	60 A	240 V	T24	120 VAC Coil	R1			Green	G			2 NO & 2 NC	B	3-Pole	F3	NEMA 4	Y	-	
LPS1*	100 A	480 V	T48					White	W	100 A	N1					NEMA 12	Z	-	
LPS2*	200 A									200 A	N2							-	
LPS4*	400 A									400 A	N4							-	

*Part Numbers: Any voltage can be paired with any amperage. Options can be any combination but the ratings must match the option code. Not all options are required. Contact factory for 600 V control power transformer option.

Note: When ordering - desired options must be listed in the order shown above. Typical options include Control Power Transformer, Fire Safety Interface Relay, Mechanical Interlock Auxiliary Contact and Fire Alarm Voltage Monitoring Relay.

Dimensions of Enclosure

CATALOG SERIES	AMPERE RATING	NEMA 1 DIMENSIONS	NEMA 3R DIMENSIONS	NEMA 4, 12 DIMENSIONS	LUG SIZE	SHIPPING WEIGHT (LBS)
LPS3	30	24"H x 20"W x 9"D	24"H x 20"W x 8"D	24"H x 20"W x 10"D	#14 - #8 AL or CU	75
LPS6	60	24"H x 20"W x 9"D	24"H x 20"W x 8"D	24"H x 20"W x 10"D	#14 - #2 AL or CU	75
LPS1	100	24"H x 20"W x 9"D	24"H x 20"W x 8"D	24"H x 20"W x 10"D	#8 - 1/0 AL or CU	75
LPS2	200	30"H x 20"W x 9"D	30"H x 24"W x 8"D	30"H x 20"W x 10"D	#6 - 250kcmil AL or CU	85, 115*, 120**
LPS4	400	48"H x 36"W x 10"D	48"H x 36"W x 12"D	48"H x 36"W x 10"D	3/0 AL or CU	225

* NEMA 3R

** NEMA 4 & NEMA 12

Note: Over-size enclosures used to accommodate control power transformer, interface relay and terminal blocks.

XPress-Ship™

US Only

Littelfuse XPress-Ship™ service offers 48 hours** direct-shipment service on select fully-loaded LPS Series Shunt Trip Disconnect Switches to meet your urgent system requirements on time.

XPress-Ship™ switches include three JTD_ID Series fuses rated at the device's maximum ampacity.

AMPERE RATING	VOLTAGE RATING	CATALOG NUMBER	XPress-Ship™ ORDERING NUMBER
60 A	480 V	LPS6T48R1KGN6BF3-AZ	XPS6T48R1KGN6F3-AZ*
100 A	480 V	LPS1T48R1KGN1BF3-AZ	XPS1T48R1KGN1F3-AZ*
100 A	480 V	LPS1T48R1KGN1BF3	XPS1T48R1KGN1BF3
200 A	208 V	LPS2T20R1KGN2BF3-AZ	XPS2T20R1KGN2F3-AZ*
200 A	480 V	LPS2T48R1KGN2BF3	XPS2T48R1KGN2BF3

*AZ option includes B & F3 options.

**XPress-Ship™ 48 hour service requires ordering from XPress-Ship™ Ordering Numbers shown above and is subject to a maximum of any combination of three switches per customer order. XPress-Ship™ service offers 48 hour shipment from the factory through standard ground transportation. For expedited delivery, contact your local Littelfuse Representative.

LPS SERIES SHUNT TRIP DISCONNECT SWITCH

Shunt-Trip Operation

The disconnecting means is a shunt-trip operated switch. The control power source for the shunt-trip operator is a 120 Vac supply originating in the Littelfuse LPS Series shunt trip disconnect switch. Current to the shunt-trip device is switched by an isolation relay, which is in turn controlled by the FACP (Fire Alarm Control Panel).

The control signal may be either 24 Vdc from the FACP (option R2) or a “dry” contact closure in the FACP (option R1). In the case of a “dry” contact closure, the sensing voltage is 120 VAC originating in the Littelfuse LPS Series shunt trip disconnect switch.

CAUTION: When using the “dry” contact closure, option 1, DO NOT supply 120 Vac from the FACP as equipment damage or personnel injury may occur.

A key test option (option K) is available to test the shunt-trip circuit.

Supervisory Indication

Additionally, an optional separate relay can be specified to monitor the 120 Vac control power source in the Littelfuse POWR-Switch LPS Series disconnect. This relay (option FR) is used to provide supervisory indication of “Control Power Available” as required by NFPA 72 Section 6.15.4.4.

Fuse Table

POWR-SWITCH VOLTAGE/ TRANSFORMER TYPE	PRIMARY FUSES (2)		SECONDARY FUSE (1)	
	FUSE TYPE	FUSE RATING (AMPS)	FUSE TYPE	FUSE RATING (AMPS)
208/120 Vac	KLDR001	1	FLM1.12	1-1/8
240/120 Vac	KLDR500	1/2	FLM1.12	1-1/8
480/120 Vac	KLDR400	4/10	FLM1.12	1-1/8
600/120 Vac	KLDR250	1/4	FLM1.12	1-1/8

All Littelfuse LPS Series shunt trip disconnect switches are UL Listed and designed for safe access by qualified personnel. When maintenance or shutdown service is required, no energized parts are exposed inside the enclosure when the disconnect switch is manually turned to the OFF position. For proper maintenance safety precautions, always turn off incoming power to the Littelfuse LPS Series shunt trip disconnect switch when possible. When servicing any live electrical equipment, always wear appropriate personal protective equipment.

Power Wiring Torque Specifications

CHARACTERISTICS	LPS3	LPS6	LPS1	LPS2	LPS4
Amps	30	60	100	200	400
AWG	10	6	3	3/0	(2) 3/0
Molded Case Switch (MCS) Mfr.	ABB	ABB	ABB	ABB	ABB
MCS Catalog No.	TS3H150DBBS4	TS3H150DBBS4	TS3H150DBBS4	TS3H225DQQS4	T5H400DWS4
MCS Lug Type	K4TB	K4TB	K4TB	K4TD	KT5400-3
MCS Lug Torque (in-lbs)	50 in-lb*	50 in-lb*	50 in-lb*	200 in-lb*	275 in-lb*
Fuse Block Mfr.	LITTELFUSE	LITTELFUSE	LITTELFUSE	LITTELFUSE	LITTELFUSE
Fuse Block Catalog No.	LFJ60030-3	LFJ60060-3	LFJ60100-3	LFJ60200-3	LFJ60400-3
Fuse Lug Torque (in-lbs)	25 in-lb†	45 in-lb†	120 in-lb†	275 in-lb†	275 in-lb†
Neutral Lug Mfr.	LITTELFUSE	LITTELFUSE	LITTELFUSE	LITTELFUSE	LITTELFUSE
Neutral Lug Catalog No.	LS21211	LS21211	LS21211	LS31231	LS455712
Neutral Lug Torque (in-lbs)	35 in-lb†	45-120 in-lb†	120 in-lb†	275 in-lb†	500 in-lb†
Ground Lug Mfr.	PANDUIT	PANDUIT	PANDUIT	PANDUIT	PANDUIT
Ground Lug Catalog No.	LAMA 1/0-14-Q	LAMA 1/0-14-Q	LAMA 1/0-14-Q	LAMA 250-56-Q	LAMA 350-38-Q
Ground Lug Torque	25 in-lb†	45 in-lb†	120 in-lb†	275 in-lb†	275 in-lb†

Note: Torque specs apply only to wire compression screws. Other requirements may exist for attachment of lugs and accessories to these devices. See manufacturer data.

*Per ABB.com

† Littelfuse Device nameplate data.

‡ Panduit, “Torque Chart for Aluminum Mechanical Connectors”.

Section Overview

System overvoltage is a growing concern in the electrical industry. Component miniaturization has resulted in increased sensitivity to many devices. The majority of these devices are unable to handle high currents that result from Electrostatic Discharge (ESD) and other voltage transients. Littelfuse® offers a broad range of overvoltage protection to safeguard against these conditions.



SUPPRESSION PRODUCTS

Table of Contents

Industrial Varistor Products	163
LVSP Series Surge Suppression Fuses	165
BVSP Series Surge Protection Device	166

OVERVOLTAGE SUPPRESSION PRODUCTS

Varistors, Surge Fuses and Varistor Assemblies



What Are Transients?

Transients are short duration surges of electrical energy that result from the sudden release of previously stored energy. In terms of electrical and electronic circuits, this energy can be released through intentional, controlled switching action, or induced into a circuit from external sources. If the voltage magnitude of the transient is large enough, circuit component damage or malfunction of the circuit may result.

Transient Sources and Magnitude

	VOLTAGE	CURRENT	RISE-TIME	DURATION
Lightning	25 kV	20 kA	10 μ s	50 ms
Switching	600 V	500 A	50 μ s	500 ms
EMP	300 kV	10 A	20 ns	1 ms
ESD	15 kV	30 A	1-5 ns	100 ns

Transient Voltage Scenarios

The switching of inductive loads generates high energy transients that increase in magnitude with increasingly heavy loads. When the inductive load is switched off, the collapsing magnetic field is converted into electrical energy, which takes the form of a double exponential transient. Depending on the source, these transients can be as large as hundreds of volts and hundreds of amps with duration times of 400 milliseconds.

Typical sources of inductive transients are:

- Generators
- Motors
- Relays
- Transformers

These examples are extremely common in electrical and electronic systems. Because the sizes of the loads vary according to the application, the wave shape, duration, peak current, and peak voltage are all variables which exist in real world transients. Once these variables can be approximated, a suitable suppressor technology can be selected.

Overvoltage Applications

- Industrial, High Energy AC Products such as Solenoids, Motor Drives and Robotics
- Telecommunications Products
- UPS, AC Panels, Power Supplies, Circuit Breakers (TVSS Products)
- Portable and Automotive Electronic Equipment

Lightning Induced Transients

Transients induced by lightning are not the result of a direct strike. When a lightning strike occurs, the event creates a magnetic field which can induce transients of large magnitude in nearby electrical cables.

Technological Solutions for Transient Threats

Because of the various types of transients and applications, it is necessary to employ protection devices with different characteristics in different applications. Littelfuse offers the broadest range of circuit protection technologies.

Overvoltage Protection Portfolio Includes:

MOVs (Metal Oxide Varistors)

A ceramic technology that offers medium to very high energy ratings for a wide range of applications. Available in screw terminal, radial, square and axial leaded connections.

Discrete TVS Diode

This Silicon Avalanche Diode Technology is available in surface mount and axial leaded packages. It offers protection from medium to very high energy transients and can be used in wide range of applications.

OVERVOLTAGE SUPPRESSION PRODUCTS

Varistors, Surge Fuses and Varistor Assemblies



Radial Leaded MOV

SERIES NAME ¹	OPERATING AC VOLTAGE RANGE	OPERATING DC VOLTAGE RANGE	PEAK CURRENT RANGE ² (A)	PEAK ENERGY RANGE ³	OPERATING TEMPERATURE RANGE	MOUNT/FORM FACTOR	DISC SIZE	AGENCY					LEAD FREE
								UL	CSA	VDE	CECC	ROHS	
TMOV®/iTMOV®	115-750	—	6000-10,000	35-480	-55 to +85°C	Radial Leaded	14, 20, 34 mm	•	•	•	•	•	•
TMOV® 25S	115-750	—	20,000	170-670			25 mm	•				•	•
UltraMOV™	130-625	170-825	1750-10,000	12.5-720			7, 10, 14, 20, 25 mm	•	•	•	•	•	•
UltraMOV™ 25S	115-750	150-970	22,000	230-890			25 mm	•	•	•	•	•	•
C-III	130-660		3500-9000	40-530			10, 14, 20 mm	•	•	•	•	•	•
LA	130-1000	175-1200	1200-6500	11-360			7, 10, 14, 20 mm	•	•	•	•	•	•
ZA	4-460	5.5-615	50-6500	0.1-52			5, 7, 10, 14, 20 mm	•	•	•	•	•	•

Industrial High Energy Terminal MOV

SERIES NAME ¹	OPERATING AC VOLTAGE RANGE	OPERATING DC VOLTAGE RANGE	PEAK CURRENT RANGE ² (A)	PEAK ENERGY RANGE ³	OPERATING TEMPERATURE RANGE	MOUNT/FORM FACTOR	DISC SIZE	AGENCY			LEAD FREE
								UL	CSA	ROHS	
BA/BB	130-2800	175-3500	50,000 70,000	450-10,000	-55 to +85°C	Screw / Clip Terminals	60 mm	•		•	
DA/DB	130-750	175-970	40,000	270-1050			40 mm	•		•	•
HA	130-750	175-970	25,000 40,000	200-1050			32, 40 mm	•	•	•	•
TMOV34S®	115-750	—	40,000	235-1050		Industrial Packaged Radial Leads	34 mm	•		•	•
HB34, HG34, HF34	130-750	175-970	40,000	270-1050			34 mm	•	•	•	•
DHB34	250-2800	330-3500	20,000 70,000	330-10,000			34 mm			•	
CA	250-2800	330-3500	20,000 70,000	330-10,000		Bare Disc	60 mm			•	

High Power TVS Diodes

SERIES NAME ¹	PACKAGE TYPE	REVERSE STANDOFF VOLTAGE (V _R)	PEAK PULSE POWER RANGE ¹ (P _{PP})	PEAK PULSE CURRENT (I _{PP} 8x20µs)	OPERATING TEMPERATURE	HALOGEN FREE	ROHS COMPLIANT
15KPA	P600	17-280	15,000 W		-85° to +302° F (-55° to +175° C)	•	•
20KPA	P600	20.0-300	20,000 W	Not Applicable		•	•
30KPA	P600	28.0-288	30,000 W			•	•
AK6	Radial Lead	58-430	NA	6,000 A	-67° to +347° F (-55° to +150° C)	•	•
AK10	Radial Lead	58-430	NA	10,000 A		•	•

1. Detailed information about most product series listed here can be found on littelfuse.com/varistor
 2. Not an applicable parameter for Crowbar devices
 3. Value shown in Joules

LVSP SURGE SUPPRESSION FUSE

600 Vac • 5-100 kA



Description

The Littelfuse® Varistor Protection (LVSP) Fuses are intended for the protection of TVSS products. The LVSP series has been designed to survive the 8 x 20 μs lightning surges described in various standards (UL 1449, IEC 61000-4-5 and IEEE C62.41) without opening. This allows the TVSS to perform the necessary suppression. The LVSP is not rated for continuous current and the ratings are specific 8 x 20 μs surge capability. The LVSP series can be used to facilitate TVSS module compliance to UL 1449 in permanently connected applications (abnormal overvoltage, unlimited current conditions).

Features/Benefits

- Very current limiting under AC short-circuit conditions
- Available in multiple mounting configurations (cartridge, bolt-in, PC board mount)
- Provides short circuit protection in TVSS systems and complements the Littelfuse line of overvoltage products (HA, HB34, TMOV® and iTMOV® varistors as well as the AK-10 series TVS diodes)

Applications

- TVSS products
- Surge arrestors

Recommended Fuse Blocks

LVSP (5-20)-2	
L60030M (open block).....	107
LPSM (dead front)	117
LVSP (30-80)-2	
LFJ60030 (open block).....	91
LFPSJ30 (dead front).....	118
LVSP (100)	
LFJ60100 (open block).....	91

Web Resources

Download other technical information:
littelfuse.com/lvsp

Specifications

Voltage Rating	600 Vac
Interrupting Rating	200 kA
Ratings	5 – 100 kA 8 x 20 μs surge withstand
Approvals	UL Recognized (File: E71611)
Environmental	RoHs Compliant

Electrical Specifications

CATALOG NUMBER	8 X 20 μS SURGE RATING	NOMINAL MELTING I ² T (A ² S)	NOMINAL CLEARING I ² T (A ² S)	I _{peak} @100 kA 60 HZ (A)
LVSP5	5,000	359	981	3,700
LVSP10	10,000	1,300	3,210	5,823
LVSP15	15,000	3,267	6,235	7,765
LVSP20	20,000	4,940	11,710	8,135
LVSP30	30,000	11,950	35,325	12,478
LVSP40	40,000	20,550	61,700	15,250
LVSP60	60,000	39,240	145,555	19,604
LVSP80	80,000	75,000	254,000	24,600
LVSP100	100,000	Contact Factory		

Ordering Information

SURGE RATING	CATALOG/ORDERING NUMBER					
	CARTRIDGE		LEADED		BOLT-IN	
5	LVSP52	LVSP0005TX2	LVSP5R	LVSP0005TXR	–	–
10	LVSP102	LVSP0010TX2	LVSP10R	LVSP0010TXR	–	–
15	LVSP152	LVSP0015TX2	LVSP15R	LVSP0015TXR	–	–
20	LVSP202	LVSP0020TX2	LVSP20R	LVSP0020TXR	–	–
30	LVSP302	LVSP0030TX2	–	–	LVSP30	LVSP0030T
40	LVSP402	LVSP0040TX2	–	–	LVSP40	LVSP0040T
60	LVSP60-2	LVSP0060TX2	–	–	LVSP60	LVSP0060T
80	LVSP802	LVSP0080TX2	–	–	LVSP80	LVSP0080T
100	–	–	–	–	LVSP100-L	LVSP0100VXL

Dimensions Inches (mm)

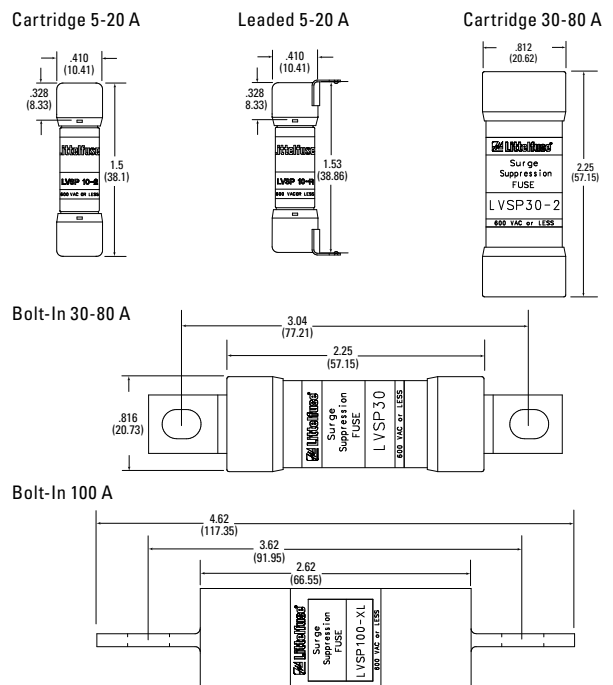

BVSP SERIES SURGE PROTECTION DEVICE

600 Vac • 10 kA



Specifications

Voltage Rating	600 Vac
Interrupting Rating	200 kA
Ratings	10 kA 8 x 20 μ s surge withstand

Ordering Information

SERIES	8 X 20 μ S SURGE RATING (A)	PACKAGE QUANTITY	MOUNTING METHOD	CATALOG NUMBER	ORDERING NUMBER
BVSP	10,000	10	Ferrule	BVSP10-2	BVSP0010TX2
BVSP	10,000	10	PCB Tabs	BVSP10-R	BVSP0010TXR

Description

The Littelfuse® BVSP surge protection device (SPD) is intended for the protection of transient voltage surge suppressions (TVSS) systems. The BVSP series has been designed to survive the 8 x 20 μ s lightning surges described in various standards (UL 1449, IEC 61000-4-5 and IEEE C62.41) without opening. This allows the TVSS to perform the necessary suppression. The BVSP is not rated for continuous current and the ratings are specific 8 x 20 μ s surge capability. The BVSP series can be used to facilitate TVSS module compliance to UL 1449 in permanently connected applications (abnormal overvoltage, unlimited current conditions).

Features/Benefits

- Very current limiting under AC short-circuit conditions
- Available in ferrule and printed circuit board (PCB) configurations
- Provides short circuit protection in TVSS systems and complements the Littelfuse line of overvoltage products (HA, HB34, TMOV® and iTMOV® varistors as well as the AK-10 series TVS diodes)

Applications

- TVSS products
- Surge arrestors

Recommended Fuse Holders

L60030M (open block).....	107
LPSM (dead front)	117

Electrical Specifications

CATALOG NUMBER	8 X 20 μ S SURGE RATING (A)	NOMINAL MELTING I ² T (A ² S)	NOMINAL CLEARING I ² T (A ² S)	I _{peak} @ 200 kA 60 HZ (A)
BVSP10-2	10,000	1,580	9,960	8,160
BVSP10-R	10,000	1,580	9,960	8,160

Dimensions Inches (mm)

Ferrule Version

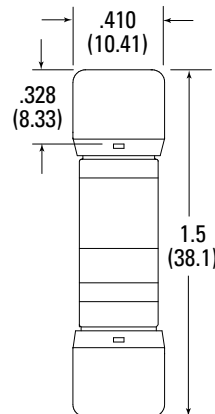

PCB Version

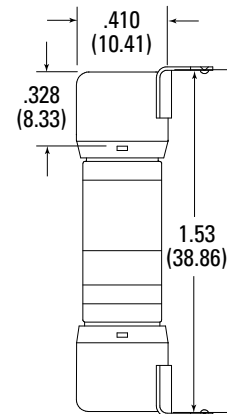

Section Overview

Miscellaneous Accessories include custom-built solutions designed specifically to meet code requirements, fuse reducers, box cover units and an assortment of useful fuse and holder accessories.



MISCELLANEOUS PRODUCTS

Table of Contents

Fuse Reducers	166
Box Cover Units	167
Fuse Replacement & Custom Kits	168
Electronic Fuse Display & Spare Fuse Cabinet.....	169

FUSE REDUCERS



Ordering Information

250 Volt

CATALOG/ORDERING NUMBER		FUSE CLIP	FUSE CASE SIZE
CLASS H/K5	CLASS R		
LRU 263	LRU 263 R	60 A	30 A
LRU 213	LRU 213 R	100 A	30 A
LRU 216	LRU 216 R	100 A	60 A
LRU 226	LRU 226 R	200 A	60 A
LRU 2621	LRU 2621 R	200 A	100 A
LRU 2641	LRU 2641 R	400 A	100 A
LRU 2642	LRU 2642 R	400 A	200 A
LRU 2661	LRU 2661 R	600 A	100 A
LRU 2662	LRU 2662 R	600 A	200 A
LRU 2664	LRU 2664 R*	600 A	400 A

*Only one reducer required.

600 Volt

CATALOG / ORDERING NUMBER			FUSE CLIP	FUSE CASE SIZE
CLASS H/K5	CLASS R	CLASS J		
LRU 663	LRU 663 R	LRUJ63	60 A	30 A
LRU 216	LRU 216 R	LRUJ13	100 A	30 A
LRU 616	LRU 616 R	LRUJ16†	100 A	60 A
LRU 626	LRU 626 R	LRUJ26	200 A	60 A
LRU 2621	LRU 2621 R	LRUJ21	200 A	100 A
LRU 2641	LRU 2641 R	LRUJ41	400 A	100 A
LRU 2642	LRU 2642 R	LRUJ42	400 A	200 A
LRU 2661	LRU 2661 R	—	600 A	100 A
LRU 2662	LRU 2662 R	—	600 A	200 A
LRU 2664	LRU 2664 R†	LRUJ64	600 A	400 A

†Only one reducer required.

‡Fuse and reducer combination is slightly larger in diameter than 100 A Class J fuses. For specific applications, contact factory.
Class J reducers cannot be used in bolt-on applications.

Description

Littelfuse® fuse reducers allow smaller size fuses to be installed into existing fuse clips to prevent overfusing.

Features/Benefits

- Simple installation
- Reduces inventory requirements
- Silver brazed joints for maximum strength
- UL Listed (File: E136855)
- CSA Certified (File: LR92899)

Web Resources

Download technical information: littelfuse.com/lruh
littelfuse.com/lrur
littelfuse.com/lruj

Dimensions

Refer to the fuse section of this catalog for fuse dimensions.

Recommended Fuses

Class H/K5 Fuse Reducers

NLN / NLS..... 20

Class R Fuse Reducers

FLNR / FLSR..... 17
FLNR_ID / FLSR_ID 17
IDSR 16
LLNRK / LLSRK..... 13
LLSRK_ID 13
KLNR / KLSR..... 15

Class J Fuse Reducers

JTD_ID / JTD 21
JLS 22

BOX COVER UNITS



Description

Provide economical method of protecting small motors against overcurrent damage.

Applications

- Edison-Base plug fuses (TOO, TLO)
- Type S plug fuses (SOO, SLO) with adapters (SAO)

Specifications

Voltage Rating 125 V
Max Ampere Rating 15 A
Approvals UL Listed parts (Except LSSY-RL)

Web Resources

Sample requests, downloadable CAD drawings and other technical information: www.littelfuse.com/boxcover

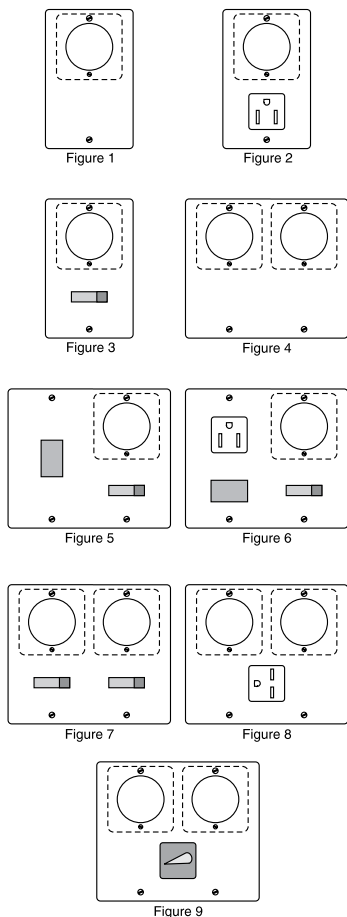

FIGURE NUMBER	LITTELFUSE PART NUMBER	BOX COVER FEATURES					TO BE MOUNTED ON
		EDISON BASE FUSE HOLDER	GROUNDING RECEPTACLE	SINGLE POLE SWITCH	TWO POLE SWITCH	PILOT LIGHT	
1	LSOU	1	—	—	—	—	2-1/4" Handy Box
	LSOW	1	—	—	—	—	2-3/4" Switch Box
	LSOX	1	—	—	—	—	4" Octagon Box
	LSOY	1	—	—	—	—	4" Square Box
2	LSRU*	1	1	—	—	—	2-1/4" Handy Box
	LSRW	1	1	—	—	—	2-3/4" Switch Box
	LSRY	1	1	—	—	—	4" Square Box
3	LSSU*	1	—	1	—	—	2-1/4" Handy Box
	LSSW	1	—	1	—	—	2-3/4" Switch Box
	LSSX	1	—	1	—	—	4" Octagon Box
	LSSY*	1	—	1	—	—	4" Square Box
4	LSOY-B	2	—	—	—	—	4" Square Box
5	LSSY-L	1	—	1	—	1	4" Square Box
6	LSSY-RL	1	1	1	—	1	4" Square Box
7	LSCY	2	—	2	—	—	4" Square Box
8	LSKA	2	1 (250V)	—	—	—	4-11/16" Square Box
9	LSTY	2	—	—	1	—	4" Square Box

*UL Listed (File No. E308725)

FRCK SERIES FUSE REPLACEMENT & CUSTOM KITS



Description

Fuse Replacement and Custom Kits help reduce downtime by providing mobile storage and organization for replacement fuses. The FRCK Series provides a custom solution that can be filled with multiple fuse series that are more common or specific to your needs or application.

Features/Benefits

- Custom sized compartments fit various fuse series
- Large kit features a convenient handle for carrying
- Kits are sold empty for complete customization
- Each kit comes with a blank label on the inside cover so users can write in part numbers or use bar code labels to help with refills.

Web Resources

Additional information: littelfuse.com/kits

Ordering Information

KIT SIZE	DIMENSIONS L X W X H (INCHES)	DESCRIPTION	CATALOG NUMBER
Large	16.00 x 12.00 x 10.00	Mobile organizer with 2 small and 3 medium drawers; Unique FRACK Label for Oil & Gas	FRCK-OG
Large	16.00 x 12.00 x 10.00	Mobile organizer with 2 small and 3 medium drawers	FRCK-LG
Medium	14.00 x 9.13 x 2.00	14" organizer with adjustable dividers	FRCK-MD
Small	8.25 x 4.25 x 1.00	8" organizer with up to 6 compartments	FRCK-SM



FRCK-OG & FRCK-LG



FRCK-MD



FRCK-SM

FUSE DISPLAYS AND CABINETS

Electronic Fuse Display



Description

This wall-mountable or free-standing modular rack system prominently displays Littelfuse glass and automotive fuses. Additional sections can be quickly snapped on for a larger product selection. Each rack features a cross reference guide to help customers locate the proper replacement fuse.

Features/Benefits

- Holds 720 (144 5-packs) of the most popular glass, ceramic, and automotive fuses
- Designed to save space—measures 14" H x 9" W x 4" D Suitable for wall or counter mounting
- Includes cross reference, product identification guide, and back-up card for easy reordering
- Expandable with modular section that can hold 240 fuses (48 5-packs) per section

Fully stocked rack includes the following parts

3AG (GLASS) FAST ACTING FUSES		3AG (GLASS) SLO-BLO® FUSES	
QUANTITY	CATALOG NUMBER	QUANTITY	CATALOG NUMBER
25	312 1/2A	25	313 1/2A
50	312 1A	25	313 3/4A
25	312 1 1/2A	25	313 1A
75	312 2A	25	313 1 1/2A
25	312 2 1/2A	50	313 2A
75	312 3A	25	313 2 1/2A
25	312 4A	25	313 3A
25	312 5A	25	313 4A
25	312 10A	25	313 5A

3AB (CERAMIC) NORMAL-BLO FUSES		3AB (CERAMIC) SLO-BLO® FUSES	
QUANTITY	CATALOG NUMBER	QUANTITY	CATALOG NUMBER
25	314 15A	25	326 8A
25	314 20A	20	326 10A
25	314 30A	—	—

Ordering Information

TYPE	CATALOG NUMBER	ORDERING NUMBER
Fully Stocked Display	094324PG	00940324ZXPG
Empty Display Rack	FDR001PG	0FDR0001ZXPG
Additional Sections	MRS001PG	0MRS0001ZXPG

Spare Fuse Cabinet



Description

- Steel cabinet with piano hinges that can be locked to prevent unauthorized access. Weather stripped to reduce the accumulation of dust, dirt and moisture
- Convenient inventory card located inside door. Measures 30" H x 24" W x 12" D. Keyhole mounting holes 16" on center for easy installation

Ordering Information

TYPE	CATALOG NUMBER	ORDERING NUMBER
Spare Fuse Cabinet	LSFC	LSFC
Spare Keys	LKEY001	LKEY0001Z

Web Resources

Additional information: littelfuse.com/lscf

Section Overview

This Technical Application Guide or 'Fuseology' section provides the information needed to select the correct types of Littelfuse POWR-GARD® fuses for most applications. If there are any questions or if additional data is needed for a specific use, call the Littelfuse Technical Support and Engineering Service Group at **1-800-TEC-FUSE** (1-800-832-3873), email them at **techline@littelfuse.com** or visit us at **littelfuse.com**.



TECHNICAL APPLICATION GUIDE

Table of Contents



Technical Information

White papers, and a library of technical information is available online at

littelfuse.com/technicalcenter

Fuseology Fundamentals.....	173
Selection Considerations.....	174
Time-current Curves and Peak Let-through Charts.....	179
Selective Coordination.....	181
UL/CSA Fuse Classes and Applications.....	184
Terms and Definitions.....	186
Motor Protection Tables.....	193
Condensed Fuse Cross Reference.....	196
Alphanumeric Index of Catalog Numbers.....	197

FUSEOLOGY FUNDAMENTALS

I. OVERCURRENT PROTECTION FUNDAMENTALS (FUSES AND HOW THEY WORK)

Introduction

An important part of developing quality overcurrent protection is an understanding of system needs and overcurrent protective device fundamentals. This section discusses these topics with special attention to the application of fuses. If you have additional questions, call our Technical Support Group at 1-800-TEC-FUSE (1-800-832-3873). Definitions of terms used in this section are located towards the end of this Technical Application Guide.

Why Overcurrent Protection?

All electrical systems eventually experience overcurrents. Unless removed in time, even moderate overcurrents quickly overheat system components, damaging insulation, conductors, and equipment. Large overcurrents may melt conductors and vaporize insulation. Very high currents produce magnetic forces that bend and twist bus bars. These high currents can pull cables from their terminals and crack insulators and spacers.

Too frequently, fires, explosions, poisonous fumes and panic accompany uncontrolled overcurrents. This not only damages electrical systems and equipment, but may cause injury or death to personnel nearby.

To reduce these hazards, the National Electrical Code® (NEC®), OSHA regulations, and other applicable design and installation standards require overcurrent protection that will disconnect overloaded or faulted equipment.

Industry and governmental organizations have developed performance standards for overcurrent devices and testing procedures that show compliance with the standards and with the NEC. These organizations include: the American National Standards Institute (ANSI), National Electrical Manufacturers Association (NEMA), and the National Fire Protection Association (NFPA), all of which work in conjunction with Nationally Recognized Testing Laboratories (NRTL) such as Underwriters Laboratories (UL).

Electrical systems must meet applicable code requirements including those for overcurrent protection before electric utilities are allowed to provide electric power to a facility.

What is Quality Overcurrent Protection?

A system with quality overcurrent protection has the following characteristics:

1. Meets all legal requirements, such as NEC®, OSHA, local codes, etc.
2. Provides maximum safety for personnel, exceeding minimum code requirements as necessary.
3. Minimizes overcurrent damage to property, equipment, and electrical systems.
4. Provides coordinated protection. Only the protective device immediately on the line side of an overcurrent opens to protect the system and minimize unnecessary downtime.
5. Is cost effective while providing reserve interrupting capacity for future growth.
6. Consists of equipment and components not subject to obsolescence and requiring only minimum maintenance that can be performed by regular maintenance personnel using readily available tools and equipment.

Overcurrent Types and Effects

An overcurrent is any current that exceeds the ampere rating of conductors, equipment, or devices under conditions of use. The term "overcurrent" includes both overloads and short-circuits.

Overloads

An overload is an overcurrent confined to normal current paths in which there is no insulation breakdown.

Sustained overloads are commonly caused by installing excessive equipment such as additional lighting fixtures or too many motors. Sustained overloads are also caused by overloading mechanical equipment and by equipment breakdown such as failed bearings. If not disconnected within established time limits, sustained overloads eventually overheat circuit components causing thermal damage to insulation and other system components.

Overcurrent protective devices must disconnect circuits and equipment experiencing continuous or sustained overloads before overheating occurs. Even moderate insulation overheating can seriously reduce the life of the components and/or equipment involved. For example, motors overloaded by just 15% may experience less than 50% of normal insulation life.

Temporary overloads occur frequently. Common causes include temporary equipment overloads such as a machine tool taking too deep of a cut, or simply the starting of an inductive load such as a motor. Since temporary overloads are by definition harmless, overcurrent protective devices should not open or clear the circuit.

It is important to realize that fuses selected must have sufficient time-delay to allow motors to start and temporary overloads to subside. However, should the overcurrent continue, fuses must then open before system components are damaged. Littelfuse POWR-PRO® and POWR-GARD® time-delay fuses are designed to meet these types of protective needs. In general, time-delay fuses hold 500% of the rated current for a minimum of ten seconds, yet will still open quickly on higher values of current.

FUSEOLOGY FUNDAMENTALS

Even though government-mandated high-efficiency motors and NEMA Design E motors have much higher locked rotor currents, POWR-PRO® time-delay fuses such as the FLSR_ID, LLSRK_ID, or IDSR series have sufficient time-delay to permit motors to start when the fuses are properly selected in accordance with the NEC®.

Short-Circuits

A short-circuit is an overcurrent flowing outside of its normal path. Types of short-circuits are generally divided into three categories: bolted faults, arcing faults, and ground faults. Each type of short-circuit is defined in the Terms and Definitions section.

A short-circuit is caused by an insulation breakdown or faulty connection. During a circuit's normal operation, the connected load determines current. When a short-circuit occurs, the current bypasses the normal load and takes a "shorter path," hence the term 'short-circuit'. Since there is no load impedance, the only factor limiting current flow is the total distribution system's impedance from the utility's generators to the point of fault.

A typical electrical system might have a normal load impedance of 10 ohms. But in a single-phase situation, the same system might have a load impedance of 0.005 ohms or less. In order to compare the two scenarios, it is best to apply Ohm's Law ($I = E/R$ for AC systems). A 480 volt single-phase circuit with the 10 ohm load impedance would draw 48 amperes ($480/10 = 48$). If the same circuit has a 0.005 ohm system impedance when the load is shorted, the available fault current would increase significantly to 96,000 amperes ($480/0.005 = 96,000$).

As stated, short-circuits are currents that flow outside of their normal path. Regardless of the magnitude of overcurrent, the excessive current must be removed quickly. If not removed promptly, the large currents associated with short-circuits may have three profound effects on an electrical system: heating, magnetic stress, and arcing.

Heating occurs in every part of an electrical system when current passes through the system. When overcurrents are large enough, heating is practically instantaneous. The energy in such overcurrents is measured in ampere-squared seconds (I^2t). An overcurrent of 10,000 amperes that lasts for 0.01 seconds has an I^2t of 1,000,000 A^2s . If the current could be reduced from 10,000 amperes to 1,000 amperes for the same period of time, the corresponding I^2t would be reduced to 10,000 A^2s , or just one percent of the original value.

If the current in a conductor increases 10 times, the I^2t increases 100 times. A current of only 7,500 amperes can melt a #8 AWG copper wire in 0.1 second. Within eight milliseconds (0.008 seconds or one-half cycle), a current of 6,500 amperes can raise the temperature of #12 AWG THHN thermoplastic insulated copper wire from its operating temperature of 75°C to its maximum short-circuit

temperature of 150°C. Any currents larger than this may immediately vaporize organic insulations. Arcs at the point of fault or from mechanical switching such as automatic transfer switches or circuit breakers may ignite the vapors causing violent explosions and electrical flash.

Magnetic stress (or force) is a function of the peak current squared. Fault currents of 100,000 amperes can exert forces of more than 7,000 lb. per foot of bus bar. Stresses of this magnitude may damage insulation, pull conductors from terminals, and stress equipment terminals sufficiently such that significant damage occurs.

Arcing at the point of fault melts and vaporizes all of the conductors and components involved in the fault. The arcs often burn through raceways and equipment enclosures, showering the area with molten metal that quickly starts fires and/or injures any personnel in the area. Additional short-circuits are often created when vaporized material is deposited on insulators and other surfaces. Sustained arcing-faults vaporize organic insulation, and the vapors may explode or burn.

Whether the effects are heating, magnetic stress, and/or arcing, the potential damage to electrical systems can be significant as a result of short-circuits occurring.

II. SELECTION CONSIDERATIONS

Selection Considerations for Fuses (600 volts and below)

Since overcurrent protection is crucial to reliable electrical system operation and safety, overcurrent device selection and application should be carefully considered. When selecting fuses, the following parameters or considerations need to be evaluated:

- Current Rating
- Voltage Rating
- Interrupting Rating
- Type of Protection and Fuse Characteristics
- Current Limitation
- Physical Size
- Indication

Current Rating

The current rating of a fuse is the AC or DC current, expressed in amperes, which the fuse is capable of carrying continuously under specified conditions. Fuses selected for a circuit must have ampere ratings that meet NEC® requirements, namely those found in NEC® Articles 240 and 430. These NEC® requirements establish maximum ratings and in some cases, minimum ratings. When selecting a fuse, it is generally recommended to select a current rating as close as possible to the system's normal running current.

SELECTION CONSIDERATIONS

Voltage Rating

The voltage rating of a fuse is the maximum AC or DC voltage at which the fuse is designed to operate. Fuse voltage ratings must equal or exceed the circuit voltage where the fuses will be installed, and fuses used in DC circuits must be specifically rated for DC applications. In terms of voltage, fuses may be rated for AC only, DC only, or both AC and DC. However, exceeding the voltage ratings or using an AC only fuse in a DC circuit could result in violent destruction of the fuse.

The standard 600 volt rated fuses discussed in this section may be applied at any voltage less than or equal to their rating. For example, a 600 volt fuse may be used in a 277 volt or even a 32 volt system, but not any system exceeding 600 volts.

NOTE: This does not apply to semiconductor fuses and medium voltage fuses. See the semiconductor and medium voltage fuse application information on littelfuse.com for voltage limitations of these fuses.

Interrupting Rating

The interrupting rating of a fuse is the highest available symmetrical rms alternating current that the fuse is required to safely interrupt at its rated voltage under standardized test conditions. A fuse must interrupt all overcurrents up to its interrupting rating without experiencing damage. Standard UL fuses are available with interrupting ratings of 10,000 A, 50,000 A, 100,000 A, 200,000 A, and 300,000 A.

NEC® Article 110.9 requires that all equipment intended to break current at fault levels have an interrupting rating sufficient for the system voltage and current available at the equipment's line terminals. Refer to *Figure 1*. It is vitally important to select fuses with interrupting ratings which equal or exceed the available fault current.

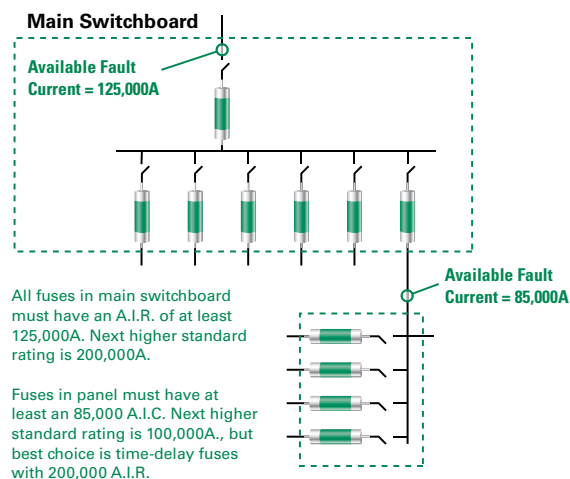

Figure 1 – Interrupting Rating Requirements per NEC

The recommendation to standardize on fuses with at least a 200,000 ampere interrupting rating (AIR) ensures that all fuses have an adequate interrupting rating while providing reserve interrupting capacity for future increases in available fault current.

300,000 AIR Fuses

Littelfuse POWR-PRO® fuse series have a Littelfuse Self-Certified interrupting rating of 300,000 amperes rms symmetrical. The 300,000 ampere testing was performed in a Nationally Recognized Testing Laboratory, and the tests were UL witnessed. UL has ruled that fuses with a UL interrupting rating greater than 200,000 amperes must be marked as “Special Purpose Fuses” and may not be labeled as UL Listed Class RK5, RK1, L, etc.

Type of Protection and Fuse Characteristics

Time current characteristics determine how fast a fuse responds to overcurrents. All fuses have inverse time characteristics; that is, the fuse opening time decreases as the magnitude of overcurrent increases. When properly rated in accordance with NEC® requirements, fuses provide both overload and short-circuit protection to system conductors and components. However, in some instances such as when fuses are used to backup circuit breakers or to provide motor branch circuit short-circuit and ground fault protection, fuses provide only short-circuit protection. A fuse's response to overcurrents is divided into short-circuits and overloads.

Short-Circuits

A fuse's short-circuit response is its opening time on higher-value currents. For power fuses, higher-value currents are generally over 500-600% of the fuse's current rating. As stated earlier, all fuses have inverse time characteristics: the higher the current, the faster the opening time. Since short-circuits should be removed quickly, inverse time is especially important for short-circuit protection.

Overloads

While fuses must disconnect overloaded conductors and equipment before the conductors and components are seriously overheated, they should not disconnect harmless temporary overloads. To provide sufficient overload protection for system conductors, UL has established maximum fuse opening times at 135% and 200% of a fuse's current rating. All UL Listed fuses for application in accordance with the National Electrical Code® must meet these limits whether they are fast-acting or time-delay fuses.

As just stated, a fuse is designed to respond to two types of overcurrents – short circuits and overloads. As a result, selecting the proper fuse for a given application usually involves deciding whether to use a time-delay fuse or a fast-acting fuse. A more in-depth review of both possible scenarios is important at this time.

SELECTION CONSIDERATIONS

Fast-Acting (Normal-Opening) Fuses

Fast-acting fuses (sometimes called “Normal-opening” fuses) have no intentional time-delay. Typical opening times at 500% of the fuse ampere rating range from 0.05 second to approximately 2 seconds. Fast-Acting fuses are suitable for non-inductive loads such as incandescent lighting and general-purpose feeders, or branch circuits with little or no motor load. When protecting motors and other inductive loads, fast-acting fuses must be rated at 200-300% of load currents to prevent nuisance opening on in-rush currents. Fuses with such increased ratings no longer furnish adequate protection from overloads and only provide short-circuit protection. Overload relays or other overload protection devices must be provided to properly protect conductors and equipment from overload conditions.

All fast-acting fuses provide fast short-circuit response within their interrupting rating. Some are considered current-limiting, such as UL Class T and Class J. Others are non-current-limiting, such as UL Class H.

Time-Delay (SLO-BLO®) Fuses

Most UL Class CC, CD, G, J, L, RK5 and RK1 fuses, plus some of the UL Listed Miscellaneous fuses are considered time-delay. If so, they are identified as such on the fuse label with the words “Time-Delay”, “TD”, “D”, or some other suitable marking. Minimum time-delay varies with the fuse class, and to some degree with the fuse ampere rating. UL standards for POWR-GARD® fuse series FLNR, FLNR_ID, FLSR, FLSR_ID, IDSR (UL Class RK5), LLNRK, LLSRK, LLSRK_ID (UL Class RK1), and JTD, JTD_ID (UL Class J) require these fuses to carry 500% rated current for a minimum of 10 seconds. Standards for CCMR and KLDR (UL Class CC and CD) and SLC (UL Class G) fuses require them to carry 200% rated current for a minimum of 12 seconds.

Although there is no UL Classification for time-delay Class L fuses, it is still permissible for them to be marked “Time-Delay.” The amount of time-delay is determined by the manufacturer. Littelfuse KLPC series and KLLU series fuses will hold 500% current for 10 seconds or more.

In addition to providing time-delay for surges and short time overloads, time-delay fuses meet all UL requirements for sustained overload protection. On higher values of current, time-delay fuses are current-limiting; meaning they remove large overcurrents in less than one-half cycle (0.00833 seconds). Time-delay fuses provide the best overall protection for both motor and general purpose circuits, and eliminate nuisance fuse opening and most situations of downtime.

Compared to fast-acting fuses, time-delay fuses can be selected with ratings much closer to a circuit’s operating current. For example, on most motor circuits Class RK5 and RK1 fuses can be rated at 125-150% of a motor’s full load current (FLA). This provides superior overload and short-

circuit protection, and often permits the use of smaller, less expensive disconnect switches. Time-delay fuses have gradually replaced most one-time (UL Class K5) and renewable (UL Class H) fuses. Today, more than 50% of all fuses sold by electrical distributors are time-delay fuses.

Dual Element Fuses

Littelfuse time-delay FLNR, FLNR_ID, FLSR, FLSR_ID, IDSR (UL Class RK5), and LLNRK, LLSRK, LLSRK_ID (UL Class RK1), and some JTD, JTD_ID (UL Class J) series fuses have true dual-element construction meaning the fuse has an internal construction consisting of separate short-circuit and overload sections or elements. Time-delay elements are used for overload protection, and separate fast acting fuse elements or links are used to provide current-limiting short-circuit protection.

Very Fast-Acting Fuses

This category of fuses exists for limited applications. The principle use of very fast acting fuses is to protect solid-state electronic components, such as semiconductors. Fuse series designated as ‘High-Speed (Semiconductor) Fuses’ have special characteristics including quick overload response, very low I^2t and I_{peak} currents, and peak transient voltages, that provide protection for components that cannot withstand line surges, low value overloads, or short-circuit currents. Very fast-acting fuses are designed for very fast response to overloads and short-circuits, and are very current-limiting.

Effect of Ambient Temperature on Fuses

The current carrying capacity of fuses is 110% of the fuse rating when installed in a standard UL test circuit and tested in open air at 25°C ambient. This allows for derating to 100% of rating in an enclosure at 40°C ambient.

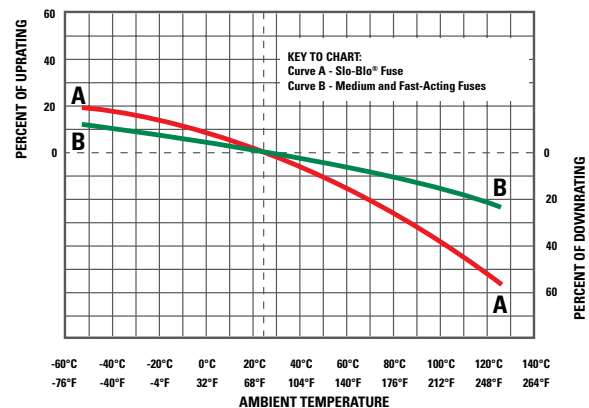

Figure 2 – Fuse Rerating Curve

SELECTION CONSIDERATIONS

Current Limitation

A current-limiting fuse is one that opens and clears a fault in less than 180 electrical degrees, or in other words, within the first half electrical cycle (0.00833 seconds). See the definition of Current-limiting Fuse and *Figure 13* in the Terms and Definitions section.

NEC® Article 240.2 states that a current-limiting overcurrent protective device must reduce the peak let-through current to a value substantially less than the potential peak current that would have occurred if the fuse were not used in the circuit or were replaced with solid conductors of the same impedance. The total destructive heat energy (I^2t) to the circuit and its components is greatly minimized as a result of using current-limiting fuses.

It is important to note that UL Class H 'Renewable' fuses designed decades ago are considered non-current limiting. Other than Midget fuses, almost all other fuse types used in today's electrical systems and applications are considered current-limiting per the above parameters. This selection consideration now involves determining the degree or level of current limitation required to properly protect a given device or system.

It is also important to point out that matching fuse holders and/or fuse blocks must reject non-current-limiting fuses and accept only current-limiting fuses of the stated UL Class.

Physical Size

While often overlooked, the physical size or overall dimensions of the fuse to be used in a given application is another important selection consideration to evaluate. There is a trend toward reduction of size in almost everything, and electrical equipment is no exception. Fuse size is actually determined by the size and dimensions of the fuse block or disconnect switch in which it is installed.

While saving space may be an important factor when selecting the proper fuses, other considerations should not be overlooked. Some of these include:

- Does the smallest fuse have the most desirable characteristics for the application?
- Does the equipment in which the fuse will be installed provide adequate space for maintenance?
- Do smaller fuses coordinate well with the system's other overcurrent protection?

If looking at just physical dimensions, a 600 volt, 60 ampere, 200,000 AIR, time-delay, dual-element UL Class CD fuse is smaller than a similarly rated UL Class J fuse, which is in turn, considerably smaller than a similarly rated UL Class RK1 or Class RK5 fuse. However, smaller-sized fuses can sometimes have less time-delay or more nuisance openings than their larger counterparts, so it is always important to consider all factors involved.

Indication

The newest consideration for selecting the best fuse for a given application is indication. Many of the more commonly used UL fuse classes are now available in both indicating and non-indicating versions. Built-in, blown-fuse indication that quickly identifies which fuse or fuses within an electrical panel or system have blown can be found on the Littelfuse POWR-PRO® LLSRK_ID Class RK1, FLNR_ID, FLSR_ID and IDSR Class RK5, and JTD_ID Class J fuse series.

The indicating feature on these fuses provides reduced downtime, increased safety, and reduced housekeeping or troubleshooting headaches and delays. Littelfuse Indicator® fuses will help lower the costs associated with downtime, provide longer fuse life by minimizing nuisance openings, increase system performance by minimizing equipment damage, and improve safety by minimizing accidents.

III. GENERAL FUSING RECOMMENDATIONS

Based on the above selection considerations, the following is recommended:

Fuses with ampere ratings from 1/10 through 600 amperes

- When available fault currents are less than 100,000 amperes and when equipment does not require the more current-limiting characteristics of UL Class RK1 fuses, FLNR and FLSR_ID Series Class RK5 current-limiting fuses provide superior time-delay and cycling characteristics at a lower cost than RK1 fuses. If available fault currents exceed 100,000 amperes, equipment may need the additional current-limitation capabilities of the LLNRK, LLSRK and LLSRK_ID series Class RK1 fuses.
- Fast-acting JLLN and JLLS series Class T fuses possess space-saving features that make them especially suitable for protection of molded case circuit breakers, meter banks, and similar limited-space applications.
- Time-delay JTD_ID and JTD series Class J fuses are used in OEM motor control center applications as well as other MRO motor and transformer applications requiring space-saving IEC Type 2 protection.
- Class CC and Class CD series fuses are used in control circuits and control panels where space is at a premium. The Littelfuse POWR-PRO CCMR series fuses are best used for protection of small motors, while the Littelfuse KLDR series fuses provide optimal protection for control power transformers and similar devices.

For questions about product applications, call our Technical Support Group at 800-TEC-FUSE.

SELECTION CONSIDERATIONS

Fuses with ampere ratings from 601 through 6,000 amperes

For superior protection of most general-purpose and motor circuits, it is recommended to use the POWR-PRO® KLPC series Class L fuses. The Class L fuses are the only time-delay fuse series available in these higher ampere ratings.

Information on all the Littelfuse fuse series referenced above can be found on the UL/CSA Fuse Classes and Applications Charts found later in this Technical Application Guide.

IV. SELECTION CONSIDERATIONS FOR FUSE HOLDERS

Equally important to the selection of the proper fuse is the correct selection of the proper fuse holder or fuse block for a given application. Fuse holders are available using most of the same Selection Considerations outlined above for UL fuse classes. Considerations for fuse holders include:

- Current Rating
- Voltage Rating
- Interrupting Rating
- Physical Size
- Indication

Additional selection considerations for fuse holders and fuse blocks include:

- Number of poles
- Mounting configuration
- Connector type

Number of Poles

The number of poles for each set of fuses is determined by the characteristics of the circuit. Most fuse block series are available in 1, 2, or 3 pole configurations, although some are also available with four or more poles. The option to gang individual fuse blocks into longer strips will be determined by the available space and type of wire being used.

Mounting Configuration

Depending on the fuse block design, another selection consideration to evaluate is how the fuse block is mounted or inserted into the panel. Historically, fuse blocks simply screwed into the back of the panel, but many newer designs have now added (or replaced the screw-in design with) a DIN rail mounting capability. The DIN rail mounting feature allows the blocks to be quickly installed and removed from the rails.

Connector Type

For Littelfuse fuse blocks, a choice of three connector types or wire terminations is available:

- Screw – for use with spade lugs or ring terminals.
- Screw with Pressure Plate – for use with solid or stranded wire without terminal and recommended for applications where vibration will be a factor.
- Box Lug – the most durable of the three options and used with all types of solid wire and Class B and Class C stranded wire.

There are a few additional aspects to keep in mind when selecting the fuse holder or fuse block needed for a given application. UL Class H blocks accept Class H, Class K5, and Class R fuses. Similarly, Midget-style fuse blocks accept both Midget and UL Class CC fuses.

Both UL Class R and Class CC fuse holders contain a rejection feature which prevents the insertion of a different Class or type of fuse. The physical size and dimensions of UL Class J and Class T fuses accomplish the same thing in preventing the insertion of a different Class of fuse as well.

V. CIRCUIT PROTECTION CHECKLIST

To select the proper overcurrent protective device for an electrical system, circuit and system designers should ask themselves the following questions before a system is designed:

- What is the normal or average current expected?
- What is the maximum continuous (three hours or more) current expected?
- What inrush or temporary surge currents can be expected?
- Are the overcurrent protective devices able to distinguish between expected inrush and surge currents, and open under sustained overloads and fault conditions?
- What kind of environmental extremes are possible? Dust, humidity, temperature extremes and other factors need to be considered.
- What is the maximum available fault current the protective device may have to interrupt?
- Is the overcurrent protective device rated for the system voltage?
- Will the overcurrent protective device provide the safest and most reliable protection for the specific equipment?
- Under short-circuit conditions, will the overcurrent protective device minimize the possibility of a fire or explosion?
- Does the overcurrent protective device meet all the applicable safety standards and installation requirements?

Answers to these questions and other criteria will help to determine the type overcurrent protection device to use for optimum safety, reliability and performance.

FUSE CHARACTERISTIC CURVES AND CHARTS

The performance capabilities of various fuses are graphically represented by two different types of fuse characteristic curves: time-current curves and peak let-through charts. These curves and charts define the operating characteristics of a given fuse, and assist system designers and engineers in selecting the proper fuse to protect equipment and electrical systems.

Understanding Time-current Curves

Time-current curves provide a graphical representation or plot of a fuse’s average melting (opening) time at any current. Time-current curves for Littelfuse POWR-GARD® fuses can be found online at littelfuse.com/technicalcenter.

In order to make the curves more readable, the performance information is presented on log-log paper. The overcurrent values appear across the bottom and increase in magnitude from left to right. Average melting times appear on the left-hand side of the curve and increase in magnitude from bottom to top. The ampere ratings of the individual fuses for a given series are listed at the top and increase in rating from left to right. *Figure 4* shows the average melting time curves for a typical time-delay fuse series.

As discussed earlier in the Fuseology Fundamentals section, time-delay, fast-acting, and very fast-acting fuses all respond differently based on the overcurrents occurring in the systems each is protecting. To illustrate the basic differences between each type of fuse, *Figure 5* compares the average melting times for 100 and 600 amp ratings

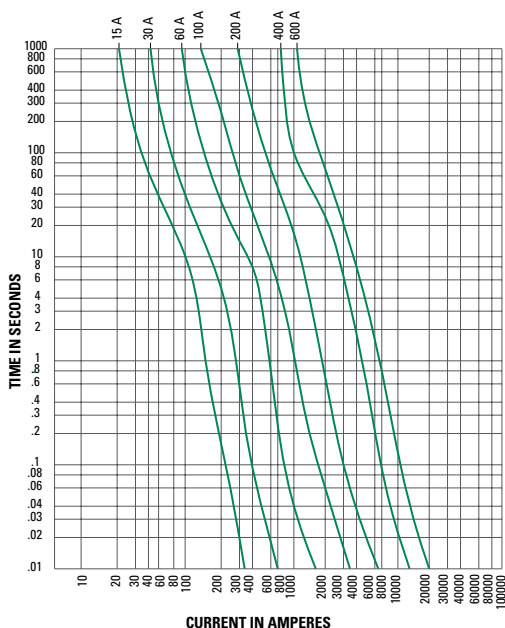

Figure 4 – Average Melting Time Curves for Typical Time-Delay Fuse Series

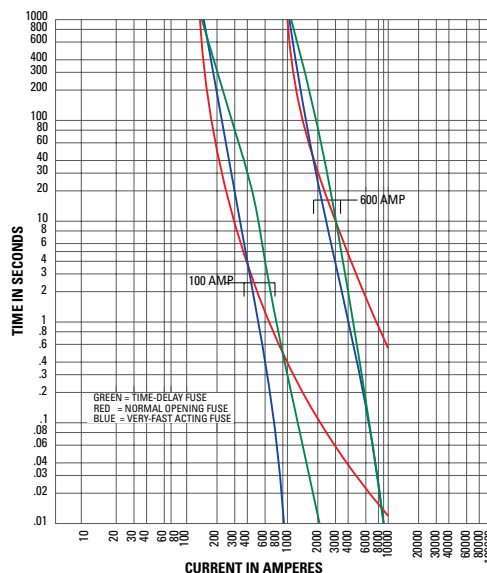

Figure 5 – Comparison of Average Melting Times for Three Fuse Types

of three fuse types: Littelfuse dual-element, time-delay LLSRK series class RK1 fuses (green); Littelfuse normal opening NLS series class K5 fuses (red); and Littelfuse very fast acting L60S series semiconductor fuses (blue).

To better illustrate this point, *Table 3* also compares the opening times for each of these fuses.

AMPERE RATING	FUSE TYPE	OPENING TIME IN SECONDS		
		500% RATING	800% RATING	1200% RATING
100	TIME-DELAY	12 secs.	0.9 secs.	0.14 secs.
	NORMAL OPENING	2 secs.	0.7 secs.	0.3 secs.
	VERY FAST-ACTING	1.3 secs.	0.02 secs.	>0.01 secs.
600	TIME-DELAY	14 secs.	0.7 secs.	0.045 secs.
	NORMAL OPENING	10 secs.	3 secs.	1.1 secs.
	VERY FAST-ACTING	2 secs.	0.05 secs.	>0.01 secs.

Table 3 – Comparative Opening Times for Time-Delay, Fast-Acting, and Very Fast-Acting Fuses

Peak Let-through Charts

Peak let-through charts illustrate the maximum instantaneous current through the fuse during the total clearing time. This represents the current limiting ability of a fuse.

Fuses that are current-limiting open severe short-circuits within the first half-cycle (180 electrical degrees or 0.00833 seconds) after the fault occurs. Current-limiting fuses also reduce the peak current of the available fault current to a value less than would occur without the fuse. This reduction is shown in *Figure 6*.

A fuse’s current-limiting effects are shown graphically on Peak Let-through charts such as the one shown in *Figure 7*. The values across the chart’s bottom represent the available

FUSE CHARACTERISTIC CURVES AND CHARTS

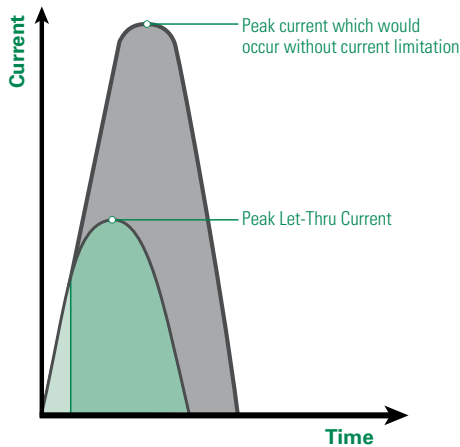

Figure 6 – Current limiting effect of fuses

(also referred to as potential or prospective) rms symmetrical fault current. The values on the chart's left side represent the instantaneous available peak current and the peak let-through current for various fuse ratings.

To better explain the function of these charts, let's run through an example. Start by entering the chart on the bottom at 100,000 rms symmetrical amperes and read upwards to the A-B line. From this point, read horizontally to the left and read the instantaneous peak let-thru current of 230,000 amperes. In a circuit with a typical 15% short-circuit power factor, the instantaneous peak of the available current is approximately 2.3 times the rms symmetrical value. This occurs since the A-B line on the chart has a 2.3:1 slope.

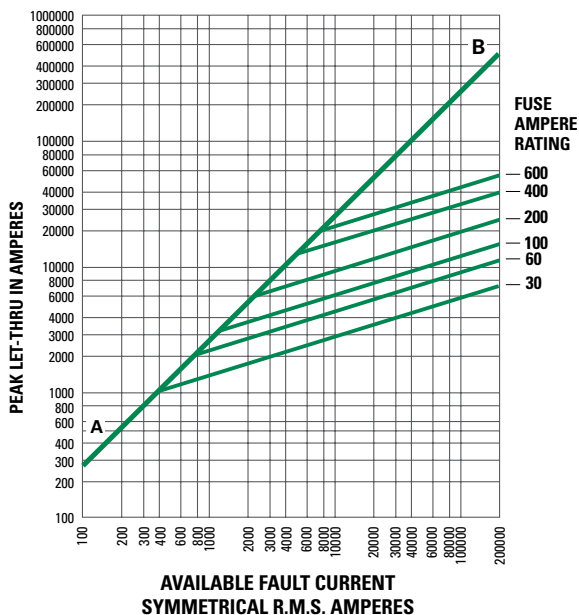

Figure 7 – Peak Let-through Charts

The diagonal curves that branch off the A-B line illustrate the current-limiting effects of different fuse ampere ratings for a given fuse series. To continue the example from above, enter the chart in *Figure 7* on the bottom at 100,000 rms symmetrical amperes and read upwards to the intersection of the 200 ampere fuse curve. Now read from this point horizontally to the left and read a peak let-through current of approximately 20,000 amperes.

What this tells us is that the 200 ampere fuse has reduced the peak current during the fault from 230,000 amperes to 20,000 amperes. In other words, this is the current-limiting effect of the 200 ampere fuse. 20,000 amperes is less than one-tenth of the available current. This is important because the magnetic force created by current flow is a function of the peak current squared. If the peak let-through current of a current-limiting fuse is one-tenth of the available peak, the magnetic force is reduced to less than 1/100 of what would occur without the fuse.

Using the Peak Let-through Charts (“Up-Over-and-Down”)

Peak Let-through Charts for Littelfuse POWR-GARD® fuses can be found online at littelfuse.com/technicalcenter. These charts are useful in determining whether a given fuse can properly protect a specific piece of equipment.

For example, given an available fault-current of 100,000 rms symmetrical amperes, determine whether 600 amp 250 volt time-delay Class RK1 fuses can sufficiently protect equipment that has a 22,000 amp short-circuit rating. Refer to *Figure 8*.

Start by locating the 100,000 A available fault-current on the bottom of the chart (Point A) and follow this value upwards to the intersection with the 600 amp fuse curve (Point B). Next, follow this point horizontally to the left to intersect with the A-B line (Point C). Finally, read down to the bottom of the chart (Point D) to read a value of approximately 18,000 amps.

Can the fuse selected properly protect the equipment for this application? Yes, the POWR-PRO® LLNRK 600 ampere RK1 current-limiting fuses have reduced the 100,000 amperes available current to an apparent or equivalent 18,000 amps. When protected by 600 amp LLNRK RK1 fuses, equipment with short-circuit ratings of 22,000 amps may be safely connected to a system having 100,000 available rms symmetrical amperes.

This method, sometimes referred to as the “Up-Over-and-Down” method, may be used to:

1. Provide back-up short-circuit protection to large air power circuit breakers.
2. Enable non-interrupting equipment such as bus duct to be

FUSE CHARACTERISTICS CURVES AND CHARTS

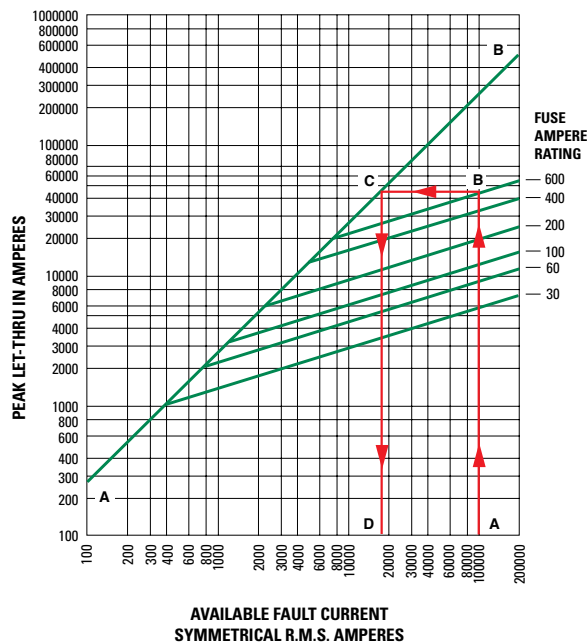

Figure 8 – Peak Let-through Chart for POWR-PRO® LLNRK Class RK1 Dual-Element Fuses Using the Up-Over-and-Down Method

installed in systems with available short-circuit currents greater than their short circuit (withstand) ratings.

However, this method may not be used to select fuses for backup protection of molded case or intermediate frame circuit breakers. National Electrical Code® (NEC®) Article 240.86 requires Series Ratings. Refer to the NEC® for more information.

UL Listed fuse-to-circuit breaker series ratings are now available from most national load center and panelboard manufacturers. Listings are shown in their product digests, catalogs, and online. Many local builders have also obtained fuse-to-circuit breaker series ratings. For additional information contact the Littelfuse Technical Support Group at 1-800-TEC-FUSE (1-800-832-3873).

Short-Circuit Current Rating (SCCR)

Since 2005, the NEC® has required Industrial Control Panels to be labeled with their SCCR. These labels allow users and inspectors to compare the SCCR of the equipment to the available fault current in order to avoid potential hazards in facilities.

Selective Coordination

A “coordinated” or “selective” system is a system whose overcurrent protective devices have been carefully chosen and their time-current characteristics coordinated.

Only the overcurrent device immediately on the line side of an overcurrent will open for any overload or short-circuit condition.

To further clarify, refer to the Terms and Definitions section for the definition of Selective Coordination and *Figure 15* for a graphical example.

Since the advent of electrical and electronic equipment, businesses have become entirely dependent on the continuous availability of electric energy. Loss of power halts all production and order processing, yet expenses continue to increase. Even many UPS systems become unintentionally non-selective causing power loss to computers and other critical equipment. Non-selectivity may defeat otherwise well-engineered UPS systems.

In a selective system, none of this occurs. Overloads and faults are disconnected by the overcurrent protective device immediately on the line side of the problem. The amount of equipment removed from service is minimized, the faulted or overloaded circuit is easier to locate, and a minimum amount of time is required to restore full service.

For these and many other reasons, selectivity is the standard by which many systems are judged and designed.

Fuse Selectivity

To get a better sense of how to ensure that fuses are selectively coordinated within an electrical system, refer to *Figure 4* shown earlier in this Technical Application Guide. This figure shows typical average melting time-current curves for one class of fuses. Note that the curves are roughly parallel to each other and that for a given overcurrent, the smaller fuse ratings respond quicker than the larger ratings. The heat energy required to open a fuse is separated into melting I^2t and arcing I^2t (see definition of Ampere-Squared-Seconds). The sum of these is the total clearing I^2t .

For a system to be considered coordinated, the smaller fuse total clearing I^2t must be less than the larger fuse melting I^2t . In other words, if the downstream (branch) fuse opens the circuit before the overcurrent affects the upstream (feeder) fuse element, the system will be considered selective. This can be determined by analyzing curves displaying melting and total clearing I^2t , or from minimum melting and maximum clearing time-current curves.

But the simplest method of coordinating low voltage power fuses is by using a Fuse Coordination Table such as the one shown in *Table 4*. This table is only applicable for the Littelfuse POWR-PRO® and POWR-GARD® fuse series listed. Tables such as this greatly reduce design time. For example, the coordination table shows that POWR-PRO KLPC Class L fuses coordinate at a two-to-one ratio with other Class L fuses, with POWR-PRO LLNRK / LLSRK / LLSRK_ID series

SELECTIVE COORDINATION

Class RK1 fuses, and POWR-PRO JTD / JTD_ID series Class J fuses.

In the system shown in *Figure 9*, the 3000 amp Class L main fuses are at least twice the ratings of the 1500, 1200, and 1000 amp Class L feeder fuses. Using the 2:1 ratio just referenced above, it is determined that these fuses will coordinate. The Coordination Table also shows that the LLSRK_ID series time-delay RK1 feeder and branch circuit fuses coordinate at a two-to-one ratio with the Class L feeder fuses, so the entire system in *Figure 9* would be considered 100% coordinated.

Circuit Breaker Coordination

As a result of the numerous types of circuit breakers and circuit breaker trip units available in today's market, developing a coordinated circuit breaker system or coordinating circuit breakers with fuses is beyond the scope of this Technical Application Guide. For further questions, contact the Littelfuse Technical Support Group.

NEC® Requirements for Selective Coordination

Component Short-Circuit Protecting Ability

As shown in *Figure 10*, the NEC® requires equipment protection to be coordinated with overcurrent protective devices and the available fault current in order to prevent extensive damage to the equipment. Essentially, this means that electrical equipment must be capable of withstanding heavy overcurrents without damage or be

properly protected by overcurrent protective devices that will limit damage.

When a severe fault occurs in an unprotected circuit, current immediately increases to a very high value. This is the available or prospective fault current. Some fuses respond so quickly to the increasing current that they interrupt current within the first half-cycle - or before the current even reaches its first peak. This is illustrated in *Figure 6* found earlier in the Technical Application Guide. Such fuses are termed "current-limiting fuses."

Current-limiting fuses stop damaging current faster than any other protective device, and greatly reduce or totally prevent component damage from high fault currents. This performance capability helps users meet the NEC® Article 110.10 requirements listed in *Figure 10*.

Pre-Engineered Solutions

Applicable code requirements also continue to expand with each new edition of the National Electrical Code®. As of the 2014 edition of the NEC®, the following requirements need to be met – and can be, utilizing Littelfuse POWR-GARD® Pre-Engineered Solutions:

- NEC 517.26 – Healthcare Essential Electrical Systems
- NEC 620.82 – Elevators
- NEC 700.32 – Emergency Systems
- NEC 701.27 – Legally Required Standby Systems
- NEC 708.54 – Critical Operations Power Systems

LINE-SIDE FUSES			LOAD-SIDE FUSES										
AMPERE RANGE	UL CLASS	LITTELFUSE CATALOG NUMBER	TIME-DELAY FUSES AMPERE RANGE, UL CLASS AND CATALOG NO.							FAST-ACTING FUSES AMPERE RANGE, UL CLASS AND CATALOG NO.			
			601-6000 L	601-4000 L	30-600 RK1	30-600 J	30-600 RK5	0-30 CC	30-600 RK1	30-1200 T	30-600 J	1-60 G	
			KLPC LDC	KLLU	LLNRK LLSRK_ID	JTD_ID JTD	FLNR_ID FLSR_ID IDSR	CCMR	KLNR KLSR	JLLN JLLS	JLS	SLC	
601-6000	L	KLPC	2:1	2:1	2:1	2:1	4:1	2:1	2:1	2:1	2:1	2:1	N/A
601-4000	L	KLLU	2:1	2:1	2:1	2:1	4:1	2:1	2:1	2:1	2:1	2:1	N/A
601-2000	L	LDC	2:1	2:1	2:1	2:1	4:1	2:1	2:1	2:1	2:1	2:1	N/A
30-600	RK1	LLNRK	N/A	N/A	2:1	2:1	8:1	2:1	3:1	3:1	3:1	3:1	4:1
30-600	RK1	LLSRK_ID	N/A	N/A	2:1	2:1	8:1	2:1	3:1	3:1	3:1	3:1	4:1
30-600	J	JTD_ID	N/A	N/A	2:1	2:1	8:1	2:1	3:1	3:1	3:1	3:1	4:1
30-600	RK5	IDSR	N/A	N/A	1.5:1	1.5:1	2:1	2:1	1.5:1	1.5:1	1.5:1	1.5:1	1.5:1
30-600	RK5	FLNR_ID	N/A	N/A	1.5:1	1.5:1	2:1	2:1	1.5:1	1.5:1	1.5:1	1.5:1	1.5:1
30-600	RK5	FLSR_ID	N/A	N/A	1.5:1	1.5:1	2:1	2:1	1.5:1	1.5:1	1.5:1	1.5:1	1.5:1
30-600	RK1	KLNR	N/A	N/A	3:1	3:1	8:1	N/A	3:1	3:1	3:1	3:1	4:1
30-600	RK1	KLSR	N/A	N/A	3:1	3:1	8:1	N/A	3:1	3:1	3:1	3:1	4:1
30-1200	T	JLLN	N/A	N/A	3:1	3:1	8:1	N/A	3:1	3:1	3:1	3:1	4:1
30-1200	T	JLLS	N/A	N/A	3:1	3:1	8:1	N/A	3:1	3:1	3:1	3:1	4:1
30-600	J	JLS	N/A	N/A	3:1	3:1	8:1	N/A	3:1	3:1	3:1	3:1	4:1
1-60	G	SLC	N/A	N/A	3:1	3:1	4:1	N/A	2:1	2:1	2:1	2:1	2:1

Table 4 – Fuse Coordination Table. Selecting the Correct Fuse Ampere Ratio to Maintain Selectively Coordinated Systems. (Ratios are expressed as Line-Side Fuse to Load-Side Fuse.)

10
Technical

SELECTIVE COORDINATION

The Littelfuse product line of Pre-Engineered Solutions includes:

- LPS Series POWR-Switch (single elevator shunt-trip disconnect switch)
- LCP Selective Coordination Panel

These products continue to gain in popularity because they meet NEC® requirements and offer simple, economical solutions for a variety of applications.

Visit littelfuse.com/lcp for more information on Littelfuse Pre-Engineered Solution products and corresponding selective coordination requirements.

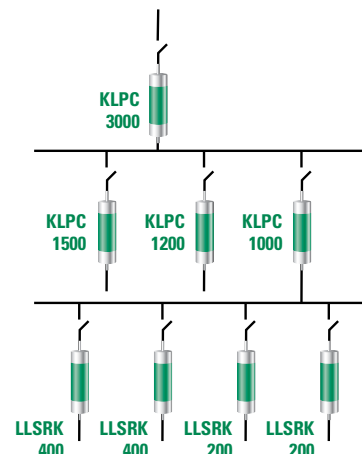

Figure 9 – Example of Selectively Coordinated Fused System

NATIONAL ELECTRICAL CODE®

ARTICLE 110 – Requirements for Electrical Installations

I. General

110.3. Examination, Identification, Installation, and Use of Equipment.

(A) Examination. In judging equipment, considerations such as the following shall be evaluated:

- (5)** Heating effects under normal conditions of use and also under abnormal conditions likely to arise in service.
- (6)** Arcing effects.

(B) Installation and Use. Listed or labeled equipment shall be used or installed in accordance with any instructions included in the listing or labeling.

110.9 Interrupting Rating. Equipment intended to interrupt current at fault levels shall have an interrupting rating at nominal circuit voltage sufficient for the current that is available at the line terminals of the equipment.

Equipment intended to interrupt current at other than fault levels shall have an interrupting rating at nominal circuit voltage sufficient for the current that must be interrupted.

110.10 Circuit Impedance, Short-Circuit Current Ratings, and Other Characteristics. The overcurrent protective devices, the total impedance, the equipment short-circuit current ratings, and other characteristics of the circuit to be protected shall be selected and coordinated to permit the circuit protective devices used to clear a fault to do so without extensive damage to the electrical equipment of the circuit. This fault shall be assumed to be either between two or more of the circuit conductors or between any circuit conductor and the equipment grounding conductor(s) permitted in 250.118. Listed equipment applied in accordance with their listing shall be considered to meet the requirements of this section.

ARTICLE 240 – Overcurrent Protection

240.1 Scope. Parts I through VII of this article provide the general requirements for overcurrent protection and overcurrent protective devices not more than 1000 volts, nominal. Part VIII covers overcurrent protection for those portions of supervised industrial installations operating at voltages of not more than 1000 volts, nominal. Part IX covers overcurrent protection over 1000 volts, nominal.

Informational Note: Overcurrent protection for conductors and equipment is provided to open the circuit if the current reaches a value that will cause an excessive or dangerous temperature in conductors or conductor insulation. See also Articles 110.9 for requirements for interrupting ratings and 110.10 for requirements for protection against fault currents.

(Reproduced by permission of NFPA per 2014 Edition of NEC)

Figure 10 – National Electrical Code Requires Effective Overcurrent Protection

UL/CSA FUSE CLASSES AND APPLICATIONS

Overcurrent and short-circuit protection of power and lighting feeders and branch circuits

Current Limiting

Fuses which meet the requirements for current limiting fuses are required to be labeled "Current Limiting". Fuse labels must include: UL/CSA fuse class, manufacturer's name or trademark, current rating, AC and/or DC voltage rating, and AC and/or DC interrupting rating. "Time Delay," "D," "TD" or equivalent may also be included on the label when the fuse complies with the time delay requirements of its class.

CLASS L

STANDARDS: UL Standard 248-10,
CSA Standard C22.2, No. 106, classified as HRCI-L

VOLTAGE RATING: 600 volts, AC and/or DC

CURRENT RATINGS: 601-6000 amps
KLPC also available 200-600A; LDC also available 150-600A

INTERRUPTING RATING: AC: 200,000 amps rms symmetrical
DC: 50,000, 100,000, or 200,000 amps

Not interchangeable with any other UL fuse class.
Time delay: Class L fuses may be marked "Time-Delay" although UL does not investigate time-delay characteristics of Class L fuses.
KLPC & KLLU: 10 seconds at 500% current rating
LDC: 4 seconds at 500% current rating

LF SERIES: KLPC, KLLU, LDC

PAGE: 8

CLASS R

STANDARDS: UL Standard 248-12,
CSA Standard C22.2, No. 106, classified as HRCI-R

VOLTAGE RATINGS: 250 and 600 volts, AC; 125 and 300 volts DC

CURRENT RATINGS: 0-600 amps

INTERRUPTING RATING: 200,000 amps rms symmetrical

TWO CLASSES: RK1 and RK5
Time delay is optional for Class R fuses.
Time Delay fuses are required to hold 500% current rating for a minimum of ten seconds. Same dimensions as UL Class H fuses, terminals modified to provide rejection feature. Fits UL Class R fuse holders which reject non Class R fuses.
Physically interchangeable with UL Class H, NEMA Class H, and UL Classes K1 & K5 when equipment has Class H fuse holders.

CLASS RK1

High degree of current limitation. Provides IEC Type 2 (no damage) protection for motor starters and control components. Time Delay optional, LLSRK_ID Series provides visual indication of blown fuse.

LF SERIES: Time Delay: LLNRK, LLSRK, LLSRK_ID
Fast Acting: KLNLR, KLSLR

PAGE: 13

CLASS RK5

Moderate degree of current limitation, adequate for most applications. Time delay optional. FLNR_ID, FLSR_ID and IDSR series provides visual indication of blown fuse.

LF SERIES: FLNR, FLNR_ID, FLSR, FLSR_ID, and IDSR

PAGE: 16

CLASS J

STANDARDS: UL Standard 248-8,
CSA Standard C22.2, No. 106, classified as HRCI-J

VOLTAGE RATING: 600 volts, AC

CURRENT RATINGS: 0-600 amps

INTERRUPTING RATING: 200,000 amps rms symmetrical

Not interchangeable with any other UL fuse class.
Time delay optional: Minimum of 10 seconds at 500% current rating.

LF SERIES: Time Delay: JTD_ID, JTD
Fast Acting: JLS

PAGE: 21

CLASS CC/CD

STANDARDS: UL Standard 248-4,
CSA Standard C22.2, No. 106, classified as HRCI Misc.

VOLTAGE RATING: 600 volts, AC

CURRENT RATINGS: UL Class CC: 0-30 amps
UL Class CD: 35-60 amps

INTERRUPTING RATINGS: 200,000 amps rms symmetrical
Time delay optional: Minimum of 12 seconds at 200% current rating.

LF SERIES: Time Delay: CCMR (motors), KLDR (transformers)
Fast Acting: KLKR

PAGE: 27

CLASS T

STANDARDS: UL Standard 248-15
CSA Standard C22.2, No. 106, classified as HRCI-T

VOLTAGE RATINGS: 300 and 600 volts AC, 125 and 300 volts DC

CURRENT RATINGS: 0-1200 amps
900 to 1200 amps UL Recognized for 600V version

INTERRUPTING RATING: 200,000 amps rms symmetrical
Fast-Acting fuses. High degree of current limitation.
Very small fuses; space-saving and non-interchangeable with any other UL fuse class.

LF SERIES: JLLN, JLLS

PAGE: 24

CLASS G

STANDARDS: UL Standard 248-5
CSA Standard C22.2, No. 106, classified as HRCI Misc.

VOLTAGE RATING: 480 volts, AC

CURRENT RATINGS: 0-60 amps

INTERRUPTING RATING: 100,000 amps rms symmetrical

Not interchangeable with any other UL fuse class.
Time delay optional: Minimum of 12 seconds at 200% current rating.

LF SERIES: SLC

PAGE: 26

CLASS K

STANDARDS: UL Standard 248-9; No CSA Standard

VOLTAGE RATINGS: 250 and 600 volts, AC

CURRENT RATING: 0-600 amps

INTERRUPTING RATINGS: Three permitted: 50,000, 100,000, and 200,000 amps rms symmetrical

Time delay is optional for Class K fuses.
Time Delay fuses are required to hold 500% current rating for a minimum of ten seconds. Same Dimensions and Physically interchangeable with UL Class H fuse holders. Class K fuses are not permitted to be labeled Current Limiting because there is no rejection feature as required by NEC® Article 240-60(B).

CLASS K1

Same prescribed degree of current limitation as RK1 fuses when tested at 50,000 or 100,000 amps rms symmetrical.

LF SERIES: Time Delay: LLNRK, LLSRK
Fast Acting: KLNLR, KLSLR

PAGE: 13

CLASS K5

Same prescribed degree of current limitation as RK5 fuses when tested at 50,000 or 100,000 amps rms symmetrical.

LF SERIES: NLN, NLS

PAGE: 20

UL/CSA FUSE CLASSES AND APPLICATIONS

Overcurrent and short-circuit protection of power and lighting feeders and branch circuits

FUSES FOR SUPPLEMENTARY OVERCURRENT PROTECTION

STANDARDS: UL Standard 248-14; CSA Standard C22.2, No. 59-1. Three Classifications covered:
NOTE: Fuses may be rated for AC and/or DC when suitable for such use.

(1) **MICRO FUSES**

Voltage ratings: UL, 125 volts; CSA, 0-250 volts
 Current ratings: UL, 0-10 amps; CSA, 0-60 amps
 Interrupting rating: 50 amps rms symmetrical

(2) **MINIATURE FUSES** (CSA classifies these as Supplemental Fuses)

Voltage ratings: UL, 125 or 250 volts; CSA, 0-600 volts
 Current ratings: UL, 0-30 amps; CSA, 0-60 amps
 Interrupting rating: 10,000 amps rms symmetrical

(3) **MISCELLANEOUS CARTRIDGE FUSES** (CSA classifies these as Supplemental Fuses)

Voltage ratings: UL, 125-1000 volts; CSA, 0-100 volts
 Current ratings: UL, 0-30 amps; CSA 0-60 amps
 Interrupting ratings: 10,000, 50,000, or 100,000 amps rms symmetrical
 Time delay (Optional); Minimum delay at 200% fuse rating:
 5 seconds for fuses rated 3 amps or less
 12 seconds for fuses rated more than 3 amps

LF SERIES: BLF, BLN, BLS, FLA, FLM, FLQ, FLU, KLK, KLO, KLKD, SPF
NOTE: Littelfuse electronic fuses are also covered by these standards; see electronic section of this catalog, or littelfuse.com for complete listing.

PAGE: 30

SPECIAL PURPOSE FUSES

There are no UL Standards covering this category of fuses. These fuses have special characteristics designed to protect special types of electrical or electronic equipment such as diodes, SCR, transistors, thyristors, capacitors, integrally fused circuit breakers, parallel cable runs, etc.

Fuses may be UL Recognized for use as a component in UL Listed equipment. UL Recognized fuses are tested for characteristics such as published interrupting capacity. They are also covered by UL re-examination service.

Non-renewable

VOLTAGE RATINGS: up to 1000 volts AC and/or DC

AMPERE RATINGS: up to 6000 amperes

INTERRUPTING RATINGS: up to 200,000 amperes

Many of these fuses are extremely current limiting. When considering application of these fuses, or if you have special requirements, contact Littelfuse Technical Support Group for assistance.

LF SERIES: KLC, L15S, L25S, L50QS, L50S, L60S, L70QS, L70S, JLLS 900 amp through 1200 amp

PAGES: 70

Non-Current Limiting

STANDARDS:

CLASS H

UL Standard 248-6
 CSA Standard C22.2, No. 59.1
 Also known as NEMA Class H, and sometimes referred to as "NEC" or "Code" fuses

VOLTAGE RATINGS: 250 and 600 volts, AC

AMPERE RATINGS: 0-600 amps

INTERRUPTING RATINGS: 10,000 amps rms symmetrical

Two types: one-time and renewable

Physically interchangeable with UL Classes K1 & K5;

Fits UL Class H fuse holders which will also accept K1, K5, RK5, and RK1 fuses.

Manufacturers are upgrading Class H One-time fuses to Class K5 per UL Standard 248-9D, See Class K fuses.

ONE-TIME FUSES (NON-RENEWABLE)

Time delay: Optional
 Time-delay fuses must hold 500% current rating for a minimum of ten seconds.

LF SERIES: NLKP

PAGE: 20

RENEWABLE FUSES

Only Class H fuses may be renewable. While time delay is optional, no renewable fuses meet requirements for time delay. Some renewable fuses have a moderate amount of time delay, referred to as "time lag" to differentiate from true time delay.

LF SERIES: Discontinued - Please cross to RK5 or RK1 class fuses

PLUG FUSES

STANDARDS:

UL Standard 248-11,
 CSA Standard C22.2, No. 59.1

VOLTAGE RATINGS: 125 volts AC only

AMPERE RATINGS: 0-30 amps

INTERRUPTING RATINGS: 10,000 amps rms symmetrical. Interrupting rating need not be marked on fuse.

Two types: Edison-base and Type S

EDISON-BASE: Base is same as standard light bulb. All amp ratings interchangeable. NEC® permits Edison-base plug fuses to be used only as replacements for existing fuses, and only when there is no evidence of tampering or overfusing.

TYPE S: Not interchangeable with Edison-base fuses unless non-removable Type S fuse adapter is installed in Edison-base fuse socket. To prevent overfusing, adapters have three ampere ratings: 10-15, 16-20, and 21-30 amps.

Time delay: Fuses may be time delay, if so, they are required to hold 200% of rating for 12 seconds minimum.

NOTE: Plug fuses may be used where there is not more than 125 volts between conductors or more than 150 volts from any conductor to ground. This permits their use in 120/240 volts grounded, single-phase circuits.

LF SERIES: Edison-base: TOO, TLO
 Type S: SOO, SLO
 Type S Adapters: SAO

PAGE: 65



Additional Resources and POWR-GARD® Products

Littelfuse is continually developing new technical resources and products that meeting evolving industry standards. For the latest information, visit:

littelfuse.com

TERMS AND DEFINITIONS

Adjustable Alarm Level – A setting on a protection relay at which an LED or an output contact operates to activate a visual or audible alarm.

Adjustable Time Delay – A setting on a protection relay that determines the time between the fault detection and relay operation.

AIC or A.I.C. – See Interrupting Capacity.

AIR or A.I.R. – See Interrupting Rating.

Alarm Relay Contact – The output of the relay that acts as a switch and is connected to a visual or audible alarm.

Ambient Temperature – The air temperature surrounding a device. For fuses or circuit breakers in an enclosure, the air temperature within the enclosure.

Ampacity – The current in amperes that a conductor can carry continuously under the conditions of use without exceeding its temperature rating. It is sometimes informally applied to switches or other devices which are more properly referred to by their ampere rating.

Ampere Rating – The current rating, in amperes, that is marked on fuses, circuit breakers, or other equipment.

Ampere-Squared-Seconds (I^2t) – A means of describing the thermal energy generated by current flow. When a fuse is interrupting a current within its current-limiting range, the term is usually expressed as melting, arcing, or total clearing I^2t .

- Melting I^2t is the heat energy passed by a fuse after an overcurrent occurs and until the fuse link melts. It equals the rms current squared multiplied by the melting time in seconds. For times less than 0.004 seconds, melting I^2t approaches a constant value for a given fuse.
- Arcing I^2t is the heat energy passed by a fuse during its arcing time. It is equal to the rms arcing current squared (see definition below), multiplied by arcing time.
- Clearing I^2t (also Total Clearing I^2t) is the ampere-squared seconds (I^2t) through an overcurrent device from the inception of the overcurrent until the current is completely interrupted. Clearing I^2t is the sum of the Melting I^2t plus the Arcing I^2t .

Analog Output – A 0–1 mA, 4–20 mA or 0–5 Vdc signal from a protection relay used to pass information to a device or controller.

Arc-Blast – A pressure wave created by the heating, melting, vaporization, and expansion of conducting material and surrounding gases or air.

Arc-Flash – The sudden release of heat energy and intense light at the point of an arc. Can be considered a short-circuit through the air, usually created by accidental contact between live conductors.

Arc Gap – The distance between energized conductors or between energized conductors and ground. Shorter arc gaps result in less energy being expended in the arc, while longer gaps reduce arc current. For 600 volts and below, arc gaps of 1.25 inches (32 mm) typically produce the maximum incident energy.

Arc Rating – A rating assigned to material(s) that relates to the maximum incident energy the material can resist before break open of the material or onset of a second-degree burn. The arc rating is typically shown in cal/cm².

Arcing Current (See *Figure 11*) – The current that flows through the fuse after the fuse link has melted and until the circuit is interrupted.

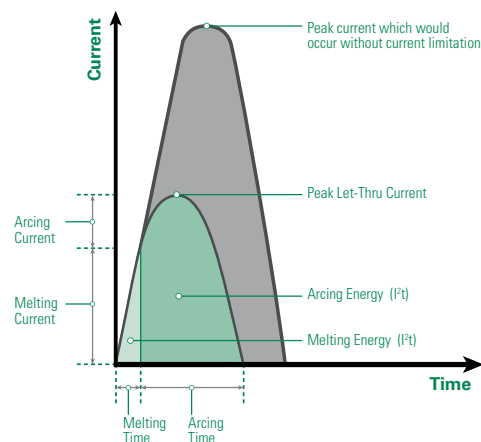

Figure 11 – Arcing and melting currents plus arcing, melting and clearing times

Arcing I^2t – See Ampere-Squared-Seconds (I^2t).

Arcing Fault – A short-circuit that arcs at the point of fault. The arc impedance (resistance) tends to reduce the short-circuit current. Arcing faults may turn into bolted faults by welding of the faulted components. Arcing faults may be phase-to-phase or phase-to-ground.

Arcing Time (See *Figure 11*) – The time between the melting of a fuse link or parting of circuit breaker contacts, until the overcurrent is interrupted.

Arc Voltage (See *Figure 12*) – Arc voltage is a transient voltage that occurs across an overcurrent protection device during the arcing time. It is usually expressed as peak instantaneous voltage (V_{peak} or E_{peak}), or on rare occasion as rms voltage.

Asymmetrical Current – See Symmetrical Current.

Available Short-Circuit Current (also Available or Prospective Fault Current) – The maximum rms Symmetrical Current that would flow at a given point in a system under bolted-fault conditions. Short-circuit current is maximum during the first half-cycle after the fault occurs. See definitions of Bolted Fault and Symmetrical Current.

TERMS AND DEFINITIONS

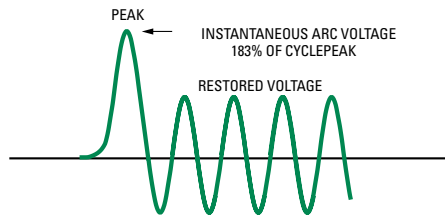

Figure 12 – Transient overvoltage during arcing time

Blade Fuse – See Knife Blade Fuse.

Body – The part of a fuse enclosing the fuse elements and supporting the contacts. Body is also referred to as cartridge, tube, or case.

Bolted Fault – A short-circuit that has no electrical resistance at the point of the fault. It results from a firm mechanical connection between two conductors, or a conductor and ground. Bolted faults are characterized by a lack of arcing. Examples of bolted faults are a heavy wrench lying across two bare bus bars, or a crossed-phase condition due to incorrect wiring.

Boundaries of Approach – Protection boundaries established to protect personnel from shock and Arc-Flash hazards.

Calorie – The amount of heat needed to raise the temperature of one gram of water by one degree Celsius. 1 cal/cm² is equivalent to the exposure on the tip of a finger by a cigarette lighter for one second.

Cartridge Fuse – A fuse that contains a current-responsive element inside a tubular fuse body with cylindrical ferrules (end caps).

Case Size (also Cartridge Size) – The maximum allowable ampere rating of a cartridge fuse having defined dimensions and shape. For example, case sizes for UL Listed Class H, K, J, RK1, and RK5 are 30, 60, 100, 200, 400, and 600 amperes. The physical dimensions vary with fuse class, voltage, and ampere rating. UL Standards establish the dimensions for each UL Fuse Class. This catalog's product section contains case size dimensions for all Littelfuse POWR-GARD® fuses.

Clearing I²t – See Ampere-Square-Seconds (I²t).

Clearing Time (see Figure 11) – The time between the initiation of an overcurrent condition to the point at which the overcurrent is interrupted. Clearing Time is the sum of Melting Time and Arcing Time.

Conformal Coating – Coating used to protect circuit boards from pollutants, corrosion, and mildew.

Contacts (Fuse) – The external metal parts of the fuse used to complete the circuit. These consist of ferrules, caps, blades or terminals, as shown in this catalog.

Coordination or Coordinated System – See Selective Coordination.

Continuous Load – An electrical load where the maximum current is expected to continue for three hours or more.

CT Loop – The electrical circuit between a current transformer and a protection relay or monitoring device.

Current-Based Protection – Protection parameters (trip-levels/ data collection etc.) derived from current levels in a circuit.

Current-limiting Fuse (See Figure 13) – A fuse which, when interrupting currents within its current-limiting range, reduces the current in the faulted circuit to a magnitude substantially less than that obtainable in the same circuit if the device was replaced with a solid conductor having comparable impedance. To be labeled “current limiting,” a fuse must mate with a fuse block or fuse holder that has either a rejection feature or dimensions that will reject non-current-limiting fuses.

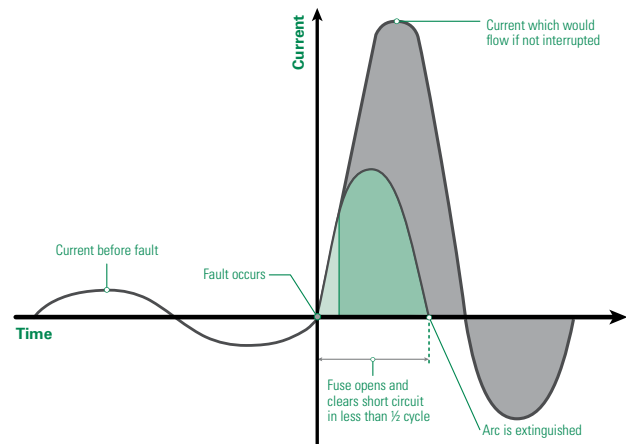

Figure 13 – Current-limiting Fuse

Current-limiting Range – For an individual overcurrent protective device, the current-limiting range begins at the lowest value of rms symmetrical current at which the device becomes current-limiting (the threshold current) and extends to the maximum interrupting capacity of the device. See definitions of Threshold Current and Interrupting Capacity.

Current Rating – See Ampere Rating.

Current Transformer (CT) – A transformer that produces a current in its secondary circuit in a known proportion to current in its primary circuit.

Data Logging – Collecting and storing information in a format that can be reviewed for trending, troubleshooting and reporting.

DFT (Discrete Fourier Transform) Harmonic Filter – An algorithm used to measure the fundamental component of current and voltage and reject harmonics. This allows lower trip settings and eliminates nuisance trips due to harmonics.

TERMS AND DEFINITIONS

Distance to Arc – Refers to the distance from the receiving surface to the arc center. The value used for most calculations is typically 18 inches.

Dual-Element Fuse – A fuse with internal construction consisting of a separate time-delay overload element(s) that interrupts overcurrents up to approximately 500%-600% of its nominal rating, plus separate fuse links that quickly open higher value currents. All dual-element fuses have time delay, but, since there are other methods of achieving time delay, not all time-delay fuses have dual-element construction. See Time-Delay Fuse.

EFCT (Earth Fault Current Transformer) – A current transformer engineered to accurately detect low level ground-fault current.

Electrical Hazard Analysis – A study performed to identify the potential electrical hazards to which personnel may be exposed. The analysis should address both shock and Arc-Flash hazards.

Electrically Safe Work Condition – Condition where the equipment and or circuit components have been disconnected from electrical energy sources, locked/tagged out, and tested to verify all sources of power are removed.

Element – A fuse's internal current-carrying components that melt and interrupt the current when subjected to an overcurrent of sufficient duration or value. Also called fuse link.

Fail-Safe Mode (also known as Under Voltage or UV) – Output relay is energized during normal (not tripped) operation. If the protection relay loses supply voltage, the system will trip or alarm.

Fast-Acting Fuse – May also be termed Normal-opening fuse, this is a fuse that has no intentional or built-in time delay. Actual opening time is determined by the fuse class, the overcurrent, and other conditions. Fast-acting is indicated on the fuse label by "Fast-Acting," "F-A," "F," or other suitable marking.

Fault – Same as Short-Circuit and used interchangeably.

Fault Current – The current that flows when a phase conductor is faulted to another phase or ground.

Feeder Protection – Overcurrent or overvoltage devices installed on a feeder circuit to supplement, compliment or replace downstream protective devices.

Filler – A material, such as granular quartz, used to fill a section or sections of a fuse and aid in arc quenching.

Filter – An algorithm used to measure the fundamental component of current and voltage and reject harmonics. This allows lower trip settings and eliminates nuisance trips due to harmonics.

Flash Hazard Analysis – A study that analyzes potential exposure to Arc-Flash hazards. The outcome of the study establishes Incident Energy levels, Hazard Risk Categories,

Flash Protection Boundaries, and required PPE. It also helps define safe work practices.

Flash Protection Boundary – A protection boundary established to protect personnel from Arc-Flash hazards. The Flash Protection Boundary is the distance at which an unprotected worker can receive a second-degree burn to bare skin.

Fuse – An overcurrent protective device consisting of one or more current carrying elements enclosed in a body fitted with contacts, so that the fuse may be readily inserted into or removed from an electrical circuit. The elements are heated by the current passing through them, thus interrupting current flow by melting during specified overcurrent conditions.

Ground Continuity Monitor - A protection relay that continuously monitors a ground conductor and trips if this conductor opens or shorts to the ground-check conductor.

Ground-Fault – Unintentional contact between a phase conductor and ground or equipment frame. The words "ground" and "earth" are used interchangeably when it comes to electrical applications.

Ground-Fault Current – The current that returns to the supply neutral through the ground-fault and the ground-return path.

Ground-Fault Protection – A system that protects equipment from damaging ground-fault current by operating a disconnecting means to open all ungrounded conductors of a faulted circuit. This protection is at current levels less than those required to operate a supply circuit overcurrent device.

Ground-Fault Relay – A protection relay designed to detect a phase-to-ground-fault on a system and trip when current exceeds the pickup setting for greater than the trip time setting.

Hazard Risk Category – A classification of risks (from 0 to 4) defined by NFPA 70E®. Each category requires PPE and is related to incident energy levels.

High-Resistance Grounding – Achieved when a neutral-ground resistor (NGR) is used to limit the current to a low level. Typically high-resistance grounding is 25 A and lower. See Low-Resistance Grounding.

I²t – See Ampere-Squared-Seconds (I²t).

IEEE Device Numbers – The devices in switching equipment are referred to by numbers, according to the functions they perform. These numbers are based on a system which has been adopted as standard for automatic switchgear by IEEE. This system is used on connection diagrams, in instruction books and in specifications.

IECType 2 Protection – Fused protection for control components that prevents damage to these components under short-circuit conditions. See definition of No Damage.

TERMS AND DEFINITIONS

Incident Energy – The amount of thermal energy impressed on a surface generated during an electrical arc at a certain distance from the arc. Typically measured in cal/cm².

Instantaneous Peak Current (I_p or I_{peak}) – The maximum instantaneous current value developed during the first half-cycle (180 electrical degrees) after fault inception. The peak current determines magnetic stress within the circuit. See Symmetrical Current.

Insulation Monitoring – Monitoring the resistance from phase to ground to detect insulation breakdown on a system.

Interrupting Capacity (AIC) – The highest available symmetrical rms alternating current (for DC fuses the highest direct current) at which the protective device has been tested, and which it has interrupted safely under standardized test conditions. The device must interrupt all available overcurrents up to its interrupting capacity. Also commonly called interrupting rating. See Interrupting Rating below.

Interrupting Rating (IR, I.R., AIR or A.I.R.) – The highest RMS symmetrical current, at specified test conditions, which the device is rated to interrupt. The difference between interrupting capacity and interrupting rating is in the test circuits used to establish the ratings.

Inverse-time Characteristics – A term describing protective devices whose opening time decreases with increasing current.

IR or I.R. (also AIR or A.I.R.) – See Interrupting Rating above.

Kiloamperes (kA) – 1,000 amperes.

Knife Blade Fuse – Cylindrical or square body fuses with flat blade terminals extending from the fuse body. Knife blades may be designed for insertion into mating fuse clips and/or to be bolted in place. Knife blade terminals may include a rejection feature that mates with a similar feature on a fuse block of the same class.

Leakage Current – Very low level ground-fault current, typically measured in milliamperes (mA, thousandths of amperes).

Limited Approach Boundary – An approach boundary to protect personnel from shock. A boundary distance is established from an energized part based on system voltage. To enter this boundary, unqualified persons must be accompanied with a qualified person and use the proper PPE.

Low-Resistance Grounding – A Resistance Grounded System that allows high currents to flow during a ground-fault. Typically 100A and higher is considered Low-Resistance grounding. See High-Resistance Grounding.

Melting Current (see *Figure 11*) – The current that flows through the fuse from the initiation of an overcurrent condition to the instant arcing begins inside the fuse.

Melting I^2t – See Ampere-Squared-Seconds (I^2t).

Melting Time (see *Figure 11*) – The time span from the initiation of an overcurrent condition to the instant arcing begins inside the fuse.

Motor Protection – Overload protection designed to protect the windings of a motor from high current levels. Modern motor protection relays add many additional features, including metering, data logging and communications.

NEC – In general, the National Electrical Code® (NEC®). Specifically, as referenced herein, NEC refers to NFPA Standard 70, *National Electrical Code*, National Fire Protection Association, Quincy, MA 02269.

Sections of the NEC reprinted herein, and/or quotations there from, are done so with permission. The quoted and reprinted sections are not the official position of the National Fire Protection Association which is represented only by the Standard in its entirety. Readers are cautioned that not all authorities have adopted the most recent edition of the NEC; many are still using earlier editions.

Neutral Grounding Resistor (NGR) – A current-limiting resistor connecting the power-system neutral to ground.

No Damage – A term describing the requirement that a system component be in essentially the same condition after the occurrence of a short-circuit as prior to the short-circuit.

Non-renewable Fuse – A fuse that must be replaced after it has opened due to an overcurrent. It cannot be restored to service.

Normal-opening Fuse – See Fast-Acting Fuse.

Nuisance Trip – An undesired change in relay output due to misinterpreted readings.

One-time Fuse – Technically, any non-renewable fuse. However, the term usually refers to UL Class H fuses and to fast acting UL Class K5 fuses. Such fuses are not current-limiting and do not have a rejection feature. One-time fuses are also referred to as “Code” fuses.

Open CT Hazard – An open-circuited CT secondary can develop a dangerously high voltage when the primary is energized.

Overcurrent – Any current larger than the equipment, conductor, or devices are rated to carry under specified conditions.

Overload – An overcurrent that is confined to the normal current path (e.g., not a short-circuit), which if allowed to persist, will cause damage to equipment and/or wiring. Additional information regarding fuse applications for overload protection can be found earlier in this Technical Application Guide.

TERMS AND DEFINITIONS

Peak Let-through Current (See Figure 14) – The maximum instantaneous current that passes through an overcurrent protective device during its total clearing time when the available current is within its current-limiting range.

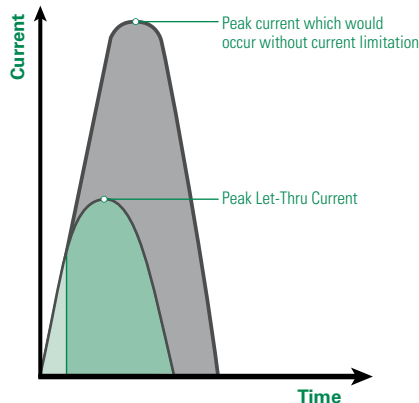

Figure 14 – Peak Let-through Current

Phase Current – The current present in a phase conductor.

Phase Voltage – The voltage measured between a phase conductor and ground.

Power Factor (X/R) – As used in overcurrent protection, power factor is the relationship between the inductive reactance (X) and the resistance (R) in the system during a fault. Under normal conditions a system may be operating at a 0.85 power factor (85%). When a fault occurs, much of the system resistance is shorted out and the power factor may drop to 25% or less. This may cause the current to become asymmetrical. See definition of Symmetrical Current. The UL test circuits used to test fuses with interrupting ratings exceeding 10,000 amperes are required to have a power factor of 20% or less. Since the power factor of test circuits tends to vary during test procedures, actual test circuits are usually set to a 15% power factor. The resulting asymmetrical current has an rms value of 1.33 times the available symmetrical rms. The instantaneous peak current of the first peak after the fault is 2.309 times the available symmetrical rms.

PPE – An acronym for Personal Protective Equipment. It can include clothing, tools, and equipment.

Primary Rating (for CTs) – The current rating of the primary side of a current transformer. The first number in the ratio 500:5 is the primary rating. Under ideal conditions 500 A of primary current flow through the CT will produce 5 A of current out the secondary terminals.

Prohibited Approach Boundary – An approach boundary to protect personnel from shock. Work in this boundary is considered the same as making direct contact with an energized part. Only qualified persons are allowed to enter this boundary and they must use the proper PPE.

Prospective Current – See Available Short-Circuit Current.

Protection Boundaries – Boundaries established to protect personnel from electrical hazards.

Pulsing – Modulating the ground-fault current on a resistance grounded system using a contactor to short out part of the NGR elements (or to open one of two NGRs connected in parallel). Another version of pulsing is imposing a higher frequency signal on power lines and using a wand detector to locate the point of fault on a conductor.

QPL (Qualified Products List) – A list of approved fuses and holders that meet various Military specifications.

Qualified Person – A person who is trained, knowledgeable, and has demonstrated skills on the construction and operation of the equipment, and can recognize and avoid electrical hazards that may be encountered.

Rating – A designated limit of operating characteristics based on definite conditions such as current rating, voltage rating and interrupting rating.

Rectifier Fuse – See High-Speed Semiconductor Fuses.

Rejection Feature – The physical characteristic(s) of a fuse block or fuse holder that prevents the insertion of a fuse unless it has the proper mating characteristics. This may be achieved through the use of slots, grooves, projections, or the actual physical dimensions of the fuse. This feature prevents the substitution of fuses of a Class or size other than the Class and size intended.

Relay – An electrical switch that opens and closes a contact (or contacts) under the control of another circuit. Typically an electromagnet.

Renewable Element (also Renewable Link) – A renewable fuse current-carrying component that is replaced to restore the fuse to a functional condition after the link opens due to an overcurrent condition.

Renewable Fuse – A fuse that may be readily restored to service by replacing the renewable element after operation.

Resistance-Grounded System – An electrical system in which the transformer or generator neutral is connected to ground through a current-limiting resistor. See Solidly Grounded System, Ungrounded System.

Restricted Approach Boundary – An approach boundary to protect personnel from shock. A boundary distance is established from an energized part based on system voltage. Only qualified persons are allowed in the boundary and they must use the proper PPE.

Selective Coordination (See Figure 15) – In a selectively coordinated system, only the protective device immediately on the line side of an overcurrent opens. Upstream protective devices remain closed. All other equipment remains in service, which simplifies the identification and location of overloaded

TERMS AND DEFINITIONS

equipment or short-circuits. For additional information, refer to the Selective Coordination pages of this Technical Application Guide.

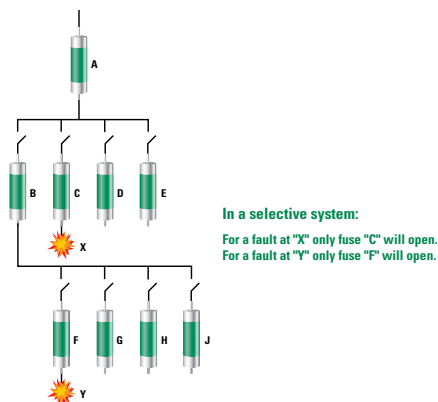

Figure 15 – Selective Coordination Example

Semiconductor Fuse – (Also known as High-Speed Fuses) A fuse specifically designed to protect semiconductors such as silicon rectifiers, silicon-controlled rectifiers, thyristors, transistors, and similar components.

Sensitive Ground-Fault Protection – Protection designed to accurately detect extremely low ground-fault current levels without nuisance tripping.

Shock – A trauma subjected to the body by electrical current. When personnel come in contact with energized conductors, it can result in current flowing through their body often causing serious injury or death.

Short-Circuit (See Figure 16) – A current flowing outside its normal path, caused by a breakdown of insulation or by faulty equipment connections. In a short-circuit, current bypasses the normal load. Current is determined by the system impedance (AC resistance) rather than the load impedance. Short-circuit currents may vary from fractions of an ampere to 200,000 amperes or more.

Short-Circuit Current Rating (SCCR) – The prospective symmetrical fault current at a nominal voltage to which an apparatus or system is able to be connected without sustaining damage exceeding defined acceptance criteria.

Short-Circuit Rating – The maximum RMS symmetrical short-circuit current at which a given piece of equipment has been tested under specified conditions, and which, at the end of the test is in essentially the same condition as prior to the test. Short-circuit ratings (also called withstand ratings) apply to equipment that will be subjected to fault currents, but which are not required to interrupt them. This includes switches, busway (bus duct), switchgear and switchboard structures, motor control centers and transformers.

Most short-circuit ratings are based on tests which last three complete electrical cycles (0.05 seconds). However, if the equipment is protected during the test by fuses or by a circuit breaker with instantaneous trips, the test duration is the time required for the overcurrent protective device to open the circuit.

When protected as such during testing, the equipment instructions and labels must indicate that the equipment shall be protected by a given fuse class and rating or by a specific make, type, and rating of circuit breaker. Circuit breakers equipped with short-delay trip elements instead of instantaneous trip elements have withstand (short-circuit) ratings in addition to their interrupting rating. The breaker must be able to withstand the available fault current during the time that opening is delayed.

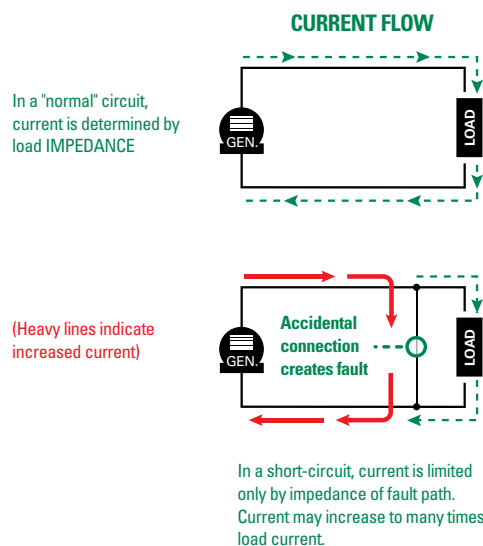

Figure 16 – Current Flow in Normal and Short Circuit Situations

Solidly Grounded System – An electrical system in which the neutral point of a wye connected supply transformer is connected directly to ground.

Symmetrical Current – The terms “Symmetrical Current” and “Asymmetrical Current” describe an AC wave symmetry around the zero axis. The current is symmetrical when the peak currents above and below the zero axis are equal in value, as shown in Figure 17 (next page). If the peak currents are not equal, as shown in Figure 18, the current is considered asymmetrical. The degree of asymmetry during a fault is determined by the change in power factor (X/R) and the point in the voltage wave when the fault occurs. See definition of Power Factor. In general, lower short-circuit power factors increase the degree of asymmetry.

TERMS AND DEFINITIONS

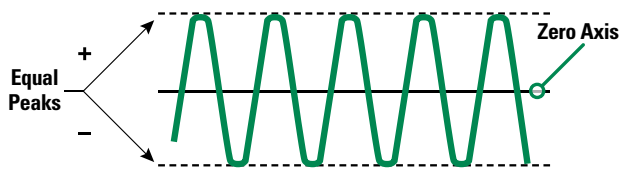

Figure 17 – Symmetrical Current

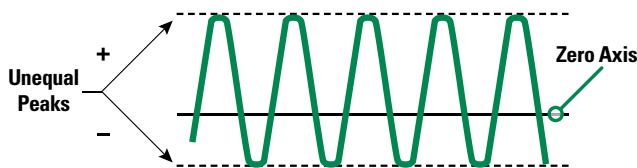

Figure 18 – Asymmetrical Current

Threshold Current – The minimum current for a given fuse size and type at which the fuse becomes current-limiting. It is the lowest value of available rms symmetrical current that will cause the device to begin opening within the first 1/4 cycle (90 electrical degrees) and completely clear the circuit within 1/2 cycle (180 electrical degrees). The approximate threshold current can be determined from the fuse’s peak let-through charts. (See Figure 19.)

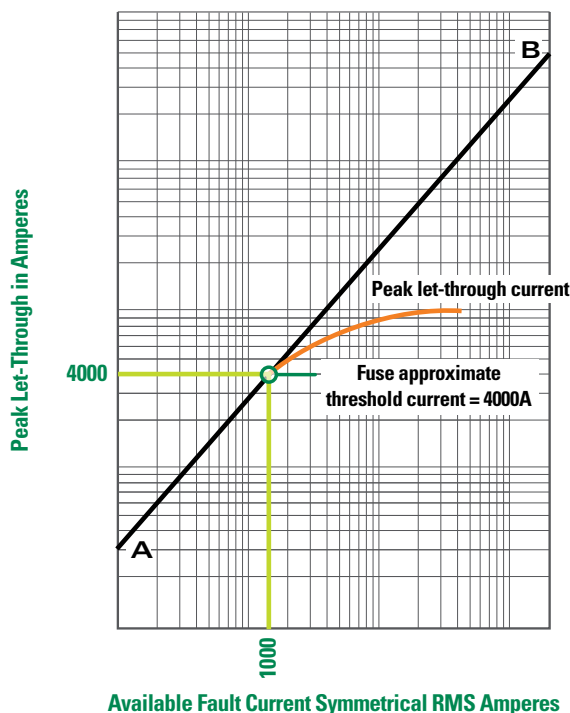

Figure 19 – Determining Threshold Current from Peak Let-through Chart

Threshold Ratio – Consists of the threshold current divided by the ampere rating of a specific type or class of overcurrent device. A fuse with a threshold ratio of 15 becomes current-limiting at 15 times its current rating.

Time-Delay Fuse – Fuses designed with an intentional, built-in delay in opening. When compared to fast-opening fuses, time-delay fuses have an increased opening time for overcurrents between approximately 200% and 600% of the fuse’s current rating. Time-delay is indicated on the fuse label by “Time-Delay,” “T-D,” “D,” or other suitable marking. Time-delay in the overload range (200%-600% of the fuse rating) permits the fuse to withstand system switching surges, motor starting currents, and other harmless temporary overcurrents.

UL Standards require time-delay Class H, K, RK1, RK5, and J fuses to hold 500% of their normal current rating for a minimum of 10 seconds. They must also pass the same opening time tests (135% and 200% of current rating) as fast acting fuses.

Time-delay Class CC, CD, G, Plug, and Miscellaneous fuses have different requirements. For more information, please refer to the corresponding descriptions provided in the Product Information Section.

For the UL Standard, Class L fuses have no standard time-delay. The time-delay varies from series to series for a given manufacturer, as well as from manufacturer to manufacturer. For reference, Littelfuse KLPC series POWR-PRO® fuses hold 500% of rated current for a minimum of 10 seconds.

Ungrounded System – An electrical system in which no point in the system is intentionally grounded. This was most common in process industries where continuity of service during a single-phase-to-ground-fault was required.

Unqualified Person – A person that does not possess all the skills and knowledge or has not been trained for a particular task.

Voltage Rating – The maximum rms AC voltage and/or the maximum DC voltage at which the fuse is designed to operate. For example, fuses rated 600 volts and below may be applied at any voltage less than their rating. There is no rule for applying AC fuses in DC circuits such as applying the fuse at half its AC voltage rating. Fuses used on DC circuits must have DC ratings.

Withstand Rating – See Short-Circuit.

MOTOR PROTECTION TABLES

Selection of Class RK5 Fuses (FLNR_ID / FLSR_ID / IDSR Series) or POWR-PRO® Class RK1 Fuses (LLNRK / LLSRK / LLSRK_ID Series) Based on Motor Full Load Amps

Using AC Motor Protection Tables to Select Fuse Ratings

Time-delay RK1 and RK5 fuse ratings selected in accordance with the following recommendations also meet NEC® requirements for Motor Branch circuit and Short-Circuit Protection.

Selecting Fuses for Motor Running Protection Based on Motor Horsepower

Motor horsepower and motor Full Load Amperes (FLA) shown are taken from NEC® Tables 430.248 through 430.250 covering standard speed AC motors with normal torque characteristics. Fuse ratings for motors with special characteristics may need to vary from given values.

If motor running protection will be provided by the fuses, select fuse ratings for correct type of motor from Motor Protection Table Columns headed, "Without Overload Relays."

If overload relays will provide principal motor running protection, select fuse ratings for correct type of motor from Motor Protection Table Columns headed, "Back-up Running Protection" or "With Overload Relays." Fuse ratings selected from these columns coordinate with most UL Class 10 and 20 overload relays which covers over 90% of motor applications.

Selecting Fuses for Motor Running Protection Based on Motor Actual Full Load Currents

Better protection is achieved when fuse ratings are based on motor actual FLA obtained from motor nameplates. Locate motor nameplate FLA in the column appropriate for the type of motor and type of protection required. Then select the corresponding ampere rating of the fuse from the first column of that line.

TIME DELAY UL CLASS RK1 OR RK5 FUSE AMPERE RATING	MOTOR RUNNING PROTECTION (USED WITHOUT PROPERLY SIZED OVERLOAD RELAYS) MOTOR FULL-LOAD AMPS		BACK-UP MOTOR RUNNING PROTECTION (USED WITH PROPERLY SIZED OVERLOAD RELAYS) MOTOR FULL-LOAD AMPS	
	MOTOR SERVICE FACTOR OF 1.15 OR GREATER OR WITH TEMP. RISE NOT OVER 40°C.	MOTOR SERVICE FACTOR LESS THAN 1.15 OR WITH TEMP. RISE GREATER THAN 40°C.	MOTOR SERVICE FACTOR OF 1.15 OR GREATER OR WITH TEMP. RISE NOT OVER 40°C.	MOTOR SERVICE FACTOR LESS THAN 1.15 OR WITH TEMP. RISE GREATER THAN 40°C.
1/10	0.08-0.09	0.09-0.10	0-0.08	0-0.09
1/8	0.10-0.11	0.11-0.125	0.09-0.10	0.10-0.11
15/100	0.12-0.15	0.14-0.15	0.11-0.12	0.12-0.13
2/10	0.16-0.19	0.18-0.20	0.13-0.16	0.14-0.17
1/4	0.20-0.23	0.22-0.25	0.17-0.20	0.18-0.22
3/10	0.24-0.30	0.27-0.30	0.21-0.24	0.23-0.26
4/10	0.32-0.39	0.35-0.40	0.25-0.32	0.27-0.35
1/2	0.40-0.47	0.44-0.50	0.33-0.40	0.36-0.43
6/10	0.48-0.60	0.53-0.60	0.41-0.48	0.44-0.52
8/10	0.64-0.79	0.70-0.80	0.49-0.64	0.53-0.70
1	0.80-0.89	0.87-0.97	0.65-0.80	0.71-0.87
1 1/8	0.90-0.99	0.98-1.08	0.81-0.90	0.88-0.98
1 1/4	1.00-1.11	1.09-1.21	0.91-1.00	0.99-1.09
1 1/10	1.12-1.19	1.22-1.30	1.01-1.12	1.10-1.22
1 1/2	1.20-1.27	1.31-1.39	1.13-1.20	1.23-1.30
1 9/10	1.28-1.43	1.40-1.56	1.21-1.28	1.31-1.39
1 8/10	1.44-1.59	1.57-1.73	1.29-1.44	1.40-1.57
2	1.60-1.79	1.74-1.95	1.45-1.60	1.58-1.74
2 1/4	1.80-1.99	1.96-2.17	1.61-1.80	1.75-1.96
2 1/2	2.00-2.23	2.18-2.43	1.81-2.00	1.97-2.17
2 9/10	2.24-2.39	2.44-2.60	2.01-2.24	2.18-2.43
3	2.40-2.55	2.61-2.78	2.25-2.40	2.44-2.60
3 1/10	2.56-2.79	2.79-3.04	2.41-2.56	2.61-2.78
3 1/2	2.80-3.19	3.05-3.47	2.57-2.80	2.79-3.04
4	3.20-3.59	3.48-3.91	2.81-3.20	3.05-3.48
4 1/2	3.60-3.99	3.92-4.34	3.21-3.60	3.49-3.91
5	4.00-4.47	4.35-4.86	3.61-4.00	3.92-4.35
5 8/10	4.48-4.79	4.87-5.21	4.01-4.48	4.36-4.87
6	4.80-4.99	5.22-5.43	4.49-4.80	4.88-5.22
6 1/4	5.00-5.59	5.44-6.08	4.81-5.00	5.23-5.43
7	5.60-5.99	6.09-6.52	5.01-5.60	5.44-6.09
7 1/2	6.00-6.39	6.53-6.95	5.61-6.00	6.10-6.52
8	6.40-7.19	6.96-7.82	6.01-6.40	6.53-6.96
9	7.20-7.99	7.83-8.69	6.41-7.20	6.97-7.83
10	8.00-9.59	8.70-10.00	7.21-8.00	7.84-8.70
12	9.60-11.99	10.44-12.00	8.01-9.60	8.71-10.43
15	12.00-13.99	13.05-15.00	9.61-12.00	10.44-13.04
17 1/2	14.00-15.99	15.22-17.39	12.01-14.00	13.05-15.21
20	16.00-19.99	17.40-20.00	14.01-16.00	15.22-17.39
25	20.00-23.99	21.74-25.00	16.01-20.00	17.40-21.74
30	24.00-27.99	26.09-30.00	20.01-24.00	21.75-26.09
35	28.00-31.99	30.44-34.78	24.01-28.00	26.10-30.43
40	32.00-35.99	34.79-39.12	28.01-32.00	30.44-37.78
45	36.00-39.99	39.13-43.47	32.01-36.00	37.79-39.13
50	40.00-47.99	43.48-50.00	36.01-40.00	39.14-43.48
60	48.00-55.99	52.17-60.00	40.01-48.00	43.49-52.17
70	56.00-59.99	60.87-65.21	48.01-56.00	52.18-60.87
75	60.00-63.99	65.22-69.56	56.01-60.00	60.88-65.22
80	64.00-71.99	69.57-78.25	60.01-64.00	65.23-69.57
90	72.00-79.99	78.26-86.95	64.01-72.00	69.58-78.26
100	80.00-87.99	86.96-95.64	72.01-80.00	78.27-86.96
110	88.00-99.99	95.65-108.69	80.01-88.00	86.97-95.65
125	100.00-119.99	108.70-125.00	88.01-100.00	95.66-108.70
150	120.00-139.99	131.30-150.00	100.01-120.00	108.71-130.43
175	140.00-159.99	152.17-173.90	120.01-140.00	130.44-152.17
200	160.00-179.99	173.91-195.64	140.01-160.00	152.18-173.91
225	180.00-199.99	195.65-217.38	160.01-180.00	173.92-195.62
250	200.00-239.99	217.39-250.00	180.01-200.00	195.63-217.39
300	240.00-279.99	260.87-300.00	200.01-240.00	217.40-260.87
350	280.00-319.99	304.35-347.82	240.01-280.00	260.88-304.35
400	320.00-359.99	347.83-391.29	280.01-320.00	304.36-347.83
450	360.00-399.99	391.30-434.77	320.01-360.00	347.84-391.30
500	400.00-479.99	434.78-500.00	360.01-400.00	391.31-434.78
600	480.00-600.00	521.74-600.00	400.01-480.00	434.79-521.74



Motor Protection White Paper

Download our white paper on motor protection at littelfuse.com/technicalcenter

MOTOR PROTECTION TABLES

Selection of Class RK5 Fuses (FLNR_ID / FLSR_ID / IDSR Series) or POWR-PRO® Class RK1 Fuses (LLNRK / LLSRK / LLSRK_ID Series) Based on Motor Horsepower

MOTOR HP	FULL LOAD AMPS	WITHOUT OVERLOAD RELAYS		WITH OVERLOAD RELAYS		SWITCH OR FUSE CLIP RATING
		S.F. = 1.15 OR MORE, TEMP RISE NOT OVER 40°C	S.F. = LESS THAN 1.15 OR TEMP RISE MORE THAN 40°C	S.F. = 1.15 OR MORE, TEMP RISE NOT OVER 40°C	S.F. = LESS THAN 1.15 OR TEMP RISE MORE THAN 40°C	
120 VOLT 1-PHASE MOTORS (120V CIRCUIT)						
1/8	4.4	5	5	5 ^{9/10}	5 ^{9/10}	30
1/4	5.8	7	6 ^{1/4}	7 ^{1/2}	7	30
3/8	7.2	9	8	9	9	30
1/2	9.8	12	10	15	12	30
3/4	13.8	15	15	17 ^{1/2}	17 ^{1/2}	30
1	16	20	17 ^{1/2}	20	20	30
1 1/2	20	25	20	25	25	30
2	24	30	25	30	30	30
230 VOLT 1-PHASE MOTORS (240V CIRCUIT)						
1/8	2.2	2 ^{1/2}	2 ^{1/2}	2 ^{9/10}	2 ^{9/10}	30
1/4	2.9	3 ^{1/2}	3 ^{1/2}	4	3 ^{1/2}	30
3/8	3.6	4 ^{1/2}	4	4 ^{1/2}	4 ^{1/2}	30
1/2	4.9	5 ^{9/10}	5 ^{9/10}	6 ^{1/4}	6	30
3/4	6.9	8	7 ^{1/2}	9	8	30
1	8	10	9	10	10	30
1 1/2	10	12	10	15	12	30
2	12	15	12	15	15	30
3	17	20	17 ^{1/2}	25	20	30
5	28	35	30*	35	35	60
7 1/2	40	50	45	50	50	60
10	50	60	50	70	60	60
200 VOLT 3-PHASE MOTORS (208V CIRCUIT)						
1/2	2.5	3	2 ^{9/10}	3 ^{1/10}	3	30
3/4	3.7	4 ^{1/2}	4	5	4 ^{1/2}	30
1	4.8	6	5 ^{9/10}	6 ^{1/4}	6	30
1 1/2	6.9	8	7 ^{1/2}	7 ^{1/2}	8	30
2	7.8	9	8	10	9	30
3	11	12	12	15	15	30
5	17.5	20	20	25	25	30
7 1/2	25.3	30*	25*	35	30*	60
10	32.2	40	35	45	40	60
15	48.3	60	50	70†	60	60
20	62.1	75	70	80	75	100
25	78.2	90	80	100	90	100
30	92	110	100*	125	110	200
40	120	150	125	150	150	200
50	150	175	150	200	175	200
60	177	200*	200*	225	225	400
75	221	250	250	300	300	400
100	285	350	300	400	350	400
125	359	400*	400*	450	450	600
150	414	500	450	600	500	600
230 VOLT 3-PHASE MOTORS (240V CIRCUIT)						
1/2	2.2	2 ^{9/10}	2 ^{1/2}	2 ^{9/10}	2 ^{9/10}	30
3/4	3.2	4	3 ^{1/2}	4	4	30
1	4.2	5	4 ^{1/2}	5 ^{9/10}	5	30
1 1/2	6.0	7 ^{1/2}	6 ^{1/4}	7 ^{1/2}	7 ^{1/2}	30
2	6.8	8	7 ^{1/2}	9	8	30
3	9.6	12	10	12	12	30
5	15.2	17 ^{1/2}	17 ^{1/2}	20	17 ^{1/2}	30
7 1/2	22	25	25	30	30	30
10	28	35	30*	35	35	60
15	42	50	45	60	50	60
20	54	60*	60*	70	70	100
25	68	80	75	90	80	100
30	80	100	90	100	100	100
40	104	125	110	150	125	200
50	130	150	150	175	150	200
60	154	175	175	200	200	200
75	192	225	200*	250	225	400
100	248	300	250	350	300	400
125	312	350	350	400	400	400
150	360	450	400*	450	450	600
200	480	600	500	600	600	600

MOTOR HP	FULL LOAD AMPS	WITHOUT OVERLOAD RELAYS		WITH OVERLOAD RELAYS		SWITCH OR FUSE CLIP RATING
		S.F. = 1.15 OR MORE, TEMP RISE NOT OVER 40°C	S.F. = LESS THAN 1.15 OR TEMP RISE MORE THAN 40°C	S.F. = 1.15 OR MORE, TEMP RISE NOT OVER 40°C	S.F. = LESS THAN 1.15 OR TEMP RISE MORE THAN 40°C	
460 VOLT 3-PHASE MOTORS (480V CIRCUIT)						
1/2	1.1	1 ^{1/10}	1 ^{1/4}	1 ^{1/10}	1 ^{1/10}	30
3/4	1.6	2	1 ^{9/10}	2	2	30
1	2.1	2 ^{1/2}	2 ^{1/4}	2 ^{9/10}	2 ^{1/2}	30
1 1/2	3.0	3 ^{1/2}	3 ^{3/10}	4	3 ^{1/2}	30
2	3.4	4	3 ^{1/2}	4 ^{1/2}	4	30
3	4.8	5 ^{9/10}	5	6	5 ^{9/10}	30
5	7.6	9	8	10	9	30
7 1/2	11	12	12	15	15	30
10	14	17 ^{1/2}	15	17 ^{1/2}	17 ^{1/2}	30
15	21	25	20	30	25	30
20	27	30*	30*	35	35	60
25	34	40	35	45	40	60
30	40	50	45	50	50	60
40	54	60*	60*	70	60*	100
50	65	80	70	90	75	100
60	77	90	80	100	90	100
75	96	110	110	125	125	200
100	124	150	125	175	150	200
125	156	175	175	200	200	200
150	180	225	200*	225	225	400
200	240	300	250	300	300	400
575 VOLT 3-PHASE MOTORS (600V CIRCUIT)						
1/2	0.9	1 ^{1/8}	1	1 ^{1/8}	1 ^{1/8}	30
3/4	1.3	1 ^{9/10}	1 ^{1/10}	1 ^{9/10}	1 ^{9/10}	30
1	1.7	2	1 ^{9/10}	2 ^{1/4}	2	30
1 1/2	2.4	3	2 ^{1/2}	3	3	30
2	2.7	3 ^{9/10}	2 ^{9/10}	3 ^{1/2}	3 ^{9/10}	30
3	3.9	4 ^{1/2}	4	5	4 ^{1/2}	30
5	6.1	7 ^{1/2}	7	8	7 ^{1/2}	30
7 1/2	9	10	10	12	12	30
10	11	12	12	15	15	30
15	17	20	17 ^{1/2}	25	20	30
20	22	25	25	30	30	30
25	27	30*	30*	35	35	60
30	32	40	35	40	40	60
40	41	50	45	60	50	60
50	52	60	60	70†	60	60
60	62	75	70	80	75	100
75	77	90	80	100	90	100
100	99	110	110	125	125	200
125	125	150	125	175	150	200
150	144	175	150	200	175	200
200	192	225	200*	250	225	400

NOTES

- S.F. = Motor Service Factor
- * Fuse Reducers Required
- † 100 Amp Switch Required



Motor Protection White Paper

Download our white paper on motor protection at littelfuse.com/technicalcenter

MOTOR PROTECTION TABLES

Selection of POWR-PRO® Class J Fuses (JTD_ID / JTD Series) Based on Motor Full Load Amps

MOTOR F.L.A.	JTD_ID / JTD AMPERE RATING	MOTOR F.L.A.	JTD_ID / JTD AMPERE RATING	MOTOR F.L.A.	JTD_ID / JTD AMPERE RATING
0.00 – 0.60	3/10	12.1 – 14.5	17 1/2	76.1 – 84.0	110
0.61 – 0.80	1	14.6 – 17.0	20	84.1 – 90.0	125
0.81 – 1.00	1 1/4	17.1 – 21.0	25	90.1 – 102	150
1.01 – 1.20	1 1/2	21.1 – 25.0	30	103 – 125	175
1.21 – 1.65	2	25.1 – 28.5	35	126 – 144	200
1.66 – 2.00	2 1/2	28.6 – 34.0	40	145 – 162	225
2.01 – 2.40	3	34.1 – 37.0	45	163 – 180	250
2.41 – 3.30	4	37.1 – 41.0	50	181 – 204	300
3.31 – 4.10	5	41.1 – 48.0	60	205 – 240	350
4.11 – 4.90	6	48.1 – 52.0	70	241 – 288	400
4.91 – 6.40	8	52.1 – 59.0	80	289 – 312	450
6.41 – 8.00	10	59.1 – 66.0	90	313 – 360	500
8.01 – 9.80	12	66.1 – 76.0	100	361 – 432	600
9.81 – 12.0	15				

NOTE: For severe motor starting conditions, fuses may be sized up to 225% motor F.L.A. (See NEC® Article 430.52 for Exceptions)

Selection of CCMR Time-Delay Fuses Based on Motor Full Load Amps

MOTOR FULL LOAD CURRENT (F.L.A.)						CCMR AMPERE RATING
FOR MOTORS WITH AN ACCELERATION TIME OF 2 SECONDS OR LESS		FOR MOTORS WITH AN ACCELERATION TIME OF 5 SECONDS OR LESS		FOR MOTORS WITH AN ACCELERATION TIME OF 8 SECONDS OR LESS		
MIN. F.L.A. (1)	MAX F.L.A. (3)	MIN. F.L.A. (1)	MAX F.L.A. (3)	MIN F.L.A. (2)	MAX F.L.A. (3)	
0.2	0.2	0.2	0.2	0.2	0.2	3/10
0.3	0.4	0.3	0.4	0.3	0.3	1/2
0.4	0.6	0.4	0.5	0.4	0.5	5/10
0.5	0.7	0.5	0.6	0.5	0.6	1
0.6	1.0	0.6	0.9	0.6	0.8	1 1/4
0.8	1.1	0.8	1.0	0.7	0.9	1 1/2
0.9	1.3	0.9	1.1	0.8	1.0	1 3/10
1.1	1.4	1.1	1.2	0.9	1.1	2
1.2	2.1	1.2	2.1	1.2	1.8	2 1/2
1.5	2.6	1.5	2.6	1.4	2.3	3
1.8	3.0	1.8	3.0	1.6	2.6	3 1/2
2.1	3.4	2.1	3.2	1.8	2.8	4
2.3	3.9	2.3	3.3	2.0	2.8	4 1/2
2.6	4.3	2.6	3.4	2.3	2.8	5
2.9	4.8	2.9	3.7	2.5	3.1	5 5/10
3.3	5.2	3.3	4.0	2.7	3.4	6
3.5	5.4	3.5	4.1	2.8	3.5	6 1/4
3.6	5.7	3.6	4.2	3.2	3.7	7
4.1	5.8	4.1	4.3	3.4	3.8	7 1/2
4.3	6.2	4.3	4.6	3.6	4.2	8
4.6	6.9	4.6	5.2	4.0	4.5	9
5.2	7.7	5.2	5.8	4.5	4.9	10
5.8	8.9	5.8	6.6	5.4	5.5	12
6.9	10.0	6.9	7.7	6.7	6.7	15
8.9	13.5	8.9	10.0	6.8	9.0	20
11.5	15.8	11.2 (2)	11.8	9.0	11.0	25
14.3	17.8	13.4 (2)	13.4	10.0	15.0	30
20.7	23.3	16.1	17.9	15.6	15.9	35
23.7	26.7	18.4	20.5	17.8	18.2	40
26.6	30.0	20.7	23.1	20.0	20.4	45
30.0	33.3	23.0	25.6	22.3	22.7	50
35.5	40.0	27.6	30.1	26.7	27.3	60

- 1 Based on NEC® requirement limiting the rating of time-delay fuses to 175% of motor F.L.A., or next higher rating.
- 2 Based on NEC® exception permitting fuse rating to be increased, but not to exceed, 225% motor F.L.A., however per NEC® Article 430.52 Class CC (0-30) fuses can now be sized up to 400% of motor F.L.A.
- 3 Based on Littelfuse CCMR time-delay characteristics.

NOTE: These values were calculated for motors with Locked Rotor Current (LRA), not exceeding the following values:

MOTOR F.L.A.	*LRA
0.00 – 1.00	850%
1.01 – 2.00	750%
2.01 – 10.0	650%
10.1 – 17.8	600%

*If motor LRA varies from these values, contact Littelfuse.

CONDENSED CROSS REFERENCE GUIDE

This cross reference covers the most popular fuses for which there is a similar Littelfuse standard item. Furnished for your convenience, it is meant to serve as a guide for product selection. We suggest you check all applicable specifications before making substitutions. For special applications, more complete information, and for fuse block and medium voltage fuse cross referencing, visit Littelfuse.com or call 1-800-TEC-FUSE (1-800-832-3873).



Competitor	Littelfuse	Competitor	Littelfuse	Competitor	Littelfuse	Competitor	Littelfuse
10KOTN	NLN	C519	229	JHC	JTD_ID	NOS	NLS
10KOTS	NLS	C520	225	JHL	LDFJ	NRN	NLN
50KOTN	NLN	CHSF	L50QS	JJN	JLLN	NRN (15-60A)	NLKP
50KOTS	NLS	CJ	JLS	JJS	JLLS	NRS	NLS
170M	PSR	CJS	JLS	JKS	JLS	OT	NLN
A013F	L15S	CLF	KLPC or KLLU	KAA	L15S	OTM	BLF or BLN
A015F	L15S	CLL	KLLU or KLPC	KAB	L25S	OTN	NLN
A015R	L15S	CLU	KLLU or KLPC	KAC	KLC	OTS	NLS
A025F	L25S	CM	BLF	KBH	L50S	PC_UD	PSR
A050F	L50S	CRN-R	FLNR_ID †	KLM	KLKD	PSC	PSR
A060F	L60S	CRS-R	FLSR_ID	KLU	KLLU or KLPC	PV-(1-30)A10F	SPF
A070F	L70S	CTN-R	KLNR	KN	KLNR	PV-(50A-200A)1XL15	SPNH
A13X	L15S	CTS-R	KLSR	KON	NLN	REN	FLNR †
A25X	L25S †	DCT	SPF †	KOS	NLS	RES	FLSR †
A2D-R	LLNRK ‡	DFJ	LDFJ	KRP-C	KLPC	RF	FLNR †
A2K-R	KLNR	EBS	BLS	KS	KLSR	RFA	L15S
A3T	JLLN	ECNR	FLNR_ID †	KTK	KLK	RFC	KLC
A4BQ	KLPC	ECSR	FLSR_ID	KTKR	KLKR	RFL (750V)	L70S (700 V)
A4BT	KLLU or KLPC	ERN	FLNR †	KTNR	KLNR	RFN (Mersen)	FLNR †
A4BY	KLPC or KLLU	ERS	FLSR †	KTSR	KLSR	RFS (Mersen)	FLSR †
A4J	JLS	FNA	FLA	KTU 601-2000A	LDC	RFV	L50S
A50P (type 1 & 4)	L50S	FNM	FLM	KTU 2500-6000A	KLPC	RHN	KLNR
A50QS	L50QS	FNQ	FLQ	LCL	KLPC or KLLU	RHS	KLSR
A60X	L60S	FNQ-R	KLDR	LCU	LDC	S	S00
A6D-R	LLSRK_ID ‡	FRN-R	FLNR_ID †	LENRK	LLNRK	SA	SAO
A6K-R	KLSR	FRS-R	FLSR_ID	LESRK	LLSRK_ID	SC	SLC
A6T	JLLS	FWA	L15S †§	LKU	KLLU	SEC	SLC
A70P	L70S	FWH	L50QS	LONRK	LLNRK	SF13X	L15S
A70QS	L70QS	FWP	L70QS	LOSRK	LLSRK_ID	SF25X	L25S
ABC	314	FWX	L25S * †	LPCC	CCMR	SF50P	L50S
ACK	CCK	GDA	216	LPJ (SP)	JTD_ID	SF60X	L60S
AG	SLC	GDB	217	LPNRK (SP)	LLNRK ‡	SF70P	L70S
AGA	AGA	GDC	218	LPSRK (SP)	LLSRK_ID	SFE	SFE
AGC	312	GDL	313	MCL	KLK	SL	SLO
AGU (1-30A)	BLN	GEB	LEB	MCR	251	T	TOO
AGW	AGW	GEBN	LET	MDA	326	TJN	JLLN
AJT	JTD_ID	GFA	251	MDL	313	TJS	JLLS
AMG	MEG	GFN	FLA	MDQ	313	TL	TLO
AMI	MID	GGC	312	MDV	315	TR	FLNR_ID †/§
ANL	CNL ‡	GGM	235	MDX	313	TRM	FLM
ANN	CNN_E	GLR	LGR	MEN	FLM	TRN-R	FLNR_ID †/§
ASO	SPF	GMA	235	MEQ	FLQ	TRS	FLSR_ID ‡
ATC	ATO (287)	GMD	239	MID	FLA	TRS-R	FLSR_ID ‡
AT-DE	FLNR_ID †	GMT	481	MOF	BLN	XL25X	L25S
ATDR	CCMR ‡	HCLR	KLKR	MOL	BLF	XL50F	L50S *
ATM (Mersen)	KLKD	HCTR	KLDR	MTH	312	XL70F	L70S *
ATMR	KLKR ‡	HEB	LEB	NCLR	KLNR		
ATQ	FLQ	HET	LET	NON	NLN		
ATQR	KLDR	HLR	LHR				
AX	481	HP10M	SPF				
A_UD	PSR	HP6J	SPFJ *				
BAF	BLF	HSJ	LDFJ				
BAN	BLN	JDL	JTD_ID				
BBS	BLS	JFL	JLS				

A fuse may be used in circuits where the fuse's voltage rating is equal to or greater than the circuit voltage, unless otherwise stated on the fuse. For example, the FLSR_ID indicating fuse has a voltage rating of 75-600 volts. This fuse can be used on 600 volts, 480 volts, 250 volts, 125 volts, or 75 volts. Never use a fuse in a circuit having a higher rated voltage than the fuse.

* Check specific mounting dimensions before substituting.

† Check characteristics and dimensions for application before substituting.

‡ For 1/16 - 30 amperes, order non-indicating FLNR series fuses.

§ Verify voltage for DC applications.

+ Littelfuse product is a non-renewable fuse.

ALPHANUMERIC INDEX

Product Name	Page Number
097023	122
150322	131
1LFS Series	121
215 Series	35
216 Series	35
217 Series	35
218 Series	35
224 Series	34
225 Series	34
229 Series	34
230 Series	34
235 Series	35
239 Series	35
251 Series	33
273 Series	33
287 Series	36
297 Series	36
299 Series	36
312 Series	34
313 Series	34
314 Series	34
315 Series	34
318 Series	34
324 Series	34
325 Series	34
326 Series	34
342 Series	125
345 Series	126
354 Series	121
451 Series	33
477 Series	33
481 Series	51
505 Series	33
571 Series	117
572 Series	117
ATO Series	36
BLF Series	30
BLN Series	30
BLS Series	31
Box Cover Units	167
Bus Bar Series	119
BVSP Series	164
Cable Limiters	67
CCMR Series	27
Class CC	27
Class CD	27
Class G	26
Class J	21
Class K5	20
Class L	8
Class RK1	13
Class RK5	16
Class T	24
CNL Series	64

Product Name	Page Number
CNN / CNN_E Series	64
Coordination Panels	155
Cylindrical Fuses	68
Definitions	184
Displays	169
Distribution Blocks	130
E-Rated Fuses	42
Electronic Fuses	32
FBDIN1	110
FLA Series	31
FLM Series	30
FLNR Series	17
FLNR_ID Series	17
FLQ Series	30
FLSR Series	17
FLSR_ID Series	17
FLU Series	31
Fork-Lift Fuses	64
FRCK Series	168
Fuse Blocks, Fuse Holders	90
Fuse Classifications	182
Fuse Reducers	166
Fuseology	171
GDB Series	137
GFP	122
HAZGARD™	64
High-Speed Fuses	70
IDSR Series	16
In-Line Fuse Holders	148
JCASE Series	37
JLLN Series	24
JLLS Series	24
JLS Series	22
JTD/JTD_ID Series	21
KLC Series	81
KLDR Series	28
KLK Series	30
KLKD Series	30
KLKR Series	28
KLLU Series	9
KLNR Series	15
KLPC Series	8
KLQ Series	31
KLSR Series	15
L15S Series	85
L17T Series	50
L25S Series	81
L50QS Series	75
L50S Series	81
L60030C, L60030M Series	107
L60030MPCB	103
L60S Series	81
L70QS Series	78
L70S Series	83

Product Name	Page Number
LCC Series	122
LCP Series	155
LD Series	130
LDC Series	10
LEB Series	148
LEC Series	148
LET Series	148
LEX Series	148
LEX YY Series	152
LEXT YY Series	152
LEY Series	148
LF Series Covers	111
LFC600	107
LFCL Series	67
LFFB003	123
LFG480, LFG600 Series	105
LFH250, LFH600 Series	94
LFJ 1000V Series	114
LFJ600 Series	91
LFNH	60
LFPSJ	118
LFPXV	113
LFR250, LFR600 Series	91
LFT300, LFT600 Series	100
LGR Series	66
LHFB	123
LHR Series	66
Live Parts	48
LLNRK Series	13
LLSRK/LLSRK_ID Series	13
LMF Series	66
LPBC Series	130
LPFP	122
LPS	157
LPSC	117
LPSM	117
LPSM-QC	120
LPXV Series	112
LRU Series	166
LS Series	130
LSCR Series	127
LSCY	167
LSKA	167
LSOU	167
LSOW	167
LSOX	167
LSOY	167
LSOY-B	167
LSRU	167
LSRW	167
LSRX	167
LSRY	167
LSSU	167
LSSW	167

ALPHANUMERIC INDEX

Product Name	Page Number
LSSX	167
LSSY	167
LSTY	167
LTFD Series	55
LVSP Series	163
MAXI Series	36
Medium Voltage	39
MEGA Series	65
MFP	122
Midget Fuses	30
MINI Series	36
MOV	161
MROplus	3
NLKP Series	20
NLN Series	20
NLS Series	20
OEM Products	69
Overvoltage Suppression	161

Product Name	Page Number
Plug Fuses	65
Potential Transformer	47
POWR-BLOKS™	130
POWR-PRO® Fuses	3
Pre-Engineered Solutions	154
PSR Series	171
R-Rated Fuses	40
Semiconductor Fuses	70
SLC Series	26
Solar Fuses	56
SPF Series	62
SPFI Series	61
SPFJ Series	63
SPL001	110
Splicer Blocks	130
SPNH Series	60
SPXI Series	59
SPXV Series	58

Product Name	Page Number
Stud-Mounted Fuse Blocks	127
Suppression Products	160
Technical Information	170
Telecom Fuses	49
TLN Series	51
TLO Series	65
TLS Series	52
TMOV	162
TOO Series	65
Varistors	162
WPB Series	149

Local Resources for a **GLOBAL** Market

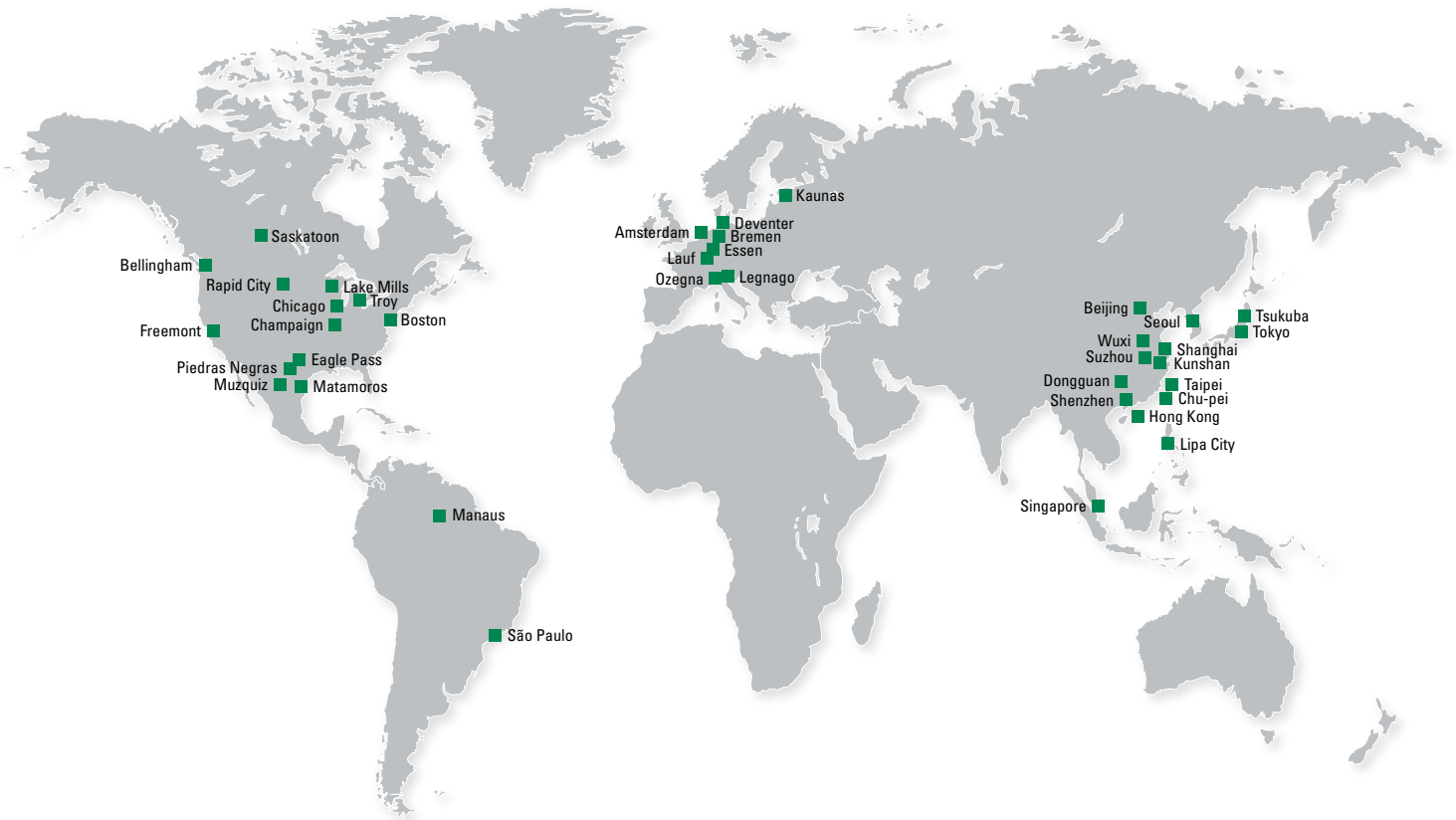

Protection Relays & Controls Catalog (PF130N)

The comprehensive line of electronic and microprocessor-based protection relays, timers, and flashers safeguard equipment and personnel to prevent expensive damage, downtime or injury due to electrical faults.

POWR-GARD® Solar Catalog (PF140N)

POWR-GARD Solar Products are designed specifically for photovoltaic applications where issues such as heat, efficiency, longevity and global standards impact the choices in selecting circuit protection.



Visit Technical Resources at Littelfuse.com

Technical information is only a click away. The Littelfuse Technical Resources contains datasheets, product manuals, whitepapers, application guides, demos, on-line design tools, and more.

An Extension of Your Team



Technical Hotline (800-TEC-FUSE or 800-832-3873)

Littelfuse engineers are a phone call away to help identify potential issues and provide product recommendations to resolve problems.

Application and Field Support

Our experienced product and application engineers work step-by-step with customers from design to installation to determine the best solution.



Littelfuse World Headquarters

8755 West Higgins Road, Suite 500
Chicago, IL 60631, USA

Technical Support:

Tel: +1-800-TEC-FUSE
E-mail: techline@littelfuse.com

Customer Service:

Tel: +1-800-227-0029
E-mail: PG_CSG@littelfuse.com
Fax: +1-847-787-5190

Littelfuse SymCom

222 Disk Drive
Rapid City, SD 57701, USA

Technical Support:

Tel: +1-800-832-3873
E-mail: techline@littelfuse.com

Customer Service:

Tel: +1-800-227-0029
E-mail: PG_CSG@littelfuse.com
Fax: +1-605-348-5685

Littelfuse Startco

3714 Kinneer Place
Saskatoon, SK S7P 0A6

Canada

Tel: +1-306-373-5505
Fax: +1-306-374-2245
E-mail: techline@littelfuse.com



Littelfuse products are certified to many standards around the world. To check certifications on specific product please refer to the product datasheet on Littelfuse.com.

Specifications, descriptions and illustrative material in this literature are as accurate as known at the time of publication, but are subject to changes without notice. Visit Littelfuse.com for the most up-to-date technical information.

Disclaimer Notice – Information furnished is believed to be accurate and reliable. However, users should independently evaluate the suitability of and test each product selected for their own applications. Littelfuse products are not designed for, and may not be used in, all applications. **Read complete Disclaimer Notice at www.littelfuse.com/product-disclaimer.**