

NOTES:

- FOR WAVESOLDERING (SOLDER BATH TEMPERATURE 265°C FOR 8 SEC. AND SOLDER PREHEAT 150°C FOR 180 SEC.)
- IP RATING: IP67
- SEALED TO WITHSTAND PRESSURE UP TO 1,45 PSI FOR 30 MINUTES AFTER HIGH TEMPERATURE EXPOSURE
- METALSHELL: ZINC DIE CAST;
min. 50µin NICKEL PLATING over COPPER
- INSULATORS: PBT GF UL 94 V-0; GREEN
- O-RING: SILICONE PER ASTM D2000 70 SHORE A
- SEALING COMPOUND: EPOXY RESIN UL 94 V-0; BLACK
- SIGNAL CONTACTS: COPPER ALLOY;
PLATING (SEE PART NO.):
30µin HARD GOLD over min. 50µin NICKEL if 1□ in PART NO.
GOLD FLASH over NICKEL if 3□ in PART NO.
- HIGH POWER CONTACTS 20A: COPPER ALLOY;
PLATING, MATING SIDE (SEE PART NO.):
□ PLEASE ADD 1 for 30µin HARD GOLD over min. 50µin NICKEL
□ PLEASE ADD 3 for GOLD FLASH over NICKEL
PLATING, TERMINATION SIDE: 160-240µin TIN over 80µin NICKEL
- METAL BRACKETS: ZINC DIE CAST;
300µin COOPER/40-120µin NICKEL/120-200µin TIN
- WASHERS: COPPER ALLOY; 80µin NICKEL
- P.C.B. SNAPS: COPPER ALLOY; min. 200µin TIN over 80µin NICKEL
PCB HOLE: $\phi 3,1 \pm 0,1$; PCB THICKNESS 1,6mm
- HEXLOCKING SCREWS: STAINLESS STEEL
- P.C.B. HOLE DRILLINGS and RECOMMENDED PANEL CUT-OUT ON SHEET 2
- RECOMMENDED TORQUE FOR MOUNTING SCREW 35Ncm (3.1 in.LB) / max.67Ncm (6 in.LB)
- CONNECTOR IS PART MARKED: $\boxed{15-00570 \square \text{ CONEC } ABC}$ (see note 9)

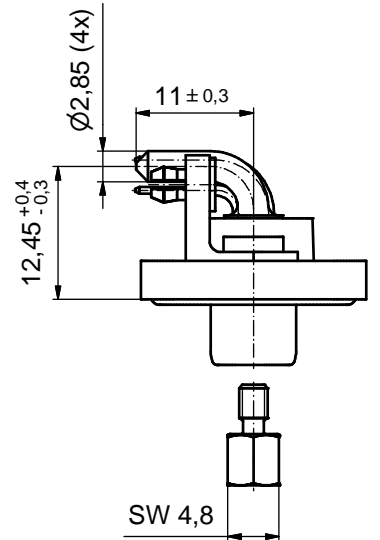
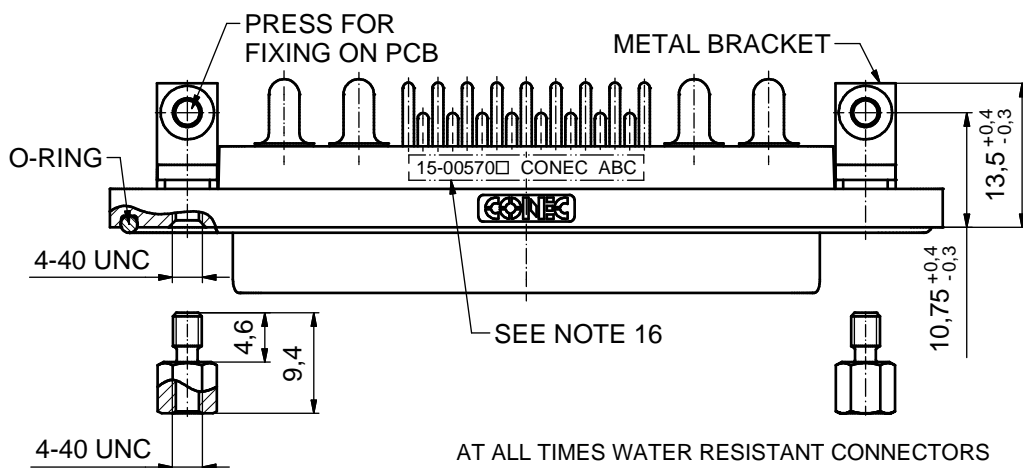
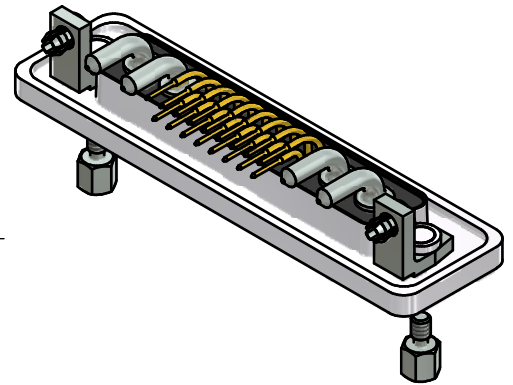
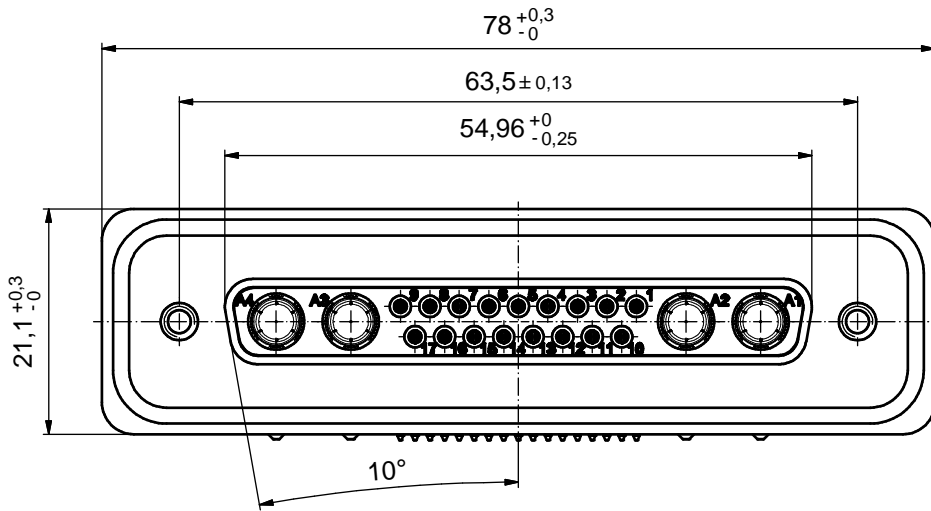
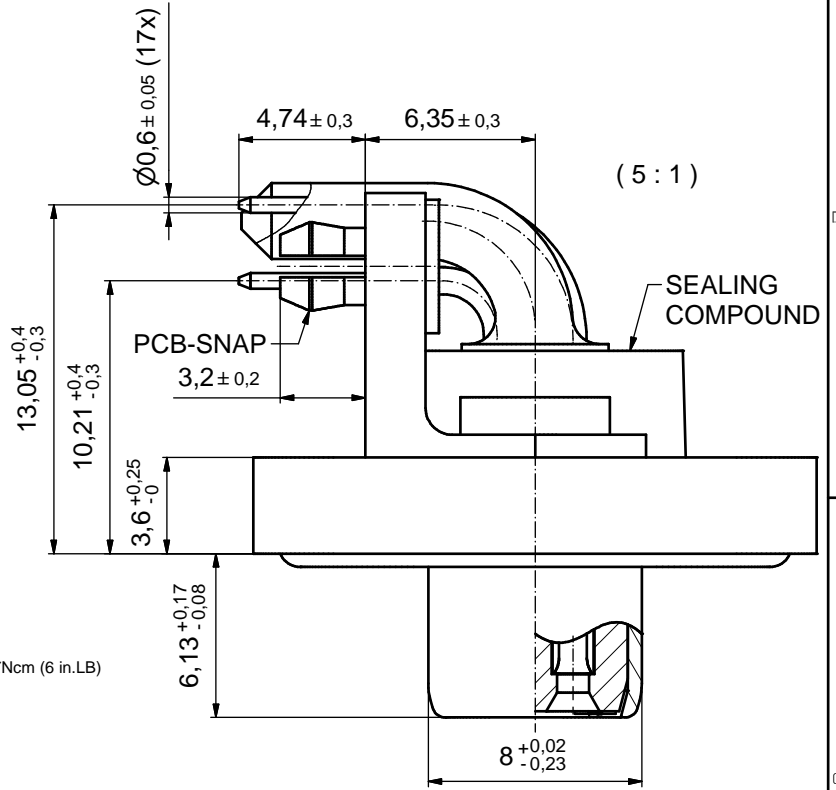

AT ALL TIMES WATER RESISTANT CONNECTORS NOT IN USE SHOULD BE COVERED WITH A CONEC WATER RESISTANT CAP OR WATER TIGHT HOOD.

Directive 2002/95/EC RoHS compliant

THIS DRAWING MAY NOT BE COPIED OR REPRODUCED IN ANY WAY, AND MAY NOT BE PASSED ON TO A THIRD PARTY WITHOUT WRITTEN PERMISSION. OWNERSHIP AND COPYRIGHT OF CONEC GmbH DO NOT ALTER CAD DRAWING BY HAND	tolerance		dim. in mm		scale: 2:1 (5:1)	
					material: SEE NOTES	
	date	name	drawn	07.04.14	title: D-SUB COMBINATION FEMALE 90°	
	appd.	07.04.14	Schmidt		21WA4S SOLDER PIN ANGLED	
	norm				with metal bracket, hexlocking screw and snap	
d-old				dwg no: 15K1A1468		
a	Original			DIN-A3		
rev.	description	date	name	sh: 1		
CONEC				part no: 15-00570□ (see note 9)		

P.C.B. HOLE DRILLINGS
(P.C.B. TOP SIDE)

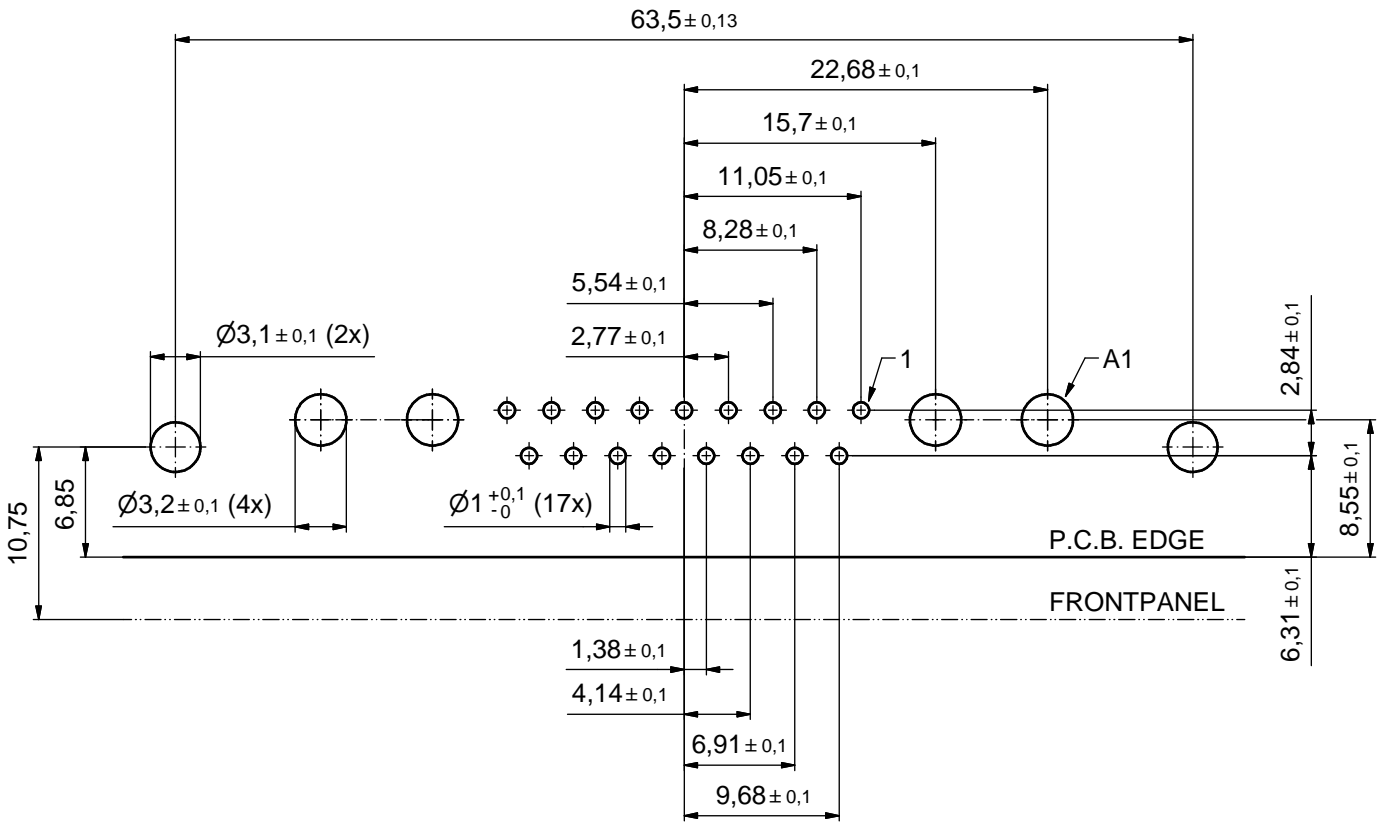

RECOMMENDED PANEL CUT-OUT

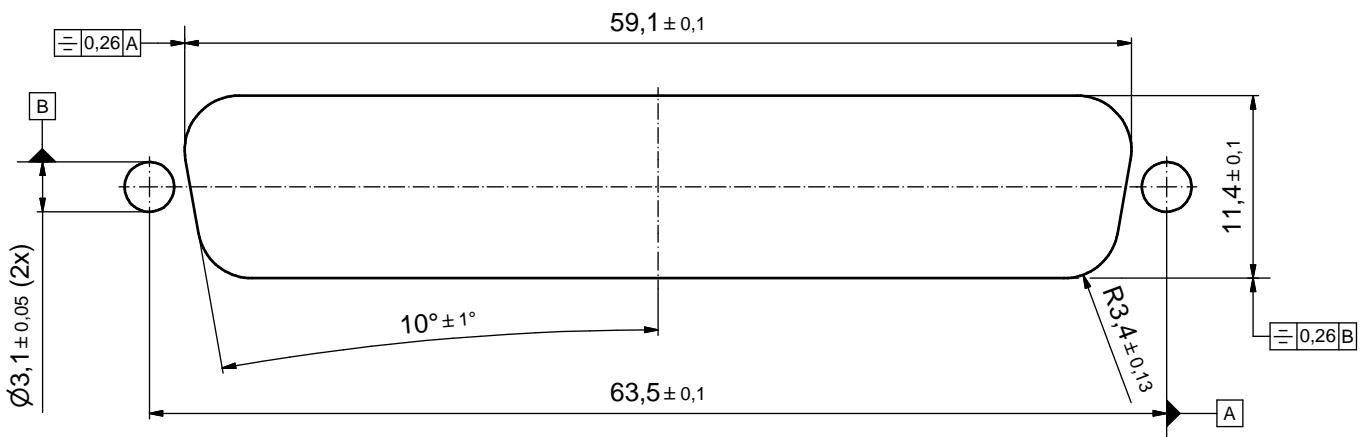

THIS DRAWING MAY NOT BE COPIED OR REPRODUCED IN ANY WAY, AND MAY NOT BE PASSED ON TO A THIRD PARTY WITHOUT WRITTEN PERMISSION. OWNERSHIP AND COPYRIGHT OF CONEC GmbH DO NOT ALTER CAD DRAWING BY HAND				tolerance		scale: 3:1
				dim. in mm		material: SEE SHEET 1
	drawn	07.04.14	Lehmenkühler	title:		
	appd.	07.04.14	Schmidt	P.C.B. HOLE DRILLINGS		
	norm			RECOMMENDED PANEL CUT-OUT		
	d-old			D-SUB Combination Female 90° 21WA4S		
	rev.	a	Original	CONEC®		dwg no: 15K1A1468
description					part no: SEE SHEET 1	sh: 2