

SN54AS885, SN74AS885 8-BIT MAGNITUDE COMPARATORS

SDAS236A – DECEMBER 1982 – REVISED JANUARY 1995

- Latchable P-Input Ports With Power-Up Clear
- Choice of Logical or Arithmetic (Two's Complement) Comparison
- Data and PLE Inputs Utilize pnp Input Transistors to Reduce dc Loading Effects
- Approximately 35% Improvement in ac Performance Over Schottky TTL While Performing More Functions
- Cascadable to n Bits While Maintaining High Performance
- 10% Less Power Than STTL for an 8-Bit Comparison
- Package Options Include Plastic Small-Outline (DW) Packages, Ceramic Chip Carriers (FK), and Standard Plastic (NT) and Ceramic (JT) 300-mil DIPs

description

These advanced Schottky devices are capable of performing high-speed arithmetic or logic comparisons on two 8-bit binary or two's complement words. Two fully decoded decisions about words P and Q are externally available at two outputs. These devices are fully expandable to any number of bits without external gates. To compare words of longer lengths, the P > QOUT and P < QOUT outputs of a stage handling less significant bits can be connected to the P > QIN and P < QIN inputs of the next stage handling more significant bits. The cascading paths are implemented with only a two-gate-level delay to reduce overall comparison times for long words. Two alternative methods of cascading are shown in *application information*.

The latch is transparent when P latch-enable (PLE) input is high; the P-input port is latched when PLE is low. This provides the designer with temporary storage for the P-data word. The enable circuitry is implemented with minimal delay times to enhance performance when cascaded for longer words. The PLE, P, and Q data inputs utilize pnp input transistors to reduce the low-level current input requirement to typically -0.25 mA, which minimizes dc loading effects.

The SN54AS885 is characterized for operation over the full military temperature range of -55°C to 125°C. The SN74AS885 is characterized for operation from 0°C to 70°C.

SN54AS885 . . . JT PACKAGE
SN74AS885 . . . DW OR NT PACKAGE
(TOP VIEW)

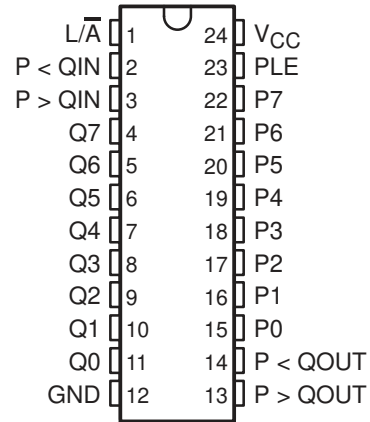

SN54AS885 . . . FK PACKAGE
(TOP VIEW)

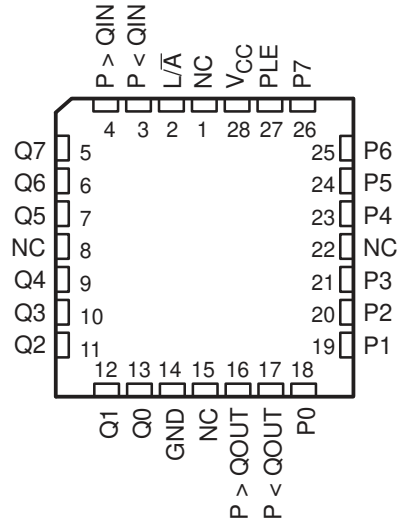

NC – No internal connection

SN54AS885, SN74AS885 8-BIT MAGNITUDE COMPARATORS

SDAS236A – DECEMBER 1982 – REVISED JANUARY 1995

FUNCTION TABLE

COMPARISON	INPUTS				OUTPUTS	
	$\overline{L/A}$	DATA P0–P7, Q0–Q7	P > QIN	P < QIN	P > QOUT	P < QOUT
Logical	H	P > Q	X	X	H	L
Logical	H	P < Q	X	X	L	H
Logical†	H	P = Q	H or L	H or L	H or L	H or L
Arithmetic	L	P AG Q	X	X	H	L
Arithmetic	L	Q AG P	X	X	L	H
Arithmetic†	L	P = Q	H or L	H or L	H or L	H or L

† In these cases, P > QOUT follows P > QIN and P < QOUT follows P < QIN.
AG = arithmetically greater than

logic symbol‡

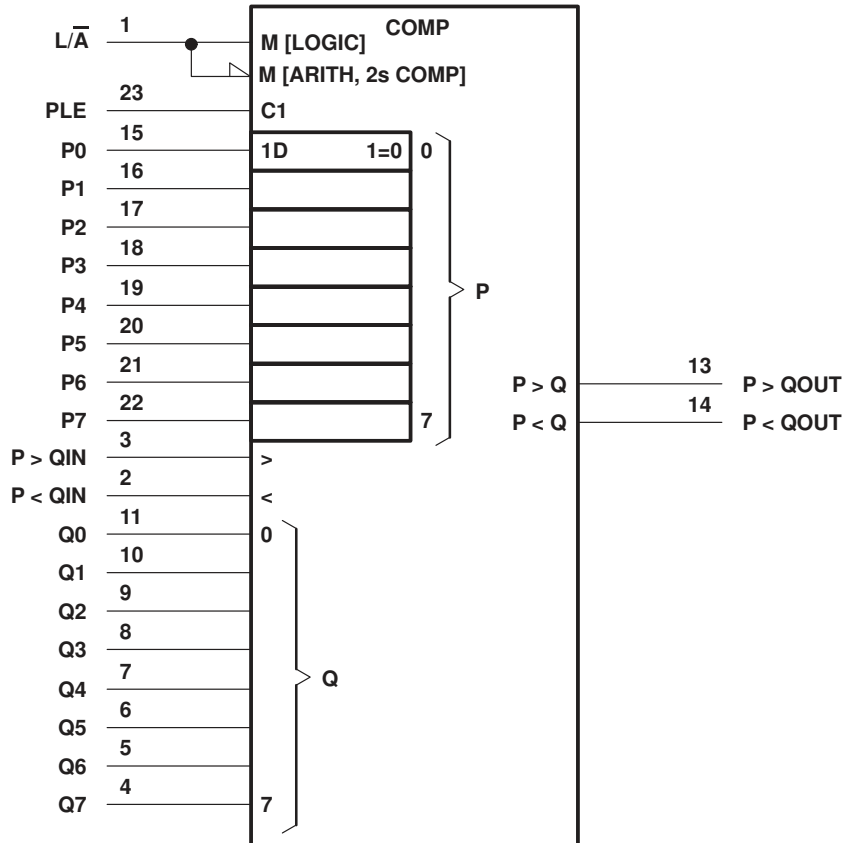

‡ This symbol is in accordance with ANSI/IEEE Std 91-1984 and IEC Publication 617-12.
Pin numbers shown are for the DW, JT, and NT packages.

SN54AS885, SN74AS885 8-BIT MAGNITUDE COMPARATORS

SDAS236A – DECEMBER 1982 – REVISED JANUARY 1995

logic diagram (positive logic)

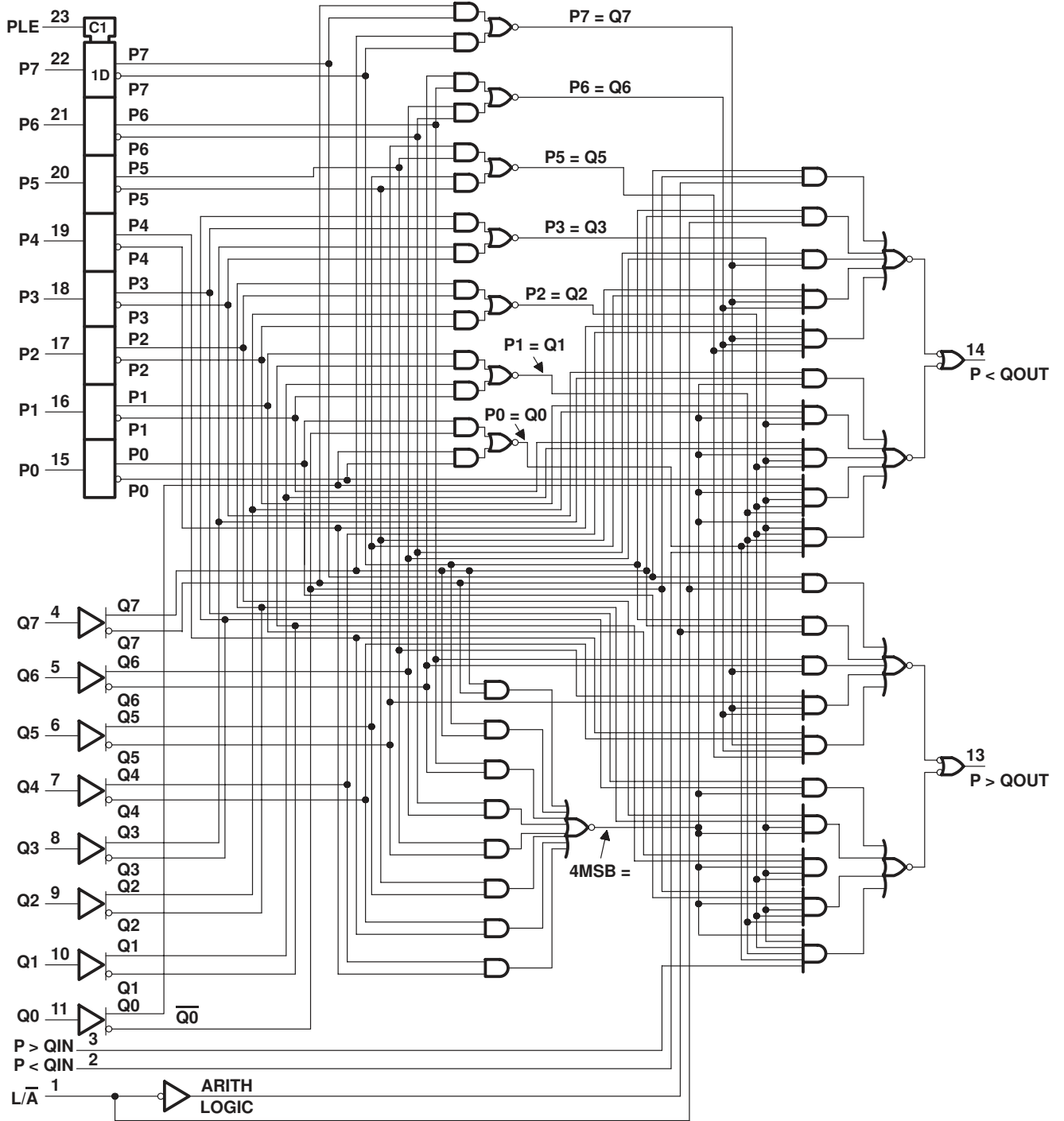

Pin numbers shown are for the DW, JT, and NT packages.

SN54AS885, SN74AS885 8-BIT MAGNITUDE COMPARATORS

SDAS236A – DECEMBER 1982 – REVISED JANUARY 1995

absolute maximum ratings over operating free-air temperature range (unless otherwise noted)†

Supply voltage, V_{CC}	7 V
Input voltage, V_I	7 V
Operating free-air temperature range, T_A : SN54AS885	-55°C to 125°C
SN74AS885	0°C to 70°C
Storage temperature range	-65°C to 150°C

† Stresses beyond those listed under “absolute maximum ratings” may cause permanent damage to the device. These are stress ratings only, and functional operation of the device at these or any other conditions beyond those indicated under “recommended operating conditions” is not implied. Exposure to absolute-maximum-rated conditions for extended periods may affect device reliability.

recommended operating conditions

	SN54AS885			SN74AS885			UNIT
	MIN	NOM	MAX	MIN	NOM	MAX	
V_{CC} Supply voltage	4.5	5	5.5	4.5	5	5.5	V
V_{IH} High-level input voltage	2			2			V
V_{IL} Low-level input voltage			0.8			0.8	V
I_{OH} High-level output current			-2			-2	mA
I_{OL} Low-level output current			20			20	mA
t_{su}^* Setup time, data before PLE↓	2			2			ns
t_h^* Hold time, data after PLE↓	4.5			4			ns
T_A Operating free-air temperature	-55		125	0		70	°C

* On products compliant to MIL-STD-883, Class B, this parameter is based on characterization data but is not production tested.

electrical characteristics over recommended operating free-air temperature range (unless otherwise noted)

PARAMETER	TEST CONDITIONS	SN54AS885			SN74AS885			UNIT
		MIN	TYP‡	MAX	MIN	TYP‡	MAX	
V_{IK}	$V_{CC} = 4.5 V$, $I_I = -18 mA$			-1.2			-1.2	V
V_{OH}	$V_{CC} = 4.5 V$ to $5.5 V$, $I_{OH} = -2 mA$	$V_{CC} - 2$			$V_{CC} - 2$			V
V_{OL}	$V_{CC} = 4.5 V$, $I_{OL} = 20 mA$	0.35	0.5		0.35	0.5		V
I_I	$V_{CC} = 5.5 V$, $V_I = 7 V$		0.1			0.1		mA
I_{IH}	L/\bar{A}		40			40		μA
	Others		20			20		
I_{IL}	L/\bar{A}		-4			-4		mA
	$P > QIN, P < QIN$		-2			-2		
	P, Q, PLE		-1			-1		
I_{O}^{\S}	$V_{CC} = 5.5 V$, $V_O = 2.25 V$	-20		-112	-20		-112	mA
I_{CC}	$V_{CC} = 5.5 V$, See Note 1		130	210		130	210	mA

‡ All typical values are at $V_{CC} = 5 V$, $T_A = 25^\circ C$.

§ The output conditions have been chosen to produce a current that closely approximates one half of the true short-circuit output current, I_{OS} .

NOTE 1: I_{CC} is measured with all inputs high except L/\bar{A} , which is low.



switching characteristics (see Figure 3)

PARAMETER	FROM (INPUT)	TO (OUTPUT)	V _{CC} = 4.5 V to 5.5 V, C _L = 50 pF, R _L = 500 Ω, T _A = MIN to MAX						UNIT
			SN54AS885			SN74AS885			
			MIN	TYP†	MAX	MIN	TYP†	MAX	
t _{PLH}	L/ \bar{A}	P < QOUT, P > QOUT	2	8.5	14	1	8.5	13	ns
t _{PHL}			2	7.5	14	1	7.5	13	
t _{PLH}	P < QIN, P > QIN	P < QOUT, P > QOUT	2	5	10	1	5	8	ns
t _{PHL}			2	5.5	10	1	5.5	8	
t _{PLH}	Any P or Q data input	P < QOUT, P > QOUT	2	13.5	21	1	13.5	17.5	ns
t _{PHL}			2	10	17	1	10	15	

† All typical values are at V_{CC} = 5 V, T_A = 25°C.

APPLICATION INFORMATION

The 'AS885 can be cascaded to compare words longer than eight bits. Figure 1 shows the comparison of two 32-bit words; however, the design is expandable to n bits. Figure 1 shows the optimum cascading arrangement for comparing words of 32 bits or greater. Typical delay times shown are at V_{CC} = 5 V, T_A = 25°C and use the standard advanced Schottky load of R_L = 500 Ω, C_L = 50 pF.

Figure 2 shows the fastest cascading arrangement for comparing 16-bit or 24-bit words. Typical delay times shown are at V_{CC} = 5 V, T_A = 25°C and use the standard advanced Schottky load of R_L = 500 Ω, C_L = 50 pF.

SN54AS885, SN74AS885 8-BIT MAGNITUDE COMPARATORS

SDAS236A – DECEMBER 1982 – REVISED JANUARY 1995

APPLICATION INFORMATION

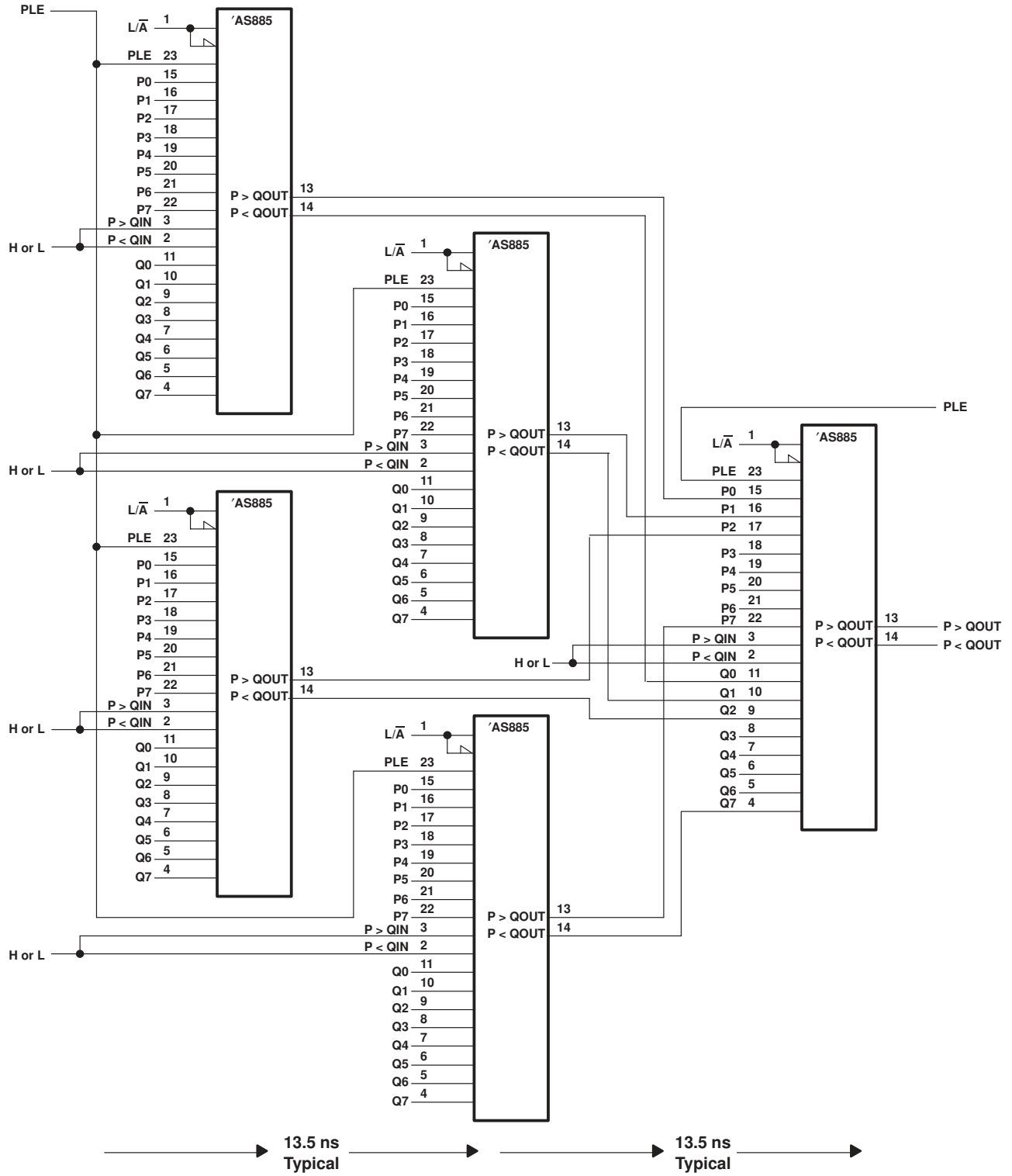

Figure 1. 32-Bit to 72 (n)-Bit Magnitude Comparator

APPLICATION INFORMATION

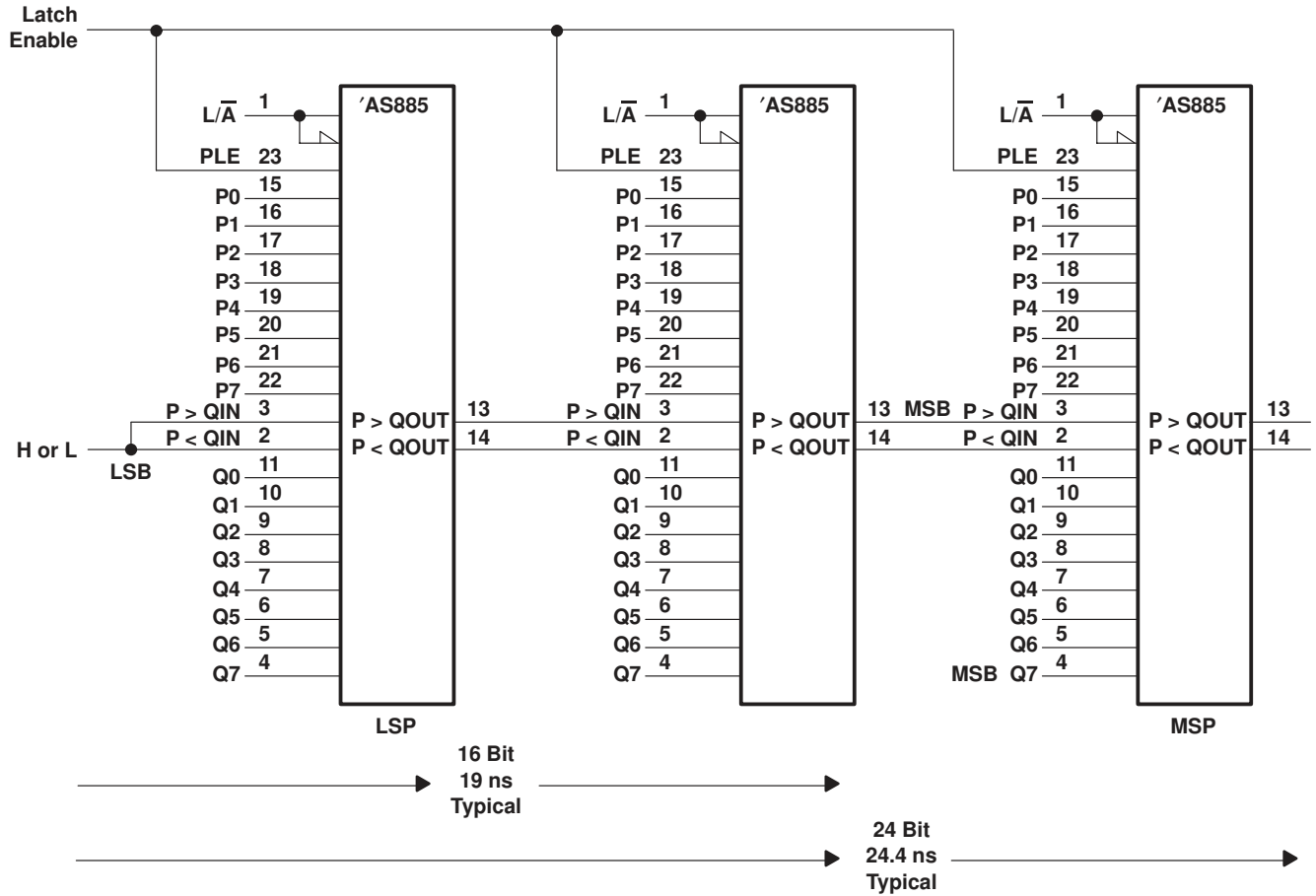
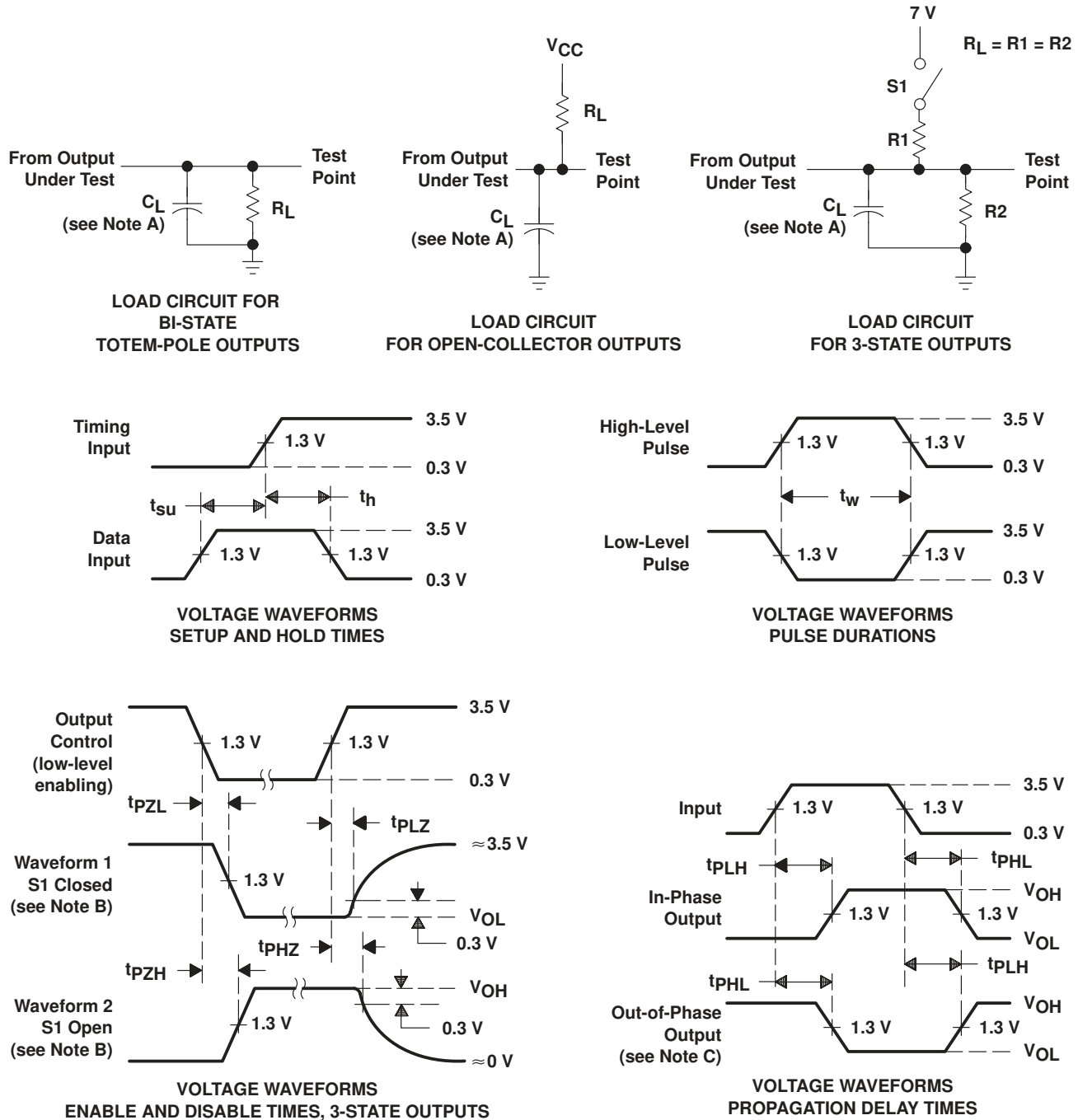

Figure 2. Fastest Cascading Arrangement for Comparing 16-Bit or 24-Bit Words

SN54AS885, SN74AS885 8-BIT MAGNITUDE COMPARATORS

SDAS236A – DECEMBER 1982 – REVISED JANUARY 1995

PARAMETER MEASUREMENT INFORMATION SERIES 54ALS/74ALS AND 54AS/74AS DEVICES



- NOTES: A. C_L includes probe and jig capacitance.
 B. Waveform 1 is for an output with internal conditions such that the output is low except when disabled by the output control. Waveform 2 is for an output with internal conditions such that the output is high except when disabled by the output control.
 C. When measuring propagation delay items of 3-state outputs, switch S1 is open.
 D. All input pulses have the following characteristics: $PRR \leq 1$ MHz, $t_r = t_f = 2$ ns, duty cycle = 50%.
 E. The outputs are measured one at a time with one transition per measurement.

Figure 3. Load Circuits and Voltage Waveforms

PACKAGING INFORMATION

Orderable Device	Status (1)	Package Type	Package Drawing	Pins	Package Qty	Eco Plan (2)	Lead/Ball Finish (6)	MSL Peak Temp (3)	Op Temp (°C)	Device Marking (4/5)	Samples
5962-89757013A	ACTIVE	LCCC	FK	28	1	TBD	POST-PLATE	N / A for Pkg Type	-55 to 125	5962-89757013A SNJ54AS 885FK	Samples
5962-8975701LA	ACTIVE	CDIP	JT	24	1	TBD	Call TI	N / A for Pkg Type	-55 to 125	5962-8975701LA SNJ54AS885JT	Samples
SN54AS885JT	ACTIVE	CDIP	JT	24	1	TBD	Call TI	N / A for Pkg Type	-55 to 125	SN54AS885JT	Samples
SN74AS885DW	ACTIVE	SOIC	DW	24	25	Green (RoHS & no Sb/Br)	NIPDAU	Level-1-260C-UNLIM	0 to 70	AS885	Samples
SNJ54AS885FK	ACTIVE	LCCC	FK	28	1	TBD	POST-PLATE	N / A for Pkg Type	-55 to 125	5962-89757013A SNJ54AS 885FK	Samples
SNJ54AS885JT	ACTIVE	CDIP	JT	24	1	TBD	Call TI	N / A for Pkg Type	-55 to 125	5962-8975701LA SNJ54AS885JT	Samples

(1) The marketing status values are defined as follows:

ACTIVE: Product device recommended for new designs.

LIFEBUY: TI has announced that the device will be discontinued, and a lifetime-buy period is in effect.

NRND: Not recommended for new designs. Device is in production to support existing customers, but TI does not recommend using this part in a new design.

PREVIEW: Device has been announced but is not in production. Samples may or may not be available.

OBSELETE: TI has discontinued the production of the device.

(2) **RoHS:** TI defines "RoHS" to mean semiconductor products that are compliant with the current EU RoHS requirements for all 10 RoHS substances, including the requirement that RoHS substance do not exceed 0.1% by weight in homogeneous materials. Where designed to be soldered at high temperatures, "RoHS" products are suitable for use in specified lead-free processes. TI may reference these types of products as "Pb-Free".

RoHS Exempt: TI defines "RoHS Exempt" to mean products that contain lead but are compliant with EU RoHS pursuant to a specific EU RoHS exemption.

Green: TI defines "Green" to mean the content of Chlorine (Cl) and Bromine (Br) based flame retardants meet JS709B low halogen requirements of <=1000ppm threshold. Antimony trioxide based flame retardants must also meet the <=1000ppm threshold requirement.

(3) MSL, Peak Temp. - The Moisture Sensitivity Level rating according to the JEDEC industry standard classifications, and peak solder temperature.

(4) There may be additional marking, which relates to the logo, the lot trace code information, or the environmental category on the device.

(5) Multiple Device Markings will be inside parentheses. Only one Device Marking contained in parentheses and separated by a "~" will appear on a device. If a line is indented then it is a continuation of the previous line and the two combined represent the entire Device Marking for that device.

(6) Lead/Ball Finish - Orderable Devices may have multiple material finish options. Finish options are separated by a vertical ruled line. Lead/Ball Finish values may wrap to two lines if the finish value exceeds the maximum column width.

Important Information and Disclaimer:The information provided on this page represents TI's knowledge and belief as of the date that it is provided. TI bases its knowledge and belief on information provided by third parties, and makes no representation or warranty as to the accuracy of such information. Efforts are underway to better integrate information from third parties. TI has taken and continues to take reasonable steps to provide representative and accurate information but may not have conducted destructive testing or chemical analysis on incoming materials and chemicals. TI and TI suppliers consider certain information to be proprietary, and thus CAS numbers and other limited information may not be available for release.

In no event shall TI's liability arising out of such information exceed the total purchase price of the TI part(s) at issue in this document sold by TI to Customer on an annual basis.

OTHER QUALIFIED VERSIONS OF SN54AS885, SN74AS885 :

- Catalog: [SN74AS885](#)
- Military: [SN54AS885](#)

NOTE: Qualified Version Definitions:

- Catalog - TI's standard catalog product
- Military - QML certified for Military and Defense Applications

JT (R-GDIP-T**)

CERAMIC DUAL-IN-LINE

24 LEADS SHOWN

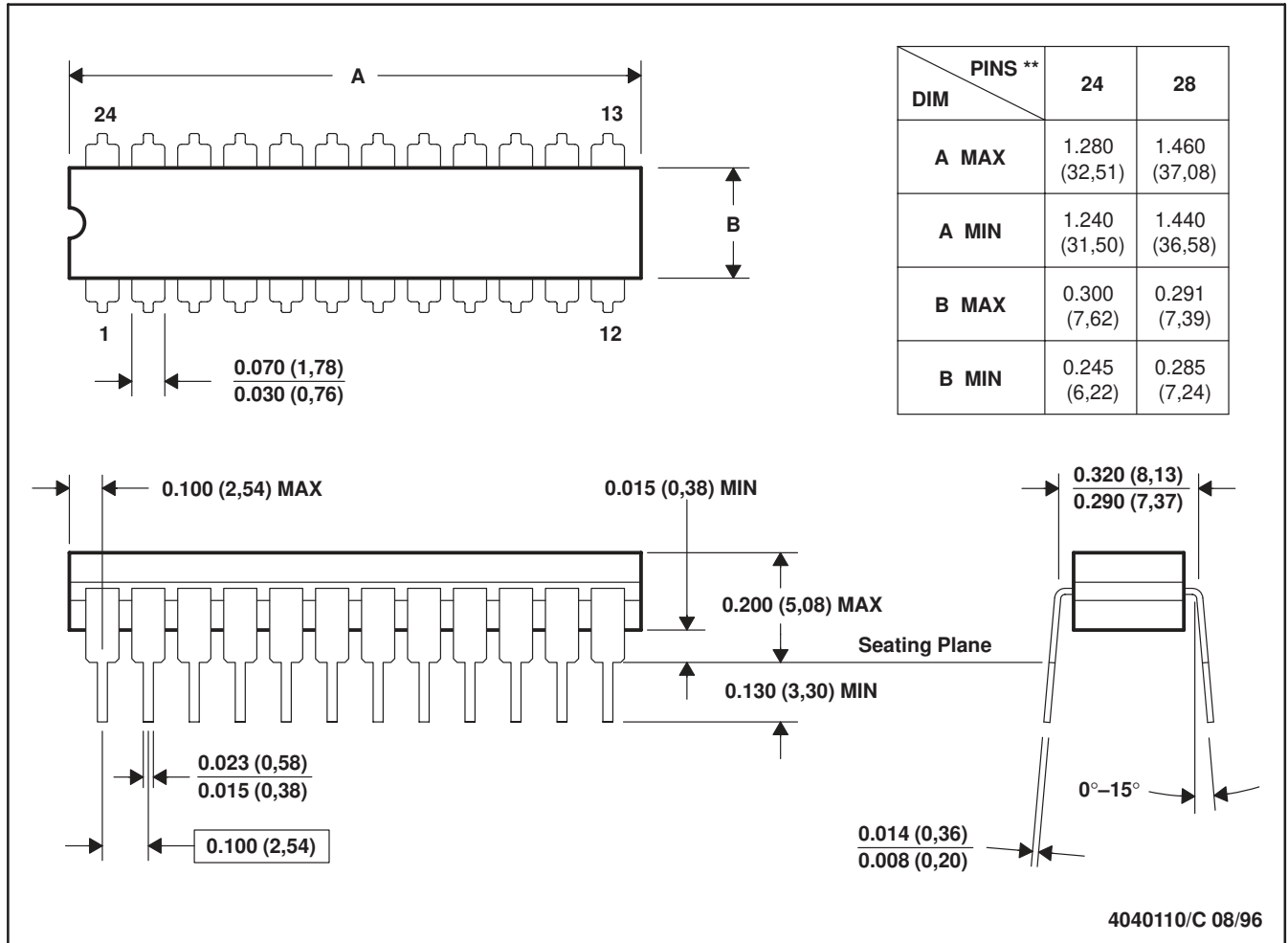

- NOTES: A. All linear dimensions are in inches (millimeters).
 B. This drawing is subject to change without notice.
 C. This package can be hermetically sealed with a ceramic lid using glass frit.
 D. Index point is provided on cap for terminal identification.
 E. Falls within MIL STD 1835 GDIP3-T24, GDIP4-T28, and JEDEC MO-058 AA, MO-058 AB

FK (S-CQCC-N**)

LEADLESS CERAMIC CHIP CARRIER

28 TERMINAL SHOWN



NO. OF TERMINALS **	A		B	
	MIN	MAX	MIN	MAX
20	0.342 (8,69)	0.358 (9,09)	0.307 (7,80)	0.358 (9,09)
28	0.442 (11,23)	0.458 (11,63)	0.406 (10,31)	0.458 (11,63)
44	0.640 (16,26)	0.660 (16,76)	0.495 (12,58)	0.560 (14,22)
52	0.740 (18,78)	0.761 (19,32)	0.495 (12,58)	0.560 (14,22)
68	0.938 (23,83)	0.962 (24,43)	0.850 (21,6)	0.858 (21,8)
84	1.141 (28,99)	1.165 (29,59)	1.047 (26,6)	1.063 (27,0)



4040140/D 01/11

- NOTES:
- All linear dimensions are in inches (millimeters).
 - This drawing is subject to change without notice.
 - This package can be hermetically sealed with a metal lid.
 - Falls within JEDEC MS-004

DW (R-PDSO-G24)

PLASTIC SMALL OUTLINE

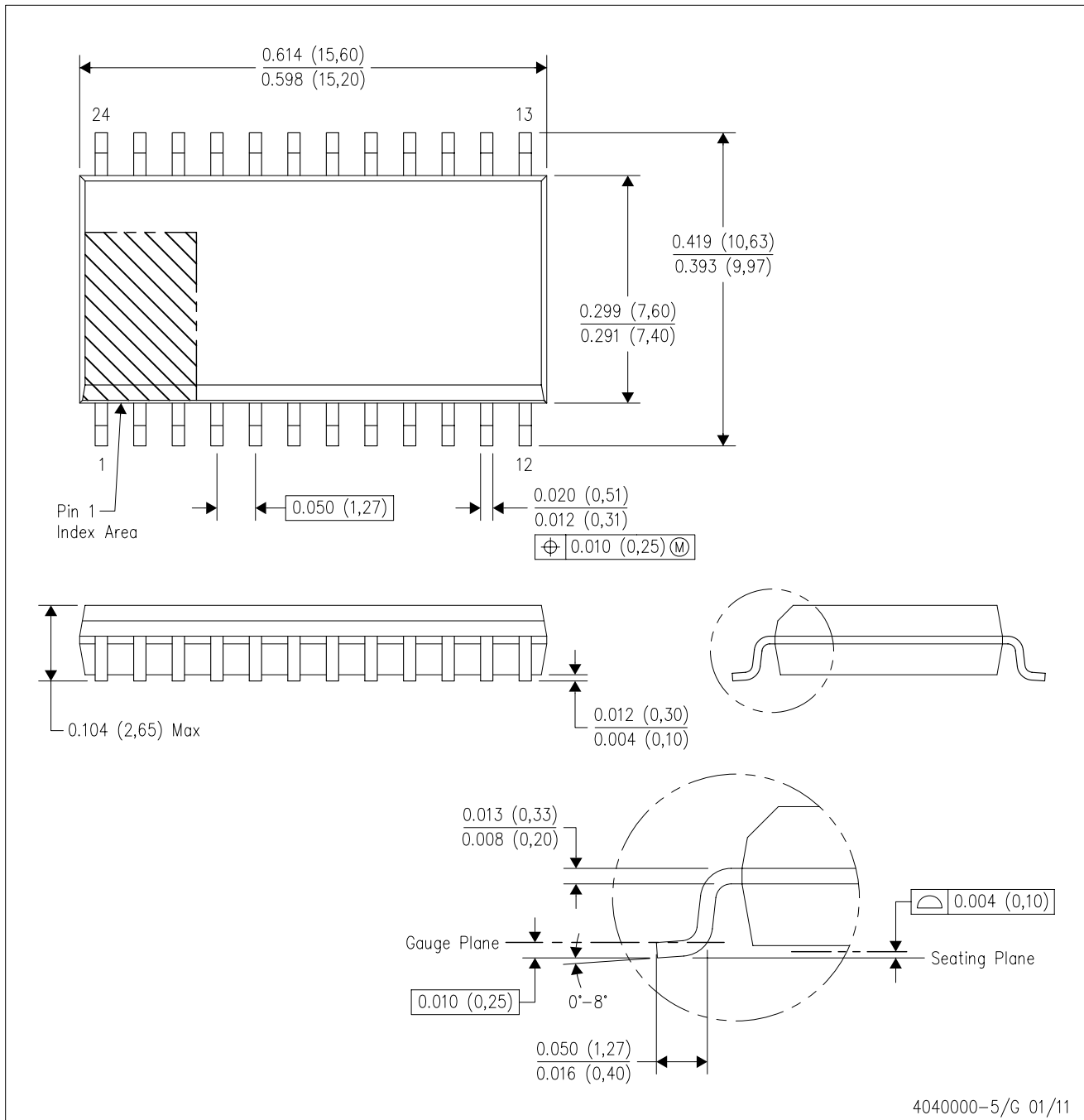

- NOTES:
- A. All linear dimensions are in inches (millimeters). Dimensioning and tolerancing per ASME Y14.5M-1994.
 - B. This drawing is subject to change without notice.
 - C. Body dimensions do not include mold flash or protrusion not to exceed 0.006 (0,15).
 - D. Falls within JEDEC MS-013 variation AD.

IMPORTANT NOTICE AND DISCLAIMER

TI PROVIDES TECHNICAL AND RELIABILITY DATA (INCLUDING DATASHEETS), DESIGN RESOURCES (INCLUDING REFERENCE DESIGNS), APPLICATION OR OTHER DESIGN ADVICE, WEB TOOLS, SAFETY INFORMATION, AND OTHER RESOURCES "AS IS" AND WITH ALL FAULTS, AND DISCLAIMS ALL WARRANTIES, EXPRESS AND IMPLIED, INCLUDING WITHOUT LIMITATION ANY IMPLIED WARRANTIES OF MERCHANTABILITY, FITNESS FOR A PARTICULAR PURPOSE OR NON-INFRINGEMENT OF THIRD PARTY INTELLECTUAL PROPERTY RIGHTS.

These resources are intended for skilled developers designing with TI products. You are solely responsible for (1) selecting the appropriate TI products for your application, (2) designing, validating and testing your application, and (3) ensuring your application meets applicable standards, and any other safety, security, or other requirements. These resources are subject to change without notice. TI grants you permission to use these resources only for development of an application that uses the TI products described in the resource. Other reproduction and display of these resources is prohibited. No license is granted to any other TI intellectual property right or to any third party intellectual property right. TI disclaims responsibility for, and you will fully indemnify TI and its representatives against, any claims, damages, costs, losses, and liabilities arising out of your use of these resources.

TI's products are provided subject to TI's Terms of Sale (www.ti.com/legal/termsofsale.html) or other applicable terms available either on ti.com or provided in conjunction with such TI products. TI's provision of these resources does not expand or otherwise alter TI's applicable warranties or warranty disclaimers for TI products.

Mailing Address: Texas Instruments, Post Office Box 655303, Dallas, Texas 75265
Copyright © 2020, Texas Instruments Incorporated