



Atmel LED Driver-MSL3085

8-string White and RGB LED Driver with Adaptive Power Control, EEPROM, and I²C/SMBus Serial Interface

Datasheet Brief



Atmel LED Driver-MSL3085

8-string White and RGB LED Driver with Adaptive Power Control, EEPROM, and I²C/SMBus Serial Interface

General Description

The Atmel LED Driver-MSL3085 compact, high-power 8 LED strings controller uses external MOSFETs to sink up to 350mA per string, with current accuracy and matching better than $\pm 1.5\%$. The MSL3085 drives eight parallel strings of LEDs, and offers fault detection and management of open and short circuit LEDs.

The MSL3085 features a 1MHz I²C serial interface. The interface supports video frame-by-frame LED string intensity control for up to eight interconnected devices, allowing active area dimming and phase shifted PWM timing for video displays. It includes an advanced PWM engine that synchronizes LED timing with the video signal for reduced motion blur and waterfall noise.

The MSL3085 adaptively controls the DC-DC converters that power the LED strings using patented Atmel Adaptive SourcePower™ technology. These fault monitored efficiency optimizers minimize power use while maintaining LED current accuracy, and allow up to eight interconnected devices to automatically negotiate the optimum power supply voltage.

A unique combination of peak current control and pulse width dimming management offers simple full-screen brightness control, versatile area dimming, and a consistent white point. LED string current is set for each string using a current sense (FET source) resistor. LED current is also digitally controlled for all eight LED strings. Global string drive pulse width is adjusted with an 8-bit global intensity register, and individual string pulse width is modulated with 12-bit control.

The MSL3085 monitors for string open circuit, LED short circuit, loss-of-sync and over temperature faults, and provides a hardware fault output to notify the MCU. Detailed fault status and control are available through the serial interface. Additionally, the MSL3085 includes an on-chip EEPROM that allows the power-up default register settings to be customized via the serial interface.

The MSL3085 is offered in a 6 x 6 x 0.75mm, 40-pin TQFN package, and operates over a -40°C to +105°C temperature range.

Applications

Long Life, Efficient LED Backlighting for:

- Televisions and Desktop Monitors
- Medical and Industrial Instrumentation
- Automotive Audio-visual Displays

Channel Signs

Architectural Lighting

Ordering Information

| EIGHT-CHANNEL LED STRING DRIVER | | |
|---------------------------------|------------------|-----------------------------|
| PART | INTERFACE | PACKAGE |
| MSL3085BT | I ² C | 40-pin, 6 x 6 x 0.75mm TQFN |

Atmel LED Driver-MSL3085

8-string White and RGB LED Driver with Adaptive Power Control, EEPROM, and I²C/SMBus Serial Interface

Key Features

- 12-bit PWM String Dimming
- Fast, 1MHz I²C Serial Interface Supports up to Eight Devices per Bus
- 8-bit Adaptive Power Correction Maximizes Efficiency of up to Two String Power Supplies
- Multiple MSL3085s Share String Power Supplies and Automatically Negotiate the Optimum Supply Voltage
- External MOSFETs for high Voltage and/or Current
- Drives up to Eight Parallel LED Strings
- Supports Adaptive, Real-time Area Dimming for Highest Dynamic Range in LCD TVs and Monitors
- Programmable String Phase Reduces Motion Blur and Improves Efficiency
- Global Intensity Control via Serial Interface
- $\pm 1.5\%$ Current Accuracy and Current Balance
- Video Frame (VSYNC) and Line (HSYNC) Sync Inputs
- Sync Loss Detectors Optionally Disable LED Strings
- EEPROM Saves Power-on Default Settings
- LED Open Circuit and Short Circuit Fault Detection
- Individual Fault Detection Enable for Each String
- Over-temperature Shut-Off Protection
- Broadcast Write Simplifies Configuration
- -40°C To $+105^{\circ}\text{C}$ Operating Temperature Range

Application Circuit

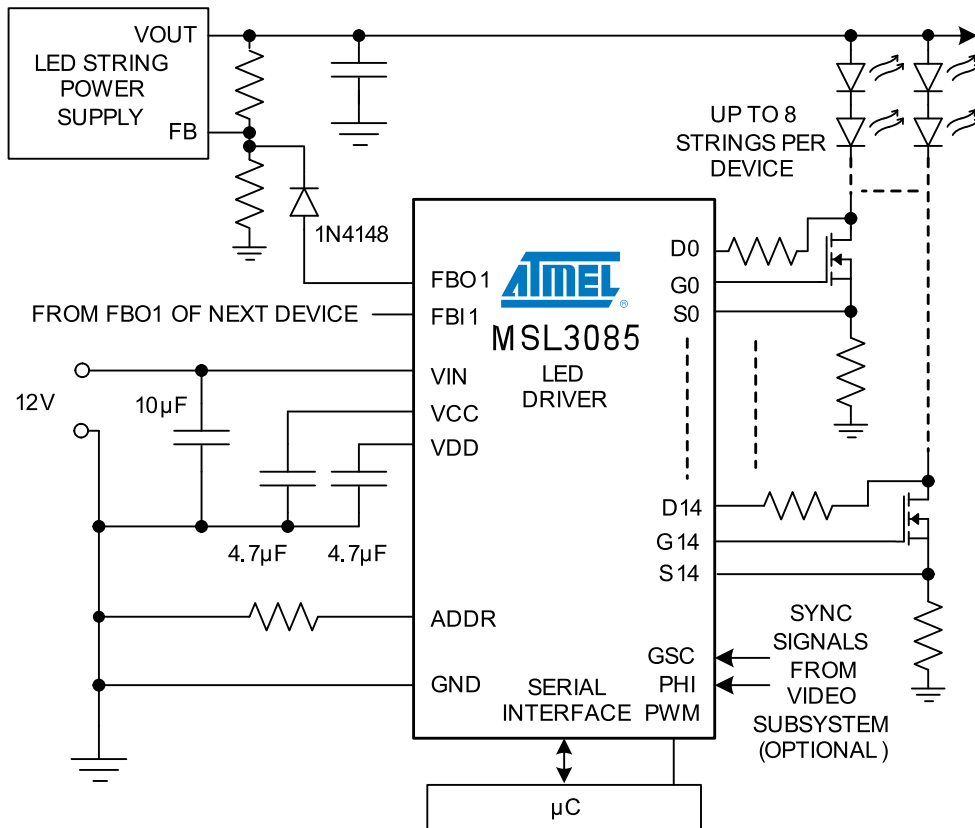



Atmel LED Driver MSL3085 Overview

The MSL3085 controls eight strings of series-connected LEDs at up to 350mA per string. Eight MSL3085s can share a serial interface. The MSL3085 FET gate drive output is optimized for FETs requiring no more than 10nC of charge. The MSL3085 PWM engine generates the PWM signal that drives the strings, or optionally accepts an external PWM signal.

LED Power Supplies and Efficiency Optimizers

The MSL3085 features two efficiency optimizer outputs that dynamically adjust the LED string power supplies to their minimum voltage necessary to drive the LED strings, while assuring accurate LED current flow. One of the efficiency optimizers features an input that allows up to eight devices to be connected in a chain configuration. When implemented, the chain automatically negotiates, controls, and optimizes the string power supply for all LED strings driven by the chain.

The power supplies can use any topology, and are typically DC-DC boost converters. The efficiency optimizers rely on close matching of the LEDs connected to a string supply. The better the matching, the better the overall efficiency.

Timing, PWM, Intensity Controls and Synchronization

The PWM LED drive signals synchronize to video frame timing via the PHI input, and to pixel timing via the GSC input. Area LED dimming is supported for contrast and color gamut improvement. With area dimming, motion blur is reduced by setting each LED string's PWM phasing to synchronize string off times with the LCD update timing. The MSL3085 also includes internal PWM timing generation for standalone (non-video) LED lighting applications. Table 1 presents the available methods of LED intensity control.

Table 1. LED Intensity Controls

| LED INTENSITY CONTROL | EFFECT | REGISTER | RESOLUTION |
|---|--|--|------------|
| Global LED string current adjust | Reduces string current globally from maximum set by FET source resistors | ISTR (0x31) | 8 bits |
| Global LED string PWM | Global PWM scaling | GINT (0x2F) and ALTGINT (0x30) | 8 bits |
| Individual LED string PWM | PWM individual string control | PWMn (0x60 thru 0x7D) and ALTPWMn (0xA0 thru 0xBD) | 12 bits |
| External resistor from FET source to ground | Sets maximum individual string current | - | - |
| External PWM input | Optionally controls all string PWM drives | - | - |

Atmel LED Driver-MSL3085

8-string White and RGB LED Driver with Adaptive Power Control, EEPROM, and I²C/SMBus Serial Interface

Package Pin-out

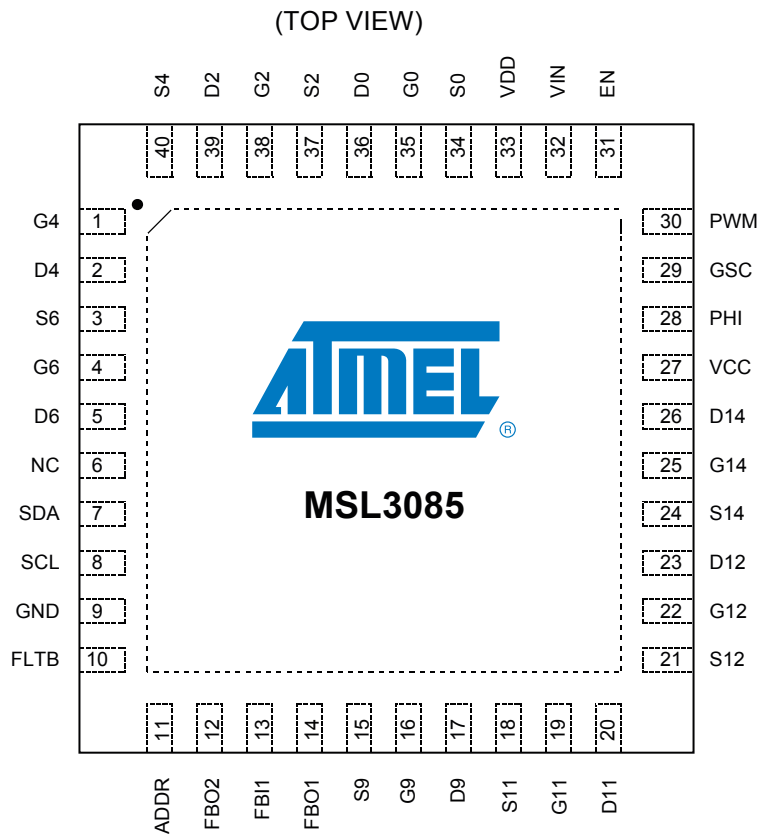

Figure 1. Atmel LED Driver-MSL3085 Pin-out, 40-pin TQFN.

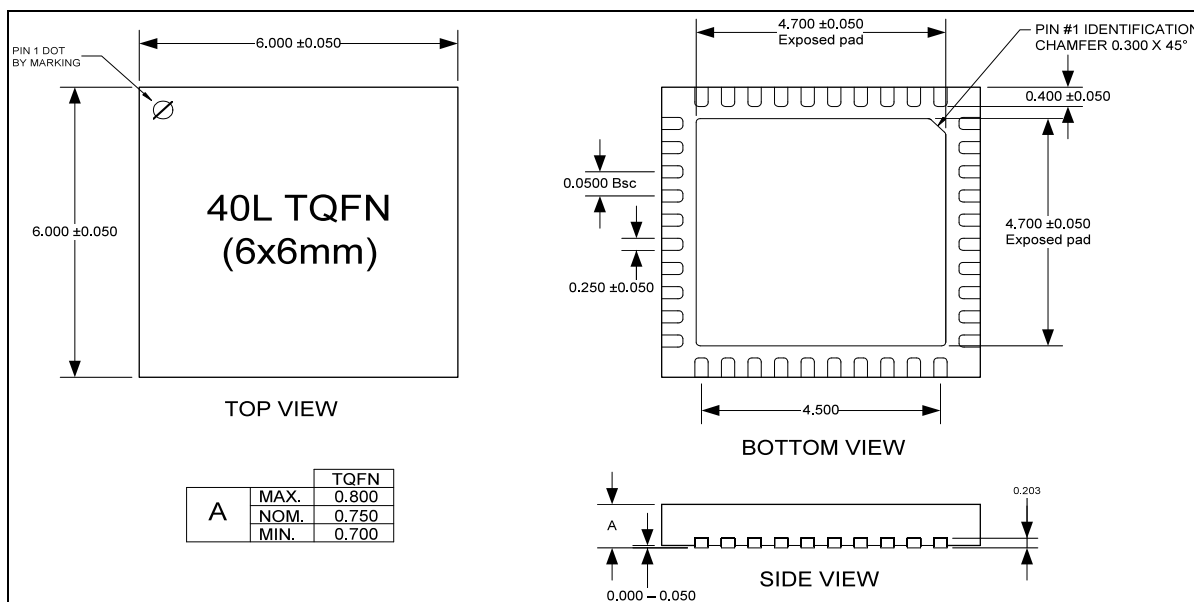

Figure 2. Package Dimensions: 40-pin, 6mm x 6mm x 0.75mm TQFN (0.5mm pin pitch) with Exposed Pad.



Pin Descriptions

NOTE: To ensure register compatibility with the 16-string device of the same family (Atmel LED Driver-MSL2161), pin names for gate, drain and source connections are not sequential.

| PIN | PIN NAME | PIN DESCRIPTION |
|-----|----------|--|
| 1 | G4 | Gate output 4 Gate drive output for external MOSFET 4. Connect G4 to the gate of the external MOSFET driving LED string 4. |
| 2 | D4 | Drain sense input 4 Drain sense input for external MOSFET 4. Connect D4 through a 10MΩ resistor to the drain of the external MOSFET driving LED string 4. |
| 3 | S6 | Source sense input 6 Source sense input for external MOSFET 6. Connect S6 to the source of the external MOSFET, and to the current sense resistor for LED string 6. The full-scale LED current is reached when 500mV is across the current sense resistor. |
| 4 | G6 | Gate output 6 Gate drive output for external MOSFET 6. Connect G6 to the gate of the external MOSFET driving LED string 6. |
| 5 | D6 | Drain sense input 6 Drain sense input for external MOSFET 6. Connect D6 through a 10MΩ resistor to the drain of the external MOSFET driving LED string 6. |
| 6 | NC | No connection Make no connection to NC. |
| 7 | SDA | I²C serial data I/O SDA is the data I/O for the I ² C serial interface. |
| 8 | SCL | I²C serial clock input SCL is the clock input for the I ² C serial interface. |
| 9 | GND | Ground Connect GND to system ground and to EP with short, wide traces. |
| 10 | FLTB | Fault indication output (active low) Open drain output FLTB sinks current to GND whenever a fault is detected and verified. FLTB remains low until the fault registers are read, and reasserts if the fault persists. |
| 11 | ADDR | Slave ID selection inputs Connect ADDR to a resistor to GND to set the device address for the serial interface. |
| 12 | FBO2 | Efficiency Optimizer output 2 Connect FBO2 to the second power supply's feedback node. If unused, leave FBO2 unconnected. |
| 13 | FBI1 | Efficiency Optimizer input 1 Connect FBI1 to FBO1 of the next device, when chaining the Efficiency Optimizers Connect FBI1 to GND if unused. |
| 14 | FBO1 | Efficiency Optimizer output 1 Connect FBO1 to the first power supply's feedback node. If unused, leave FBO1 unconnected. |
| 15 | S9 | Source sense input 9 Source sense input for external MOSFET 9. Connect S9 to the source of the external MOSFET, and to the current sense resistor for LED string 9. The full-scale LED current is reached when 500mV is across the current sense resistor. |
| 16 | G9 | Gate output 9 Gate drive output for external MOSFET 9. Connect G9 to the gate of the external MOSFET driving LED string 9. |
| 17 | D9 | Drain sense input 9 Drain sense input for external MOSFET 9. Connect D9 through a 10MΩ resistor to the drain of the external MOSFET driving LED string 9. |
| 18 | S11 | Source sense input 11 Source sense input for external MOSFET 11. Connect S11 to the source of the external MOSFET, and to the current sense resistor for LED string 11. The full-scale LED current is reached when 500mV is across the current sense resistor. |
| 19 | G11 | Gate output 11 Gate drive output for external MOSFET 11. Connect G11 to the gate of the external MOSFET driving LED string 11. |
| 20 | D11 | Drain sense input 11 Drain sense input for external MOSFET 11. Connect D11 through a 10MΩ resistor to the drain of the external MOSFET driving LED string 11. |

Atmel LED Driver-MSL3085

8-string White and RGB LED Driver with Adaptive Power Control, EEPROM, and I²C/SMBus Serial Interface

| PIN | PIN NAME | PIN DESCRIPTION |
|-----|----------|--|
| 21 | S12 | Source sense input 12 Source sense input for external MOSFET 12. Connect S12 to the source of the external MOSFET, and to the current sense resistor for LED string 12. The full-scale LED current is reached when 500mV is across the current sense resistor. |
| 22 | G12 | Gate output 12 Gate drive output for external MOSFET 12. Connect G12 to the gate of the external MOSFET driving LED string 12. |
| 23 | D12 | Drain sense input 12 Drain sense input for external MOSFET 12. Connect D12 through a 10MΩ resistor to the drain of the external MOSFET driving LED string 12. |
| 24 | S14 | Source sense input 14 Source sense input for external MOSFET 14. Connect S14 to the source of the external MOSFET, and to the current sense resistor for LED string 14. The full-scale LED current is reached when 500mV is across the current sense resistor. |
| 25 | G14 | Gate output 14 Gate drive output for external MOSFET 14. Connect G14 to the gate of the external MOSFET driving LED string 14. |
| 26 | D14 | Drain Sense Input 14 Drain sense input for external MOSFET 14. Connect D14 through a 10MΩ resistor to the drain of the external MOSFET driving LED string 14. |
| 27 | VCC | 5V internal LDO regulator output VCC powers the FBO outputs. Bypass VCC to GND with a 4.7μF ceramic capacitor placed close to VCC. |
| 28 | PHI | Phase synchronization input Drive PHI with an external signal of typically 100Hz to 480Hz to synchronize the MSL3085 LED PWM timing. |
| 29 | GSC | Gate shift clock input Drive GSC with the gate shift clock of the video signal. |
| 30 | PWM | PWM input PWM allows external control of the brightness of all LED strings. Drive PWM with a pulse-width-modulated signal with a duty cycle of 0% to 100% and a frequency up to 5kHz. When not configured as an input, PWM is high impedance. |
| 31 | EN | Enable input (active high) Drive EN high to turn on the MSL3085, and drive EN low to turn off the MSL3085. For automatic start-up, connect EN to VIN. When EN is low, the entire device, including the serial interface, is turned off. Driving EN high initiates a boot load of the EEPROM data into the control registers, simulating a cold start-up. |
| 32 | VIN | Supply voltage input Connect a 12V ±10% supply to VIN. Bypass VIN to GND with a 10μF ceramic capacitor placed close to VIN. |
| 33 | VDD | 2.5V internal LDO regulator output VDD powers internal logic. Bypass VDD to GND with a 4.7μF ceramic capacitor placed close to VDD. |
| 34 | S0 | LED string 0 external MOSFET source input Source sense input for external MOSFET 0. Connect S0 to the source of the external MOSFET, and to the current sense resistor for LED string 0. The full-scale LED current is reached when 500mV is across the current sense resistor. |
| 35 | G0 | Gate output 0 Gate drive output for external MOSFET 0. Connect G0 to the gate of the external MOSFET driving LED string 0. |
| 36 | D0 | Drain sense input 0 Drain sense input for external MOSFET 0. Connect D0 through a 10MΩ resistor to the drain of the external MOSFET driving LED string 0. |
| 37 | S2 | LED string 2 external MOSFET source input Source sense input for external MOSFET 2. Connect S2 to the source of the external MOSFET, and to the current sense resistor for LED string 2. The full-scale LED current is reached when 500mV is across the current sense resistor. |
| 38 | G2 | Gate output 2 Gate drive output for external MOSFET 2. Connect G2 to the gate of the external MOSFET driving LED string 2. |
| 39 | D2 | Drain sense input 2 Drain sense input for external MOSFET 2. Connect D2 through a 10MΩ resistor to the drain of the external MOSFET driving LED string 2. |
| 40 | S4 | LED string 4 external MOSFET source input Source sense input for external MOSFET 4. Connect S4 to the source of the external MOSFET, and to the current sense resistor for LED string 4. The full-scale LED current is reached when 500mV is across the current sense resistor. |
| EP | EP | Exposed pad, power ground Connect EP to system ground and to GND using short, wide traces. EP provides thermal relief for the die. |



Absolute Maximum Ratings

Voltage (With Respect to GND)

| | |
|--|-----------------------|
| VIN, EN, D0 thru D14, G0 thru G14..... | -0.3V to +18V |
| VCC..... | -0.3V to +6V |
| VDD, ADDR, S0 thru S14..... | -0.3V to +2.75V |
| FBO1, FBO2, FLTB..... | -0.3V to +5.5V |
| PHI, GSC, PWM..... | -0.3V to (VCC + 0.3V) |
| SDA, SCL..... | -0.3V to +5.5V |

Current (Into Pin)

| | |
|---------------------|----------------------------|
| VIN..... | 50mA |
| FBO1, FBO2..... | +0 μ A to -800 μ A |
| G0 thru G14..... | \pm 100mA |
| All other pins..... | 20mA |

Continuous Power Dissipation

| | |
|---|--------|
| 40-Pin 6mm x 6mm QFN (derate 38mW/ $^{\circ}$ C above $T_A = +70^{\circ}$ C)..... | 2100mW |
|---|--------|

Ambient Operating Temperature range $T_A = T_{MIN}$ to T_{MAX} -40 $^{\circ}$ C to +105 $^{\circ}$ C

Junction Temperature..... +125 $^{\circ}$ C

Storage Temperature range..... -65 $^{\circ}$ C to +125 $^{\circ}$ C

Lead Soldering Temperature, 10s..... +300 $^{\circ}$ C

Electrical Characteristics

Typical application circuit, $V_{VIN} = 12V$, $T_A = T_{MIN}$ to T_{MAX} , unless otherwise noted. Typical values are at $V_{VIN} = 12V$, $T_A = +25^{\circ}$ C

| PARAMETER | SYMBOL | CONDITIONS AND NOTES | MIN | TYP | MAX | UNIT |
|--------------------------------------|-------------|---|------|-----|------|---------|
| DC ELECTRICAL CHARACTERISTICS | | | | | | |
| VIN operating supply voltage | VIN | | 10.8 | 12 | 13.2 | V |
| VIN operating supply current | I_{VIN} | Normal operation, all LED strings driven | | 25 | 32.5 | mA |
| VIN shutdown supply current | I_{SLEEP} | SLEEP = 1, SDA, SCL, ADDR, PWM, PHI and GSC at GND or VDD | | 500 | | μ A |
| VCC regulation voltage | VCC | $I_{VCC} = -1.0mA$ | 4.5 | 5.0 | 5.5 | V |
| VDD regulation voltage | VDD | $I_{VDD} = -1.0mA$ | 2.4 | 2.5 | 2.6 | V |
| EN input high voltage | | | 1.4 | | | V |

Atmel LED Driver-MSL3085

8-string White and RGB LED Driver with Adaptive Power Control, EEPROM, and I²C/SMBus Serial Interface

| PARAMETER | SYMBOL | CONDITIONS AND NOTES | MIN | TYP | MAX | UNIT |
|--|-----------------|----------------------------------|-----------|-----|-----------|------|
| EN input low voltage | | | | | 0.9 | V |
| PWM, PHI, GSC input high voltage | V _{IH} | | 0.7 x VDD | | | V |
| PWM, PHI, GSC input low voltage | V _{IL} | | | | 0.3 x VDD | V |
| PHI, GSC output high voltage | V _{OH} | I _{SOURCE} = 5mA | VDD - 0.4 | | | |
| PHI, GSC, FLTB output low voltage | V _{OL} | I _{SINK} = 6mA | | | 0.4 | V |
| FBO feedback output current | | Compliance voltage 3.5V, minimum | 0 | | 360 | μA |
| FBO feedback output current step size | | | | 1.2 | | μA |
| D0 thru D7 short circuit fault detection threshold | | | | 8 | | V |
| G0 thru G7 open circuit fault detection threshold | | | | 8 | | V |
| G0 thru G14 gate drive charge | | (Note 2) | | | 10 | μC |
| S0 thru S7 regulation voltage | | | 492 | 500 | 508 | mV |
| S0 thru S7 voltage matching | | ISTR = 0x7F | -1.5 | | 1.5 | % |
| Thermal shutdown temperature | | | | TBD | | °C |

| PARAMETER | SYMBOL | CONDITIONS AND NOTES | MIN | TYP | MAX | UNIT |
|------------------------------------|--------|-------------------------|-----------|-----|-----------|------|
| I²C LOGIC LEVELS | | | | | | |
| SDA, SCL input high voltage | | | 0.7 x VDD | | | V |
| SDA, SCL input low voltage | | | | | 0.3 x VDD | V |
| SDA output low voltage | | I _{SINK} = 6mA | | | 0.4 | V |

| PARAMETER | SYMBOL | CONDITIONS AND NOTES | MIN | TYP | MAX | UNIT |
|--------------------------------------|------------------|---|------|-----|------|------------|
| AC ELECTRICAL CHARACTERISTICS | | | | | | |
| OSC frequency | f _{OSC} | f _{OSC} = 20MHz, T _A = 25°C | 19.4 | 20 | 20.6 | MHz |
| PHI frequency | f _{PHI} | | 0.04 | | 10 | kHz |
| GSC frequency | f _{GSC} | | 0 | | 10 | MHz |
| PWM frequency | f _{PWM} | | | | 5 | kHz |
| PWM duty cycle | | | 0 | | 100 | % |
| PHI lock | | | | 4 | | PHI cycles |



| PARAMETER | SYMBOL | CONDITIONS AND NOTES | MIN | TYP | MAX | UNIT |
|--|----------------------|---|----------------------------|-----|------|------|
| I²C TIMING CHARACTERISTICS | | | | | | |
| SCL clock frequency | 1/t _{SCL} | Bus timeout disabled (Note 3) | 0 | | 1 | MHz |
| Bus time-out period | t _{timeout} | f _{OSC} = 20MHz, T _A = 25°C | 29 | 30 | 31 | ms |
| | | f _{OSC} = 16MHz to 23MHz | 600,000 / f _{OSC} | | | s |
| STOP to START condition bus free time | t _{BUF} | | 0.5 | | | µs |
| Repeated START condition hold time | t _{HD:STA} | | 0.26 | | | µs |
| Repeated START condition set-up time | t _{SU:STA} | | 0.26 | | | µs |
| STOP condition set-up time | t _{SU:STOP} | | 0.26 | | | µs |
| SDA data hold time | t _{HD:DAT} | | 0 | | | ns |
| SDA data valid acknowledge time | t _{VD:ACK} | (Note 4) | 0.05 | | 0.45 | µs |
| SDA data valid time | t _{VD:DAT} | (Note 5) | 0.05 | | 0.45 | µs |
| SDA data set-up time | t _{SU:DAT} | | 100 | | | ns |
| SCL clock low period | t _{LOW} | | 0.5 | | | µs |
| SCL clock high period | t _{HIGH} | | 0.26 | | | µs |
| SDA, SCL fall time | t _f | (Note 6) (Note 7) | | | 120 | ns |
| SDA, SCL rise time | t _r | | | | 120 | ns |
| SDA, SCL input suppression filter period | t _{SP} | (Note 8) | | 50 | | ns |

Note 1. Subject to thermal dissipation characteristics of the device.

Note 2. Guaranteed by design, and is not production tested.

Note 3. Minimum SCL clock frequency is limited by the bus time-out feature, which resets the serial bus interface if either SDA or SCL is held low for t_{timeout}. Disable bus time-out via the fault enable register 0x03[6].

Note 4. t_{VD:ACK} = SCL low to SDA (out) low acknowledge time.

Note 5. t_{VD:DAT} = minimum SDA output data valid time following SCL low transition.

Note 6. A master device must internally provide an SDA hold time of at least 300ns to ensure an SCL low state.

Note 7. The maximum SDA and SCL rise times are 300ns. The maximum SDA fall time is 250ns. This allows series protection resistors to be connected between SDA and SCL inputs and the SDA/SCL bus lines without exceeding the maximum allowable rise time.

Note 8. Input filters on SDA, SCL, and ADDR suppress noise less than 50ns.



Detailed Description

The MSL3085 is a highly integrated, flexible, multi-string LED driver that uses external MOSFETs to allow high LED string currents, and includes power supply control to maximize efficiency. The driver optionally connects to a video subsystem to offer a simple architecture for use in LCD TV backlight applications. Up to eight devices easily connect together to drive a large number of LED strings in a system. The drivers provide multiple methods of controlling LED brightness through both peak current control and pulse width control of the string drive signals. Peak current control offers excellent color consistency, while pulse width control allows brightness management. An on-chip EEPROM holds all the default control register values. At power-up, the data in the EEPROM is automatically copied directly to the control registers, setting up the device for operation. The factory programmed EEPROM values are changeable through the serial interface if a different power-up condition is desired.

The device interfaces to an MCU via the I²C interface. The robust, 1MHz I²C interface supports up to eight devices on the bus. While typically the LED drive PWM signal is internally generated, the device also accepts an external direct PWM drive signal applied to the PWM input that sets the PWM duty cycle and the frequency of the LED drive signals. The MSL3085 also allows phase spreading of the LED drive signals, which helps reduce both the transient load on the LED power supplies and the power supply input capacitor size requirements.

The MSL3085 is an eight string version of the MSL2161, squeezed into a smaller package, with two efficiency optimizer (EO) outputs and one EO input. (The MSL2161 offers 16 string drives, three EO outputs, and three EO inputs.) This offers the advantage of small size, but to ensure register compatibility with the MSL2161, pin names of the FET drive outputs are not sequential. The FET drive outputs are named 0, 2, 4, 6, 9, 11, 12, and 14 (not 0 through 7). All control registers also follow this naming convention. Additionally, this has a small impact on the automatic phase-shift feature, whose sequential phase shifts for outputs 9 and 12 are spaced at 1/16th the PWM frame, while the others are spaced at 1/8th the PWM frame.

The PWM frequency of the drivers is easily synchronized to an external video signal applied to PHI,

synchronized to the internal oscillator for standalone applications, or set directly by a signal at the PWM input. Typically, the VSYNC signal from the video system is used as the PHI input. A frequency multiplier (1x to 32x) processes this signal for use by the PWM engine. The on time of each string is individually programmed via the device registers, providing a peak resolution of 12 bits when using the on-chip PWM generator. The actual resolution of the PWM frequency depends on the ratio of the GSC frequency (typically provided by a system's HSYNC signal, but can be internally generated) to the PHI frequency because the on time of a string is programmed as a 12-bit count of the number of GSC clock cycles. This count can be further scaled by an 8-bit global intensity register, when enabled. The GSC clock is also used to precisely set each string's phase delay so that it is synchronized to its physical position relative to the video frame.

The efficiency optimizers control a wide range of different external DC-DC and AC/DC converter architectures. Multiple drivers in a system communicate in real time among themselves to select an optimized operating voltage for the LEDs. This allows design of the power supply for the worst case forward voltage (V_f) of the LEDs without concern about excessive power dissipation issues. During the start-up sequence, the MSL3085 automatically reduces the power supply voltage to the minimum voltage required to keep the LEDs in current regulation. The devices are configured to periodically perform this optimization to compensate for changes in LED forward voltage, and to assure continued optimum power savings.

Internal Regulators and Enable Input

The MSL3085 includes two internal linear regulators that provide VCC (5V) and VDD (2.5V) for internal circuitry. VIN (12V nominal) supplies the VCC and VDD regulators. Bypass VIN to GND with a 10 μ F capacitor close to the device. Bypass VCC to GND with a 4.7 μ F capacitor close to the device. Bypass VDD to GND with a 4.7 μ F capacitor close to the device.

Atmel LED Driver-MSL3085

8-string White and RGB LED Driver with Adaptive Power Control, EEPROM, and I²C/SMBus Serial Interface

The MSL3085 enable input, EN, enables the device. Drive EN low to enter low power operation, which lowers quiescent current draw to less than 20µA. With EN low, the serial interface is ignored, the efficiency optimizer is disabled, and all strings are turned off. Drive EN high to turn on the device. When EN is driven high, the contents of the EEPROM are boot loaded into the control registers, simulating a cold start-up, and all bits in the fault registers are cleared to 0.

Setting the Maximum LED String Current With a Source Resistor

The maximum string current, I_{LED} , for each string is set by a resistor, R_S , connected to ground from the source terminal of the external string drive MOSFET. The feedback threshold is 500mV. Determine the resistor value using:

$$R_S = \frac{0.5}{I_{LED}}, \text{ where } I_{LED} \text{ is in amperes and } R_S \text{ is in ohms.}$$

For example, a full-scale LED current of 100mA returns $R_S = 5\Omega$. The current for all LED strings is reduced from the full-scale value with 8-bit resolution using ISTR, the string current control register 0x31.

Connecting the Efficiency Optimizer to an LED String Power Supply and Selecting Resistors

The MSL3085 is designed to control an external LED string power supply that uses a voltage divider (R_{TOP} and R_{BOTTOM} in Figure 4) to set output voltage, and whose regulation feedback voltage is not more than 3.5V. The efficiency optimizer improves power efficiency by injecting a current of between 0 and 255µA into the voltage divider of the external power supply, dynamically adjusting the power supply's output to the minimum voltage required by the LED strings. To select the resistors, first determine $V_{OUT(MIN)}$ and $V_{OUT(MAX)}$, the minimum and maximum string supply voltage limits, using:

$$V_{OUT(MIN)} = (V_{f(MIN)} * [\#ofLEDs]) + 0.5 ,$$

and

$$V_{OUT(MAX)} = (V_{f(MAX)} * [\#ofLEDs]) + 0.5 ,$$

where $V_{f(MIN)}$ and $V_{f(MAX)}$ are the LED minimum and maximum forward voltage drops at the peak current set by R_S . For example, if the LED data are $V_{f(MIN)} = 3.5V$ and $V_{f(MAX)} = 3.8V$, and ten LEDs are used in a string, then the total minimum and maximum voltage drops across a string are 35V and 38V, respectively. Adding an allowance of 0.5V for the string drive MOSFET headroom brings $V_{OUT(MIN)}$ to 35.5V and $V_{OUT(MAX)}$ to 38.5V. Then, determine R_{TOP} using:

$$R_{TOP} = \frac{V_{OUT(MAX)} - V_{OUT(MIN)}}{I_{FBOh(MAX)}}$$

where $I_{FBOh(MAX)}$ is the 255µA maximum output current of the efficiency optimizer outputs FBOh. Finally, determine R_{BOTTOM} using:

$$R_{BOTTOM} = R_{TOP} * \frac{V_{FB}}{V_{OUT(MAX)} - V_{FB}}$$

where V_{FB} is the regulation feedback voltage of the power supply. Place a diode (1N4148 or similar) between FBOh and the supply's feedback node to protect the MSL3085 against current flow into FBOh. Assign all strings powered by a common supply to the proper FBO output using string set registers 0x40 - 0x5D.

Once configured, determine the change in power supply output voltage in response to a change in FBOh output current using:

$$\Delta V_{OUT} = \Delta I_{FBO} * R_{TOP}$$

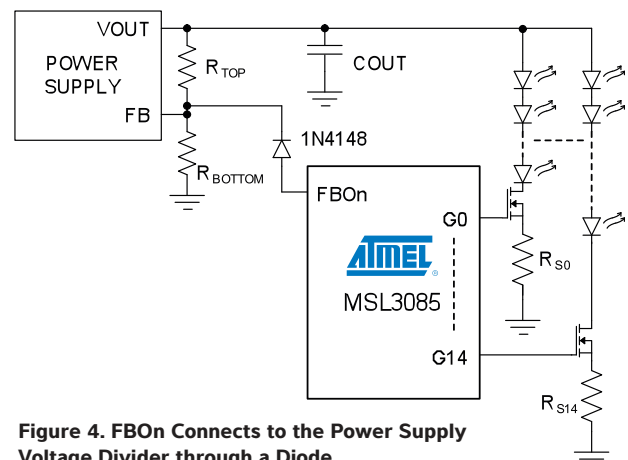

Figure 4. FBOh Connects to the Power Supply Voltage Divider through a Diode.



Using Multiple Atmel LED Driver-MSL3085s to Control a Common Power Supply

Cascade multiple MSL3085 devices into a chain configuration (Figure 5), with the FBI1 of one device connected to the FBO1 of the next. Connect the first FBO1 to the power supply feedback resistor node through a diode, and the unused FBI1 input to ground as close to the MSL3085 as possible. Assume that all strings powered by the common supply are assigned to FBO1 using string set registers (STRnSET) 0x20 - 0x3D (FBO1 is the power-up default setting for all strings). The chained devices work together to ensure that the system operates at optimum efficiency. Note that the accuracy of the feedback chain can degrade through each link of the FBI1/FBO1 chain by as much as 2%. Determine the potential worst case maximum FBO1 current, $I_{FBO1(MAX/MIN)}$, using:

$$I_{FBO1(MAX/MIN)} = 255\mu A * (0.98)^{N-1},$$

where N is the number of MSL3085s connected in series. Use this result in the above R_{TOP} resistor equation for the term $I_{FBO1(MAX)}$ instead of using 255µA.

Take care in laying out the traces for the efficiency optimizer connections. Minimize the FBI1/FBO1 trace lengths as much as possible. Do not route the signals close to traces with large variations in voltage or current because noise may couple into FBI1. If these traces must be routed near noisy signals, shield them from noise by using ground planes or guard traces.

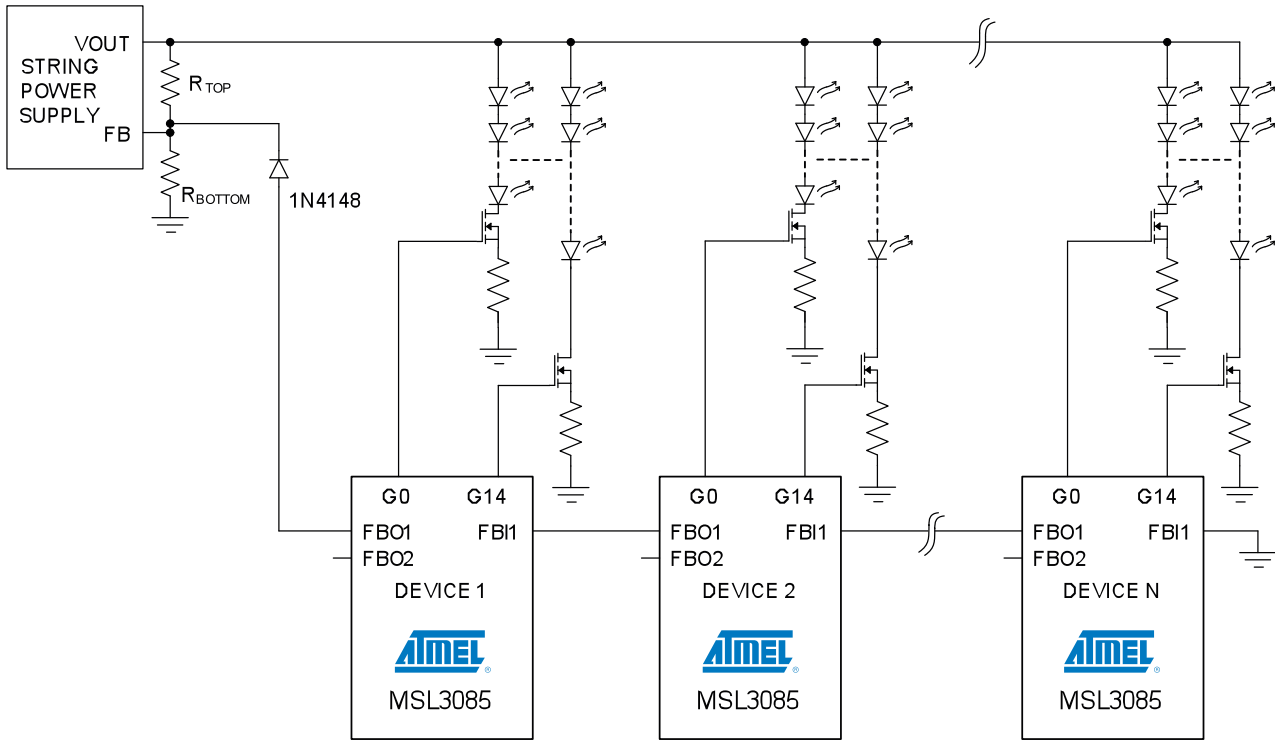

Figure 5. Example of Cascading Multiple Devices to Optimize a Common String Power Supply.

Atmel LED Driver-MSL3085

8-string White and RGB LED Driver with Adaptive Power Control, EEPROM, and I²C/SMBus Serial Interface

Direct PWM Control of the LED Strings

An external PWM signal applied to the PWM input allows direct PWM control over the strings when PWMEN and PWMDIRECT (bits D0 and D1 in PWM control register 0x2D) are set to 1. This configuration bypasses PHI and GSC, but allows LED string phase delay via the phase delay enable bit, PHADLYEN (bit D0 of register 0x2E). With phase delay enabled, a progressive delay based on the period of the PWM frame is calculated and applied successively to each string drive signal. The delay is typically 1/8th the PWM frame, but outputs 9 and 12 have sequential delays of 3/16th and 1/16th of the PWM frame, respectively.

The PWM input can also be configured as a gate for the output of the PWM engine using PWM global enable (bit D2 of the PWM control register 0x2D).

Register Map and the EEPROM

Register Map Summary

Control the MSL3085 using the registers in the range 0x00 - 0xBD (Table 2). Two additional registers, 0xC0 and 0xC1, allow access to, and programming of, the EEPROM. The power-up default values for all control registers are stored within the on-chip EEPROM, and any of these EEPROM values may be changed through the serial interface

Table 2. Atmel LED Driver-MSL3085 Register Map

| ADDRESS AND REGISTER NAME | | FUNCTION | REGISTER DATA | | | | | | | |
|---------------------------|------------|-----------------------------------|---------------|---------|----------------------|-----------|-------------|---------------|---------------|------------|
| | | | D7 | D6 | D5 | D4 | D3 | D2 | D1 | D0 |
| 0x00 | STRINGEN0 | LED string enables | - | STR6EN | - | STR4EN | - | STR2EN | - | STROEN |
| 0x01 | STRINGEN1 | | - | STR14EN | - | STR12EN | STR11EN | - | STR9EN | - |
| 0x02 | CONFIG | Configuration | SLEEP | - | - | - | FLDBKEN | STRSCDLY[2:0] | | |
| 0x03 | FLTEN | Fault enable | - | - | I ² CTOEN | PHIMAXFEN | GSCMAXFEN | STRSCFEN | STROCFEN | FBOOCFEN |
| 0x04 | STRFLTEN0 | String fault enable | - | FEN6 | - | FEN4 | - | FEN2 | - | FEN0 |
| 0x05 | STRFLTEN1 | | - | FEN14 | - | FEN12 | FEN11 | - | FEN9 | - |
| 0x06 | FLTSTATUS* | Fault status | FLTBDRV | - | - | PHIMAXFLT | GSCMAXFLT | STRSCFLT | STROCFLT | FBOOCFLT |
| 0x07 | OCSTAT0* | String open circuit fault status | - | OC6 | - | OC4 | - | OC2 | - | OC0 |
| 0x08 | OCSTAT1* | | - | OC14 | - | OC12 | OC11 | - | OC9 | - |
| 0x09 | SCSTAT0* | String short circuit fault status | - | SC6 | - | SC4 | - | SC2 | - | SC0 |
| 0x0A | SCSTAT1* | | - | SC14 | - | SC12 | SC11 | - | SC9 | - |
| 0x0B - 0x0E | | UNUSED | | | | | | | | |
| 0x0F | OSCFREQ | Oscillator frequency | - | - | - | - | - | OSCFREQ[2:0] | | |
| 0x10 | FBOCTRL0 | Efficiency Optimizer control | HDRMSTEP[1:0] | | RECALDLY[1:0] | | SETTLE[1:0] | | IERRCONF[1:0] | |
| 0x11 | FBOCTRL1 | | INCRSTEP[1:0] | | DECRSTEP[1:0] | | INITPWM | ACAL100 | ACALEN | ICHKDIS |
| 0x12 | FBOCTRL2 | | - | - | - | - | - | FBO2OCEN | FBO1OCEN | FBOEN |
| 0x13 | FBODAC1* | Efficiency Optimizer DAC readback | FBODAC1[7:0] | | | | | | | |
| 0x14 | FBODAC2* | | FBODAC2[7:0] | | | | | | | |
| 0x15 | | UNUSED | | | | | | | | |
| 0x16 | FBOSTAT* | Efficiency Optimizer status | - | FBO2OC | FBO1OC | - | FBO2ACT | FBO1ACT | FBOCAL | FBOINITCAL |



Table 2. Atmel LED Driver-MSL3085 Register Map

| ADDRESS AND REGISTER NAME | | FUNCTION | REGISTER DATA | | | | | | | |
|---------------------------|------------|--|--------------------|--------|------------|-----------------|-----------|--------------|---------------|----------|
| | | | D7 | D6 | D5 | D4 | D3 | D2 | D1 | D0 |
| 0x17 | - 0x1F | | UNUSED | | | | | | | |
| 0x20 | GSCCTRL | GSC processing control | GSCCHK-SEL | - | - | - | GSCMAXEN | GSCPOL | GSCPHI-SYNCEN | GSCINTEN |
| 0x21 | GSCCNTR | Internal clock counter for GSC | GSCCNTR[7:0] | | | | | | | |
| 0x22 | | | GSCCNTR[15:8] | | | | | | | |
| 0x23 | GSCMUL | GSC multiplier | - | - | - | GSCMUL[4:0] | | | | |
| 0x24 | GSCDIV | GSC divider | GSCDIV[7:0] | | | | | | | |
| 0x25 | GSCMAX | Max oscillator cycles between GSC pulses | GSCMAX[7:0] | | | | | | | |
| 0x26 | | | GSCMAX[15:8] | | | | | | | |
| 0x27 | PHICTRL | PHI processing control | PHICCHK-SEL | - | - | - | - | PHIMAXEN | PHIPOL | PHIINTEN |
| 0x28 | PHICNTR | Internal clock counter for PHI | PHICNTR[7:0] | | | | | | | |
| 0x29 | | | PHICNTR[15:8] | | | | | | | |
| 0x2A | PHIMUL | PHI multiplier | - | - | - | PHIMUL[4:0] | | | | |
| 0x2B | PHIMAX | Max GSC cycles between PHI pulses | PHIMAX[7:0] | | | | | | | |
| 0x2C | | | PHIMAX[15:8] | | | | | | | |
| 0x2D | PWMCTRL0 | PWM control | GINT+1EN | GINTEN | ALTEN | OVRFLOZEN | OVRFLOEN | PWM GLBLEN | PWMDIRECT | PWMEN |
| 0x2E | PWMCTRL1 | | - | - | - | - | EXTALTEN | PHOVR FLOZEN | PHOVR FLOEN | PHADLYEN |
| 0x2F | GINT | Global PWM scaling | GINT[7:0] | | | | | | | |
| 0x30 | ALTGINT | Alternate global PWM scaling | ALTGINT[7:0] | | | | | | | |
| 0x31 | ISTR | 8-bit global string current scaling | ISTR[7:0] | | | | | | | |
| 0x32 | PWMSTATUS* | PWM and counter status | PHIMAXERRCNT[2:0] | | PHIMAX1FLT | PHISIGFLT | GSCSIGFLT | PHICNTRFLT | GINT-MULERR | |
| 0x33 | PHIPCNTR* | PHI pulse counter and status | PHICNTR-MAX | - | - | PHIMULCNTR[0:4] | | | | |
| 0x34 | GSCPCNTR* | GSC pulse counter | GSCPULSECNTR[7:0] | | | | | | | |
| 0x35 | | | GSCPULSECNTR[12:8] | | | | | | | |
| 0x36 - 0x3F | | | UNUSED | | | | | | | |

Atmel LED Driver-MSL3085

8-string White and RGB LED Driver with Adaptive Power Control, EEPROM, and I²C/SMBus Serial Interface

| ADDRESS AND REGISTER NAME | | FUNCTION | REGISTER DATA | | | | | | |
|---------------------------|-------------|---|-----------------|-------------|-------|-------------|----------------|-------------|----|
| | | | D7 | D6 | D5 | D4 | D3 | D2 | D1 |
| 0x40 | STR0SET | Phase delay and EO assignment for string 0 | PHDLY0[7:0] | | | | | | |
| 0x41 | | | FBOSET0[1:0] | - | - | PHDLY[11:8] | | | |
| ↓ | ↓ | ↓ | | | | | | | |
| 0x5C | STR14SET | Phase delay and EO assignment for string 14 | PHDLY14[7:0] | | | | | | |
| 0x5D | | | FBOSET14[1:0] | - | - | PHDLY[11:8] | | | |
| 0x5E and 0x5F | | | UNUSED | | | | | | |
| 0x60 | PWM0 | PWM setting for string 0 | PWM0[7:0] | | | | | | |
| 0x61 | | | - | - | - | - | PWM0[11:8] | | |
| ↓ | ↓ | ↓ | | | | | | | |
| 0x7C | PWM14 | PWM setting for string 14 | PWM14[7:0] | | | | | | |
| 0x7D | | | - | - | - | - | PWM14[11:8] | | |
| 0x7E and 0x7F | | | UNUSED | | | | | | |
| 0x80 | ALTSTR0SET | Alternate phase delay for string 0 | ALTPHDLY0[7:0] | | | | | | |
| 0x81 | | | - | - | - | - | ALTPHDLY[11:8] | | |
| ↓ | ↓ | | | | | | | | |
| 0x9C | ALTSTR14SET | Alternate phase delay for string 14 | ALTPHDLY14[7:0] | | | | | | |
| 0x9D | | | - | - | - | - | ALTPHDLY[11:8] | | |
| 0x9E and 0x9F | | | UNUSED | | | | | | |
| 0xA0 | ALTPWM0 | Alternate PWM setting for string 0 | ALTPWM0[7:0] | | | | | | |
| 0xA1 | | | - | - | - | - | ALTPWM0[11:8] | | |
| ↓ | ↓ | | | | | | | | |
| 0xBC | ALTPWM14 | Alternate PWM setting for string 14 | ALTPWM14[7:0] | | | | | | |
| 0xBD | | | - | - | - | - | ALTPWM14[11:8] | | |
| 0xBE and 0xBF | | | UNUSED | | | | | | |
| 0xC0 | E2ADDR | EEPROM read/write access | - | E2ADDR[6:0] | | | | | |
| 0xC1 | E2CTRLSTA | | E2BUSY | BLDACT | E2ERR | - | - | RWCTRL[2:0] | |



Register Power-up Defaults

Register power-up default values are shown in Table 3.

Table 3. Atmel LED Driver-MSL3085 Register Power-up Defaults

| REGISTER NAME AND ADDRESS | | POWER-UP CONDITION REGISTERS INITIALIZED FROM EEPROM | REGISTER DATA | | | | | | | | |
|---------------------------|-----------|---|---------------|----|----|----|----|----|----|----|-----|
| | | | D7 | D6 | D5 | D4 | D3 | D2 | D1 | D0 | HEX |
| 0x00 | STRINGEN0 | LED strings 0, 2, 4, 6, 9, 11, 12, and 14 enabled | 0 | 1 | 0 | 1 | 0 | 1 | 0 | 1 | 55 |
| 0x01 | STRINGEN1 | | 0 | 1 | 0 | 1 | 1 | 0 | 1 | 0 | 5A |
| 0x02 | CONFIG | String short circuit confirmation delay = 256 μ s String current fold-back enabled Device awake | 0 | 0 | 0 | 0 | 1 | 1 | 0 | 1 | 0D |
| 0x03 | FLTEN | FBO open circuit fault detect globally enabled String open circuit fault detect globally enabled LED short circuit fault detect globally enabled GSC max fault detect globally disabled PHI max fault detect globally disabled I ² C timeout enabled | 0 | 0 | 1 | 0 | 0 | 1 | 1 | 1 | 27 |
| 0x04 | STRFLTEN0 | Fault detection individually enabled For all strings (0, 2, 4, 6, 9, 11, 12, and 14) | 0 | 1 | 0 | 1 | 0 | 1 | 0 | 1 | 55 |
| 0x05 | STRFLTEN1 | | 0 | 1 | 0 | 1 | 1 | 0 | 1 | 0 | 5A |
| 0x0F | OSCFREQ | $f_{osc} = 20\text{MHz}$ | 0 | 0 | 0 | 0 | 0 | 1 | 0 | 0 | 04 |
| 0x10 | FBOCTRL0 | Current sink error confirmation delay = 2 μ s FBO power supply correction delay = 4ms Efficiency Optimizer auto-recalibration delay = 1s | 0 | 1 | 0 | 0 | 1 | 0 | 0 | 1 | 49 |
| 0x11 | FBOCTRL1 | Efficiency Optimizer headroom steps = 3 MOSFET current sink error detection enabled Efficiency Optimizer auto-recalibration enabled | 0 | 0 | 0 | 1 | 1 | 0 | 1 | 0 | 1A |
| 0x12 | FBOCTRL2 | PWM settings used during auto-recalibration PWM settings used during initial calibration Efficiency Optimizer correction step size = 1 LSB (1 μ A) Efficiency Optimizer initial calibration step size = 1 LSB (1 μ A) FBO outputs globally enabled FBO1 open circuit detection enabled FBO2 open circuit detection disabled | 0 | 0 | 0 | 0 | 0 | 0 | 1 | 1 | 03 |
| 0x20 | GSCCTRL | External signal at GSC is selected for input to the PWM engine GSC not internally synchronized to PHI PWM drive synchronized to falling edge of external GSC signal GSC maximum count fault detect is disabled although disabled, GSC max fault monitors f_{pGSC} | 0 | 0 | 0 | 0 | 0 | 0 | 0 | 0 | 00 |
| 0x21 | GSCCNTR | Although disabled, internal GSC | 0 | 1 | 0 | 1 | 0 | 0 | 0 | 0 | 50 |
| 0x22 | | Frequency $f_{GEN} = 20\text{MHz} / (80 + 1) = 246\text{kHz}$ | 0 | 0 | 0 | 0 | 0 | 0 | 0 | 0 | 00 |
| 0x23 | GSCMUL | GSC multiplexer output is multiplied by 4 (register setting + 1) | 0 | 0 | 0 | 0 | 0 | 0 | 1 | 1 | 03 |
| 0x24 | GSCDIV | GSC multiplier output is divided by 1 (register setting + 1) | 0 | 0 | 0 | 0 | 0 | 0 | 0 | 0 | 00 |
| 0x25 | GSCMAX | Although disabled, GSC max count is set to 174 clock cycles | 1 | 0 | 1 | 0 | 1 | 1 | 1 | 0 | AE |
| 0x26 | | | 0 | 0 | 0 | 0 | 0 | 0 | 0 | 0 | 00 |
| 0x27 | PHICTRL | External signal at PHI selected for input to PWM engine PWM engine is synchronized to the falling edge of PHI PHI maximum count fault detect is disabled Although disabled, PHI max count monitors f_{pPHI} | 0 | 0 | 0 | 0 | 0 | 0 | 0 | 0 | 00 |

Atmel LED Driver-MSL3085

8-string White and RGB LED Driver with Adaptive Power Control, EEPROM, and I²C/SMBus Serial Interface

| REGISTER NAME AND ADDRESS | | POWER-UP CONDITION REGISTERS INITIALIZED FROM EEPROM | REGISTER DATA | | | | | | | | |
|-------------------------------------|-------------|--|---------------|----|----|----|----|----|----|----|-----|
| | | | D7 | D6 | D5 | D4 | D3 | D2 | D1 | D0 | HEX |
| 0x28 | PHICNTR | Although disabled, internal PHI | 1 | 0 | 1 | 1 | 0 | 0 | 0 | 0 | B0 |
| 0x29 | | Frequency $f_{PGEN} = 20\text{MHz} / (8 * (10416 + 1)) = 240\text{Hz}$ | 0 | 0 | 1 | 0 | 1 | 0 | 0 | 0 | 28 |
| 0x2A | PHIMUL | PHI multiplier = 1 (register setting + 1) | 0 | 0 | 0 | 0 | 0 | 0 | 0 | 0 | 00 |
| 0x2B | PHIMAX | Although disabled, PHI maximum count = 4148 | 0 | 0 | 1 | 1 | 0 | 1 | 0 | 0 | 34 |
| 0x2C | | | 0 | 0 | 0 | 1 | 0 | 0 | 0 | 0 | 10 |
| 0x2D | PWMCTRL0 | PWM operation enabled Individual LED string drive pulse widths internally determined PWM input does not gate the output of the PWM engine String on times allowed to extend beyond end of PWM frame String on times allowed to extend into frame zero Alternate timing not used Global intensity (GINT) disabled Although disabled, (GINT + 1) is provided to the PWM engine String drive phasing enabled Delayed string turn on beginning after PWM frame allowed Delayed turn on occurring in frame zero allowed Alternate timing not selected by PWM input state | 1 | 0 | 0 | 1 | 1 | 0 | 0 | 1 | 99 |
| 0x2E | PWMCTRL1 | | 0 | 0 | 0 | 0 | 0 | 1 | 1 | 1 | 07 |
| 0x2F | GINT | Global intensity set to $(127 + 1) / 255 = 50.2\%$ | 0 | 1 | 1 | 1 | 1 | 1 | 1 | 1 | 7F |
| 0x30 | ALTGINT | Alternate global intensity set to $(95 + 1) / 255 = 37.6\%$ | 0 | 1 | 0 | 1 | 1 | 1 | 1 | 1 | 5F |
| 0x31 | ISTR | Strings current set at 50% of R_s setting | 0 | 1 | 1 | 1 | 1 | 1 | 1 | 1 | 7F |
| 0x40 | STR0SET | All strings phase delay = zero All strings assigned to FBO1 | 0 | 0 | 0 | 0 | 0 | 0 | 0 | 0 | 00 |
| 0x41 | | | 0 | 1 | 0 | 0 | 0 | 0 | 0 | 0 | 0 |
| | ↓ | | ↓ | | | | | | | | |
| 0x5C | STR14SET | | 0 | 0 | 0 | 0 | 0 | 0 | 0 | 0 | 00 |
| 0x5D | | | 0 | 1 | 0 | 0 | 0 | 0 | 0 | 0 | 0 |
| 0x60 | PWM0 | All strings have PWM value = 512 GSC cycles | 0 | 0 | 0 | 0 | 0 | 0 | 0 | 0 | 00 |
| 0x61 | | | 0 | 0 | 0 | 0 | 0 | 0 | 1 | 0 | 02 |
| | ↓ | | ↓ | | | | | | | | |
| 0x7C | PWM14 | | 0 | 0 | 0 | 0 | 0 | 0 | 0 | 0 | 00 |
| 0x7D | | | 0 | 0 | 0 | 0 | 0 | 0 | 1 | 0 | 02 |
| 0x80 | ALTSTR0SET | All strings alternate phase delay = zero | 0 | 0 | 0 | 0 | 0 | 0 | 0 | 0 | 00 |
| 0x81 | | | 0 | 0 | 0 | 0 | 0 | 0 | 0 | 0 | 00 |
| | ↓ | | ↓ | | | | | | | | |
| 0x9C | ALTSTR14SET | | 0 | 0 | 0 | 0 | 0 | 0 | 0 | 0 | 00 |
| 0x9D | | | 0 | 0 | 0 | 0 | 0 | 0 | 0 | 0 | 00 |
| 0xA0 | ALTPWM0 | All strings set with alternate PWM value = 512 GSC cycles | 0 | 0 | 0 | 0 | 0 | 0 | 0 | 0 | 00 |
| 0xA1 | | | 0 | 0 | 0 | 0 | 0 | 0 | 1 | 0 | 02 |
| | ↓ | | ↓ | | | | | | | | |
| 0xBC | ALTPWM14 | | 0 | 0 | 0 | 0 | 0 | 0 | 0 | 0 | 00 |
| 0xBD | | | 0 | 0 | 0 | 0 | 0 | 0 | 1 | 0 | 02 |
| REGISTERS WITH FIXED INITIAL VALUES | | | | | | | | | | | |
| 0xC0 | E2ADDR | EEPROM 7-bit address = 0x00 | 0 | 0 | 0 | 0 | 0 | 0 | 0 | 0 | 00 |
| 0xC1 | E2CTRLSTA | EEPROM read/write disabled | 0 | 0 | 0 | 0 | 0 | 0 | 0 | 0 | 00 |

**Atmel Corporation**

2325 Orchard Parkway
San Jose, CA 95131
USA

Tel: (+1)(408) 441-0311

Fax: (+1)(408) 487-2600

www.atmel.com

Atmel Asia Limited

Unit 01-5 & 16, 19F
BEA Tower, Millennium City 5
418 Kwun Tong Road
Kwun Tong, Kowloon
HONG KONG

Tel: (+852) 2245-6100

Fax: (+852) 2722-1369

Atmel Munich GmbH

Business Campus
Parking 4
D-85748 Garching b. Munich
GERMANY

Tel: (+49) 89-31970-0

Fax: (+49) 89-3194621

Atmel Japan

9F, Tonetsu Shinkawa Bldg.
1-24-8 Shinkawa
Chuo-ku, Tokyo 104-0033
JAPAN

Tel: (+81)(3) 3523-3551

Fax: (+81)(3) 3523-7581

© 2011 Atmel Corporation. All rights reserved. / Rev.: MEM-MSL3085DB1-E-US_06-11

Atmel®, logo and combinations thereof, and others are registered trademarks or trademarks of Atmel Corporation or its subsidiaries. Other terms and product names may be trademarks of others.

Disclaimer: The information in this document is provided in connection with Atmel products. No license, express or implied, by estoppel or otherwise, to any intellectual property right is granted by this document or in connection with the sale of Atmel products. EXCEPT AS SET FORTH IN THE ATMEL TERMS AND CONDITIONS OF SALES LOCATED ON THE ATMEL WEBSITE, ATMEL ASSUMES NO LIABILITY WHATSOEVER AND DISCLAIMS ANY EXPRESS, IMPLIED OR STATUTORY WARRANTY RELATING TO ITS PRODUCTS INCLUDING, BUT NOT LIMITED TO, THE IMPLIED WARRANTY OF MERCHANTABILITY, FITNESS FOR A PARTICULAR PURPOSE, OR NON-INFRINGEMENT. IN NO EVENT SHALL ATMEL BE LIABLE FOR ANY DIRECT, INDIRECT, CONSEQUENTIAL, PUNITIVE, SPECIAL OR INCIDENTAL DAMAGES (INCLUDING, WITHOUT LIMITATION, DAMAGES FOR LOSS AND PROFITS, BUSINESS INTERRUPTION, OR LOSS OF INFORMATION) ARISING OUT OF THE USE OR INABILITY TO USE THIS DOCUMENT, EVEN IF ATMEL HAS BEEN ADVISED OF THE POSSIBILITY OF SUCH DAMAGES. Atmel makes no representations or warranties with respect to the accuracy or completeness of the contents of this document and reserves the right to make changes to specifications and products descriptions at any time without notice. Atmel does not make any commitment to update the information contained herein. Unless specifically provided otherwise, Atmel products are not suitable for, and shall not be used in, automotive applications. Atmel products are not intended, authorized, or warranted for use as components in applications intended to support or sustain life.