

REV.	DESCRIPTION	DATE	APPROVED
B	Engineering Release	02/27/15	J. C.
C	Revised Side View, See Page 4	03/20/15	J. C.
D	Corrected Typo in Recom. Soldering Pattern	09/12/16	J. C.

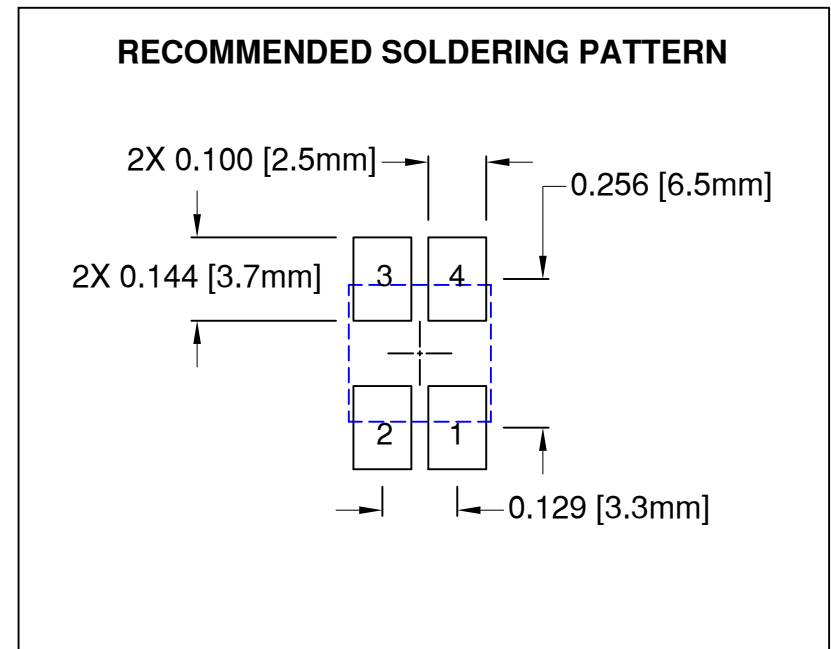
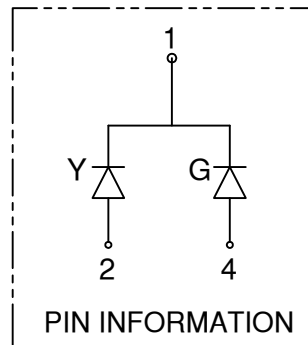
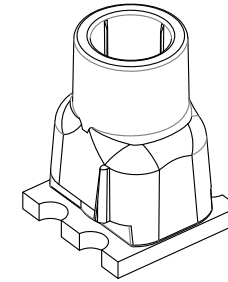
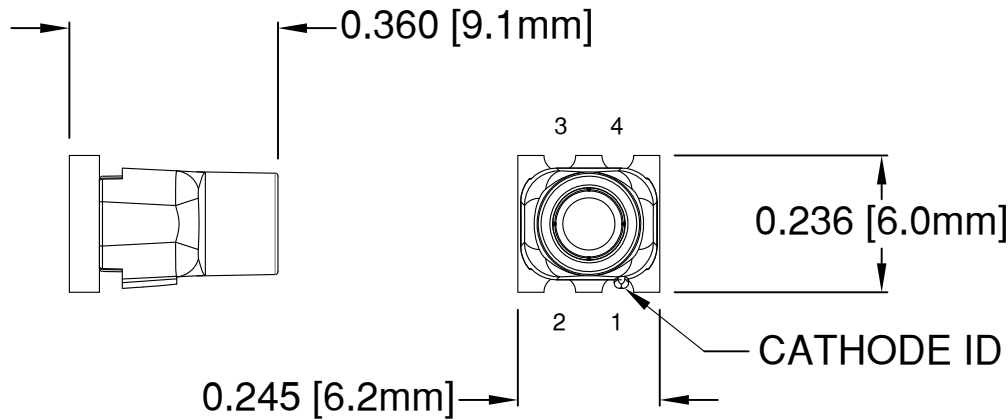

### ABSOLUTE MAXIMUM RATINGS at Ta=25°C

REVERSE VOLTAGE	5V
REVERSE CURRENT	100µA
OPERATING TEMPERATURE RANGE	-35°C - 85°C
STORAGE TEMPERATURE	-35°C - 85°C
MAX SOLDERING TEMPERATURE	260°C FOR 3 SECONDS

#### NOTES:

- DERATING OF FORWARD CURRENT PER SEGMENT, 0.30mA/°C at T ≥ 25°C
- ACCEPTS BIVAR FLEXIBLE LIGHT PIPE STYLE FLPS2031

STANDARD TOLERANCE (UNLESS OTHERWISE SPECIFIED)		 4 THOMAS, IRVINE, CA. 92618 TEL: (949) 951-8808 FAX: (949) 951-3974	
DECIMALS	ANGULAR		
.X ± .1	X° ± 1°	<b>TITLE:</b> SMT FLP VERTICAL ADAPTER BI-COLOR, YELLOW/GREEN	
.XX ± .02			
.XXX ± .010			
DESIGNED: <b>A. Wright</b>	DATE: <b>03/13/14</b>	<b>PART NO:</b> SMTV01-YXXGXX	REVISION: <b>D</b>
CHECKED: <b>B. Oliver</b>	DATE: <b>03/13/14</b>	<b>CAGE CODE :</b> 32559	<b>SHEET # 1 OF 4</b>
CAD GENERATED DOCUMENT. DO NOT MEASURE DRAWING.			

REV.	DESCRIPTION	DATE	APPROVED
	SEE SHEET #1		

Part Number	Chip				Absolute Maximum Ratings Per Segment			Electro-Optical Data @20mA, 25°C			
	Emitted Color	$\lambda_D$ [nm]			$P_d$ [mW]	$I_f$ [mA]	Peak $I_f$ [mA]	$V_f$ [V]			$I_v$ [mcd]
		MIN	TYP	MAX				MIN	TYP	MAX	TYP
SMTV01-Y11G15	YELLOW	585	590	595	60	25	100	1.8	2.1	2.6	110
	GREEN	510	515	520	60	25	100	2.8	3.3	3.8	149
SMTV01-Y14G33	YELLOW	585	590	595	60	25	100	1.8	2.1	2.6	143
	GREEN	510	515	520	60	25	100	2.8	3.3	3.8	325

Note: 10% Duty Cycle, Pulse Width  $\leq 0.1$ msec for Peak  $I_f$ .

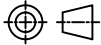
STANDARD TOLERANCE ( UNLESS OTHERWISE SPECIFIED )		 <b>BIVAR</b> <sup>®</sup> 4 THOMAS, IRVINE, CA. 92618 TEL: (949) 951-8808 FAX: (949) 951-3974	
DECIMALS	ANGULAR		
.X ± .1	X° ± 1°		<b>TITLE:</b> SMT FLP VERTICAL ADAPTER BI-COLOR, YELLOW/GREEN
.XX ± .02			
.XXX ± .010		<b>DESIGNED:</b> <b>A. Wright</b>	<b>DATE:</b> <b>03/13/14</b>
		<b>CHECKED:</b> <b>B. Oliver</b>	<b>DATE:</b> <b>03/13/14</b>
		<b>PART NO:</b> SMTV01-YXXGXX	<b>REVISION:</b> D
		<b>CAGE CODE :</b> 32559	<b>SHEET # 2 OF 4</b>
CAD GENERATED DOCUMENT. DO NOT MEASURE DRAWING.			

REV.	DESCRIPTION	DATE	APPROVED
	SEE SHEET #1		

## Recommended Reflow Soldering Profile

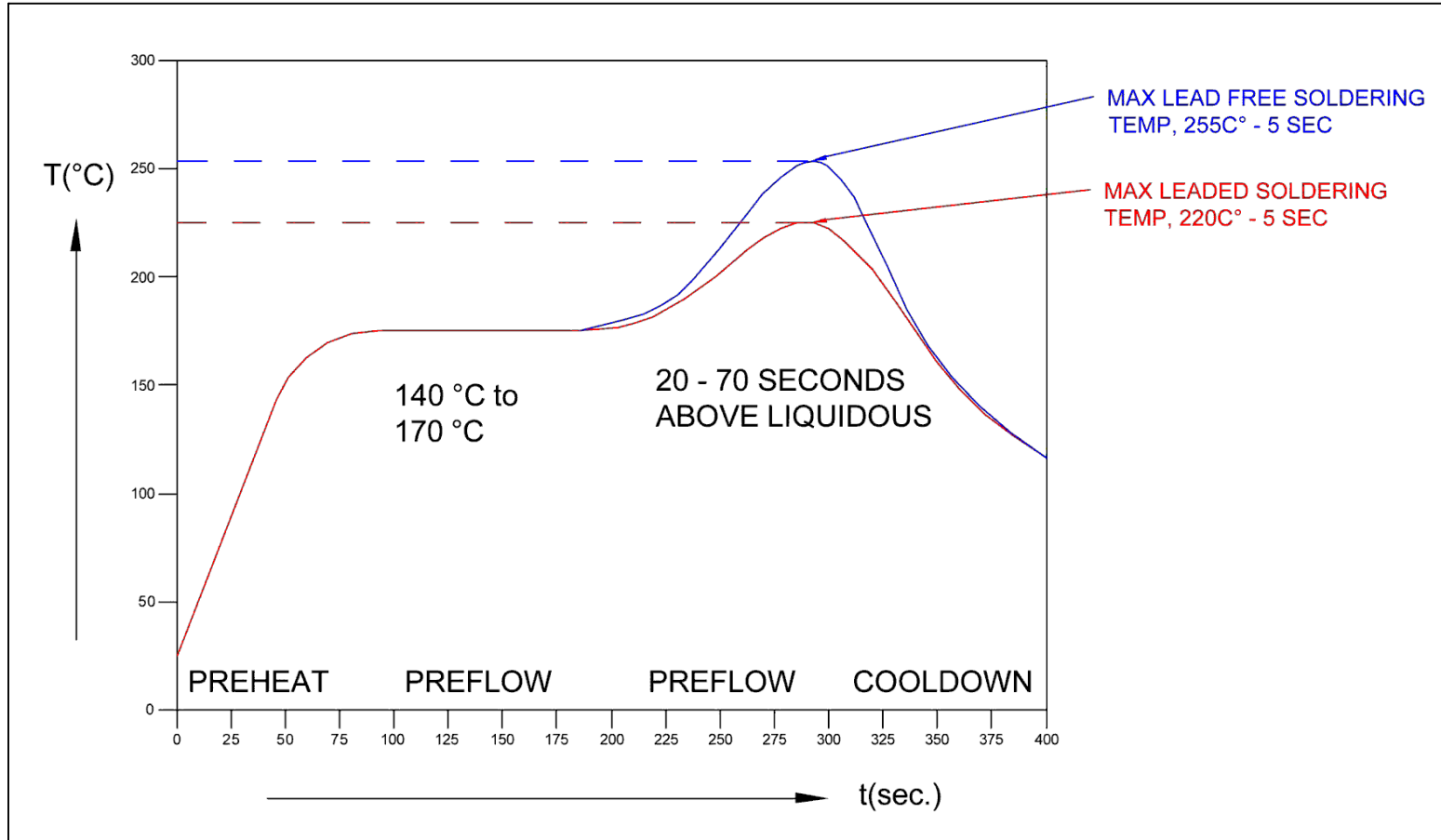

**NOTE:**  
 1. Do not clean after soldering. Only use no-clean solder paste.

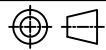
STANDARD TOLERANCE ( UNLESS OTHERWISE SPECIFIED )		<b>BIVAR</b> <sup>®</sup> 4 THOMAS, IRVINE, CA. 92618 TEL: (949) 951-8808 FAX: (949) 951-3974	
DECIMALS	ANGULAR		
.X ± .1	X° ± 1°	 <b>TITLE:</b> SMT FLP VERTICAL ADAPTER BI-COLOR, YELLOW/GREEN	
.XX ± .02			
.XXX ± .010			
DESIGNED: <b>A. Wright</b>	DATE: <b>03/13/14</b>	<b>PART NO:</b> SMTV01-YXXGXX	REVISION: <b>D</b>
CHECKED: <b>B. Oliver</b>	DATE: <b>03/13/14</b>	<b>CAGE CODE :</b> 32559	<b>SHEET #</b> 3 <b>OF</b> 4
CAD GENERATED DOCUMENT. DO NOT MEASURE DRAWING.			

REV.	DESCRIPTION	DATE	APPROVED
	SEE SHEET #1		

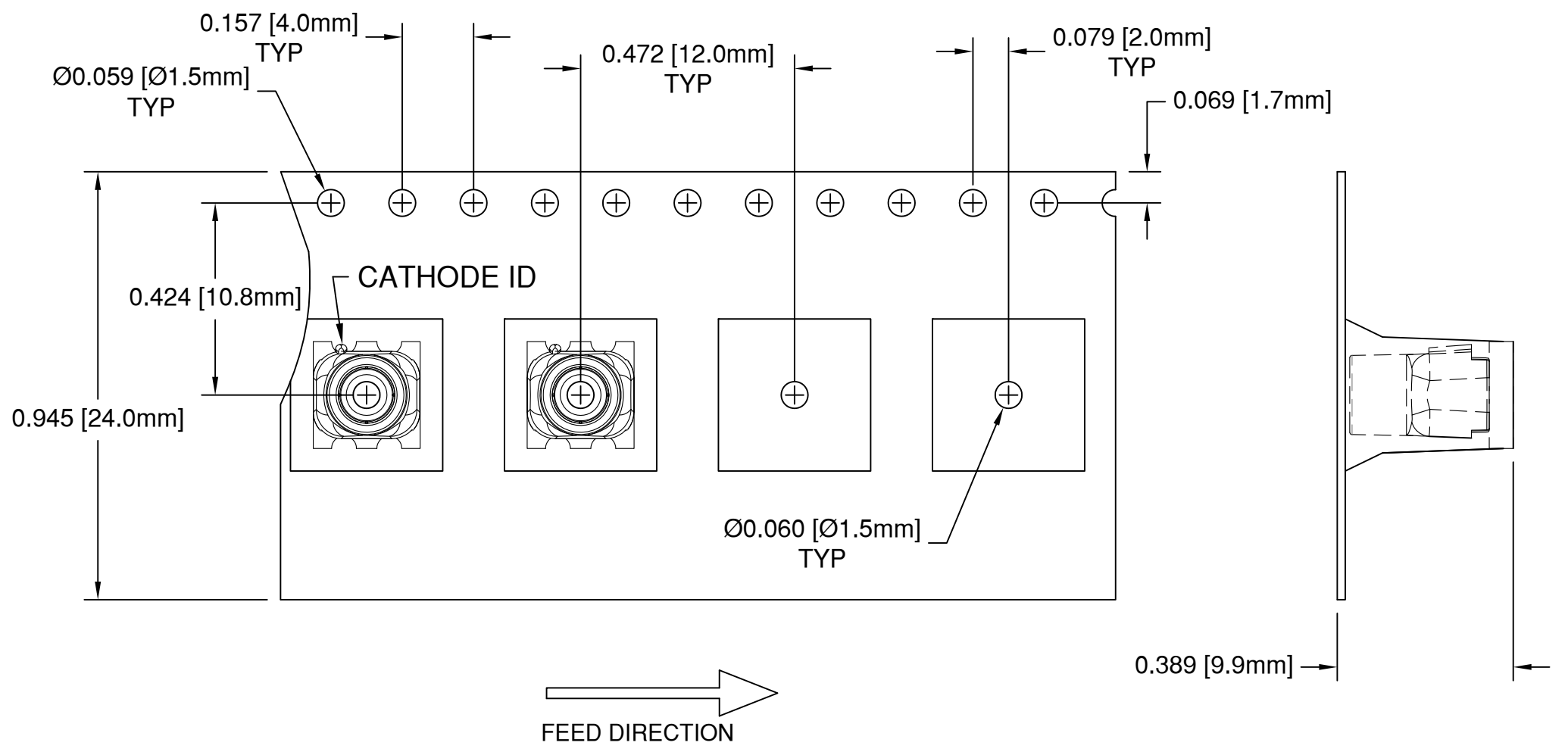

NOTES:  
 3. MOISTURE SENSITIVITY LEVEL: 4  
 2. UNLESS OTHERWISE SPECIFIED, PACKAGING TO COMPLY WITH EIA-481-D  
 1. 500 pcs PER REEL

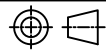
STANDARD TOLERANCE (UNLESS OTHERWISE SPECIFIED)		 4 THOMAS, IRVINE, CA. 92618 TEL: (949) 951-8808 FAX: (949) 951-3974	
DECIMALS	ANGULAR		
.X ± .1	X° ± 1°		TITLE: SMT FLP VERTICAL ADAPTER BI-COLOR, YELLOW/GREEN
.XX ± .02			PART NO: SMTV01-YXXGXX
.XXX ± .010			REVISION: D
DESIGNED: <b>A. Wright</b>	DATE: <b>03/13/14</b>	CAGE CODE : 32559	SHEET # 4 OF 4
CHECKED: <b>B. Oliver</b>	DATE: <b>03/13/14</b>	CAD GENERATED DOCUMENT. DO NOT MEASURE DRAWING.	