

SERPAC 252i (3D exploded)

Electronic Enclosures

- Click on image to show toolbar. Use ▶ || to Play/Pause Animation.
- Left click and drag on image to move 3D model.

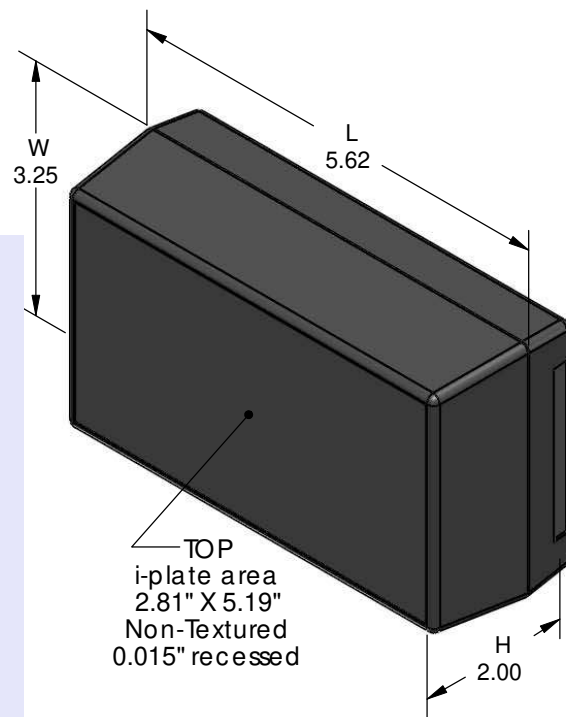
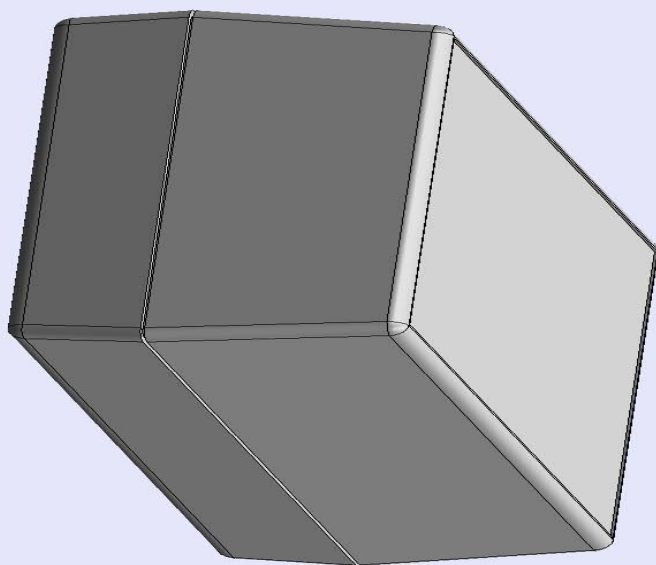

- a) Zoom in & out with center wheel.
- b) Pause at any moment to view and or print views.
- c) Change the views to ortho and section views if needed from the Views pull down menu.
- d) Explore options included in the tool bar like: Views, Transparency of model, Lighting type, etc.

Notes: (Enclosure weight 0.29 lb / 130 gm)

1) Enclosure meets or exceeds IP40 and NEMA 1

2) Circuit Board drawings can be download at:

Top:

http://www.serpac.com/Accessories/CircuitBoard/drawings/X53_CB.pdf

Bottom:

<http://www.serpac.com/Accessories/CircuitBoard/drawings/359-459-cbg.pdf>

3) All components are RoHS compliant.

PART NO.	DESCRIPTION (Included)	ACCESSORIES (Optional)	
PART NO.		PART NO.	DESCRIPTION
5-2i	TOP		
25	BOTTOM	359	Prototype grid board (bottom)
1025	Battery Cover	459	Prototype clad board (bottom)
6005	#4 X 3/8" Self tapping (4)	50	Non-skid feet

ALL DIMENSIONS ARE ±.010" 4/12/10 (1 of 2)
619 Commercial Ave. Covina, CA 91723

Ph. (626) 331-0517 Fx. (626) 331-8584 [serpac.com](http://www.serpac.com)

SERPAC 252i (user print)

Electronic Enclosures

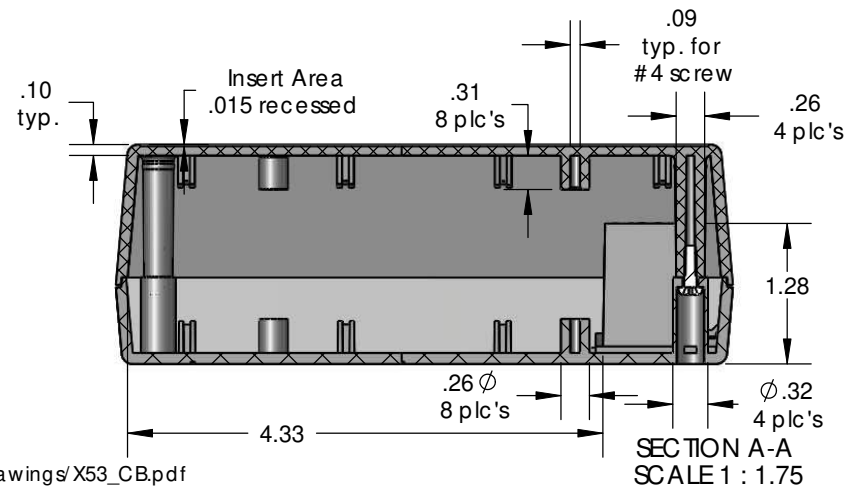
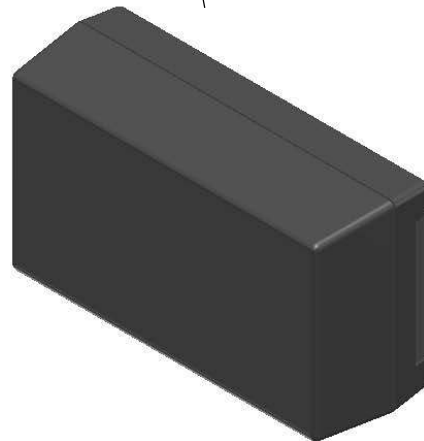
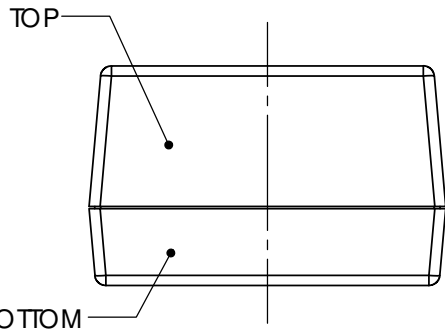
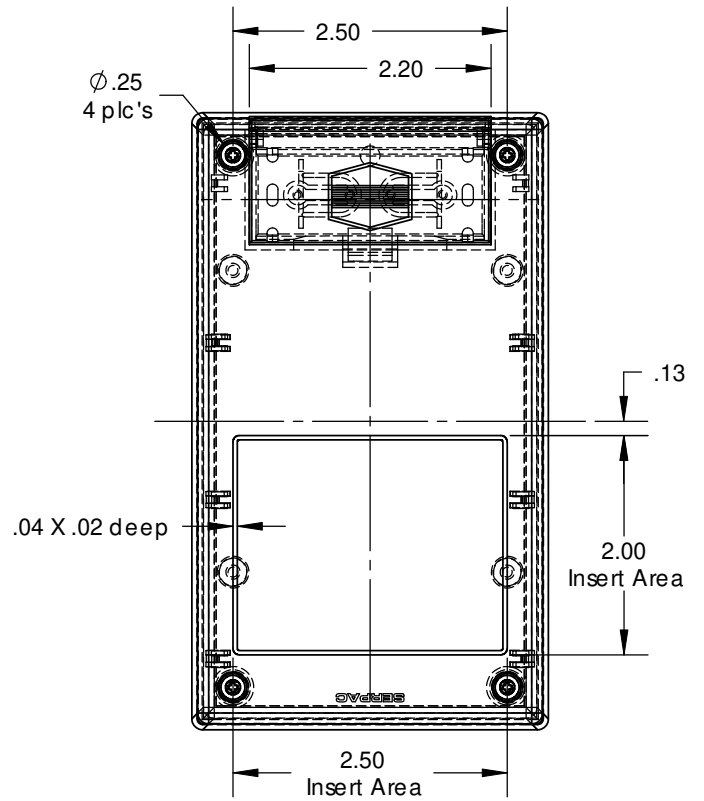
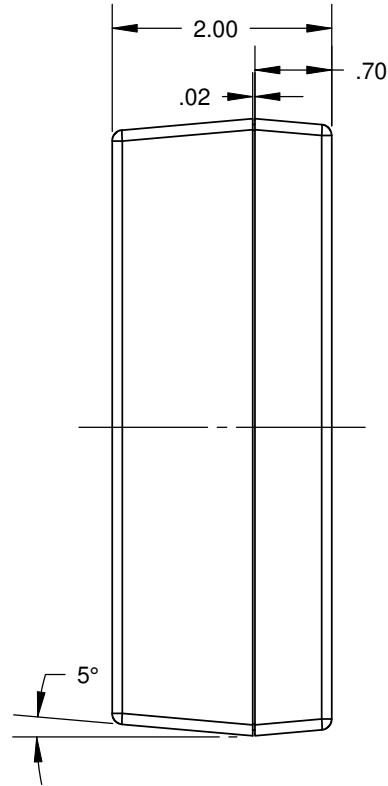
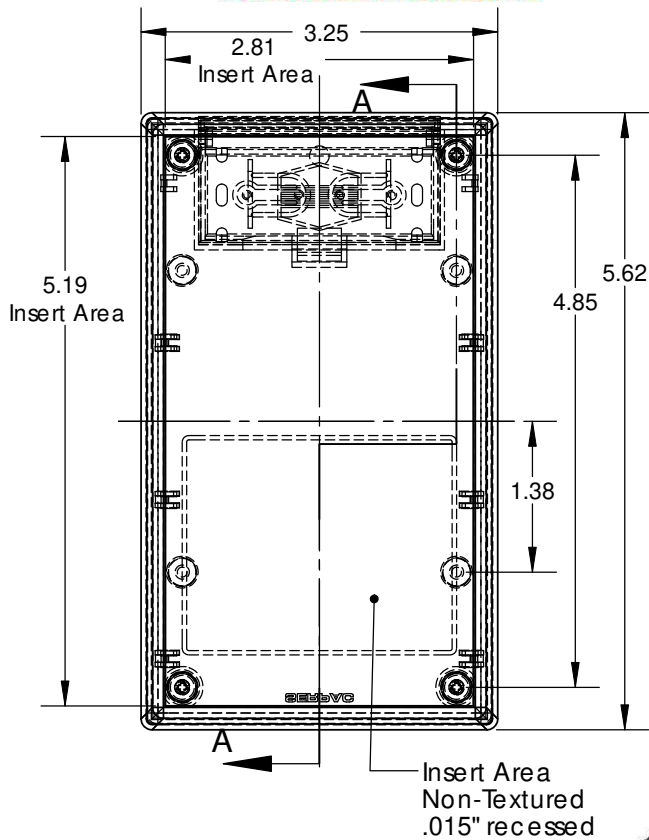

Notes: (Enclosure weight 0.29 lb / 130 gm)

- 1) Enclosure meets or exceeds IP40 and NEMA 1
- 2) Circuit Board drawings can be download at:

Top: http://www.serpac.com/Accessories/CircuitBoard/drawings/X53_CB.pdf

Bottom: <http://www.serpac.com/Accessories/CircuitBoard/drawings/359-459-cbg.pdf>

- 3) All components are RoHS Compliant.

PART NO.	DESCRIPTION (Included)	ACCESSORIES (Optional)	
5-2i	TOP	PART NO.	DESCRIPTION
25	BOTTOM	359	Prototype grid board (bottom)
1025	Battery Cover	459	Prototype clad board (bottom)
6005	#4X3/8" self tapping (4)	50	Non-skid feet

ALL DIMENSIONS ARE ± .010" 4/12/10 (2 of 2)
619 Commercial Ave. Covina, CA 91723

Ph. (626) 331-0517 Fx. (626) 331-8584 www.serpac.com