

Differential Amplifier Evaluation Board for Single 16-lead 3 mm × 3 mm LFCSP Packages

FEATURES

Flexible board layout

Accommodates the ADA492x-1 and ADA493x-1

family of differential amplifiers

Allows for various circuit configurations

Enables quick breadboarding/prototyping

Edge-mounted circuit configuration

Easy connection to test equipment and other circuits

RoHS compliant

GENERAL DESCRIPTION

The Analog Devices, Inc., differential driver evaluation board makes it easy for designers to obtain quick performance results for their particular differential driver application circuits. The board layout is very flexible and allows for many circuit configurations, including traditional four-resistor circuits, circuits with two different feedback loops, circuits with input and output transformers, filters, and many others. Most resistors and capacitors use 0603 and 0508 packages.

The evaluation board part number labeling does not contain any specific differential amplifier part number information because this is a universal evaluation board and can be used with any Analog Devices differential amplifier in a 16-lead, 3 mm × 3 mm LFCSP with a dedicated feedback pin.

The board accommodates the ADA492x-1 and ADA493x-1 family of differential amplifiers. The data sheets for these devices should be consulted in conjunction with this evaluation board user guide.

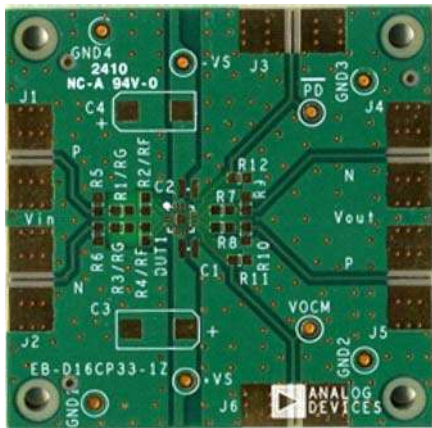

Figure 1. Component Side (LFCSP)

08950-003

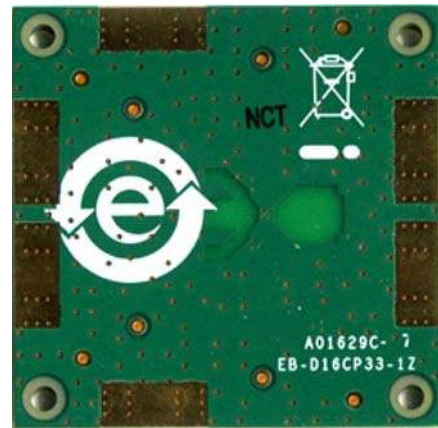

Figure 2. Circuit Side (LFCSP)

08950-003

TABLE OF CONTENTS

Features	1	V _{OCM} Input.....	4
General Description	1	Common-Mode Voltage.....	4
Revision History	2	SMA Input/Output Connectors	4
Differential Driver Evaluation Board Schematic.....	3	Evaluation Board Layout	5
Evaluation Board Hardware.....	4	Ordering Information.....	6
Power Supplies	4	Bill of Materials.....	6
Feedback Networks and Input/Output Terminations	4	Related Links.....	6

REVISION HISTORY

10/10—Revision 0: Initial Version

DIFFERENTIAL DRIVER EVALUATION BOARD SCHEMATIC

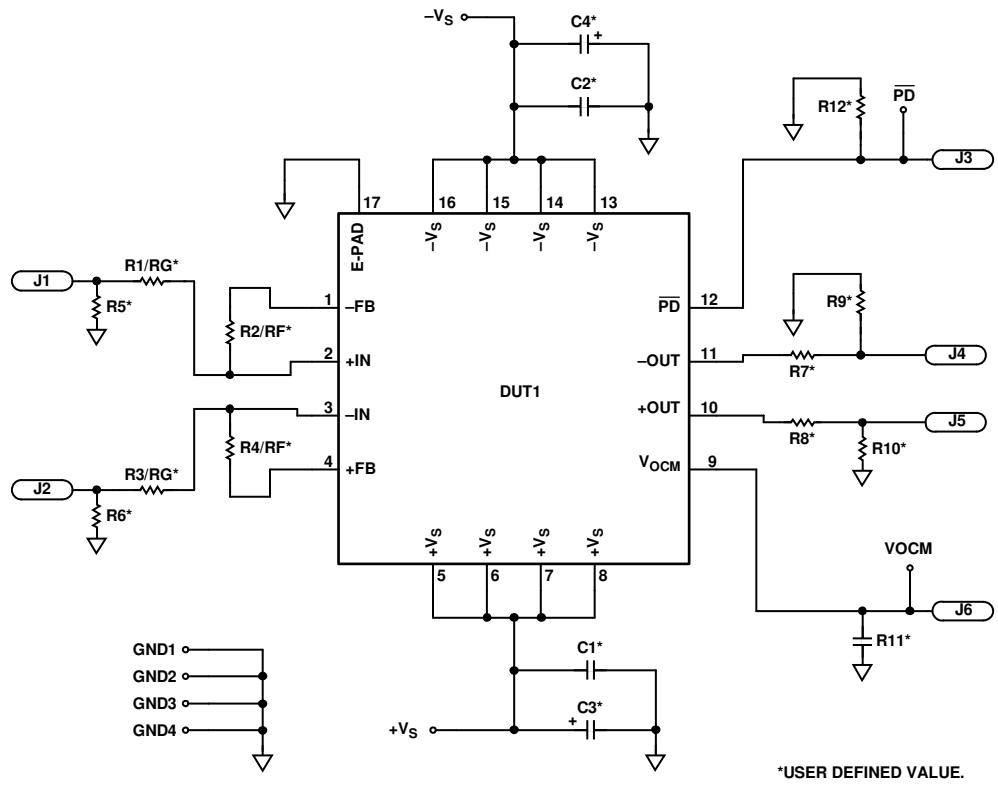

Figure 3. Differential Driver Evaluation Board Schematic

018990-001

EVALUATION BOARD HARDWARE

POWER SUPPLIES

Power is applied to the board through test pins $+V_S$ and $-V_S$ (see Figure 3). The board accommodates single or dual supplies. For single-supply operation, connect the negative supply to the ground plane.

It is very important that the power supply pins of the device under test (DUT) have broadband decoupling circuitry. The board layout facilitates this with footprints for a 0508 ceramic capacitor C1 and C2) on each supply. Bulk decoupling is provided by C3 and C4; 10 μ F tantalum capacitors are recommended.

FEEDBACK NETWORKS AND INPUT/OUTPUT TERMINATIONS

R1/RG and R2/RF comprise the upper resistive feedback loop (see Figure 3), and R3/RG and R4/RF compose the lower feedback loop. To minimize summing node capacitances, the ground plane under and around Pin 1 and Pin 8 of the DUT (see Figure 3) and the copper that connects to them have been removed.

R5 and R6 are included as input termination resistors for applications that have single-ended inputs.

V_{OCM} INPUT

An external voltage can be applied to V_{OCM} via J6 (referenced to the ground plane of the board). In ADC driving applications, it is convenient to apply the ADC dc reference voltage output directly to J6. The R11 component position can be used for both resistors and capacitors. A 0.1 μ F capacitor is used in normal applications to provide bypassing for the dc voltage applied to the V_{OCM} pin.

It is also possible to drive the V_{OCM} input from an external ac source. In this case, omit R11 or reduce it to a value that allows the desired signal to be passed.

COMMON-MODE VOLTAGE

The internal common-mode feedback loop used in the differential drivers forces the output common-mode voltage to be equal to the voltage applied to the V_{OCM} input, thereby providing excellent output balance.

SMA INPUT/OUTPUT CONNECTORS

The inputs and outputs have edge-mounted SMA connectors for convenient connection to coaxial cables. The recommended connector type is Johnson Components™, Part Number 142-0701-801 or equivalent.

EVALUATION BOARD LAYOUT

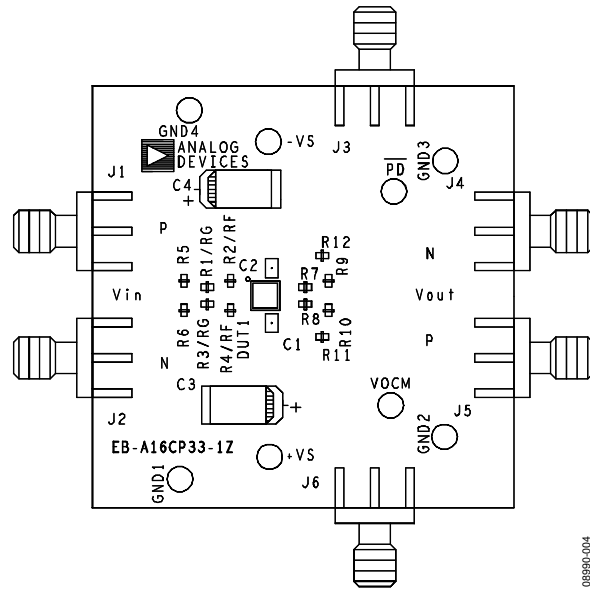

Figure 4. Assembly Drawing Component Side

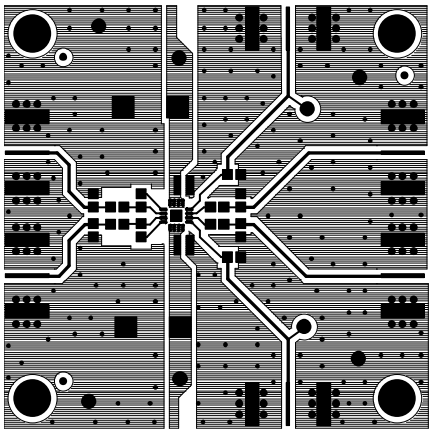

Figure 5. Component Side Metallization (LFCS)

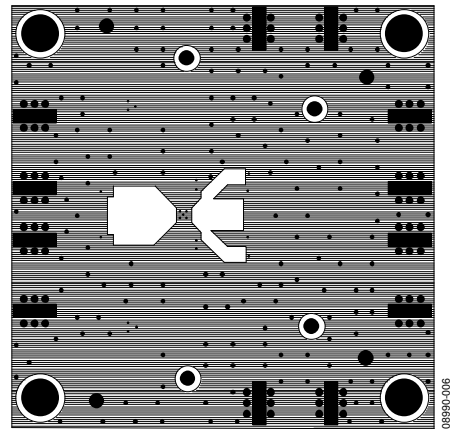

Figure 6. Circuit Side Metallization (LFCS)

ORDERING INFORMATION**BILL OF MATERIALS**

Table 1.

Qty	Reference Designator	Package	Description
2	C3, C4	C7343	10 μ F capacitor
2	C1, C2	C0508	Capacitor, 0.1uF
6	J1 to J6	SMASMT	SMA connector
12	R1/RG, R2/RF, R3/RG, R4/RF, R5 to R12	R0603	Resistor, user defined value
8	+V _S , -V _S , PD/DIS, V _{OCM} , GND1 to GND4	TP1	Test point
1	DUT1	16-lead LFCSP	Device under test
1			PC board

RELATED LINKS

Table 2.

Resource	Description
ADA4927-1	Product page, ultralow distortion current feedback differential ADC driver
ADA4930-1	Product page, ultralow noise driver for low voltage ADCs
ADA4932-1	Product page, low power differential ADC driver
ADA4937-1	Product page, single supply ultralow distortion differential ADC driver
ADA4938-1	Product page, ultralow distortion differential ADC driver
ADA4939-1	Product page, G > 2 ultralow distortion differential ADC driver

NOTES

NOTES

**ESD Caution**

ESD (electrostatic discharge) sensitive device. Charged devices and circuit boards can discharge without detection. Although this product features patented or proprietary protection circuitry, damage may occur on devices subjected to high energy ESD. Therefore, proper ESD precautions should be taken to avoid performance degradation or loss of functionality.

Legal Terms and Conditions

By using the evaluation board discussed herein (together with any tools, components documentation or support materials, the "Evaluation Board"), you are agreeing to be bound by the terms and conditions set forth below ("Agreement") unless you have purchased the Evaluation Board, in which case the Analog Devices Standard Terms and Conditions of Sale shall govern. Do not use the Evaluation Board until you have read and agreed to the Agreement. Your use of the Evaluation Board shall signify your acceptance of the Agreement. This Agreement is made by and between you ("Customer") and Analog Devices, Inc. ("ADI"), with its principal place of business at One Technology Way, Norwood, MA 02062, USA. Subject to the terms and conditions of the Agreement, ADI hereby grants to Customer a free, limited, personal, temporary, non-exclusive, non-sublicensable, non-transferable license to use the Evaluation Board FOR EVALUATION PURPOSES ONLY. Customer understands and agrees that the Evaluation Board is provided for the sole and exclusive purpose referenced above, and agrees not to use the Evaluation Board for any other purpose. Furthermore, the license granted is expressly made subject to the following additional limitations: Customer shall not (i) rent, lease, display, sell, transfer, assign, sublicense, or distribute the Evaluation Board; and (ii) permit any Third Party to access the Evaluation Board. As used herein, the term "Third Party" includes any entity other than ADI, Customer, their employees, affiliates and in-house consultants. The Evaluation Board is NOT sold to Customer; all rights not expressly granted herein, including ownership of the Evaluation Board, are reserved by ADI. CONFIDENTIALITY. This Agreement and the Evaluation Board shall all be considered the confidential and proprietary information of ADI. Customer may not disclose or transfer any portion of the Evaluation Board to any other party for any reason. Upon discontinuation of use of the Evaluation Board or termination of this Agreement, Customer agrees to promptly return the Evaluation Board to ADI. ADDITIONAL RESTRICTIONS. Customer may not disassemble, decompile or reverse engineer chips on the Evaluation Board. Customer shall inform ADI of any occurred damages or any modifications or alterations it makes to the Evaluation Board, including but not limited to soldering or any other activity that affects the material content of the Evaluation Board. Modifications to the Evaluation Board must comply with applicable law, including but not limited to the RoHS Directive. TERMINATION. ADI may terminate this Agreement at any time upon giving written notice to Customer. Customer agrees to return to ADI the Evaluation Board at that time. LIMITATION OF LIABILITY. THE EVALUATION BOARD PROVIDED HEREUNDER IS PROVIDED "AS IS" AND ADI MAKES NO WARRANTIES OR REPRESENTATIONS OF ANY KIND WITH RESPECT TO IT. ADI SPECIFICALLY DISCLAIMS ANY REPRESENTATIONS, ENDORSEMENTS, GUARANTEES, OR WARRANTIES, EXPRESS OR IMPLIED, RELATED TO THE EVALUATION BOARD INCLUDING, BUT NOT LIMITED TO, THE IMPLIED WARRANTY OF MERCHANTABILITY, TITLE, FITNESS FOR A PARTICULAR PURPOSE OR NON-INFRINGEMENT OF INTELLECTUAL PROPERTY RIGHTS. IN NO EVENT WILL ADI AND ITS LICENSORS BE LIABLE FOR ANY INCIDENTAL, SPECIAL, INDIRECT, OR CONSEQUENTIAL DAMAGES RESULTING FROM CUSTOMER'S POSSESSION OR USE OF THE EVALUATION BOARD, INCLUDING BUT NOT LIMITED TO LOST PROFITS, DELAY COSTS, LABOR COSTS OR LOSS OF GOODWILL. ADI'S TOTAL LIABILITY FROM ANY AND ALL CAUSES SHALL BE LIMITED TO THE AMOUNT OF ONE HUNDRED US DOLLARS (\$100.00). EXPORT. Customer agrees that it will not directly or indirectly export the Evaluation Board to another country, and that it will comply with all applicable United States federal laws and regulations relating to exports. GOVERNING LAW. This Agreement shall be governed by and construed in accordance with the substantive laws of the Commonwealth of Massachusetts (excluding conflict of law rules). Any legal action regarding this Agreement will be heard in the state or federal courts having jurisdiction in Suffolk County, Massachusetts, and Customer hereby submits to the personal jurisdiction and venue of such courts. The United Nations Convention on Contracts for the International Sale of Goods shall not apply to this Agreement and is expressly disclaimed.