

# SPECIFICATIONS

PARAMETERS	VALUES	UNITS
RATED VOLTAGE	32	Vdc
OPERATING VOLTAGE RANGE	3 ~ 32	Vdc
RATED CURRENT (MAX)	22	mA
MINIMUM SPL @ 10 CM	105	dB
RESONANT FREQUENCY	2,800 ± 500	Hz
TONE OR PULSE RATE	CONTINUOUS	0 pulse /sec
OPERATING TEMPERATURE	-30 ~ +80	°C
STORAGE TEMPERATURE	-40 ~ +80	°C
HOUSING MATERIAL	UL94 ABS	-
TERMINAL MATERIAL	Sn PLATED BRONZE	-
WEIGHT	16	grams

THIS DOCUMENT CONTAINS DATA PROPRIETARY TO PROJECTS UNLIMITED, INC. ANY USE OR REPRODUCTION, IN ANY FORM, WITHOUT PRIOR WRITTEN PERMISSION OF PROJECTS UNLIMITED, INC. IS PROHIBITED.  
©2003, Projects Unlimited Inc.

# REVISION HISTORY

LTR	DESCRIPTION	DATE	APPROVED
-	RELEASED FROM ENGINEERING	1/24/2006	
A	REVISED TO INVENTOR 3-D DRAWING TEMPLATE	6/1/2010	B.R.
B	REVISED PIN LENGTH TO 8.5mm	9/25/2015	M.L.
C	REVISED WEIGHT	2/26/2020	M.V.

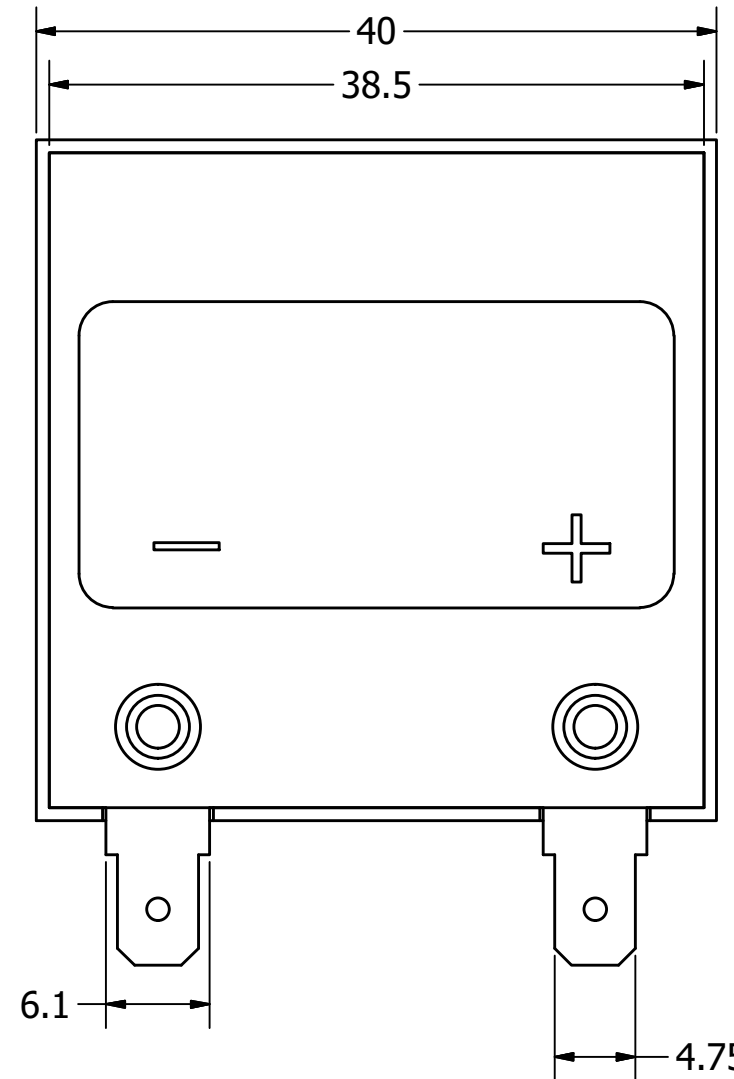
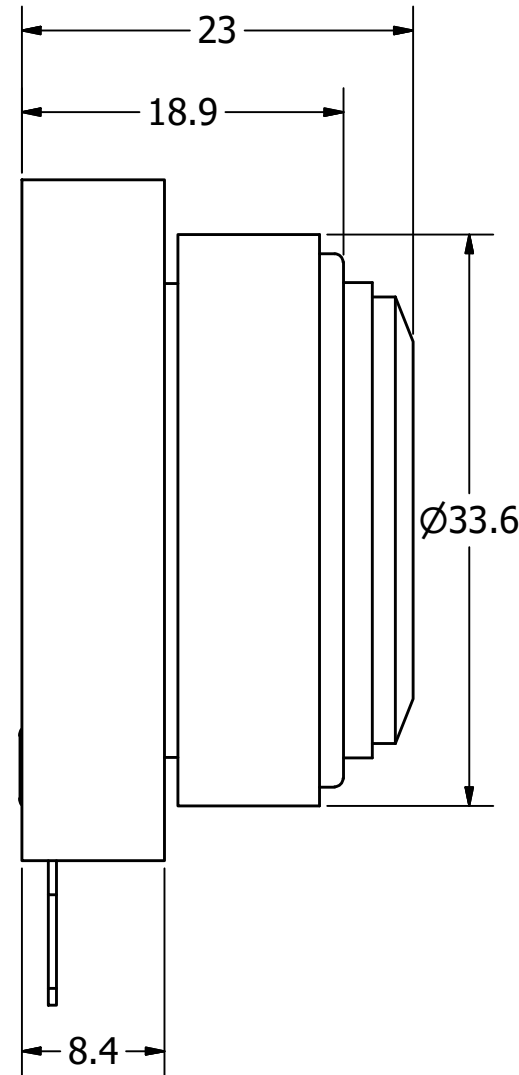
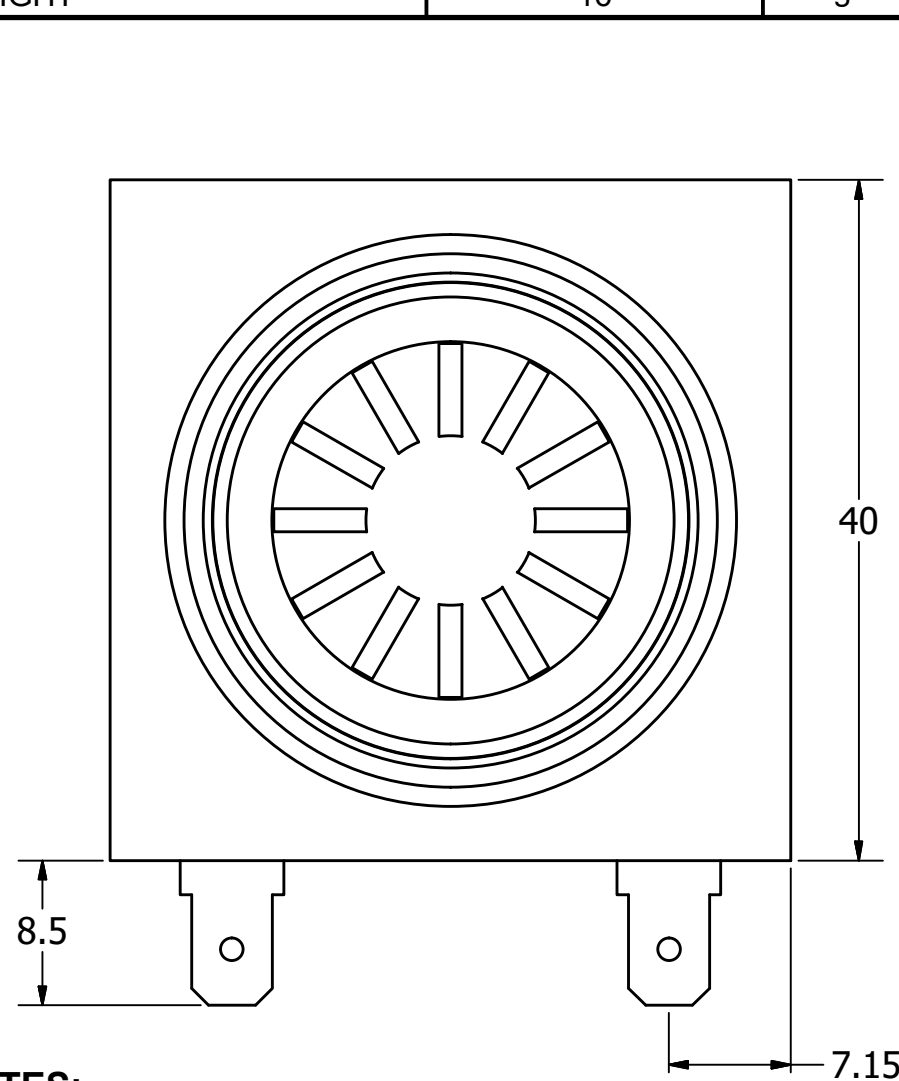
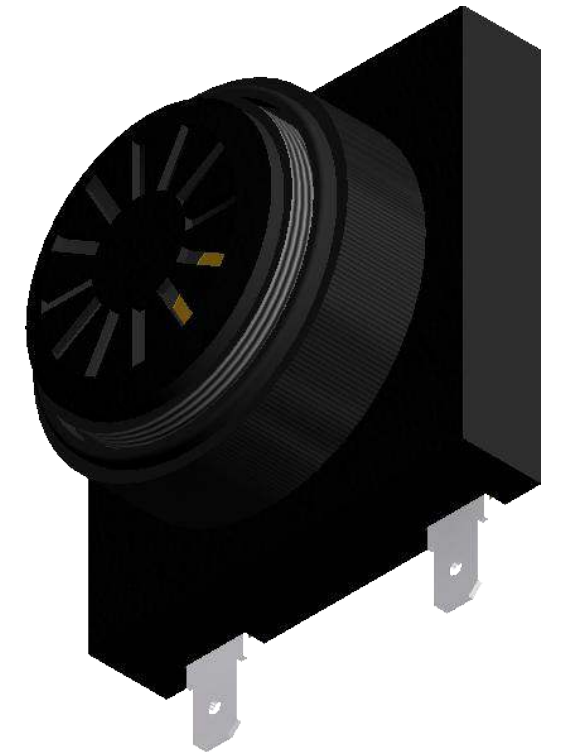

### NOTES:

1. ALL DIMENSIONS ARE IN MILLIMETERS.
2. SPECIFICATIONS SUBJECT TO CHANGE OR WITHDRAWL WITHOUT NOTICE.
3. RECOMMENDED PANEL HOLE IS 28MM ± 0.2MM.
4. THIS PART IS RoHS 2011/65/EU COMPLIANT.

UNLESS OTHERWISE SPECIFIED: DIMENSIONS ARE IN MILLIMETERS, TOLERANCES ARE ±0.5 AND ANGLES ARE ±3°.	SIZE <b>A3</b>	Designed by	Date	Checked by	Date	Approved by	Date	Drawn Date
		J.A.F.	1/24/2006	E.P.	1/24/2006	B.R.	1/24/2006	6/1/2010
X-4028-P-C32-R.idw				<b>X-4028-P-C32-R</b> Indicator				
				Edition		Sheet		
				-		1 / 1		