



MB39C031-EVB-01

2ch Buck DC/DC + LDO with I²C Interface Evaluation Board Operation Guide

Doc. No. 002-08673 Rev. *C

Cypress Semiconductor
198 Champion Court
San Jose, CA 95134-1709
www.cypress.com

© Cypress Semiconductor Corporation, 2014-2018. This document is the property of Cypress Semiconductor Corporation and its subsidiaries, including Spansion LLC (“Cypress”). This document, including any software or firmware included or referenced in this document (“Software”), is owned by Cypress under the intellectual property laws and treaties of the United States and other countries worldwide. Cypress reserves all rights under such laws and treaties and does not, except as specifically stated in this paragraph, grant any license under its patents, copyrights, trademarks, or other intellectual property rights. If the Software is not accompanied by a license agreement and you do not otherwise have a written agreement with Cypress governing the use of the Software, then Cypress hereby grants you a personal, non-exclusive, nontransferable license (without the right to sublicense) (1) under its copyright rights in the Software (a) for Software provided in source code form, to modify and reproduce the Software solely for use with Cypress hardware products, only internally within your organization, and (b) to distribute the Software in binary code form externally to end users (either directly or indirectly through resellers and distributors), solely for use on Cypress hardware product units, and (2) under those claims of Cypress’s patents that are infringed by the Software (as provided by Cypress, unmodified) to make, use, distribute, and import the Software solely for use with Cypress hardware products. Any other use, reproduction, modification, translation, or compilation of the Software is prohibited.

TO THE EXTENT PERMITTED BY APPLICABLE LAW, CYPRESS MAKES NO WARRANTY OF ANY KIND, EXPRESS OR IMPLIED, WITH REGARD TO THIS DOCUMENT OR ANY SOFTWARE OR ACCOMPANYING HARDWARE, INCLUDING, BUT NOT LIMITED TO, THE IMPLIED WARRANTIES OF MERCHANTABILITY AND FITNESS FOR A PARTICULAR PURPOSE. No computing device can be absolutely secure. Therefore, despite security measures implemented in Cypress hardware or software products, Cypress does not assume any liability arising out of any security breach, such as unauthorized access to or use of a Cypress product. In addition, the products described in these materials may contain design defects or errors known as errata which may cause the product to deviate from published specifications. To the extent permitted by applicable law, Cypress reserves the right to make changes to this document without further notice. Cypress does not assume any liability arising out of the application or use of any product or circuit described in this document. Any information provided in this document, including any sample design information or programming code, is provided only for reference purposes. It is the responsibility of the user of this document to properly design, program, and test the functionality and safety of any application made of this information and any resulting product. Cypress products are not designed, intended, or authorized for use as critical components in systems designed or intended for the operation of weapons, weapons systems, nuclear installations, life-support devices or systems, other medical devices or systems (including resuscitation equipment and surgical implants), pollution control or hazardous substances management, or other uses where the failure of the device or system could cause personal injury, death, or property damage (“Unintended Uses”). A critical component is any component of a device or system whose failure to perform can be reasonably expected to cause the failure of the device or system, or to affect its safety or effectiveness. Cypress is not liable, in whole or in part, and you shall and hereby do release Cypress from any claim, damage, or other liability arising from or related to all Unintended Uses of Cypress products. You shall indemnify and hold Cypress harmless from and against all claims, costs, damages, and other liabilities, including claims for personal injury or death, arising from or related to any Unintended Uses of Cypress products.

Cypress, the Cypress logo, Spansion, the Spansion logo, and combinations thereof, WICED, PSoC, CapSense, EZ-USB, F-RAM, and Traveo are trademarks or registered trademarks of Cypress in the United States and other countries. For a more complete list of Cypress trademarks, visit cypress.com. Other names and brands may be claimed as property of their respective owners.

Arm and Cortex are registered trademarks of Arm Limited (or its subsidiaries) in the US and/or elsewhere.

Preface



This manual explains how to use the evaluation board. Be sure to read this manual before using the product. For this product, please consult with sales representatives or support representatives.

Handling and use

Handling and use of this product and notes regarding its safe use are described in the manuals.

Follow the instructions in the manuals to use this product.

Keep this manual at hand so that you can refer to it anytime during use of this product.

Notice on this document

All information included in this document is current as of the date it is issued. Such information is subject to change without any prior notice.

Please confirm the latest relevant information with the sales representatives.

Cautions



Caution of the products described in this document

The following precautions apply to the product described in this manual.

 WARNING	Indicates a potentially hazardous situation which could result in death or serious injury and/or a fault in the user's system if the product is not used correctly.
--	---

Electric shock, Damage	Before performing any operation described in this manual, turn off all the power supplies to the system. Performing such an operation with the power on may cause an electric shock or device fault.
Electric shock, Damage	Once the product has been turned on, do not touch any metal part of it. Doing so may cause an electric shock or device fault.

 CAUTION	Indicates the presence of a hazard that may cause a minor or moderate injury, damages to this product or devices connected to it, or may cause to lose software resources and other properties such as data, if the device is not used appropriately.
--	---

Cuts, Damage	Before moving the product, be sure to turn off all the power supplies and unplug the cables. Watch your step when carrying the product. Do not use the product in an unstable location such as a place exposed to strong vibration or a sloping surface. Doing so may cause the product to fall, resulting in an injury or fault.
Cuts	The product contains sharp edges that are left unavoidably exposed, such as jumper plugs. Handle the product with due care not to get injured with such pointed parts.
Damage	Do not place anything on the product or expose the product to physical shocks. Do not carry the product after the power has been turned on. Doing so may cause a malfunction due to overloading or shock.
Damage	Since the product contains many electronic components, keep it away from direct sunlight, high temperature, and high humidity to prevent condensation. Do not use or store the product where it is exposed to much dust or a strong magnetic or electric field for an extended period of time. Inappropriate operating or storage environments may cause a fault.
Damage	Use the product within the ranges given in the specifications. Operation over the specified ranges may cause a fault.
Damage	To prevent electrostatic breakdown, do not let your finger or other object come into contact with the metal parts of any of the connectors. Before handling the product, touch a metal object (such as a door knob) to discharge any static electricity from your body.

Damage	When turning the power on or off, follow the relevant procedure as described in this document. Before turning the power on, in particular, be sure to finish making all the required connections. Furthermore, be sure to configure and use the product by following the instructions given in this document. Using the product incorrectly or inappropriately may cause a fault.
Damage	Always turn the power off before connecting or disconnecting any cables from the product. When unplugging a cable, unplug the cable by holding the connector part without pulling on the cable itself. Pulling the cable itself or bending it may expose or disconnect the cable core, resulting in a fault.
Damage	Because the product has no casing, it is recommended that it be stored in the original packaging. Transporting the product may cause a damage or fault. Therefore, keep the packaging materials and use them when re-shipping the product.

Contents



1. Description	7
2. Evaluation Board Specification	8
3. PIN Descriptions	9
3.1 Input/output Pin Descriptions	9
3.2 Jumper, Switch descriptions	10
4. Setup and Verification	12
4.1 Contents in a package	12
4.2 Evaluation with CTL (*1) switch	13
4.3 Evaluation with I ² C control	14
4.3.1 PC Setup	14
4.3.2 Operation check	15
4.3.3 How to use I ² C communication GUI	16
4.4 Specification of MB39C031	17
5. Component and Wiring Layout	18
5.1 Component Layout	18
5.2 Wiring layout	19
6. Circuit Schematic	23
7. Component List	25
8. Evaluation Board Picture	31
9. Ordering Information	33
Revision History	34
Document Revision History	34

1. Description



The MB39C031-EVB-01 is the evaluation board for 2ch Buck DC/DC + 1ch LDO, MB39C031. This board implements MB39C031: Option-code 342, and output preset voltage DD1:1.2V, DD2:1.8V, LDO:3.3V or selectable voltage controlled by I²C communication. This board implements our MCU : FM3(MB9AF312K) and can select the soft-start time, ON/OFF sequence, PFM/PWM mode easily with I²C communication using windows PC and prepared software.

Figure 1-1. Board Outline

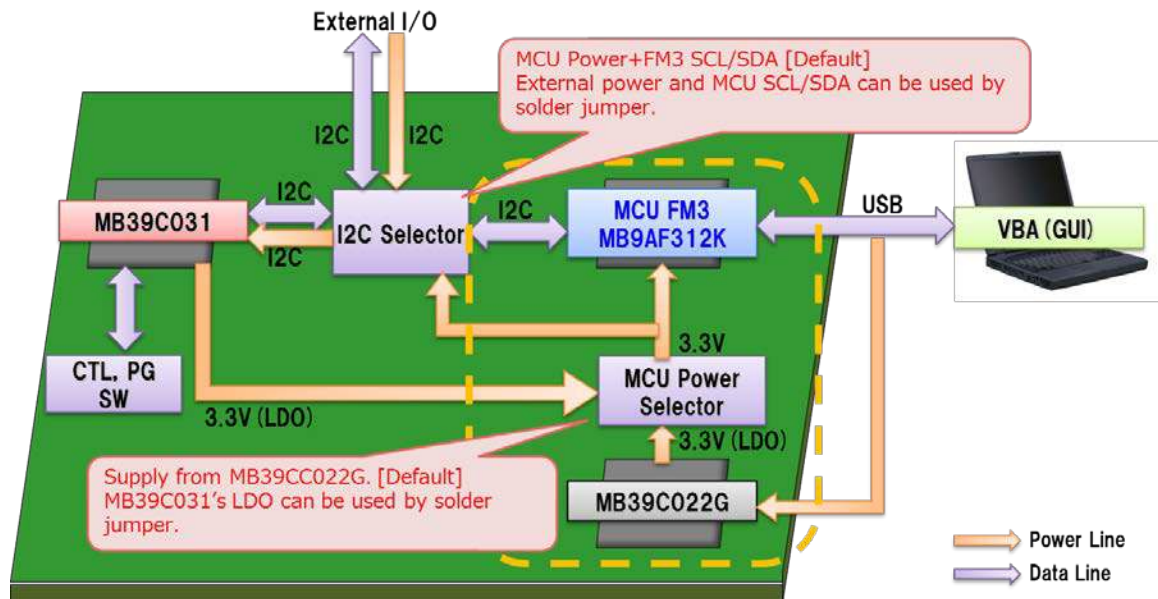

2. Evaluation Board Specification



Table 2-1. Evaluation Board Specification

Item	Symbol	Min	Typ	Max	Unit
Input voltage	VIN	2.5	3.6	5.5	V
Output voltage	Vo1	1.19	1.20	1.21	V
Output current	Io1	-	-	1400	mA
Output voltage	Vo2	1.78	1.80	1.82	V
Output current	Io2	-	-	600	mA
Output voltage	LDO	3.24	3.30	3.36	V
Output current	Io3	-	-	250	mA

Board size : 80mm × 80mm

3. PIN Descriptions



3.1 Input/output Pin Descriptions

Table 3-1. Input/output Pin Descriptions

Block	Pin symbol	I/O	Function description
DD1	Vo1	O	DD1 output terminal
	PG1	O	DD1 POWERGOOD output monitor terminal
	Vo1_GND	O	DD1 ground terminal
DD2	Vo2	O	DD2 output terminal
	PG2	O	DD2 POWERGOOD output monitor terminal
	Vo2_GND	O	DD2 ground terminal
LDO	LDO	O	LDO output terminal
	PGL	O	LDO POWERGOOD output monitor terminal
	LDO_GND	O	LDO ground terminal
CTL	CTL1	I	DD1 control terminal
	CTL2	I	DD2 control terminal
	CTLL	I	LDO control terminal
	CTLMAIN	I	Control terminal for common block and MCU block
ERR	ERR	O	ERR signal output terminal
I ² C	VCCI2C	I	Power supply terminal for I ² C.
	SCL	I	I ² C clock terminal
	SDA	I/O	I ² C data I/O terminal
	ADDSEL	I	Switch terminal for slave address
COMMON	VIN	I	Control circuit block power supply terminal
	VREF	O	Reference voltage (2.4V) output terminal
	VR	O	Reference voltage (0.6V) output terminal
	GND	-	Control circuit block ground terminal
MCU	VBUS	O	VBUS output monitor
	3R3V	O	3R3V output monitor
	GND_1	-	GND for MCU
	GND_2	-	GND for MCU

3.2 Jumper, Switch descriptions

Table 3-2. Jumper, Switch Descriptions

Jumper, Switch	Description	Initial setting
JP1	Short VIN terminal and PVCC1 pin (power of DD1 block)	Short
JP2	Short Vo1 terminal and L1 inductor	Short
JP3	Short VIN terminal and R1 (Pull-up resistor for PG1 pin)	Short
JP4	Short VIN terminal and PVCC2 pin (power of DD2 block)	Short
JP5	Short Vo2 terminal and L2 inductor	Short
JP6	Short VIN terminal and R2 (Pull-up resistor for PG2 pin)	Short
JP7	Short VIN terminal and PVCC1 pin (power of LDO block)	Short
JP8	Short VIN terminal and R3 (Pull-up resistor for PGL pin)	Short
JP9	Short VIN terminal and R4 (Pull-up resistor for ERR pin)	Short
JP10 back side	Short VIN terminal and VCC_1 pin (power of common block)	Short
JP11 back side	Short VIN terminal and VCC_2 pin (power of common block)	Short
JP12	Short 3R3V terminal and VCCI2C pin	Short
JP13	Short SCL terminal and SCL pin	Short
JP14	Short SDA terminal and SDA pin	Short
JP15	Short SW1 and ADDSEL pin	Short
JP16	Short SW1 and CTLMAIN pin	Short
JP17	Short SW1 and CTL1 pin	Short
JP18	Short SW1 and CTL2 pin	Short
JP19	Short SW1 and CTLL pin	Short
JP101 back side	Short USB ID and MCU I/O port (30 pin)	Short
JP102	022 : 3.3V is supplied to 3R3V from MB39C022G LDO 031 : 3.3V is supplied to 3R3V from MB39C031 LDO	022
SW1	1 : ADDSEL=H at ON, ADDSEL=OPEN at OFF 2 : CTLMAIN=H at ON, CTLMAIN=OPEN at OFF 3 : CTL1=H at ON, CTL1=OPEN at OFF 4 : CTL2=H at ON, CTL2=OPEN at OFF 5 : CTLL=H at ON, CTLL=OPEN at OFF 6 : Unused	Short
SW101	Reset push switch for MCU	-
SW102	Test switch for MCU	OFF
CN1	1 : SCL pin 2 : SDA pin 3 : GND pin 4 : VCCI2C pin	-
CN2	1,7 : PG2 pin 2,4 : CTLL pin 3,9 : PG1 pin 5,11 : PGL pin 6,8 : CTL1 pin 10,12 : CTL2 pin	-

Jumper, Switch	Description	Initial setting
CN101	USB connector	-
CN102	JTAG connector for MCU	-
CN103	Expansion serial connector	-
CN104	Mode connector for MCU	-

4. Setup and Verification



4.1 Contents in a package

No.	Contents	Description	Quantity	Notes
1	MB39C031-EVBSK-01	Power management IC evaluation board	1	-
2	USB cable	USB to USB mini B cable	1	-

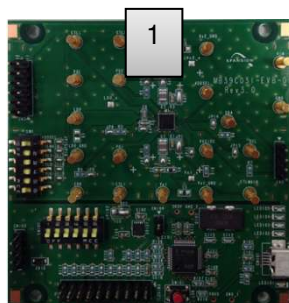

[Required item for evaluation of power block]

- MB39C031-EVB-01 1pic

- [Using items for evaluation with I²C control]
- MB39C031-EVB-01 1pic
- USB cable 1pic
- PC installed Windows7 or later OS 1pic

4.2 Evaluation with CTL (*1) switch

MB39C031 preset value can be evaluated with stabilized power supply.

*1: CTLMAIN, CTL1, CTL2, CTLL

1. 3.6V is applied to VIN terminal.
2. CTLMAIN, CTL1, CTL2, CTLL switch are turned on
3. Vo1:1.2V, Vo2:1.8V, LDO:3.3V is output.

Figure 4-1. For Control Switch Evaluation

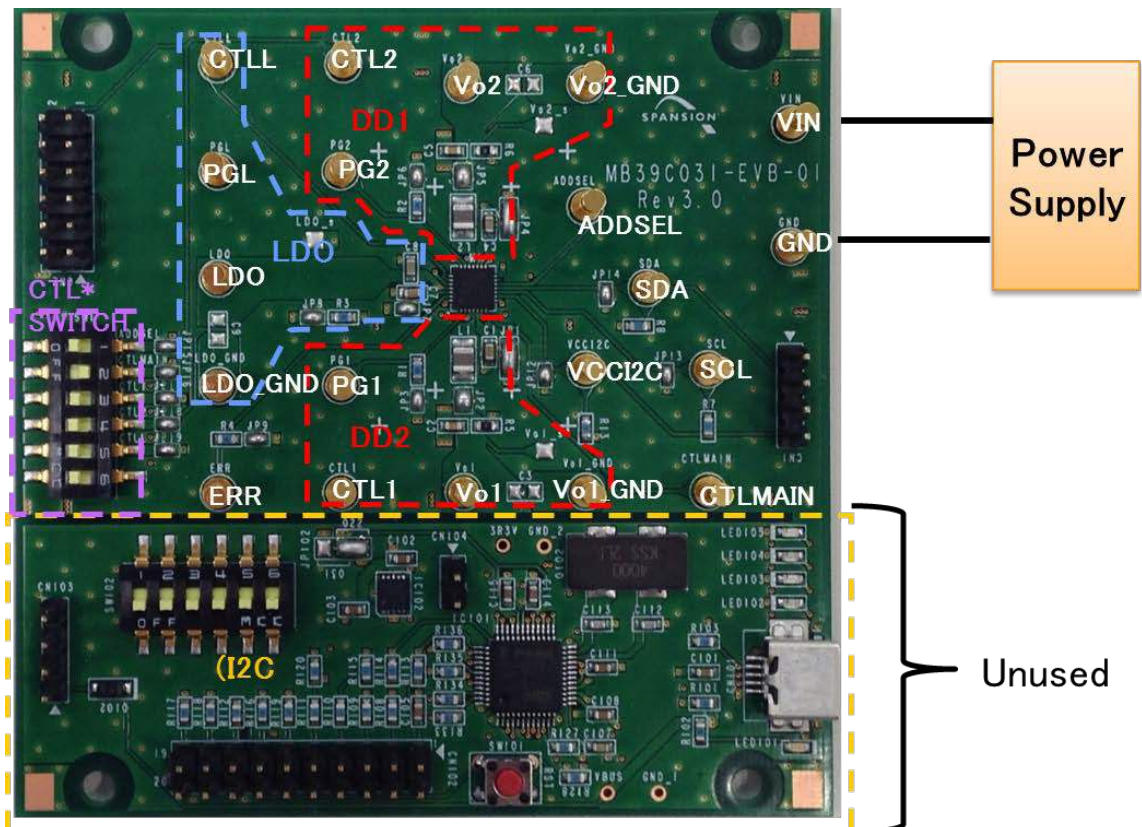

4.3 Evaluation with I²C control

All setting of MB39C031 can be evaluated with Windows PC connected to USB port by I²C communication GUI.

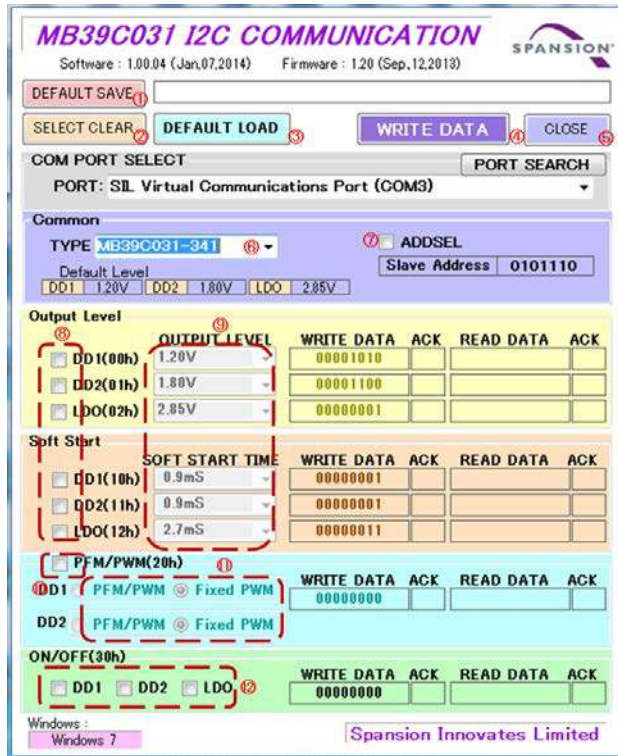

- ① : Save the setting data, which is shown next as default
- ② : Clear the of ⑧, ⑩, ⑫
- ③ : Reset the IC factory default
- ④ : Write the data to IC
- ⑤ : Close the window
- ⑥ : Select the preset option (ex. Select MB39C031-341)
- ⑦ : Select ADDSEL
- ⑧ : Set output voltage/soft star transfer
- ⑨ : Select the setting value after of ⑧
- ⑩ : Set PFM/PWM mode transfer
- ⑪ : Select PFM/PWM mode after of ⑩
- ⑫ : Set ON

4.3.1 PC Setup

1. Unpack the driver file to a folder of PC running Windows 7 or later version OS, and run install.bat file.
2. Connect MB39C031-EVB-01 to PC using USB cable.
3. After installed a device, open the device manager and confirm the new COM port.
Start menu → Control panel → Device manager

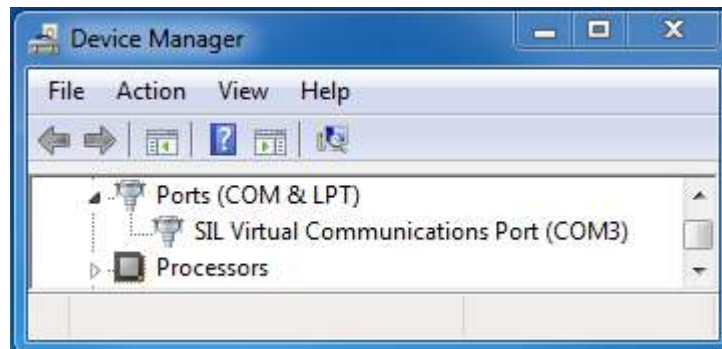

4. Run MB39C031_I2C.exe
5. Click "PORT SEARCH" at "COM PORT SELECT" field and select "SIL Virtual Communications Port (COMxx) "

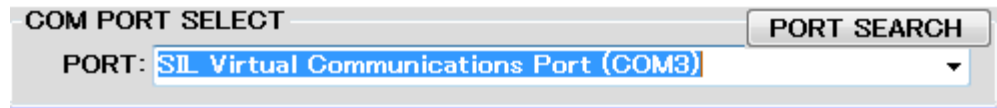

6. Please unplug the USB cable after setup.

4.3.2 Operation check

1. 3.6V is applied to VIN terminal.
2. CTLMAIN switch is turned on.
3. USB cable is connected.
4. Run I²C communication software and click the box of ON/OFF field

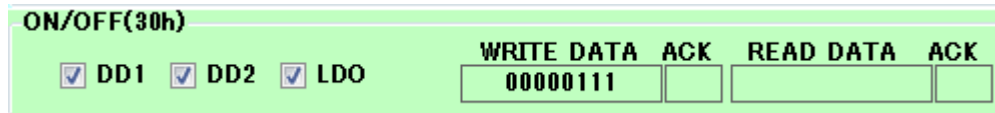

Click the WRITE DATA button.



5. Vo1, Vo2 and LDO are output by software settings

Figure 4-2. For I2C control evaluation

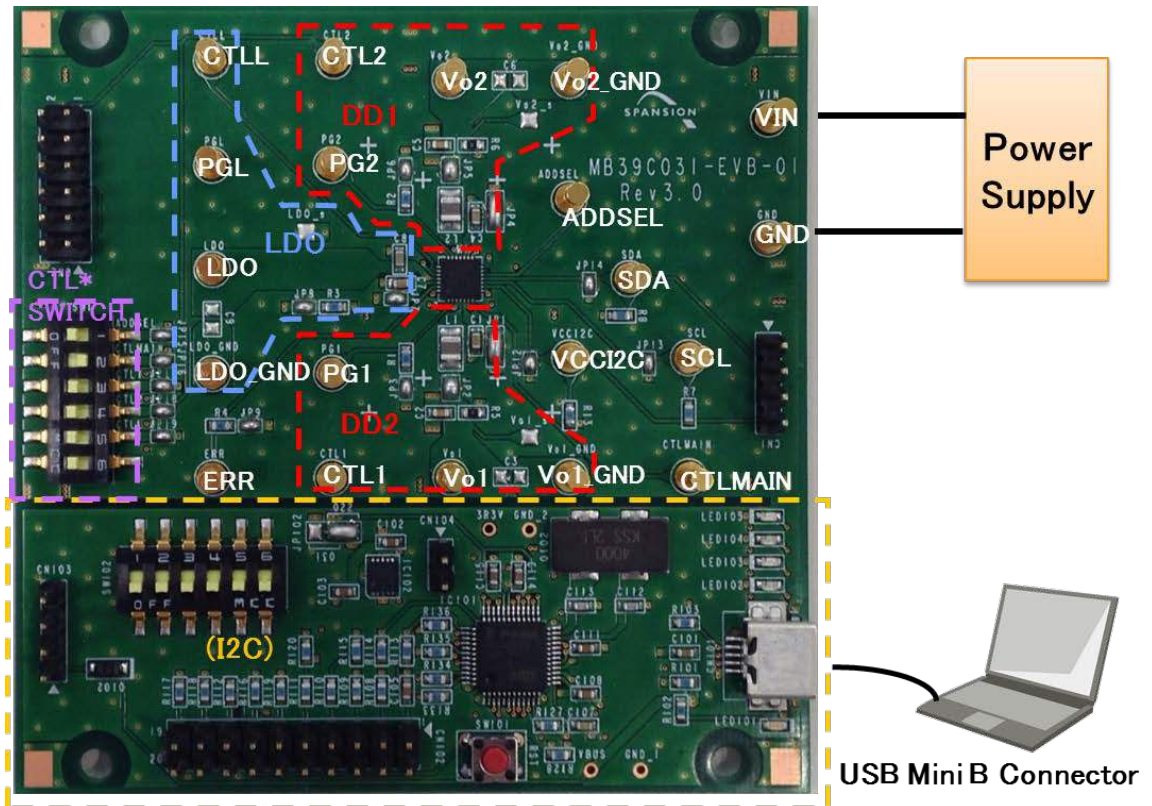

4.3.3 How to use I²C communication GUI

■ Operation at write DATA

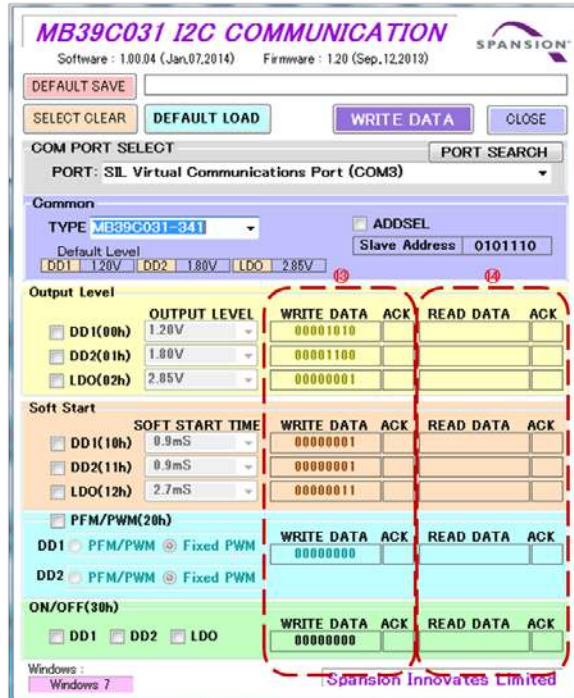

- ⑬ : Data written to IC
 Data is transferred
- ⑭ : Data read from IC
after write
 Data is output

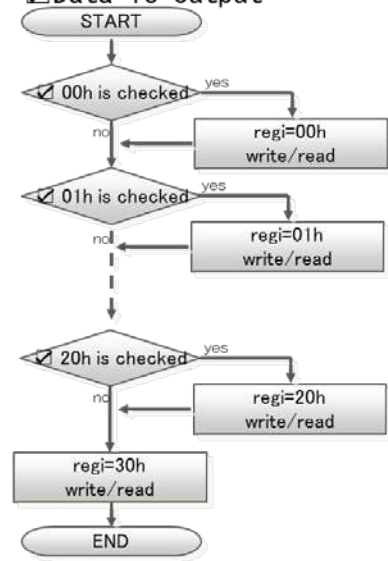

■ Selection of output voltage

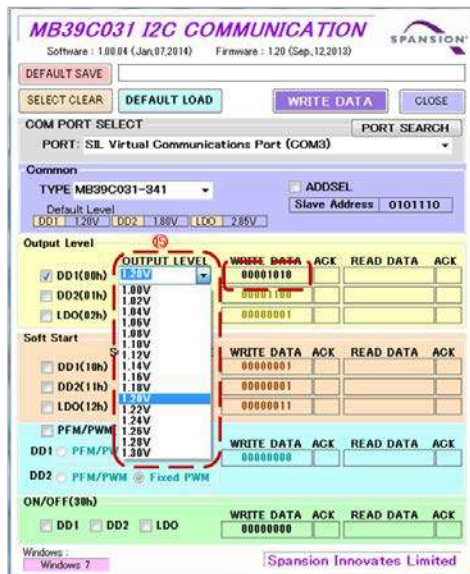

- ⑮ : After checked register address , preset voltage can be selected and bit data is shown.

■ Selection of soft start time

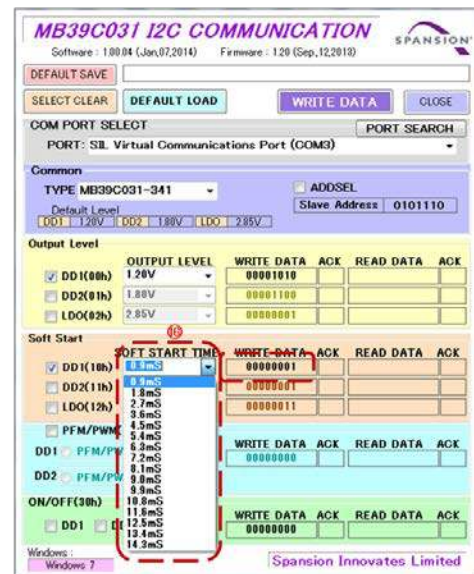

- ⑯ : After checked register address , preset time can be selected and bit data is shown.

4.4 Specification of MB39C031

MB39C031-EVB-01 is preset the following output voltage and soft-start time.

Table 4-1. MB39C031(Option code : 342) Specification

CH	Symbol	Accuracy	Vo (V)			Io(mA)	ILIMIT(mA)	Architecture	FREQUENCY (MHz)	L (uH)	Co (uF)	Soft-Start time (ms)	Discharge R (kΩ)	REMARKS
			MIN	TYP	MAX									
DD1	Vo1	±1.2%	0.99	1.00	1.01	1400	2000	Buck (SYNQ) C-mode	3.0	1.5	10	14.3	5	Internal SWFET Internal Vo setting resistor Operation mode (Fixed PWM, PFM/PWM)
			0.9											
			1.8											
			2.7											
			3.6											
			4.5											
			5.4											
			6.3											
			7.2											
			8.1											
			9.0											
			9.9											
			10.8											
			11.6											
			12.5											
			13.4											
			DD2	Vo2	±1.2%							1.19		
0.9														
1.8														
2.7														
3.6														
4.5														
5.4														
6.3														
7.2														
8.1														
9.0														
9.9														
10.8														
11.6														
12.5														
13.4														
LDO	LDO	±1.8%				2.75	2.80	2.85	(250)	300	LDO	-	-	4.7
			0.9											
			1.8											
			2.7											
			3.6											
			4.5											
			5.4											
			6.3											
			7.2											
			8.1											
			9.0											
			9.9											
			10.8											
			11.6											
			12.5											
			13.4											
						Preset value								

5. Component and Wiring Layout



5.1 Component Layout

Figure 5-1. Component Layout (Layer 1)

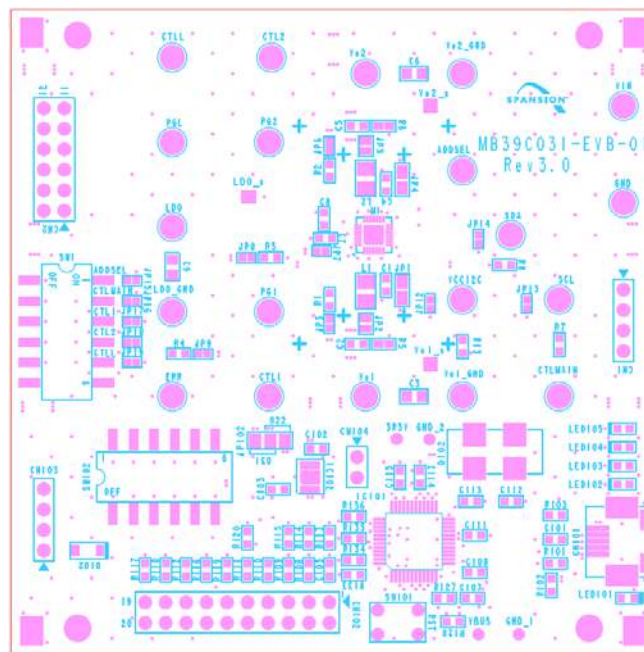
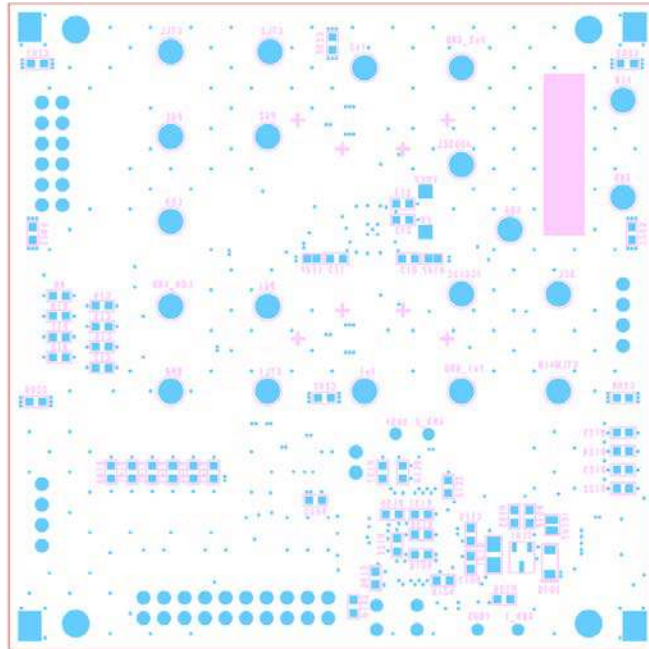

Figure 5-2. Component Layout (Layer 6)



5.2 Wiring layout

Figure 5-3. Wiring layout (layer 1)

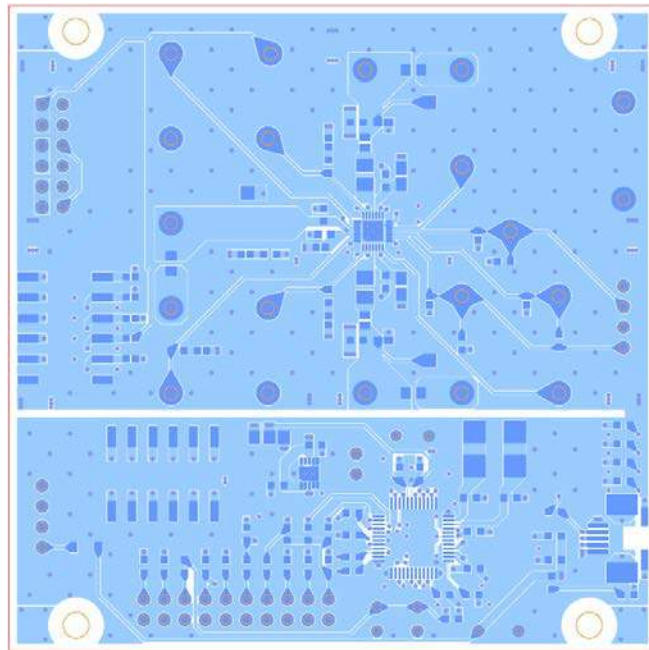

Figure 5-4. Wiring Layout (Layer 2)

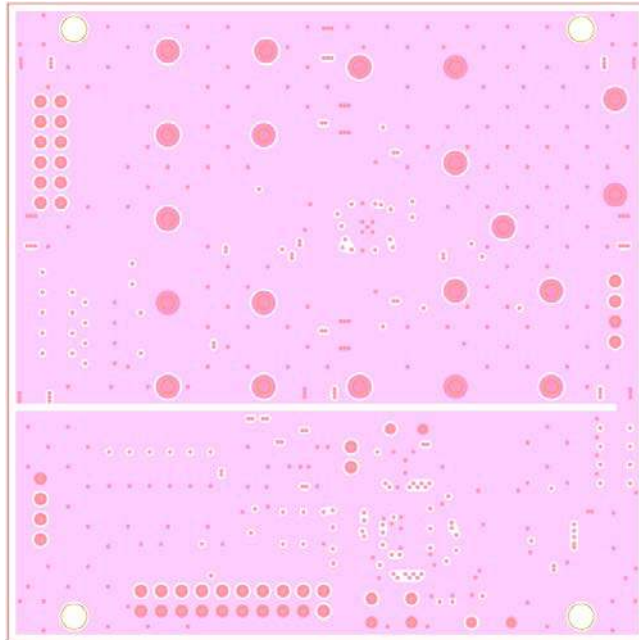

Figure 5-5. Wiring Layout (Layer 3)

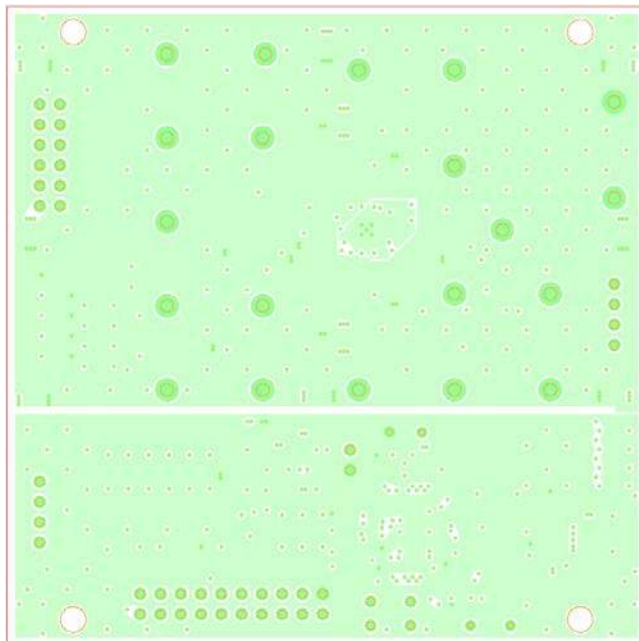

Figure 5-6. Wiring Layout (Layer 4)

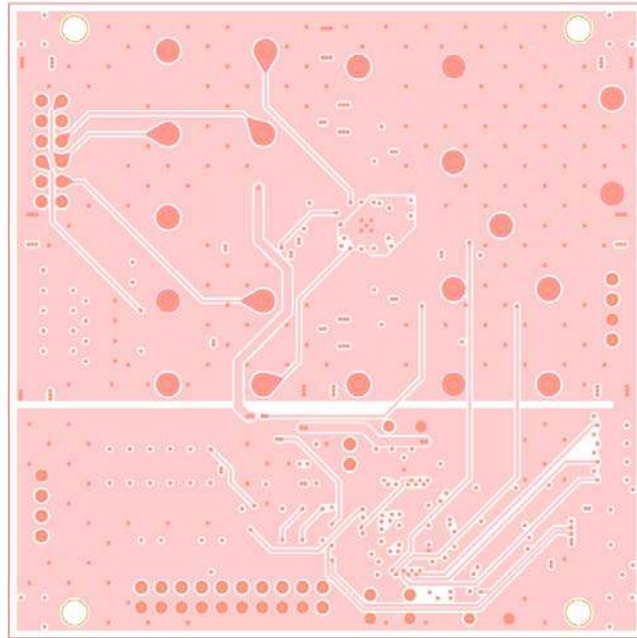

Figure 5-7. Wiring Layout (Layer 5)

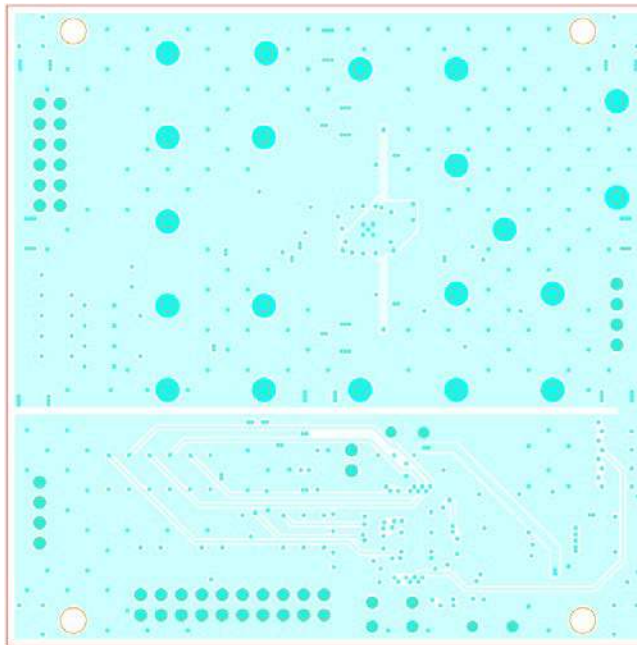
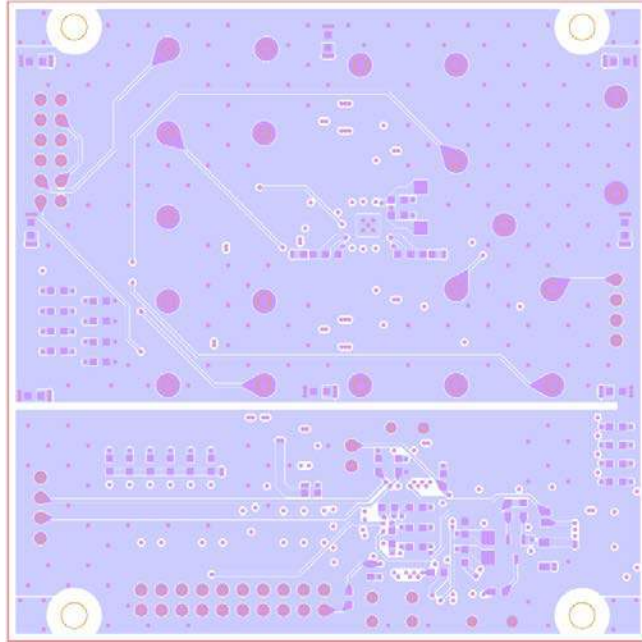

Figure 5-8. Wiring Layout (Layer 6)



6. Circuit Schematic



Figure 6-1. Circuit schematic for power block

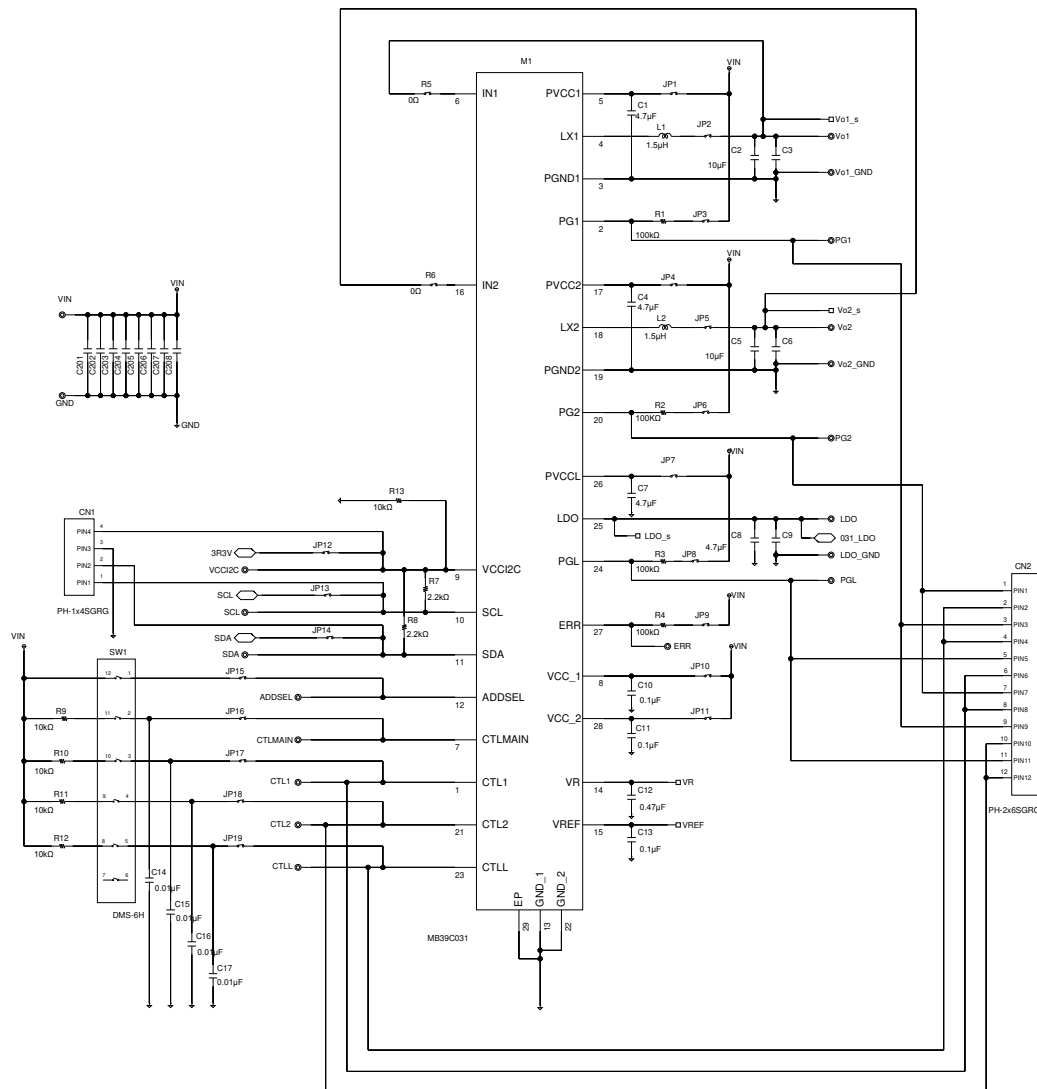
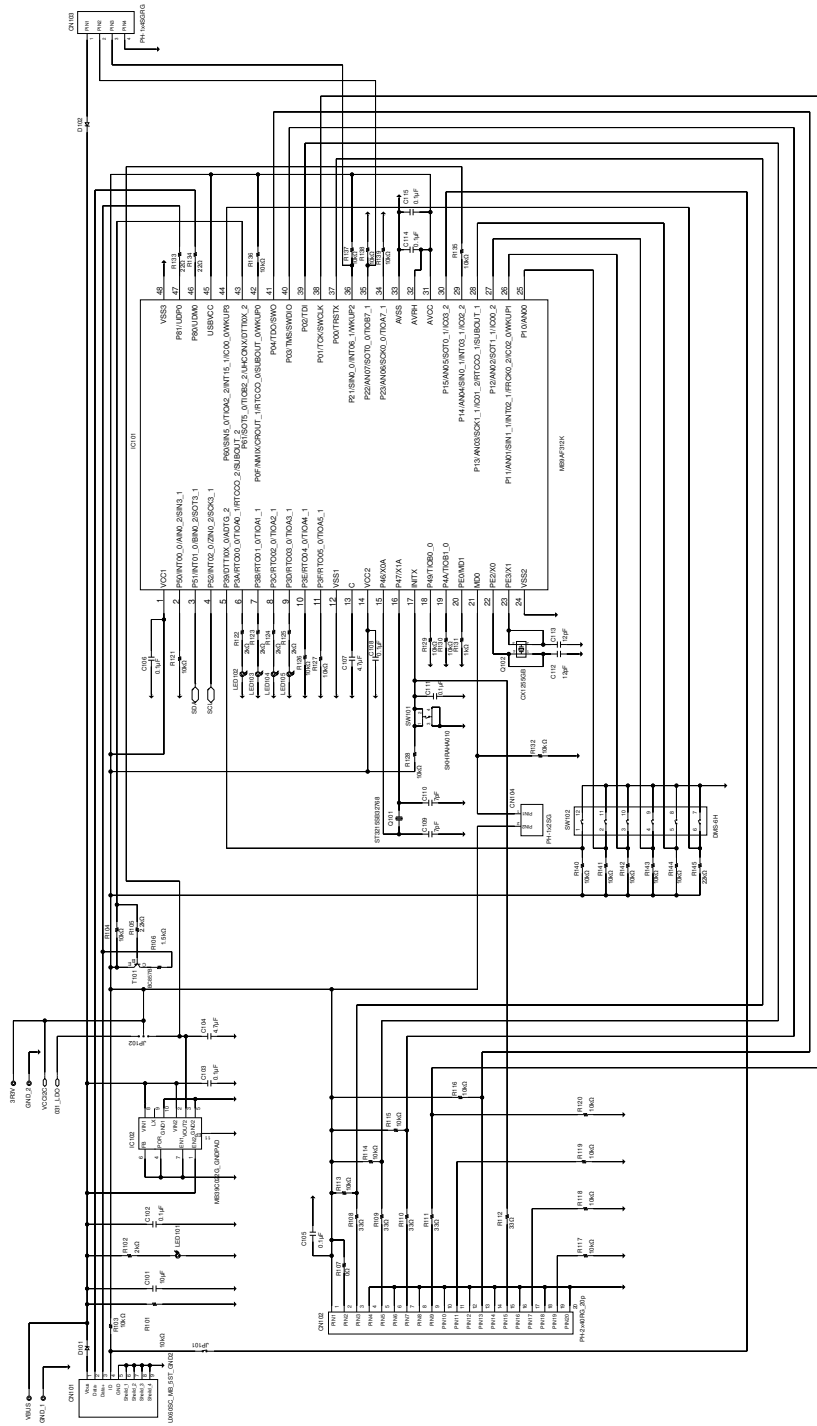

Figure 6-2. Circuit Schematic for MCU Back



7. Component List



Table 7-1. Component list (Power)

No.	Component	Item	Parts number	Vendor	Value	Remarks
1	M1	PMIC	MB39C031	CYPRESS	-	-
2	L1	Inductor	1299AS-H-1R5N=P2	TOKO	1.5μH	-
3	L2	Inductor	1299AS-H-1R5N=P2	TOKO	1.5μH	-
4	C1	Ceramic Capacitor	C1608JB1V475K	TDK	4.7μF	35V
5	C2	Ceramic Capacitor	C1608X5R1E106M	TDK	10μF	25V
6	C3	Ceramic Capacitor	-	-	-	Unmounted
7	C4	Ceramic Capacitor	C1608JB1V475K	TDK	4.7μF	35V
8	C5	Ceramic Capacitor	C1608X5R1E106M	TDK	10μF	25V
9	C6	Ceramic Capacitor	-	-	-	Unmounted
10	C7	Ceramic Capacitor	C1608JB1V475K	TDK	4.7μF	35V
11	C8	Ceramic Capacitor	C1608JB1V475K	TDK	4.7μF	35V
12	C9	Ceramic Capacitor	-	-	-	Unmounted
13	C10	Ceramic Capacitor	C1608JB1H104K	TDK	0.1μF	50V
14	C11	Ceramic Capacitor	C1608JB1H104K	TDK	0.1μF	50V
15	C12	Ceramic Capacitor	C1608JB1H474K	TDK	0.47μF	50V
16	C13	Ceramic Capacitor	C1608JB1H104K	TDK	0.1μF	50V
17	C14	Ceramic Capacitor	C1608JB1H103K	TDK	0.01μF	50V
18	C15	Ceramic Capacitor	C1608JB1H103K	TDK	0.01μF	50V

No.	Component	Item	Parts number	Vendor	Value	Remarks
19	C16	Ceramic Capacitor	C1608JB1H103K	TDK	0.01 μ F	50V
20	C17	Ceramic Capacitor	C1608JB1H103K	TDK	0.01 μ F	50V
21	R1	Chip Resistor	RR0816P104D	SUSUMU	100k Ω	\pm 0.5%, \pm 50ppm
22	R2	Chip Resistor	RR0816P104D	SUSUMU	100k Ω	\pm 0.5%, \pm 50ppm
23	R3	Chip Resistor	RR0816P104D	SUSUMU	100k Ω	\pm 0.5%, \pm 50ppm
24	R4	Chip Resistor	RR0816P104D	SUSUMU	100k Ω	\pm 0.5%, \pm 25ppm
25	R5	Chip Resistor	CR0603-J/-000ELF	BOURNS	0 Ω	1/10W, 5%
26	R6	Chip Resistor	CR0603-J/-000ELF	BOURNS	0 Ω	1/10W, 5%
27	R7	Chip Resistor	RR0816P222D	SUSUMU	2.2k Ω	\pm 0.5%, \pm 25ppm
28	R8	Chip Resistor	RR0816P222D	SUSUMU	2.2k Ω	\pm 0.5%, \pm 25ppm
29	R9	Chip Resistor	RR0816P103D	SUSUMU	10k Ω	\pm 0.5%, \pm 25ppm
30	R10	Chip Resistor	RR0816P103D	SUSUMU	10k Ω	\pm 0.5%, \pm 25ppm
31	R11	Chip Resistor	RR0816P103D	SUSUMU	10k Ω	\pm 0.5%, \pm 25ppm
32	R12	Chip Resistor	RR0816P103D	SUSUMU	10k Ω	\pm 0.5%, \pm 25ppm
33	R13	Chip Resistor	RR0816P103D	SUSUMU	10k Ω	\pm 0.5%, \pm 25ppm
34	JP1	Solder jumper	Solder jumper	-	-	JPPAD_0.8_R2012
35	JP2	Solder jumper	Solder jumper	-	-	JPPAD
36	JP3	Solder jumper	Solder jumper	-	-	JPPAD_0.8
37	JP4	Solder jumper	Solder jumper	-	-	JPPAD_0.8_R2012
38	JP5	Solder jumper	Solder jumper	-	-	JPPAD_0.8
39	JP6	Solder jumper	Solder jumper	-	-	JPPAD_0.8
40	JP7	Solder jumper	Solder jumper	-	-	JPPAD_0.8
41	JP8	Solder jumper	Solder jumper	-	-	JPPAD_0.8
42	JP9	Solder jumper	Solder jumper	-	-	JPPAD_0.8
43	JP10	Solder jumper	Solder jumper	-	-	JPPAD_0.8
44	JP11	Solder jumper	Solder jumper	-	-	JPPAD_0.8
45	JP13	Solder jumper	Solder jumper	-	-	JPPAD_0.8
46	JP14	Solder jumper	Solder jumper	-	-	JPPAD_0.8
47	JP15	Solder jumper	Solder jumper	-	-	JPPAD_0.8
48	JP16	Solder jumper	Solder jumper	-	-	JPPAD_0.8
49	JP17	Solder jumper	Solder jumper	-	-	JPPAD_0.8

No.	Component	Item	Parts number	Vendor	Value	Remarks
50	JP18	Solder jumper	Solder jumper	-	-	JPPAD_0.8
51	JP19	Solder jumper	Solder jumper	-	-	JPPAD_0.8
52	CN101	Connector	PH-1x04SG(RG)	Useconn Electronics Ltd.	4 pin	1x4 pin header(2.54mm pitch), C-03950
53	CN102	Connector	PH-2x06SG(RG)	Useconn Electronics Ltd.	12 pin	2x6 pin header(2.54mm pitch), Divided C-05197
54	SW1	DIP switch	DMS-6H	-	6 pin	-
55	VIN	Terminal	WT-2-1	MAC8	-	-
56	GND	Terminal	WT-2-1	MAC8	-	-
57	VCCI2C	Terminal	WT-2-1	MAC8	-	-
58	SCL	Terminal	WT-2-1	MAC8	-	-
59	SDA	Terminal	WT-2-1	MAC8	-	-
60	ADDSEL	Terminal	WT-2-1	MAC8	-	-
61	CTLMAIN	Terminal	WT-2-1	MAC8	-	-
62	CTL1	Terminal	WT-2-1	MAC8	-	-
63	CTL2	Terminal	WT-2-1	MAC8	-	-
64	CTLL	Terminal	WT-2-1	MAC8	-	-
65	Vo1	Terminal	WT-2-1	MAC8	-	-
66	Vo1_GND	Terminal	WT-2-1	MAC8	-	-
67	PG1	Terminal	WT-2-1	MAC8	-	-
68	Vo2	Terminal	WT-2-1	MAC8	-	-
69	Vo2_GND	Terminal	WT-2-1	MAC8	-	-
70	PG2	Terminal	WT-2-1	MAC8	-	-
71	LDO	Terminal	WT-2-1	MAC8	-	-
72	LDO_GND	Terminal	WT-2-1	MAC8	-	-
73	PGL	Terminal	WT-2-1	MAC8	-	-
74	ERR	Terminal	WT-2-1	MAC8	-	-
75	C201	Capacitor	-	-	-	Unmounted
76	C202	Capacitor	-	-	-	Unmounted
77	C203	Capacitor	-	-	-	Unmounted
78	C204	Capacitor	-	-	-	Unmounted
79	C205	Capacitor	-	-	-	Unmounted
80	C206	Capacitor	-	-	-	Unmounted
81	C207	Capacitor	-	-	-	Unmounted
82	C208	Capacitor	-	-	-	Unmounted

These components are compliant with RoHS, and please ask each vendor for details if necessary.

Table 7-2. Component List (MCU)

No.	Component	Item	Parts number	Vendor	Value	Remark
1	IC101	MCU	MB9AF312K	CYPRESS	-	-
2	IC102	PMIC	MB39C022G	CYPRESS	-	-
3	R101	Resistor	RR0816P103D	SUSUMU	10kΩ	1/16W, 0.5%
4	R102	Resistor	RR0816P202D	SUSUMU	2kΩ	1/16W, 0.5%
5	R103	Resistor	RR0816P103D	SUSUMU	10kΩ	1/16W, 0.5%
6	R104	Resistor	RR0816P103D	SUSUMU	10kΩ	1/16W, 0.5%
7	R105	Resistor	RR0816P222D	SUSUMU	2.2kΩ	1/16W, 0.5%
8	R106	Resistor	RR0816P152D	SUSUMU	1.5kΩ	1/16W, 0.5%
9	R107	Resistor	CR0603-J/-000ELF	BOURNS	0Ω	1/10W, 5%
10	R108	Resistor	RR0816Q330D	SUSUMU	33Ω	1/16W, 0.5%
11	R109	Resistor	RR0816Q330D	SUSUMU	33Ω	1/16W, 0.5%
12	R110	Resistor	RR0816Q330D	SUSUMU	33Ω	1/16W, 0.5%
13	R111	Resistor	RR0816Q330D	SUSUMU	33Ω	1/16W, 0.5%
14	R112	Resistor	RR0816Q330D	SUSUMU	33Ω	1/16W, 0.5%
15	R113	Resistor	RR0816P103D	SUSUMU	10kΩ	1/16W, 0.5%
16	R114	Resistor	RR0816P103D	SUSUMU	10kΩ	1/16W, 0.5%
17	R115	Resistor	RR0816P103D	SUSUMU	10kΩ	1/16W, 0.5%
18	R116	Resistor	RR0816P103D	SUSUMU	10kΩ	1/16W, 0.5%
19	R117	Resistor	RR0816P103D	SUSUMU	10kΩ	1/16W, 0.5%
20	R118	Resistor	RR0816P103D	SUSUMU	10kΩ	1/16W, 0.5%
21	R119	Resistor	RR0816P103D	SUSUMU	10kΩ	1/16W, 0.5%
22	R120	Resistor	RR0816P103D	SUSUMU	10kΩ	1/16W, 0.5%
23	R121	Resistor	RR0816P103D	SUSUMU	10kΩ	1/16W, 0.5%
24	R122	Resistor	RR0816P202D	SUSUMU	2kΩ	1/16W, 0.5%
25	R123	Resistor	RR0816P202D	SUSUMU	2kΩ	1/16W, 0.5%
26	R124	Resistor	RR0816P202D	SUSUMU	2kΩ	1/16W, 0.5%
27	R125	Resistor	RR0816P202D	SUSUMU	2kΩ	1/16W, 0.5%
28	R126	Resistor	RR0816P103D	SUSUMU	10kΩ	1/16W, 0.5%
29	R127	Resistor	RR0816P103D	SUSUMU	10kΩ	1/16W, 0.5%
30	R128	Resistor	RR0816P103D	SUSUMU	10kΩ	1/16W, 0.5%
31	R129	Resistor	RR0816P103D	SUSUMU	10kΩ	1/16W, 0.5%
32	R130	Resistor	RR0816P103D	SUSUMU	10kΩ	1/16W, 0.5%
33	R131	Resistor	RR0816P102D	SUSUMU	1kΩ	1/16W, 0.5%
34	R132	Resistor	RR0816P103D	SUSUMU	10kΩ	1/16W, 0.5%
35	R133	Resistor	RR0816Q220D	SUSUMU	22Ω	1/16W, 0.5%
36	R134	Resistor	RR0816Q220D	SUSUMU	22Ω	1/16W, 0.5%
37	R135	Resistor	RR0816P103D	SUSUMU	10kΩ	1/16W, 0.5%
38	R136	Resistor	RR0816P103D	SUSUMU	10kΩ	1/16W, 0.5%
39	R137	Resistor	RR0816P103D	SUSUMU	10kΩ	1/16W, 0.5%
40	R138	Resistor	RR0816P103D	SUSUMU	10kΩ	1/16W, 0.5%
41	R139	Resistor	RR0816P103D	SUSUMU	10kΩ	1/16W, 0.5%

No.	Component	Item	Parts number	Vendor	Value	Remark
42	R140	Resistor	RR0816P103D	SUSUMU	10kΩ	1/16W, 0.5%
43	R141	Resistor	RR0816P103D	SUSUMU	10kΩ	1/16W, 0.5%
44	R142	Resistor	RR0816P103D	SUSUMU	10kΩ	1/16W, 0.5%
45	R143	Resistor	RR0816P103D	SUSUMU	10kΩ	1/16W, 0.5%
46	R144	Resistor	RR0816P103D	SUSUMU	10kΩ	1/16W, 0.5%
47	R145	Resistor	RR0816P103D	SUSUMU	10kΩ	1/16W, 0.5%
48	C101	Capacitor	C1608JB1H106M	TDK	10μF	50V
49	C102	Capacitor	C1608JB1H104K	TDK	0.1μF	50V
50	C103	Capacitor	C1608JB1H104K	TDK	0.1μF	50V
51	C104	Capacitor	C1608JB1V475K	TDK	4.7μF	35V
52	C105	Capacitor	C1608JB1H104K	TDK	0.1μF	50V
53	C106	Capacitor	C1608JB1H104K	TDK	0.1μF	50V
54	C107	Capacitor	C1608JB1V475K	TDK	4.7μF	35V
55	C108	Capacitor	C1608JB1H104K	TDK	0.1μF	50V
56	C109	Capacitor	C1608CH1H070D080 AA	TDK	7pF	50V
57	C110	Capacitor	C1608CH1H070D080 AA	TDK	7pF	50V
58	C111	Capacitor	C1608JB1H104K	TDK	0.1μF	50V
59	C112	Capacitor	C1608C0G1H120J080 AA	TDK	12pF	50V
60	C113	Capacitor	C1608C0G1H120J080 AA	TDK	12pF	50V
61	C114	Capacitor	C1608JB1H104K	TDK	0.1μF	50V
62	C115	Capacitor	C1608JB1H104K	TDK	0.1μF	50V
63	CN101	Connector	UX60SC-MB-5ST	Hirose Electric	-	mini USB
64	CN102	Connector	PH-2xXXRG	Useconn Electronics Ltd.	-	2x10 pin header, Divided C-05197
65	CN103	Connector	PH-1xXXRG	Useconn Electronics Ltd.	-	1x4 pin header, C- 03950
66	CN104	Connector	PH-1xXXRG	Useconn Electronics Ltd.	-	1x2 pin header, Divided C-00167
67	D101	Diode	RB161M-20TR	ROHM	-	-
68	D102	Diode	RB161M-20TR	ROHM	-	-
69	LED101	LED	OSHR1608C1A	OptoSupply	-	RED
70	LED102	LED	OSTG1608C1A	OptoSupply	-	GREEN
71	LED103	LED	OSTG1608C1A	OptoSupply	-	GREEN
72	LED104	LED	OSTG1608C1A	OptoSupply	-	GREEN
73	LED105	LED	OSTG1608C1A	OptoSupply	-	GREEN
74	JP101	Solder jumper	JPPAD	-	-	Unmounted
75	JP102	Solder jumper	JPPAD	-	-	3pin, 3216 Shorted to 022

No.	Component	Item	Parts number	Vendor	Value	Remark
76	SW101	Push-SW	SKHRAHA010	ALPS Electric	-	-
77	SW102	DIPSW	DMS-6H	-	-	6pin,2.54mm pitch
78	Q101	Crystal	-	-	-	Unmounted
79	Q102	Crystal	CX1255GB04000H0P ESZ1	KYOCERA	4MHz	-
80	T101	Transistor	BC857BLT1G	ROHM	-	PNP
81	VBUS	Monitor pin	-	-	-	Unmounted
82	GND_1	Monitor pin	-	-	-	Unmounted
83	3R3V	Monitor pin	-	-	-	Unmounted
84	GND_2	Monitor pin	-	-	-	Unmounted

These components are compliant with RoHS, and please ask each vendor for details if necessary.

TOKO : TOKO, INC.
 TDK : TDK Corporation
 SUSUMU : SUSUMU Co., Ltd.
 MAC8 : Mac-Eight Co., Ltd.
 BOURNS : Bourns, Inc.
 Hirose Electric : HIROSE Electric Co., Ltd.
 ROHM : ROHM Co., Ltd.
 OptoSupply : Opto Supply Limited
 KYOCERA : KYOCERA Corporation
 ALPS Electric : ALPS ELECTRIC CO., LTD.

8. Evaluation Board Picture



Figure 8-1. Picture (top)

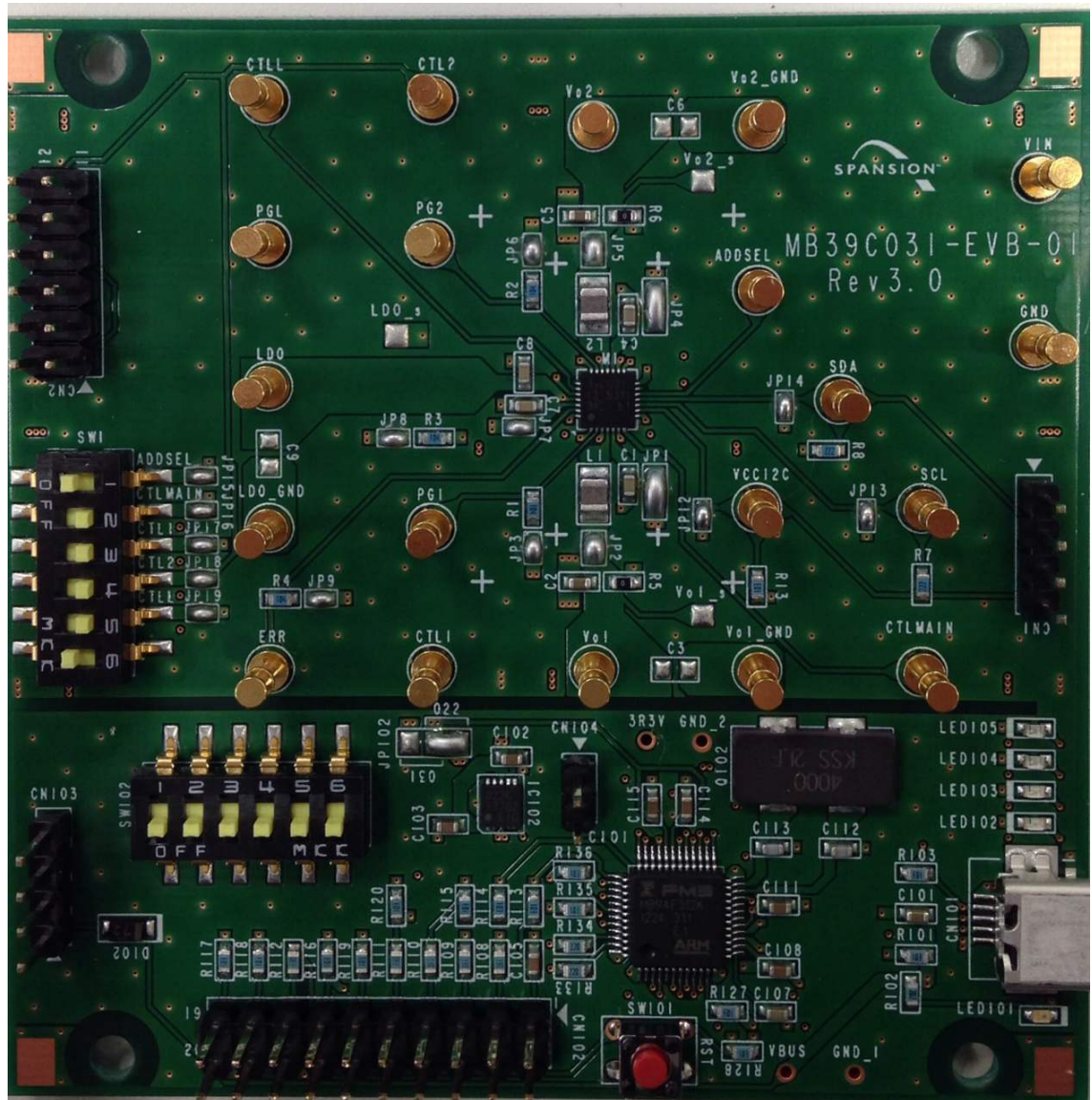
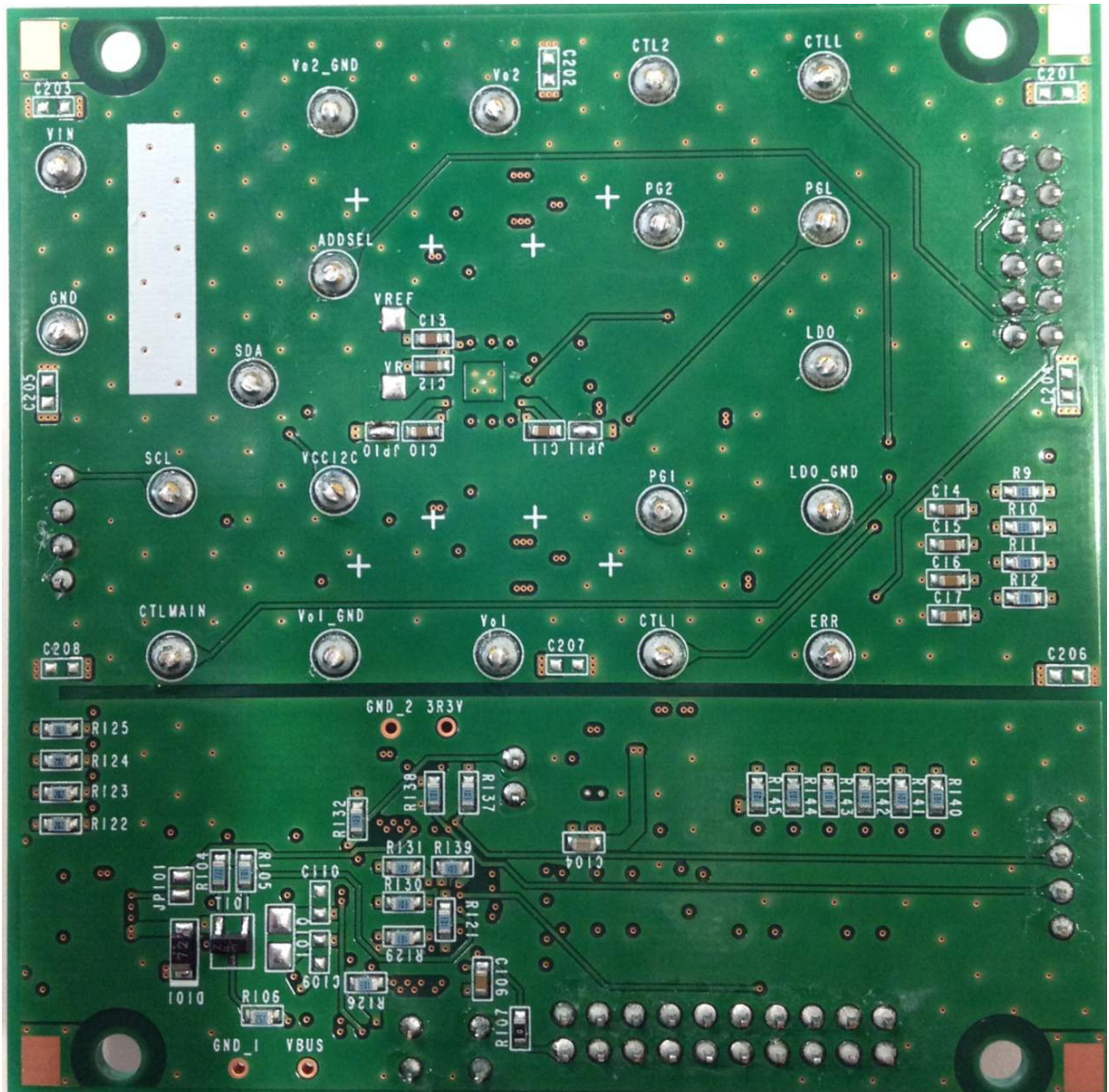

Figure 8-2. Picture (back)



9. Ordering Information



Table 9-1. Ordering Information

Part number	EVB revision	Note
MB39C031-EVB-01	Rev 3.0	---

Revision History



Document Revision History

Document Title: MB39C031-EVB-01 2ch Buck DC/DC + LDO with I ² C Interface Evaluation Board Operation Guide				
Document Number: 002-08673				
Revision	ECN	Origin of Change	Issue Date	Description of Change
**	-	ATTS	02/28/2014	Initial release
*A	5120318	ATTS	02/04/2016	Migrated Spansion Guide from MB39C031-EVB-01_SS901-00021-1v0-E to Cypress format
*B	5959783	MASG	11/07/2017	Adapted Cypress new logo.
*C	6069442	YOST	02/13/2018	Updated the Sales information and legal. Completing Sunset Review.