

LTC3113EDHD

3A Low Noise Buck-Boost DC/DC Converter

DESCRIPTION

Demonstration Circuit 1551A is a wide V_{in} range, highly efficient, fixed frequency buck-boost converter. The unique 4-switch, single inductor architecture provides low noise and seamless operation from input voltages above, below, or equal to the output voltage.

The LTC3113 features selectable PWM or Burst Mode operation and an oscillator with a programmable frequency from 300kHz to 2MHz. The LTC3113 can deliver up to 3A of continuous output current to satisfy most demanding applications. Higher output currents are possible in step-down (buck) mode.

The LTC3113 operates with a 1.8V to 5.5V input and output voltage range. The demonstration board has

been designed to operate over the full input voltage range, with V_{OUT} set to 3.3V and I_{OUT} of 3.0A. For $V_{IN} < 3V$, I_{OUT} capability is reduced. Typical demo board efficiency is shown below.

Design files for this circuit board are available. Call the LTC factory.

LTC, LTC, LTM, LT, Burst Mode, are registered trademarks of Linear Technology Corporation. All other trademarks are the property of their respective owners.

Input Voltage Range: V_{CC}	1.8V to 5.5V
V_{OUT}	3.3V
I_{OUT}	3.0A for $V_{IN} > 3.0V$

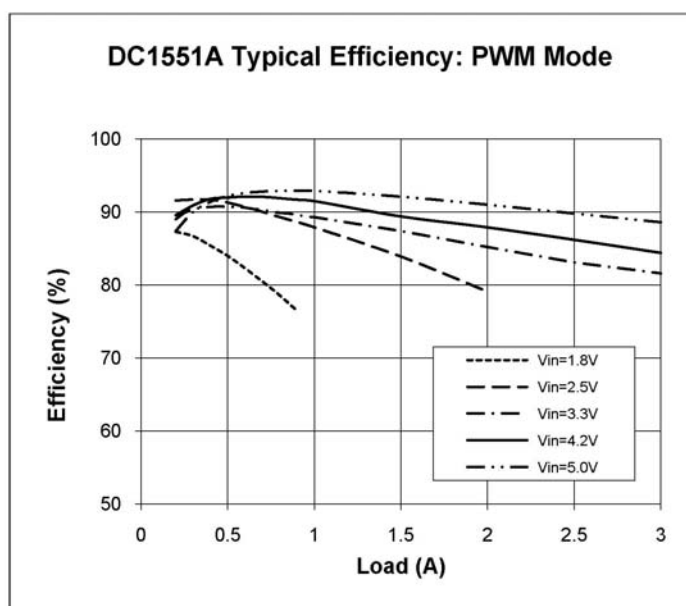

Figure 1. Typical Efficiency

QUICK START PROCEDURE

Using short twisted pair leads for any power connections and with all loads and power supplies off, refer to Figure 2 for the proper measurement and equipment setup. The Battery/Power Supply (PS1) should not be connected to the circuit until told to do so in the procedure below.

When measuring the input or output voltage ripple, care must be taken to avoid a long ground lead on the oscilloscope probe.

1. Jumper, PS1 and LOAD Settings to start:
PS1= OFF
JP1 (PWM) = FIXED FREQ
JP2 = OFF
LOAD = 1.0A / 3.32 Ω 10W resistor
2. With power OFF connect the power supply (PS1) as shown in Figure 2. If accurate current measurements are desired (for efficiency calculations for example) then connect an ammeter in series with the supply as shown. The ammeter is not required however.
3. Connect the load to VOUT as shown in Figure 2. Again, connect an ammeter if accurate current measurement or monitoring is desired.
4. Turn on PS1 and slowly increase voltage until the voltage at VIN is 3.0V. Move Jumper JP2 to ON.
5. Verify VOUT is ~3.3V.
6. VIN can now be varied between 1.8V and 5.5V. VOUT should remain in regulation.
7. IOUT can also be varied from 0 to 3.0A. For VIN < 3.0V, maximum IOUT is reduced. This reduction is due to I_{in} increasing as VIN decreases. Once the input current limit is reached, VOUT will drop out of regulation.
NOTE: If VOUT drops out of regulation, check to be sure the maximum load has not been exceeded, or that VIN is not below the minimum value (1.8V).
8. For operation in BURST Mode move Jumper JP1 to BURST. IOUT is limited in BURST MODE. See the datasheet for more information.
NOTE: For applications with large output current steps, such as GSM applications, additional output capacitance can be added to the demo board. The capacitor footprints at C4 and C10 are provided for additional output capacitors.

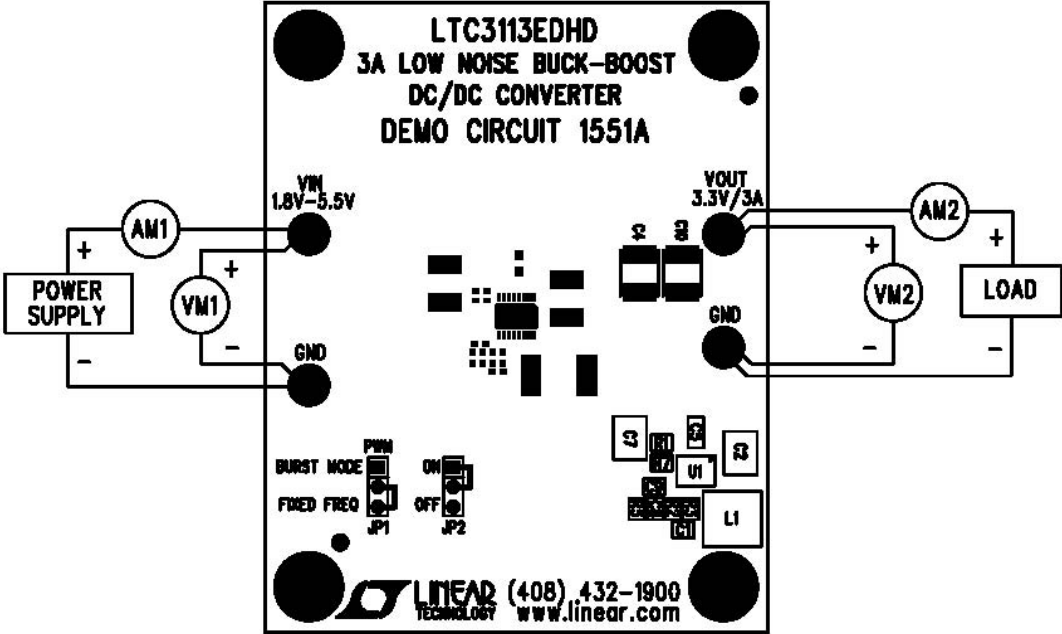

Figure 2. Measurement Setup

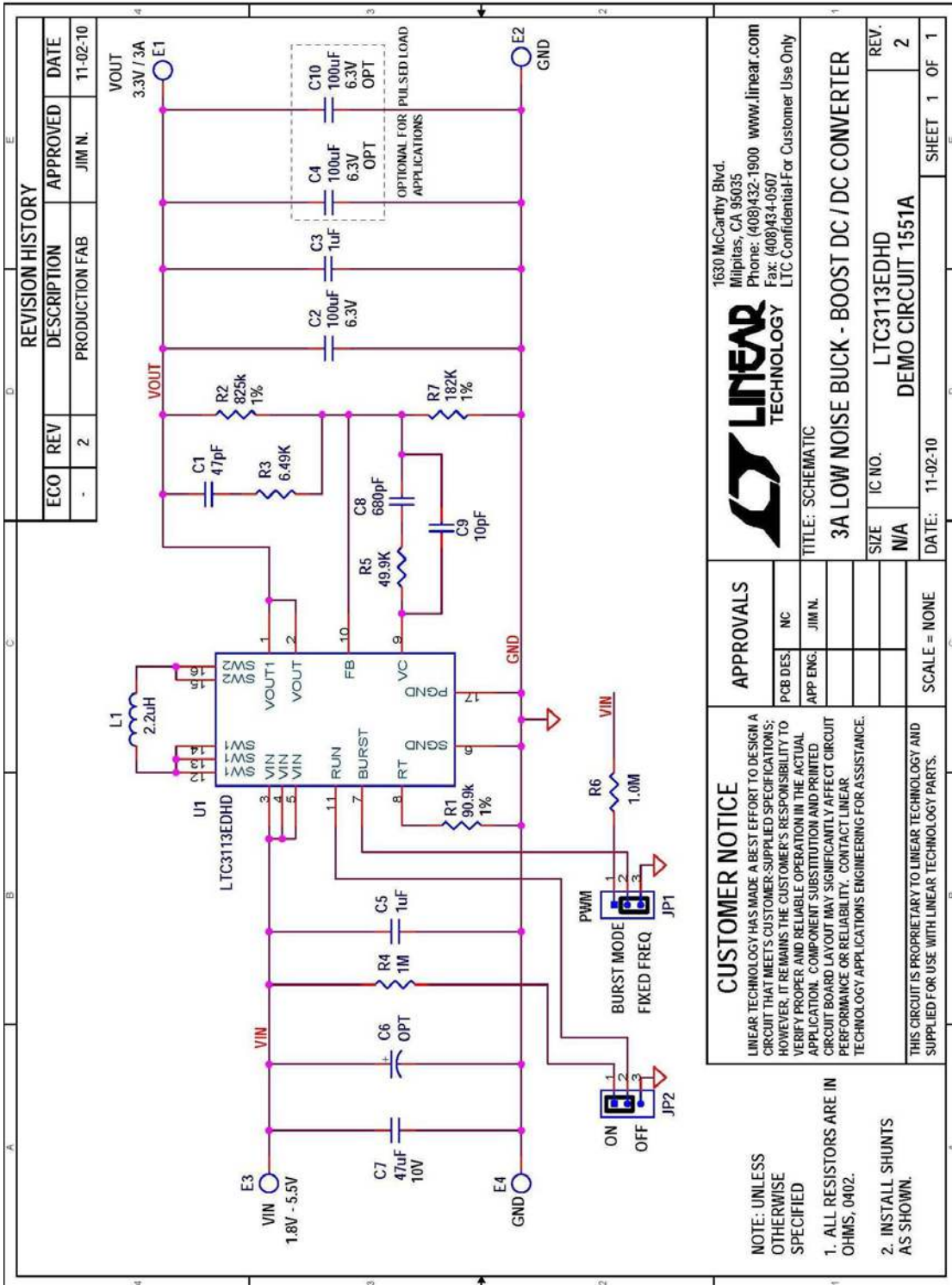

Figure 3. Circuit Schematic

Item	Qty	Reference	Part Description	Manufacturer / Part #
REQUIRED CIRCUIT COMPONENTS:				
1	1	C1	CAP CER 47PF 50V C0G 5% 0402	TDK, C1005C0G1H470J
2	1	C2	CAP CER 100UF 6.3V X5R 20% 1812	TDK, C4532X5R0J107M
3	2	C3,C5	CAP CER 1.0UF 10V X5R 10% 0603	TDK, C1608X5R1A105K
4	1	C7	CAP CER 47UF 10V X5R 20% 1812	TDK, C4532X5R1A476M
5	1	C8	CAP CER 680PF 25V C0G 5% 0402	TDK, C1005C0G1E681J
6	1	C9	CAP CER 10PF 50V C0G 0402 ±0.5pF	TDK, C1005C0G1H100D
7	1	L1	INDUCTOR, 2.2uH, 8A	MAG.LAYERS, MMD-06CZ-2R2M-V1-LT
8	1	R1	RES 90.9K OHM 1/10W 1% 0402 SMD	PANASONIC, ERJ-2RKF9092X
9	1	R2	RES 825K OHM 1/10W 1% 0402 SMD	PANASONIC, ERJ-2RKF8253X
10	1	R3	RES 6.49K OHM 1/10W 1% 0402 SMD	PANASONIC, ERJ-2RKF6491X
11	2	R4, R6	RES, 1.00M OHM 1/16W 1% 0402 SMD	PANASONIC, ERJ-2RKF1004X
12	1	R5	RES 49.9K OHM 1/10W 1% 0402 SMD	PANASONIC, ERJ-2RKF4992X
13	1	R7	RES 182K OHM 1/10W 1% 0402 SMD	PANASONIC, ERJ-2RKF1823X
14	1	U1	3A LOW NOISE BUCK-BOOST DC/DC CONVERTER	LINEAR TECH., LTC3113EDHD#PBF
ADDITIONAL DEMO BOARD CIRCUIT COMPONENTS:				
1	0	C4, C10, (OPT)	CAP 100uF 6.3V X5R 20% 1812	
2	0	C6, (OPT)	CAP TANT LOW ESR 47UF 35V 20% SMD	AVX, TPSD476K035R0200
HARDWARE-FOR DEMO BOARD ONLY:				
1	4	E1-E4	TP, TURRET, 0.094", PBF	MILL-MAX, 2501-2-00-80-00-00-07-0
2	2	JP1,JP2	JMP, 3PIN 1 ROW .079CC	SAMTEC, TMM-103-02-L-S
3	2	SHUNT JP1 (2&3), JP2 (1&2)	SHUNT, .079" CENTER	SAMTEC, 2SN-BK-G
4	4	STAND OFF	STAND-OFF, NYLON 0.375" TALL	KEYSTONE, 8832 (SNAP ON)

Figure 4. Bill of Materials