

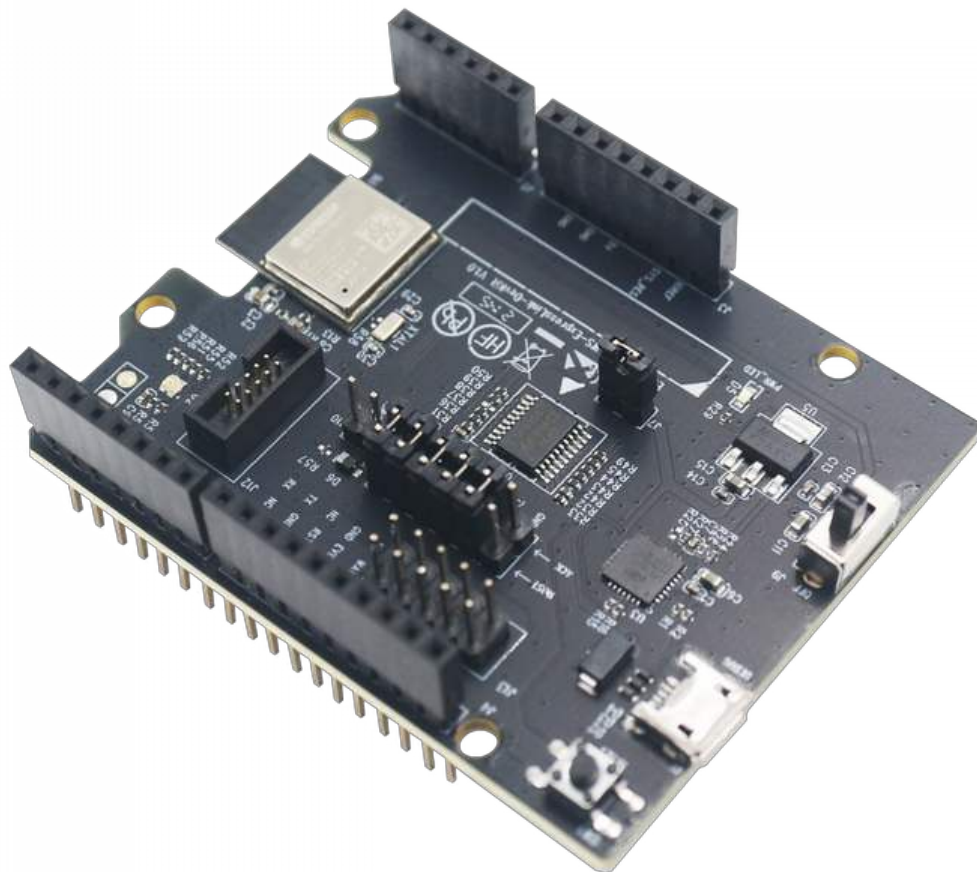

ESP32-C3-AWS-ExpressLink-DevKit

[\[中文\]](#)

This user guide will help you get started with ESP32-C3-AWS-ExpressLink-DevKit and will also provide more in-depth information.



ESP32-C3-AWS-ExpressLink-DevKit with ESP32-C3-MINI-1-N4-A module

ESP32-C3-AWS-ExpressLink-DevKit is a development board based on the ESP32-C3-MINI-1-N4-A module. Its pin layout is compatible with that of the Arduino Zero development board, and therefore ESP32-C3-AWS-ExpressLink-DevKit can be directly plugged in Arduino Zero, or connected with other host boards and peripherals via jumpers.

The document consists of the following major sections:

- [Getting Started](#): Overview of the board and hardware/software setup instructions to get started.

- [Hardware Reference](#): More detailed information about the board's hardware.
- [Hardware Revision Details](#): Hardware revision history, known issues, and links to user guides for previous versions (if any) of the board.
- [Related Documents](#): Links to related documentation.

Getting Started

This section provides a brief introduction of ESP32-C3-AWS-ExpressLink-DevKit, instructions on how to do the initial hardware setup and how to flash firmware onto it.

Description of Components

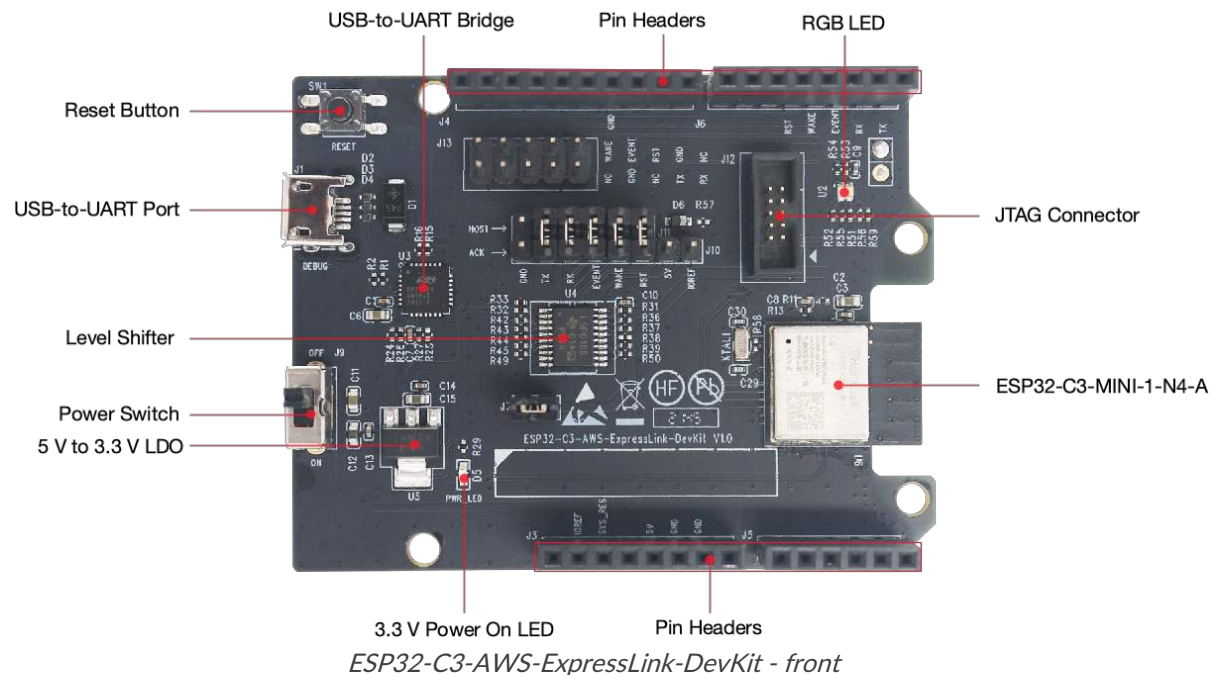

The key components of the board are described in a clockwise direction.

Key Component	Description
ESP32-C3-MINI-1-N4-A	ESP32-C3-MINI-1 is a general-purpose Wi-Fi and Bluetooth LE combo module that comes with a PCB antenna. At the core of this module is ESP32-C3FN4, a chip that has an embedded flash of 4 MB. ESP32-C3-AWS-ExpressLink-DevKit uses ESP32-C3-MINI-1-N4-A, a variant of ESP32-C3-MINI-1 delivered pre-programmed with a customized firmware.
Pin Headers	The AWS interface is broken out to pin headers, so that it becomes easier to connect any host applications to AWS IoT Core and its services.
3.3 V Power On LED	Turns on when the board is powered on, and the Power Switch is ON.
5 V to 3.3 V LDO	Power regulator that converts a 5 V DC supply into a 3.3 V output.
Power Switch	Powers the board on and off.
Level Shifter	Translates I/O levels from 1.8 V to 5 V according to the level of IOREF, a pin on Arduino Zero board.

Key Component	Description
USB-to-UART Port	Micro USB interface. Power supply for the board as well as the communication interface with other USB devices.
Reset Button	Press this button to restart the AWS module.
USB-to-UART Bridge	Single USB-UART bridge chip provides transfer rates up to 3 Mbps.
RGB LED	Addressable RGB LED (EAST1616RGBA3), driven by three GPIOs.
JTAG Connector	A JTAG connector compatible with Espressif's debugging board ESP-PROG. The JTAG debugging interface of ESP32-C3-MINI-1-N4-A is broken out to this connector.

Start Application Development

Before powering up your board, please make sure that it is in good condition with no obvious signs of damage.

Required Hardware

- ESP32-C3-AWS-ExpressLink-DevKit
- USB 2.0 cable (Standard-A to Micro-B)
- Computer running Windows, Linux, or macOS

Note

Be sure to use an appropriate USB cable. Some cables are for charging only and do not provide the needed data lines nor work for programming the boards.

Hardware Setup

Connect the board with the computer using **USB-to-UART Port**.

Software Setup

This development board has been flashed with the default firmware. For more development resources and instructions, please check [ESP-AWS-ExpressLink-Eval repository](#).

Contents and Packaging

Retail Orders

If you order a few samples, each board comes in an individual package in either antistatic bag or any packaging depending on your retailer.

For retail orders, please go to <https://www.espressif.com/en/company/contact/buy-a-sample>.

Wholesale Orders

If you order in bulk, the boards come in large cardboard boxes.

For wholesale orders, please go to <https://www.espressif.com/en/contact-us/sales-questions>.

Hardware Reference

Block Diagram

The block diagram below shows the components of ESP32-C3-AWS-ExpressLink-DevKit and their interconnections.

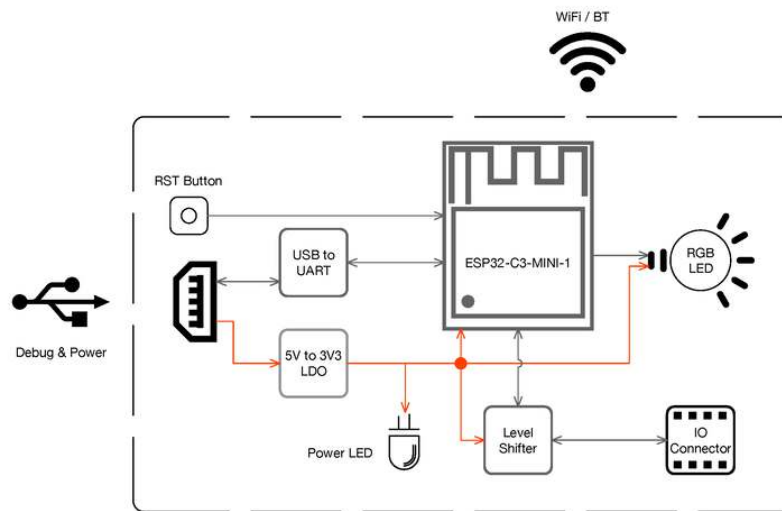

ESP32-C3-AWS-ExpressLink-DevKit (click to enlarge)

Power Supply Options

There are four mutually exclusive ways to provide power to the board:

- USB-to-UART Port, default power supply
- 5V and G (GND) pins
- 3V3 and G (GND) pins
- Host board when ESP32-C3-AWS-ExpressLink-DevKit works with one

Hardware Revision Details

This is the first revision of this board released.

Related Documents

- [ESP32-C3 Series Datasheet \(PDF\)](#)
- [ESP32-C3-MINI-1 & ESP32-C3-MINI-1U Datasheet \(PDF\)](#)
- [ESP32-C3-AWS-ExpressLink-DevKit Schematic \(PDF\)](#)

For further design documentation for the board, please contact us at sales@espressif.com.

[Provide feedback about this document](#)

[← Previous](#)

[Next →](#)

© Copyright 2016 - 2021, Espressif Systems (Shanghai) Co., Ltd

Built with [Sphinx](#) using a [theme](#) based on [Read the Docs Sphinx Theme](#).

[Download PDF](#)