

NOTES:

1. MATERIALS AND FINISHES:
 FAKRA SMB PLUG: BODY - ZINC ALLOY, NICKEL PLATING
 CENTER CONTACT - BERYLLIUM COPPER, GOLD PLATING
 AMC PLUG: BODY - PHOSPHOR BRONZE, GOLD PLATING
 CENTER CONTACT - PHOSPHOR BRONZE, GOLD PLATING
 CABLE: 1.37MM MICRO-COAX
2. ELECTRICAL :
 A. IMPEDANCE: 50 OHM
3. MECHANICAL:
 A. RECOMMENDED LOCKWASHER TORQUE: 1.13 N-M [10 IN-LBS]
4. PACKAGING:
 A. QUANTITY: SINGLE PACK
 B. MARKING: BAG TO BE MARKED
 "AMPHENOL RF, 95-820-109-XXX, AND DATE CODE"

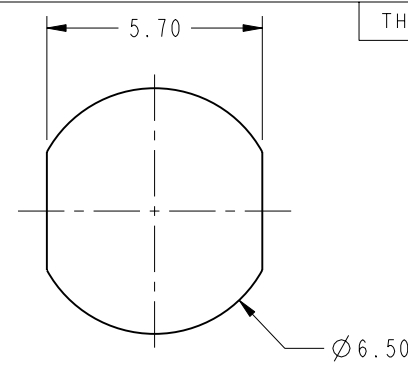

RECOMMENDED MOUNTING HOLE DIMENSIONS

THIRD ANGLE PROJ.

REVISIONS				
REV	DESCRIPTION	DATE	ECN	APPR
A	RELEASE TO MFG.	12-Feb-18	06921	BMG
B	FAKRA KEY TABLE ADDED	23-Aug-18	08941	KR
C	PLAING SPEC. FOR AMC PLUG BODY WAS SILVER, AMC CONNECTOR WAS CHANGED	01-Mar-19	10721	JC
D	ADDED THE 95-820-109-20E ADDED AMC CONNECTOR DIRECTION REQUIREMENT	24-Jun-19	11943	SH

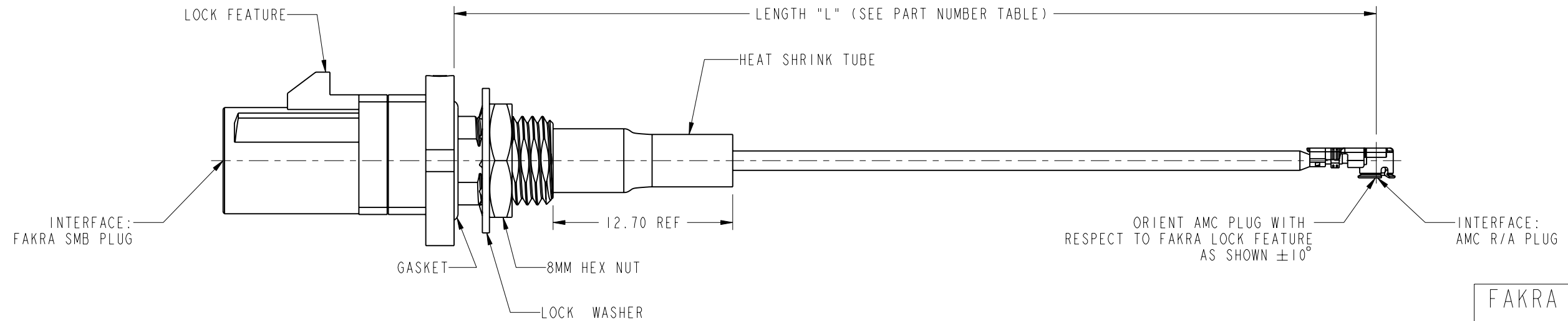
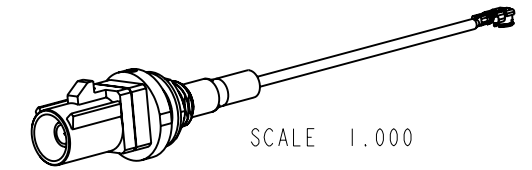

PART NUMBER TABLE		
PART NUMBER	LENGTH "L" MM [IN]	FAKRA KEY CODE
95-820-109-05Z	50.00±5.00 [1.97±.20]	Z
95-820-109-10Z	100.00±5.00 [3.94±.20]	Z
95-820-109-15Z	150.00±5.00 [5.91±.20]	Z
95-820-109-20E	200.00±5.00 [7.87±.20]	E
95-820-109-20Z	200.00±5.00 [7.87±.20]	Z
95-820-109-25Z	250.00±5.00 [9.84±.20]	Z
95-820-109-30Z	300.00±5.00 [11.81±.20]	Z

ADDITIONAL LENGTHS AND FAKRA KEY CODES AVAILABLE BY CHANGING XXX TO DESIRED LENGTH IN MM AND FAKRA KEY CODE. FOR THE DETAIL FAKRA KEY CODE, SEE FAKRA KEY CODE TABLE FOR CLARITY CONTACT AMPHENOL RF MARKETING FOR QUOTE. EXAMPLE: -09B IS 90MM WITH FAKRA KEY CODE "B"

FAKRA KEY TABLE		
KEY CODE	COLOR	RAL NO.
A	JET BLACK	9005
B	CREAM	9001
C	SIGNAL BLUE	5005
D	CLARET VIOLET	4004
E	LEAF GREEN	6002
F	NUT BROWN	8011
G	BLUE GREY	7031
H	HEATHER VIOLET	4003
I	BEIGE	1001
K	CURRY	1027
L	CARMINE RED	3002
M	PASTEL ORANGE	3003
N	PASTEL GREEN	6019
Z	WATER BLUE	5021

DESIGN REQUIREMENTS:

- | | |
|---|--|
| <input checked="" type="checkbox"/> FREQUENCY: DC TO 6 GHz | <input checked="" type="checkbox"/> CONTINUITY |
| <input checked="" type="checkbox"/> VSWR : 1.30 MAX @ 2 GHz
1.50 MAX @ 6 GHz | <input checked="" type="checkbox"/> HI-POT :200 VRMS |
| <input type="checkbox"/> INS. LOSS ----- dB MAX | <input type="checkbox"/> OTHER |

CUSTOMER OUTLINE DRAWING
ALL OTHER SHEETS ARE FOR INTERNAL USE ONLY

UNLESS OTHERWISE SPECIFIED, DIMENSIONS ARE IN METRIC AND TOLERANCES ARE: <0.5mm ±0.05mm 0.5 - 6mm ±0.1mm 6 - 30mm ±0.2mm 30 - 120mm ±0.3mm ANGLES ±1°	MATERIAL SEE NOTES	DRAWN M. ZHANG	DATE 21-Jun-19	TITLE IP-67 FAKRA STR SMB PLUG TO AMC R/A PLUG ON 1.37MM CABLE, VARIOUS LENGTH		Amphenol RF www.amphenolrf.com
	REFERENCE EAR# 8550	ENGINEER S. DUAN	DATE 08-Mar-19	SCALE: 3.0:1.0 SHEET 2 OF 2		
NOTICE - These drawings, specifications, or other data (1) are, and remain the property of Amphenol corp. (2) must be returned upon request; and (3) are confidential and not to be disclosed to any person other than those to whom they are given by Amphenol Corp. the furnishing of these drawings, specifications, or other data by Amphenol Corp., or to any other person to anyone for any purpose is not to be regarded by implication or otherwise in any manner licensing, granting rights to permitting such holder or any other person to manufacture, use or sell any product, process or design, patented or otherwise, that may in any way be related to or disclosed by said drawings, specifications, or other data.	REF: CONFIGURATION LEVEL: In Work	APPROVED S. HSIEH	DATE 21-Jun-19	DWG SIZE B	REV D	DRAWING NO. 95-820-109-XXX
	FINISH	CAD FILE				ITEM NO. 95-820-109-XXX
						PART NO. 95-820-109-XXX