

**TOP VIEW**

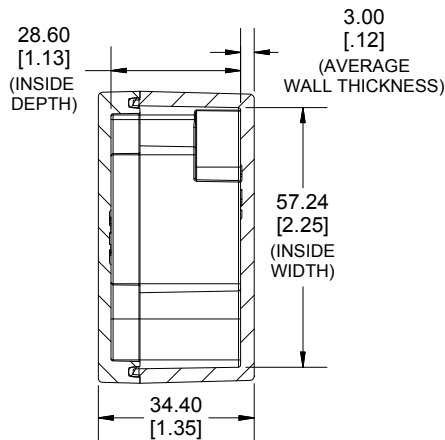

**SECTION A-A  
END VIEW**

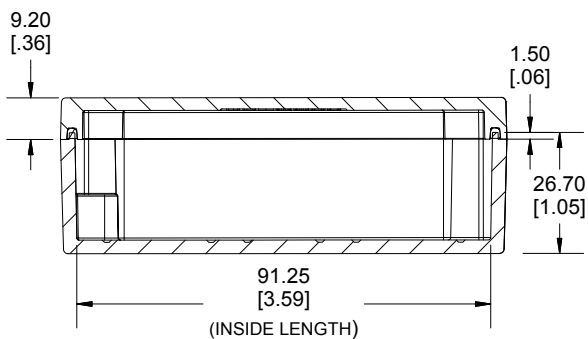

**SECTION B-B  
SIDE VIEW**

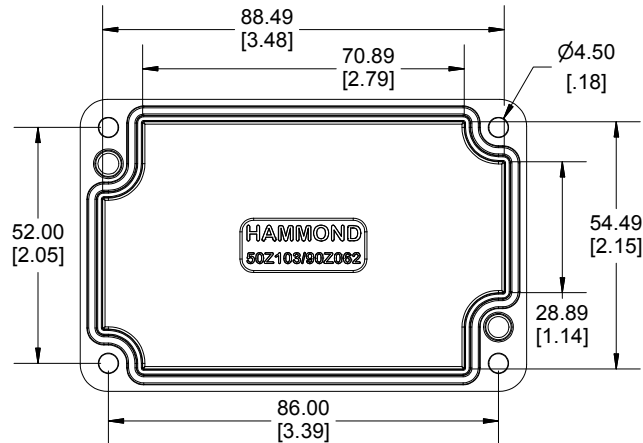

**INSIDE LID**

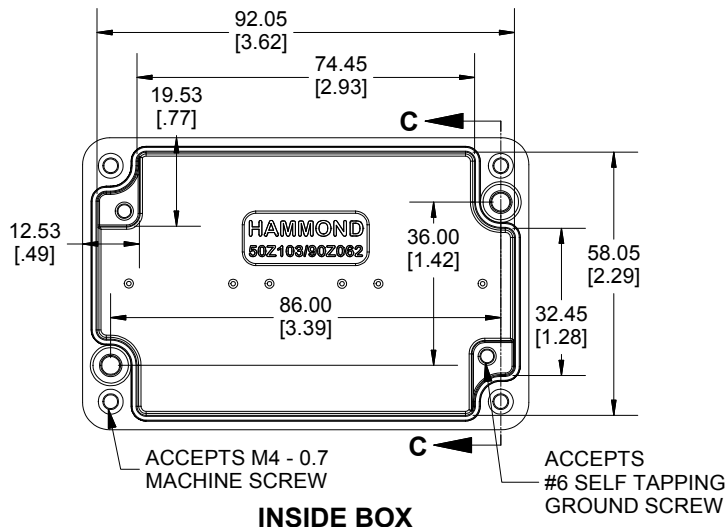

**INSIDE BOX**

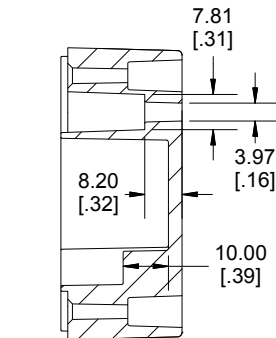

**SECTION C-C  
MOUNTING HOLE**

Dimensions:  
mm  
[inches]

UL US LISTED  
FILE #E71073  
NEMA 4, 4X

Enclosures can be Factory Modified ( Milling, Drilling, Printing etc.)  
Contact Factory [mjm@hammondmfg.com](mailto:mjm@hammondmfg.com) for quotes  
Solid models of this enclosure available in STEP or IGES.  
(Part number and text placement/orientation on our products are subject to change,  
we do not recommend using them as a locating reference for modification purposes)

**NOTE**

Purchased assembly includes box, lid, silicone gasket, and 4 cover screws.  
Box and lid are made from Diecast Aluminum Alloy.

**Screws should not be torqued past 5-7.5 lbf.in ( 50 -75 cN.m)**

**PART NUMBERS**

1550Z103 Enclosure	
Basic Enclosure	1550Z103
Black Enclosure	1550Z103BK
<b>ACCESSORIES</b>	
Pre-Formed Silicone Gasket	1550Z103GASKET

**1550Z103**  
[www.hammondmfg.com](http://www.hammondmfg.com)