

THIS DRAWING IS UNPUBLISHED. RELEASED FOR PUBLICATION  
 © COPYRIGHT - By - ALL RIGHTS RESERVED.

LOC		DIST		REVISIONS			
P	LTR	DESCRIPTION	DATE	DWN	APVD		
	G	UPDATE PER ECO-11-013272	28 JUN 11	CAS	MKS		

SUGGESTED PANEL CUT-OUT

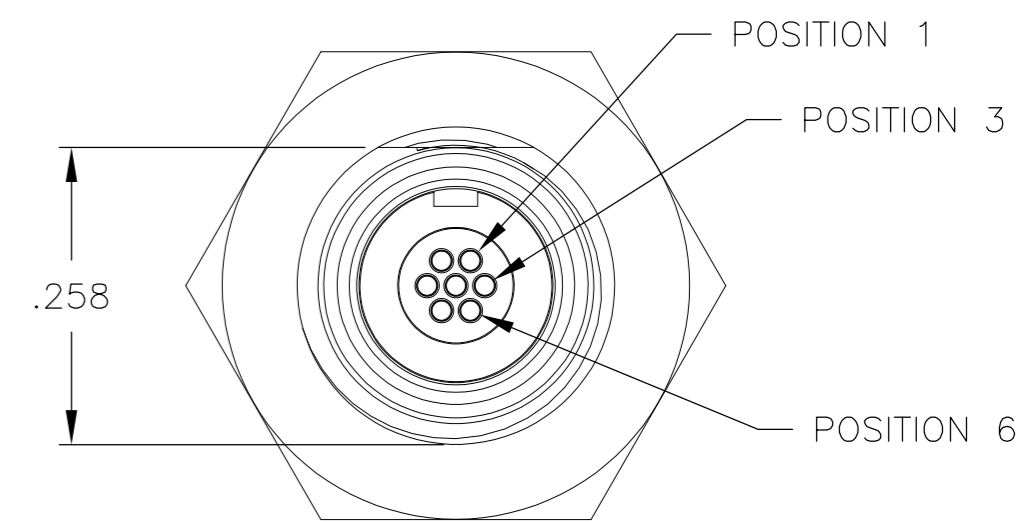
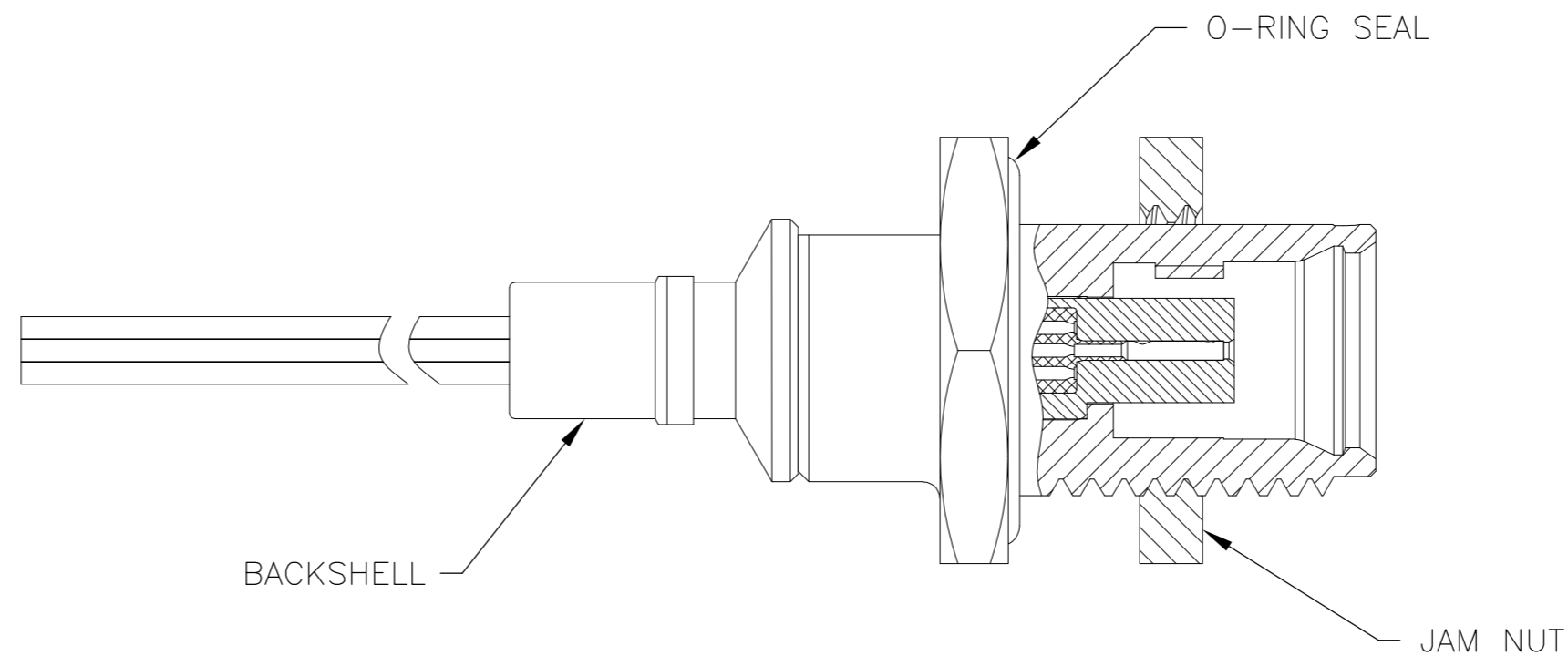
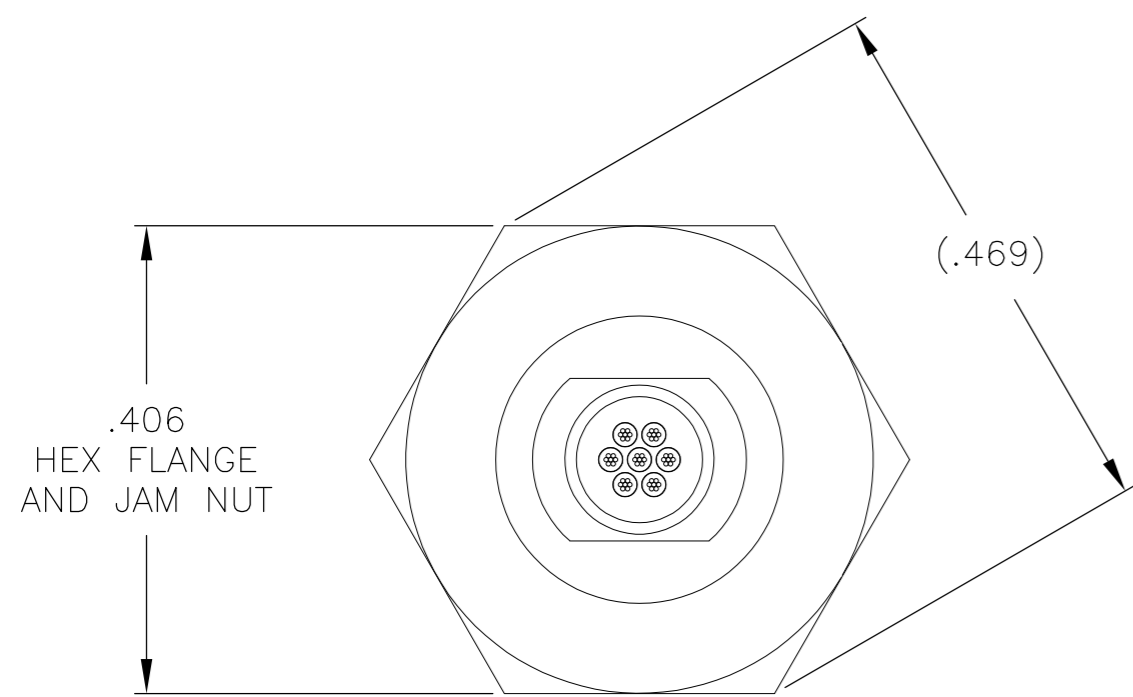
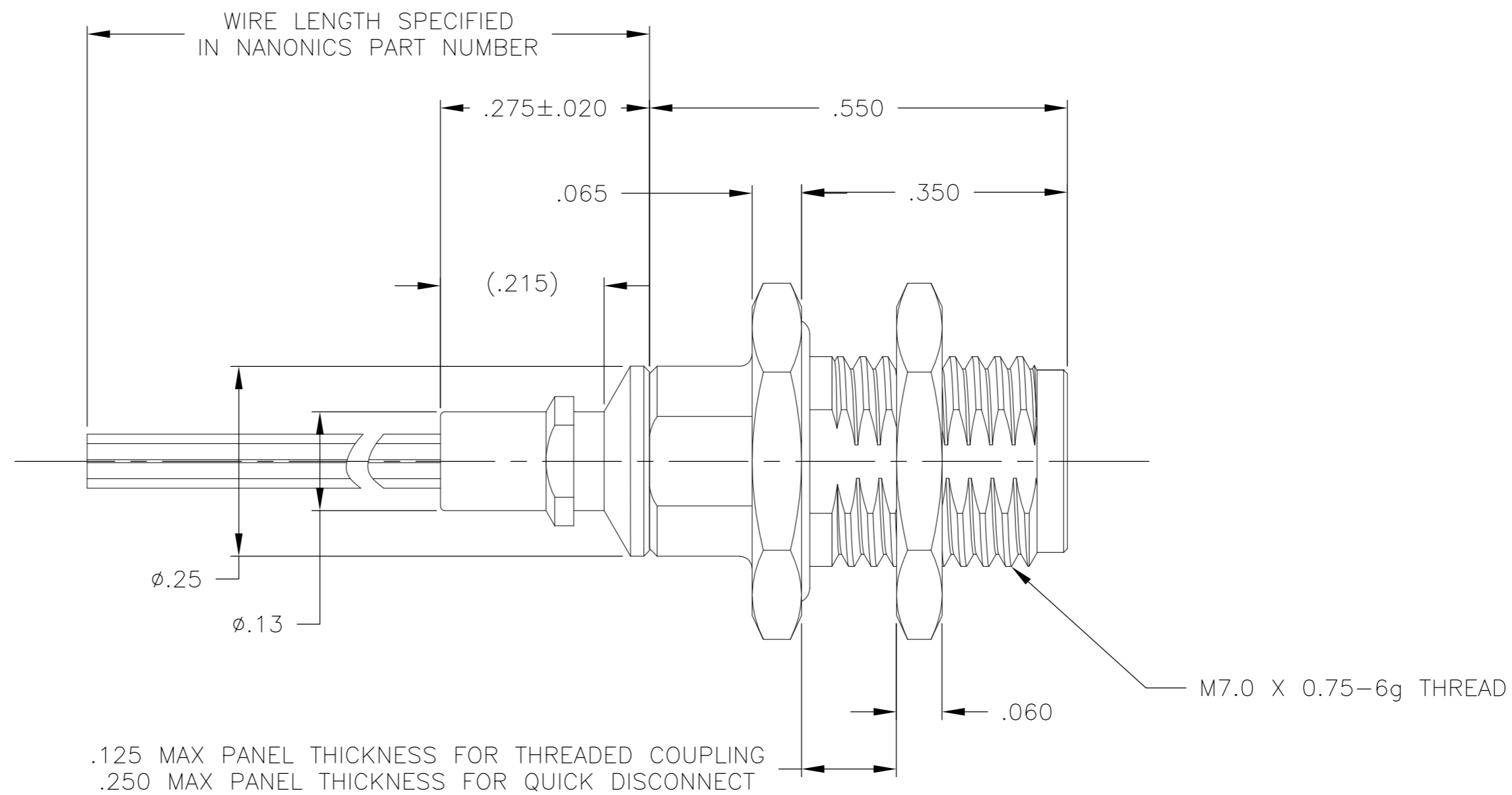
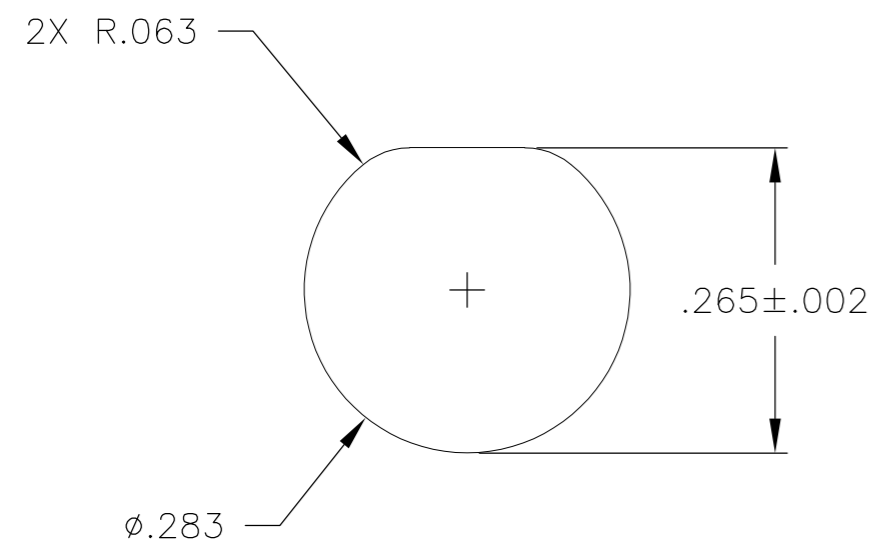

- CONNECTOR BODY, JAM NUT & BACKSHELL MATERIAL: 6061-T6 ALUMINUM, ELECTROLESS NICKEL PLATED PER SAE-AMS-C-26074 OR SAE-AMS-2404E  
 INSULATOR MATERIAL: LIQUID CRYSTAL POLYMER (LCP) PER ASTM D5138 OR POLYPHENYLENE SULFIDE (PPS) PER ASTM D4067  
 O-RING MATERIAL: FLUOROSILICONE
- WIRE TERMINATION: 28 AWG SOLID, 30 AWG STRANDED WIRE OR SMALLER
- BONDING RESISTANCE BETWEEN CONNECTOR BODY AND BACKSHELL TO BE 25 MILLIOHMS MAXIMUM. BACKSHELL TO BE BONDED TO RECEPTACLE SHELL WITH CONDUCTIVE EPOXY.
- LUBRICATE O-RING WITH PARKER SUPER-O-LUBE PRIOR TO INSTALLATION
- THIS DRAWING PREVIOUSLY IDENTIFIED AS NANONICS 303-0093

THIS DRAWING IS A CONTROLLED DOCUMENT.		DWN C. SCHOLL 11 JUN 01	TE Connectivity	
DIMENSIONS: INCHES		CHK M. STORRY 13 JUN 01	RECEPTACLE ASSEMBLY, CIRCULAR, PANEL MOUNT, THREADED COUPLING/QUICK DISCONNECT, STRAIGHT BACKSHELL, METAL, 7 POSITION	
TOLERANCES UNLESS OTHERWISE SPECIFIED: 0 PLC ± - 1 PLC ± - 2 PLC ± .010 3 PLC ± .005 4 PLC ± - ANGLES ± 1°		APVD -	NAME	RESTRICTED TO
MATERIAL SEE NOTES		PRODUCT SPEC -	SIZE A2	CAGE CODE OPJN9
FINISH SEE NOTES		APPLICATION SPEC -	DRAWING NO C=1589685	SCALE 6:1
		WEIGHT -	SHEET 1 of 1	REV G
		CUSTOMER DRAWING		