

- NOTES:**  
 Bemerkungen:
- PACKAGING: LOOSE PIECE INTO CARTON  
 Verpackung: Schüttgut in Karton
  - SUITABLE FOR 1670889  
 Passend zu: 1670889
  - CAVITY 1: 9, 10 AND 18 SUITABLE FOR CONTACT:  
 2.8mm SENSOR FLAT CONTACT  
 0.867543 (STRIP) OR 0.967717 (LOOSE PIECE) 0.10mm TO 0.5mm  
 AND 0.82805 (SINGLE WIRE SEAL) INSULATION DIA. 2.2mm TO 3.0mm  
 Kommer 1: 9, 10 und 18 passend fuer Kontakt:  
 2.8mm Sensorflachkontakt  
 0.867543 (Bänder) oder 0.967717 (Loosepiece) 0.10mm bis 0.5mm  
 und 0.82805 (Einleiterschlinge) Isolationsdurchmesser: 2.2mm bis 3.0mm
  - CAVITY 2 TO 8 AND 11 TO 17 SUITABLE FOR CONTACT:  
 MCON-1.2 CLEAN BODY  
 1.534594 (STRIP) OR 1.534595 (LOOSE PIECE) 0.35mm  
 INSULATION DIA. 1.1mm TO 1.75mm  
 1.394897 (STRIP) OR 1.534063 (LOOSE PIECE) 0.5mm TO 0.75mm  
 INSULATION DIA. 1.1mm TO 1.5mm  
 Kommer 2 bis 8 und 11 bis 17 passend fuer Kontakt:  
 MCON-1.2 CLEAN BODY  
 1.534594 (Bänder) oder 1.534595 (Loosepiece) 0.35mm  
 Isolationsdurchmesser: 1.1mm TO 1.75mm  
 1.394897 (Bänder) oder 1.534063 (Loosepiece) 0.5mm TO 0.75mm  
 Isolationsdurchmesser: 1.1mm TO 1.5mm
  - CONTACT SURFACE ACCORDING TO MATING CONNECTOR  
 Kontaktoberfläche entsprechend dem Gegenstecker
  - ORDER OF ASSEMBLY:  
 1.) CONTACT MOUNTING  
 2.) 2-LOCK MOUNTING  
 3.) LEVER IN PRE LOCKED POSITION  
 Reihenfolge der Bestueckung:  
 1.) Kontaktbestueckung  
 2.) 2-Kontaktsicherung  
 3.) Hebel in Vorraststellung
  - INTERFACE DRAWING NO 114-18801  
 Schnittstellenzeichnung Nr. 114-18801

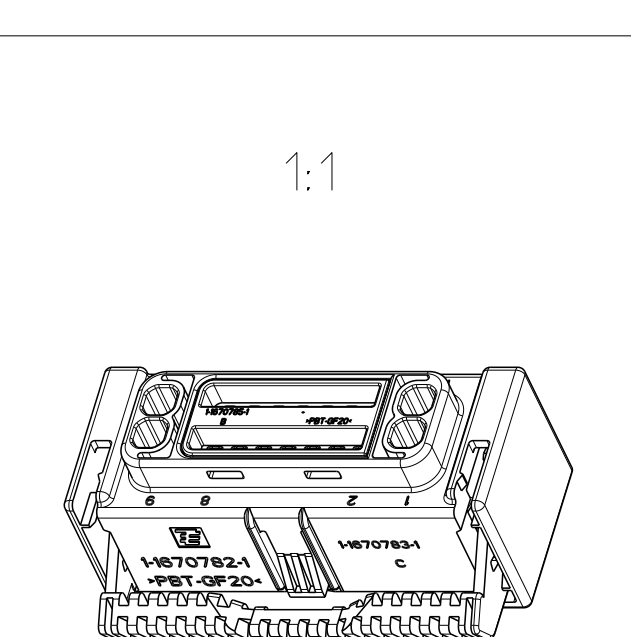

AS SHOWN (DELIVERY CONDITION)  
 WIE GEZEICHNET (Anlieferungszustand)

REV.	DATE	DESCRIPTION	BY	CHK	APPD.
F	14MAR2012	LOCKING LOWER PART MODIFY			
F.1	04NOV2012	2-LOCK INFO CORRECTED			
G	19MAY2013	SOCKET HOUSING MODIFY			
H	15APR2015	FASE ON 2.8 CAVITYS ADDED			

**CODINGS**  
 Kodierungen  
 2:1

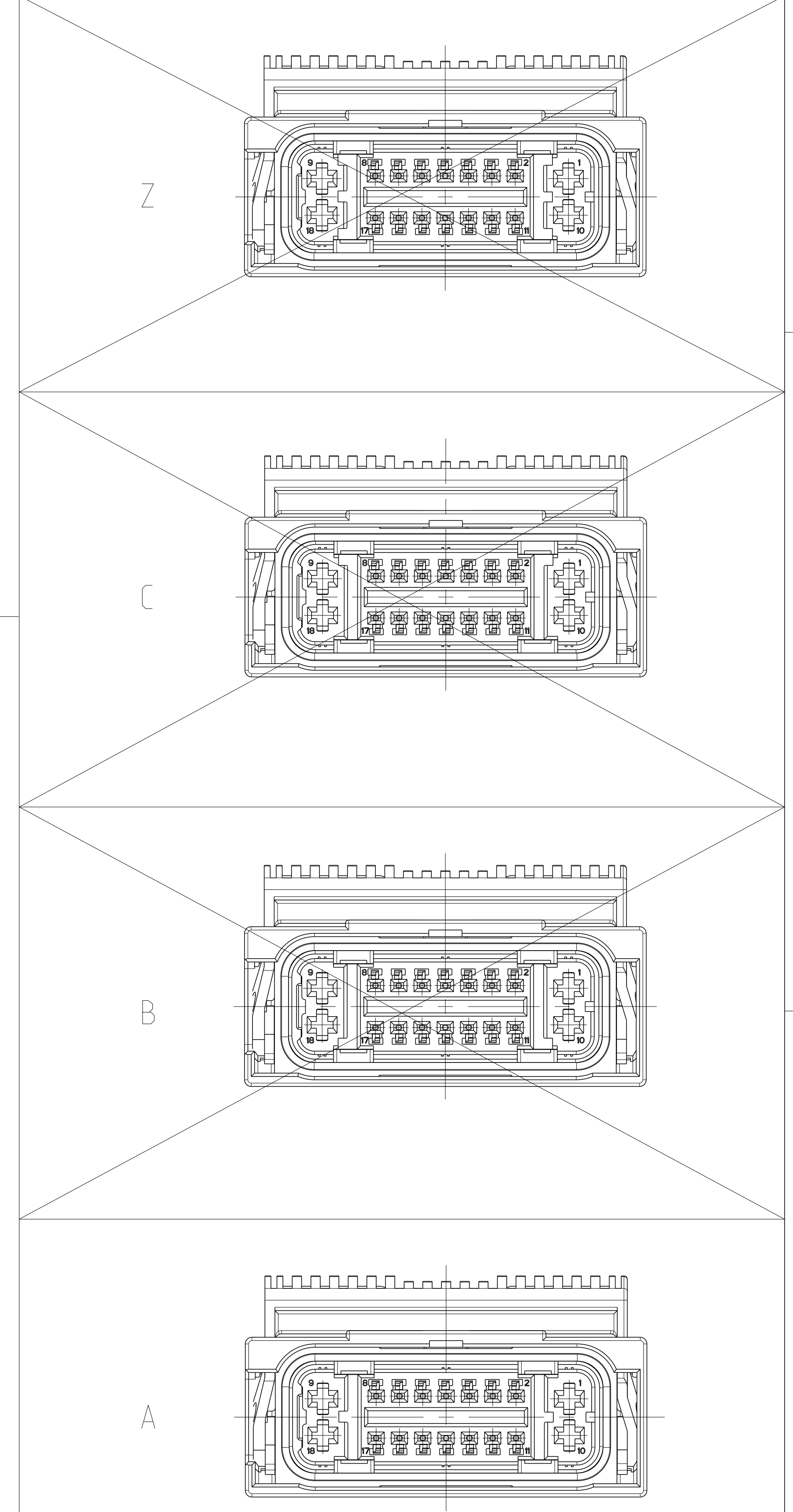

REV.	QTY	DESCRIPTION	MATERIAL	COLOR	ITEM NO.
1	1	LEVER	PBT-GF20	BLACK	6
1	1	RADIAL SEAL	ELASTOSIL	NATURE	5
1	1	FAMILY SEAL, MCON-1.2 CB	ELASTOSIL	NATURE	4
1	1	COVER FAMILY SEAL, MCON-1.2 CB	PBT-GF20	BLACK	3
1	1	18POS. MIXED REC HSG. LOWER PART	PBT-GF30	WATER BLUE	2
1	1	18POS. MIXED REC HSG. UPPER PART	PBT-GF20	BLACK	1
1	1	LEVER	PBT-GF20	BLACK	6
1	1	RADIAL SEAL	ELASTOSIL	NATURE	5
1	1	FAMILY SEAL, MCON-1.2 CB	ELASTOSIL	NATURE	4
1	1	COVER FAMILY SEAL, MCON-1.2 CB	PBT-GF20	BLACK	3
1	1	18POS. MIXED REC HSG. LOWER PART	PBT-GF30	BLUE	2
1	1	18POS. MIXED REC HSG. UPPER PART	PBT-GF20	BLACK	1
1	1	LEVER	PBT-GF20	BLACK	6
1	1	RADIAL SEAL	ELASTOSIL	NATURE	5
1	1	FAMILY SEAL, MCON-1.2 CB	ELASTOSIL	NATURE	4
1	1	COVER FAMILY SEAL, MCON-1.2 CB	PBT-GF20	BLACK	3
1	1	18POS. MIXED REC HSG. LOWER PART	PBT-GF30	BLACK	2
1	1	18POS. MIXED REC HSG. UPPER PART	PBT-GF20	BLACK	1

1-1670782-1	H	H	1-1670782-1	H
DATE	10DEC2005	BY	Nickelberg	10DEC2005
CHK	Ryll	APPD.	OSJAN2007	
PRODUCT SPEC	105-9A.094	APPLICATION SPEC	114-18853	
WEIGHT		SCALE	5:1	
CUSTOMER DRAWING		SHEET	1 of 1	REV

**STE** TE Connectivity  
 18POS. MIXED REC HSG. ASSY  
 18polig Buchsengehäuse Assy