

Automotive Power and Motor Drive

Evaluation Kit for Stepping Motor Driver

BD63800MUF-EVK-002

The ROHM BD63800MUF-C is an AEC-Q100 automotive qualified bipolar low-consumption stepping motor driver that is driven by PWM current. It is suitable for Automotive applications such as Head-up Display, LED Headlight, Heat pump and Intake Air Control Valve. This EVK enables the performance evaluation of this IC in research and development laboratories.

● Description

BD63800MUF-EVK-002 is an evaluation board for the Automotive Stepping Motor Driver IC. Also, a GUI can be provided by ROHM for easy SPI register configuration.

The key component of the evaluation board is the ROHM BD63800MUF-C which have the following specifications and features:

● BD63800MUF-C Key Specifications:

- Supply voltage range.....6.0 to 28 V
- Output Current Rating (peak)1.35 A
- Output Current Rating (DC)1.20 A
- Output On Resistance (up and down)0.75 Ω
- VCC quiescent supply current (max)10 μA

BD63800MUF-C operates with single power supply which can simplify the set design.

● BD63800MUF-C Features:

- CLK-IN and SPI-IN Drive mode
- Supported Modes:
 - Full step, 1/2, 1/4, 1/8, 1/16 and 1/32 step
- Current Decay Mode Switch Function
 - Mix Decay: Linear Adjustment of
Slow Decay / Fast Decay Ratio
 - Auto Decay: Automatic Switch of
Slow Decay / Fast Decay

Further features and protections are referred to the datasheet.



Figure 1: BD63800MUF-EVK-002

● EVK Features

- Plug & Play Stepping Motor Evaluation Kit
- Graphical User Interface application software
Easy to set/read register.
[Operating System: Windows10]
- External Switches for pin setting.
Open or High settings
- Test pins for easy signal monitoring

Contents

- 1 Introduction 3
- 2 Safety Instructions 4
 - 2.1 Warnings 4
 - 2.2 Instructions for Safe Use..... 4
- 3 Hardware Description 5
 - 3.1 Schematic..... 5
 - 3.2 PCB Layout and Component Placement 6
 - 3.3 Bill of Materials..... 9
- 4 Operating Instructions 10
 - 4.1 Hardware 10
 - 4.2 Software 12

1 Introduction

This evaluation kit (EVK) manual describes the usage of ROHM's BD63800MUF-EVK-002. The purpose of the EVK is to allow the test and evaluation of the stepping motor driver IC BD63800MUF-C in professional research and development environments. This document provides guidelines to quickly setup the hardware and software for fast and easy stepping motor driver IC performance evaluation.

- BD63800MUF-C evaluation board [BD63800MUF-EVK-002]
- USB cable (USB2.0 A-Male to C-Male)
- BD63800MUF-C GUI control software (MS Windows)
- USB Driver



USB Cable
(A-male to C-male)

For operation of the EVK the following additional items will be required:

- PC with operating system Windows 10 or higher
- Laboratory DC power supplies: 12 V(typ.)/1.5 A(min.) and 5 V/100 mA(min.)
- Load (e.g. Bipolar DC step motor)
- Connecting cables between DC power supply and boards
- Clock generator: Input 5 V to 0 V clock signal for CLK pin. [Optional]

Figure 2 shows the setup boards and instruments as mentioned above. Detailed information for connection is described on section 4.1[Hardware]. For receiving the BD63800MUF-C GUI control software please get in touch with your local ROHM sales office or use the general ROHM customer support system.

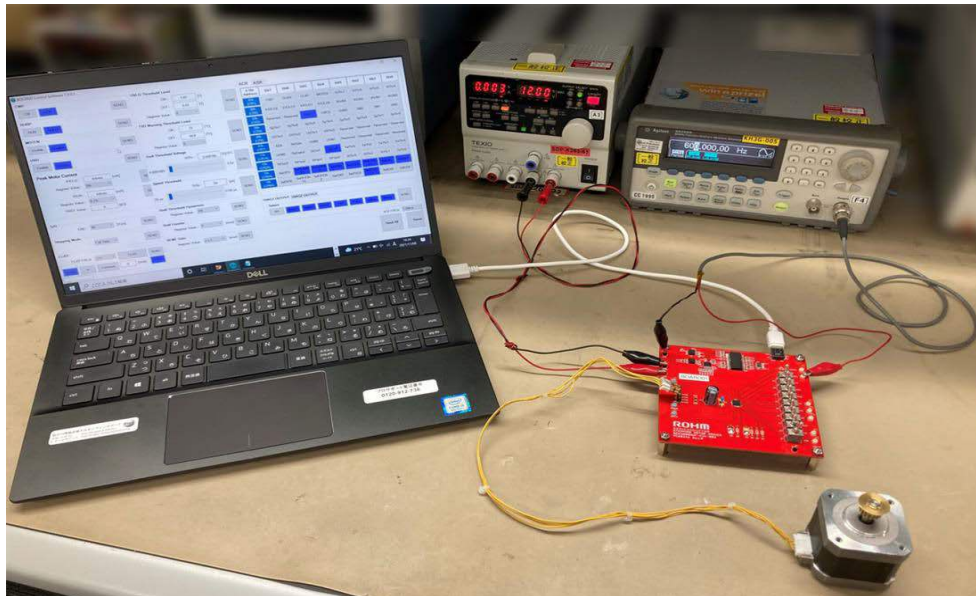

Figure 2: BD63800MUF-EVK-002 Evaluation Setup.

2 Safety Instructions

2.1 Warnings

- This evaluation kit must only be operated by trained professionals.
- This evaluation kit should be operated in a well ventilated environment and, if used inside a case, the case should not be covered.
- This evaluation kit should be placed on a stable, flat, non-conductive surface in use and should not be contacted by conductive items.
- All peripherals used with the evaluation kit should comply with relevant standards for the country of use and be marked accordingly to ensure that safety and performance requirements are met.
- Where peripherals are connected that do not include the cable or connector, the cable or connector used must offer adequate insulation and operation in order that the requirements of the relevant performance and safety are met.
- The connection of incompatible devices to the evaluation kit may affect compliance or result in damage to the unit and invalidate the warranty.

2.2 Instructions for Safe Use

- Do not expose the evaluation kit to water, moisture or place on a conductive surface whilst in operation.
- Take care whilst handling to avoid mechanical or electrical damage to the printed circuit board and components.
- Avoid handling the printed circuit board while it is powered. Only handle by the edges to minimize the risk of electrostatic discharge damage.
- Do not short any outputs to each other, to the supply or to GND.
- Do not operate the evaluation kit outside its specified ratings.
- Take care to monitor the PCB and IC temperatures in particular when operating with high power loads and do not exceed the absolute maximum ratings of all components.

3 Hardware Description

3.1 Schematic

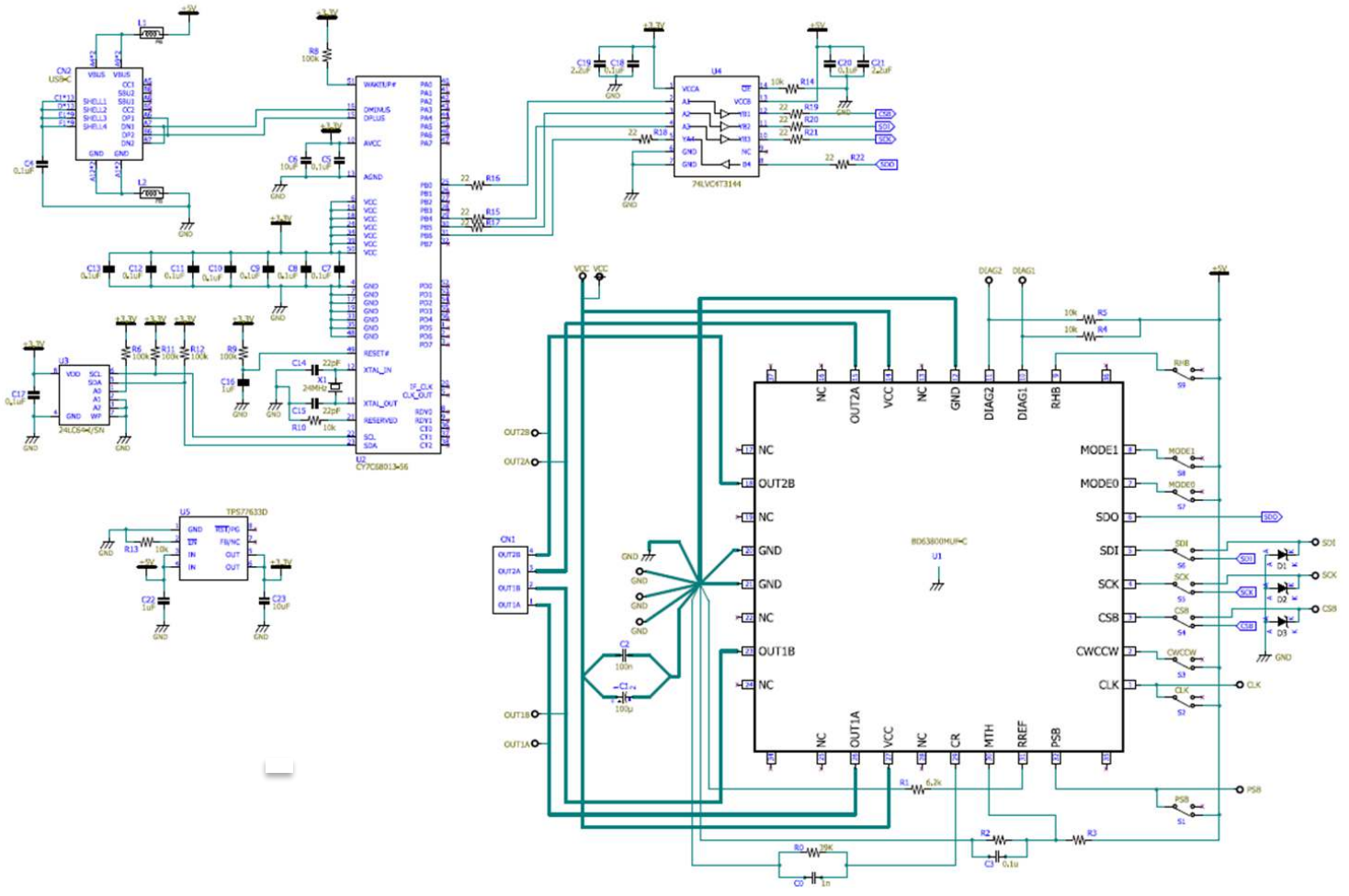

Figure 3: Evaluation Board Schematic

3.2 PCB Layout and Component Placement

Please note that the layout of this EVK is not optimized in terms of thermal performance or signal routing.

The focus is more on enabling easy test by adding test points to each signal. All pictures are viewed as seen from TOP side.

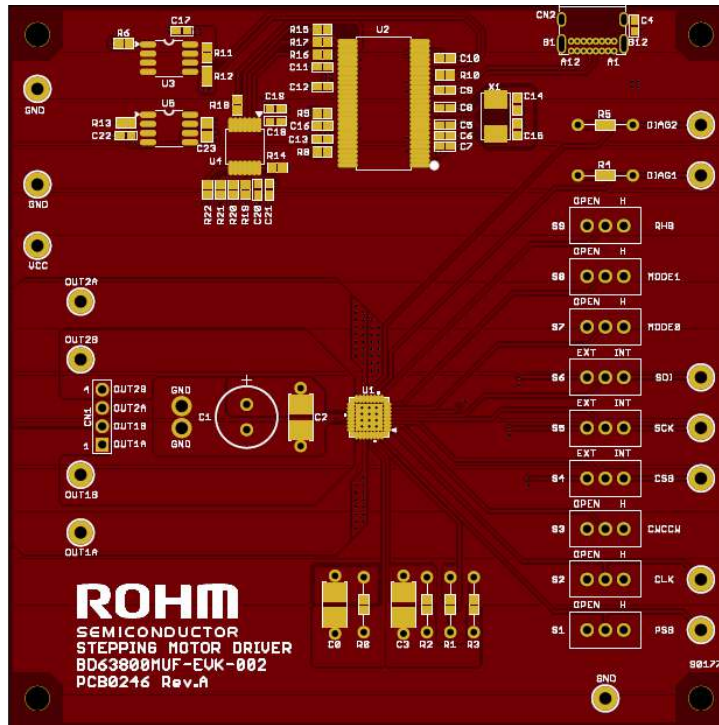

Figure 4: TOP side PCB with Pads and Silkscreen

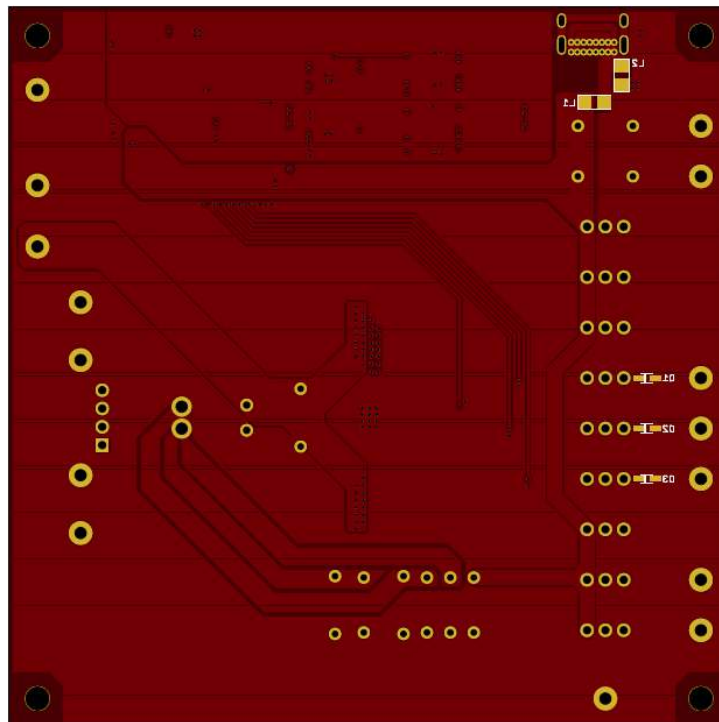

Figure 5: Bottom side with Pads and Silkscreen

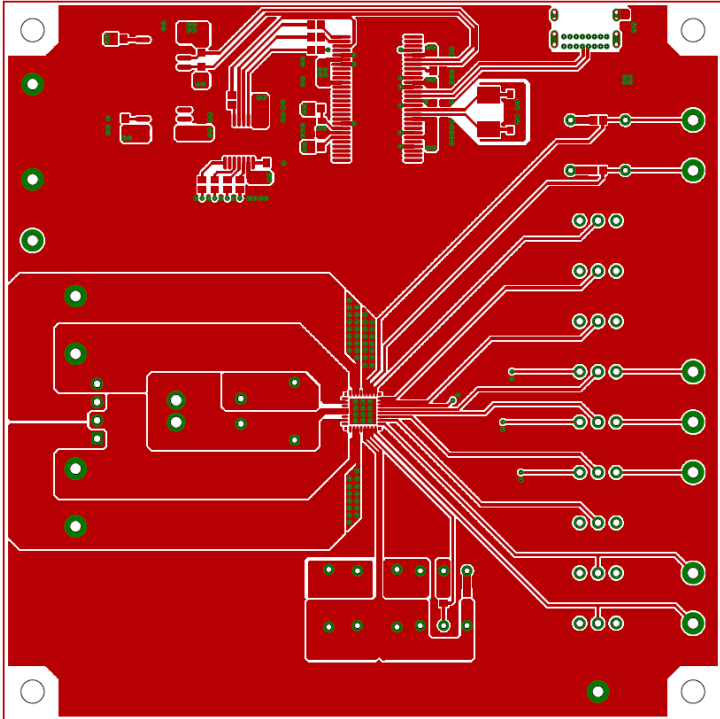

Figure 6: Top layer

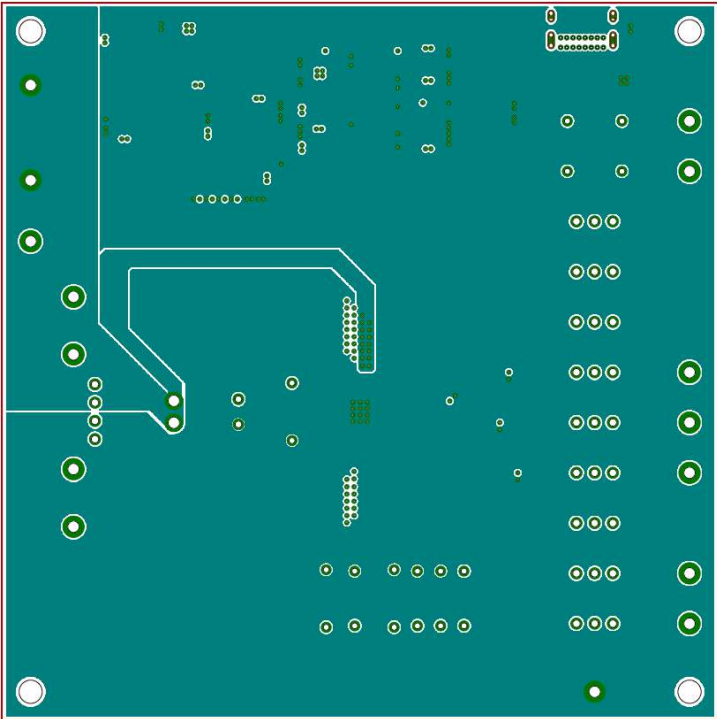

Figure 7: 2nd layer

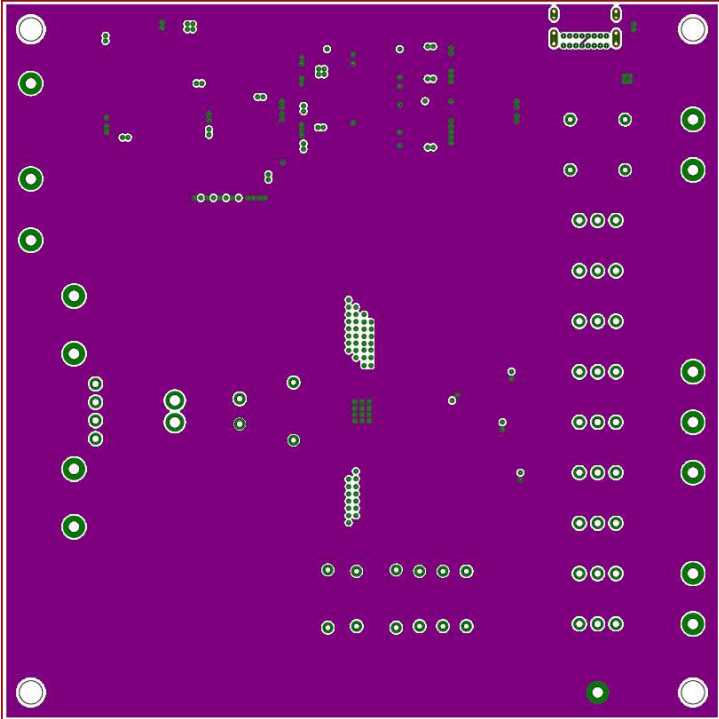

Figure 8: 3rd layer

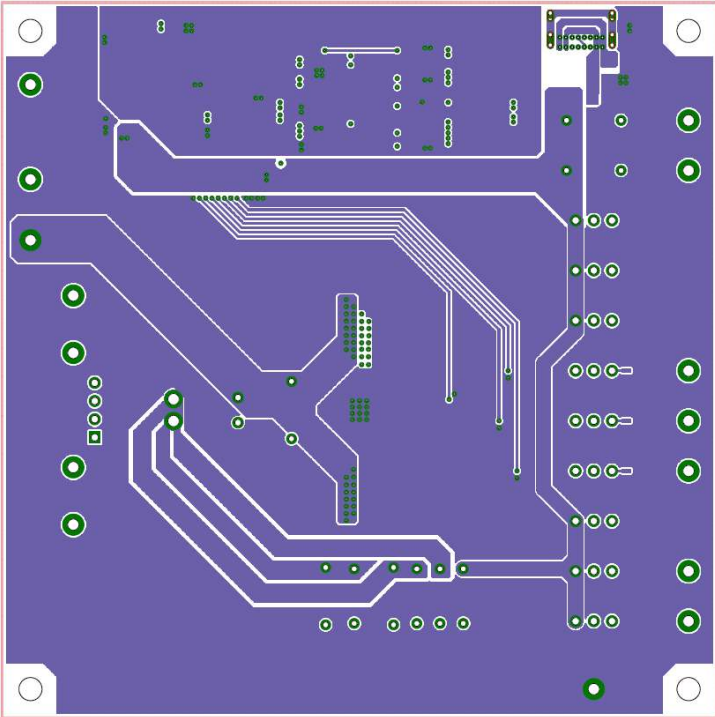

Figure 9: Bottom layer

3.3 Bill of Materials

Comp. Name	Value	Type	Quantity
For BD63800MUF-C			
C0	1 nF	Capacitor, Surface Mount/Through Hole	1
C1	100 μ F	Capacitor, Through Hole	1
C2	100 nF	Capacitor, Surface Mount/Through Hole	1
C3	0.1 μ F	Capacitor, Surface Mount/Through Hole	1
CN1	1 row x 4 pin Connector	2.54mm pitch, 1.0mm Hole	1
R0	39 k Ω	Resistor, Surface Mount	1
R1	6.2 k Ω	Resistor, Surface Mount	1
R4, R5	10 k Ω	Resistor, Surface Mount/Through Hole	2
R2, R3	Open	Resistor, Surface Mount	2
S1, S2, S3, S4, S5, S6, S7, S8, S9	SPDT switch	2.54mm pitch, 1.0mm Hole	9
U1	BD63800MUF-C	IC for Stepper Motor Driver VQFN32FBV050	1
For Microcontroller			
C4, C5, C7, C8, C9, C10, C11, C12, C13, C17, C18, C20	0.1 μ F	Capacitor, Surface Mount	12
C6	10 μ F	Capacitor, Surface Mount	1
C14, C15	22 pF	Capacitor, Surface Mount	2
C16, C22	1 μ F	Capacitor, Surface Mount	2
C19, C21	2.2 μ F	Capacitor, Surface Mount	2
C23	10 μ F	Capacitor, Surface Mount	1
CN2	2 row x 10 pin Connector	2.54mm pitch, 1.0mm Hole	1
D1, D2, D3	7.5V	Zener diode, Surface Mount	3
L1, L2	31 Ω	Ferrite bead, Surface Mount	2
R10, R13, R14	10 k Ω	Resistor, Surface Mount	3
R6, R8, R9, R11, R12	100 k Ω	Resistor, Surface Mount	5
R15, R16, R17, R18, R19, R20, R21, R22	22 Ω	Resistor, Surface Mount	8
U2	CY7C68013A-56PVXC	IC MCU USB PERIPH HI SPD 56SSOP	1
U3	24LC64F-I/SN	IC EEPROM 64KBIT I2C 8SOIC	1
U4	74LVC4T3144PW-Q10J	IC BUF NON-INVERT 5.5V 14TSSOPLINEAR 3.3V 500MA 8SOIC	1
U5	TPS77533D	IC REG LINEAR 3.3V 500MA 8SOIC	1
X1	ECS-240-20-23A-EN-TR	CRYSTAL 24.0000MHZ 20PF SMD	1

Table 1: Evaluation Board Bill of Materials

4 Operating Instructions

4.1 Hardware

Before start to connect, make sure to turn off all equipment for your safety.

Connect the cables as followings:

[BD63800MUF-EVK-002]

1. Connect USB Cable(C-Male) to CN2.
2. Connect DC Power Supply [6 to 28 V / 1.5 A (min.)] to VCC(Red) and GND(Black) terminal.
3. Connect Load to Outputs (OUT1A, OUT1B, OUT2A, OUT2B).

To make sure the correct connection, please check the install manual of the load.

4. Connect Clock Signal Generator to CLK terminal. [Option: In case of use the CLK terminal]

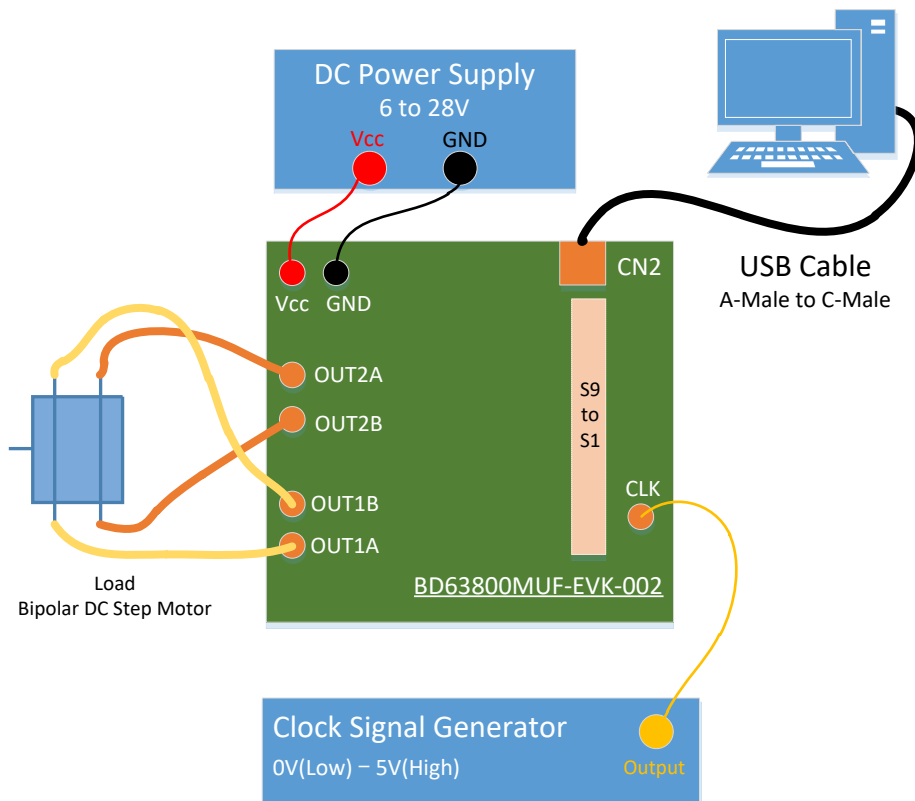

Figure 10: BD63800MUF-EVK-002 Setup

- Set the All toggle switches (S1 to S9) to "Open" settings.

S1:Open, S2:Open, S3:Open, S4:Open, S5:Open, S6:Open, S7:Open, S8:Open, S9:Open

All toggle switches are able to select "Open" or "H".

Open: Pin status depend on the external test pin and internal pull-up/pull-down resistor.

Switch to inner side of the board.

H: Pin status is forced to High (5V).

Please don't connect anything to the external test pin for the switch.

Switch to outer side of the board.



Toggle switch: (S1 for PSB)

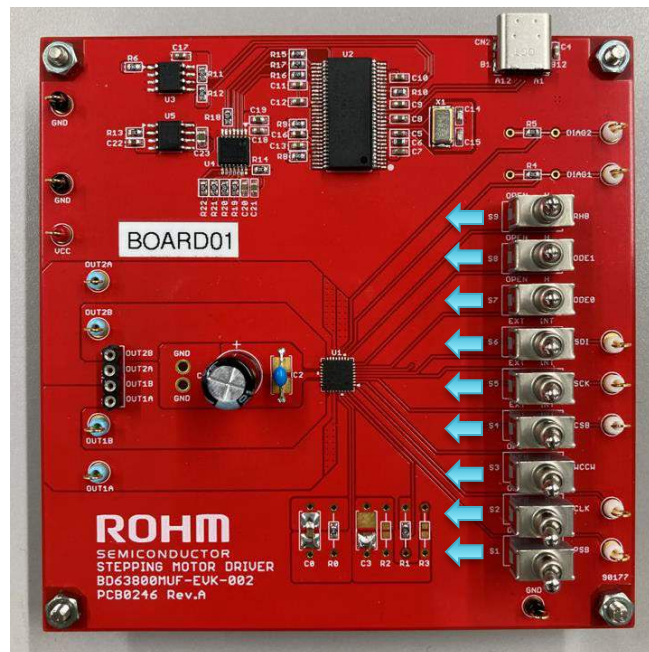

- S9: Toggle to "Open"
- S8: Toggle to "Open"
- S7: Toggle to "Open"
- S6: Toggle to "Open"
- S5: Toggle to "Open"
- S4: Toggle to "Open"
- S3: Toggle to "Open"
- S2: Toggle to "Open"
- S1: Toggle to "Open"

Figure 11: Toggle Switch initial setting

Although the maximum operating supply voltage of the motor driver IC BD63800MUF-C is 40 V it is also the absolute maximum value of the IC. So, if you use higher supply voltage than typical please make sure to include enough margin for fluctuation or voltage spikes to never exceed the absolute maximum ratings.

Please operate the EVK at room temperature only. The maximum load current should be limited by thermal performance of the components. Please take care to measure the temperature of the EVK components when applying your desired settings and load.

4.2 Software

BD63800MUF-EVK-002 can be controlled by SPI commands and the external setting pins. BD63800MUF-C GUI (Graphical User Interface) software is enabled to set command and read status register easily. Followings are the setting parameter examples on the software. For detail of the software manual, receiving software, please contact to your ROHM sales office or use the general ROHM customer support system.

Software Setting items:

- Drive mode selection
 - Motor Enable / disable
 - Motor Rotation Direction [Clockwise / Counterclockwise]
 - Driving / Hold mode
 - Operation on under voltage state [Open / Hold]
 - CLK-IN / SPI-IN mode
- Drive and protection parameter
 - Excitation mode
 - Peak motor current
 - Slew rate
 - Clock speed for SPI-IN mode
 - Protection parameter (UVLO, TSD, Stall)

Revision History

Date	Revision Number	Description
2022. 2	1.0	New Release

Notes

- 1) The information contained herein is subject to change without notice.
- 2) Before you use our Products, please contact our sales representative and verify the latest specifications :
- 3) Although ROHM is continuously working to improve product reliability and quality, semiconductors can break down and malfunction due to various factors.
Therefore, in order to prevent personal injury or fire arising from failure, please take safety measures such as complying with the derating characteristics, implementing redundant and fire prevention designs, and utilizing backups and fail-safe procedures. ROHM shall have no responsibility for any damages arising out of the use of our Products beyond the rating specified by ROHM.
- 4) Examples of application circuits, circuit constants and any other information contained herein are provided only to illustrate the standard usage and operations of the Products. The peripheral conditions must be taken into account when designing circuits for mass production.
- 5) The technical information specified herein is intended only to show the typical functions of and examples of application circuits for the Products. ROHM does not grant you, explicitly or implicitly, any license to use or exercise intellectual property or other rights held by ROHM or any other parties. ROHM shall have no responsibility whatsoever for any dispute arising out of the use of such technical information.
- 6) The Products specified in this document are not designed to be radiation tolerant.
- 7) For use of our Products in applications requiring a high degree of reliability (as exemplified below), please contact and consult with a ROHM representative : transportation equipment (i.e. cars, ships, trains), primary communication equipment, traffic lights, fire/crime prevention, safety equipment, medical systems, servers, solar cells, and power transmission systems.
- 8) Do not use our Products in applications requiring extremely high reliability, such as aerospace equipment, nuclear power control systems, and submarine repeaters.
- 9) ROHM shall have no responsibility for any damages or injury arising from non-compliance with the recommended usage conditions and specifications contained herein.
- 10) ROHM has used reasonable care to ensure the accuracy of the information contained in this document. However, ROHM does not warrants that such information is error-free, and ROHM shall have no responsibility for any damages arising from any inaccuracy or misprint of such information.
- 11) Please use the Products in accordance with any applicable environmental laws and regulations, such as the RoHS Directive. For more details, including RoHS compatibility, please contact a ROHM sales office. ROHM shall have no responsibility for any damages or losses resulting non-compliance with any applicable laws or regulations.
- 12) When providing our Products and technologies contained in this document to other countries, you must abide by the procedures and provisions stipulated in all applicable export laws and regulations, including without limitation the US Export Administration Regulations and the Foreign Exchange and Foreign Trade Act.
- 13) This document, in part or in whole, may not be reprinted or reproduced without prior consent of ROHM.



Thank you for your accessing to ROHM product informations.
More detail product informations and catalogs are available, please contact us.

ROHM Customer Support System

<http://www.rohm.com/contact/>