

Revision level		Revision Record	Changed	Date	Approved	Date
part	drawing					
—	01	See ECN 011616	A.A.C.	08/27/10	K.A.C.	08/31/10

HOUSING:
POLYCARBONATE

Material

Dimension tolerances
unless otherwise specified

.XXXX = ± .0130

.XXX = ± .300

.XX = ± .30

.X = ± .2

∠ = ± 0.5 °

Dimension Units mm

Stripping Length:

11mm(.45 in)

Wire Range:

0.5–2.5 mm²

Solid/Stranded(VDE)

(12–22 AWG

Solid/Stranded) MAX 7

Cores

Working Temp:

–30°C(–22°F)to

110°C(230°F) (VDE)

–22°F(–30°C) to

221°F(105°C) (cULus)

Voltage:

600V(cULus)

Current:

24A

Certifications:

UL E316080, KEMA–KEUR

VDE,FIMKO,ENEC,CEBEC,

NEMKO, DEMKO

PERFORMANCE
SPECIFICATION

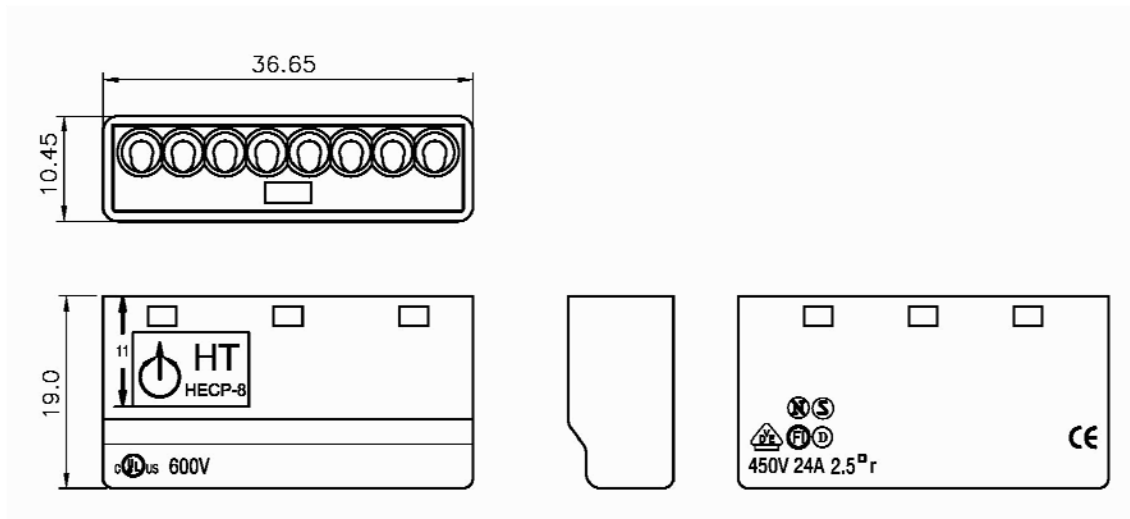

ACAD MECH
2009

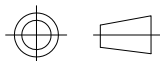

Drawn A.A.C. 08/27/10

Approved K.A..C. 08/31/10

Scale: NTS

Computer File Number
WC\CST\XWC-HPR017CSU_01

Title Phase: Production

ALL PROPRIETARY RIGHTS IN THE
SUBJECT MATTER SHOWN ON THIS
DRAWING ARE EXCLUSIVE
PROPERTY OF HELLERMANNTYTON

HellermannTyton

7930 N. Faulkner Rd.
Milwaukee, WI 53224
Ph: (414) 355–1130
Fx: (414) 362–8342

**HECP-8
HELACON PLUS
PUSH-IN WIRE CONNECTOR**

Drawing–No

XWC-HPR017CSU

Format

AH

Sheet 1 of 1