



Capteur de Fenêtres-Feuillures Sensors for window frames

PW

- Capteur de proximité magnétique à ampoule REED :
Ouvert, Fermé, inverseur, boucle de sécurité.
- Développé pour détection de l'état de la fenêtre : Ouverte / Fermée
- Clip de verrouillage compris dans la référence PW



- *Magnetic proximity sensor with REED switch*
Normally Open (NO), Normally Closed (NC), Change-over contact, Safety current loop.
- *Developed to detect position of the window : Open / Closed.*
- *Locking clip included in PW reference*

Dimensions

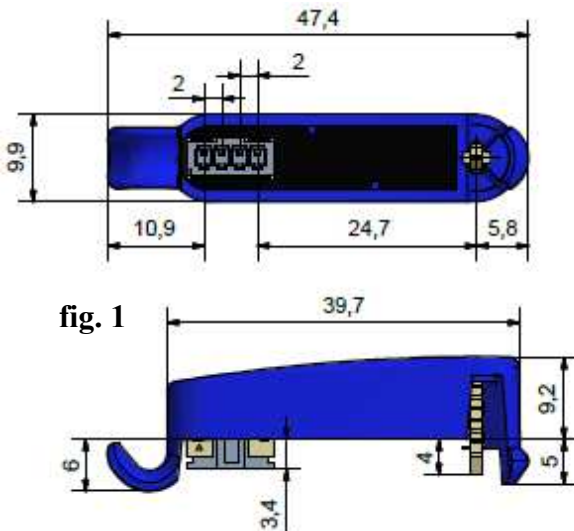

Caractéristiques / Specifications

	PWA	PWB/PWC
Puissance maximum commutable / Max switching power	10 VA	3 VA
Courant maximum commutable / Max switching current	0,4 A	0,25 A
Tension maximale commutable / Max switching voltage	100 Vdc	100 Vdc
Tension de tenue / Dielectric strength	250 Vdc	150 Vdc
Courant passant maximum / Maximum carried current	1 A	0,5 A
Résistance de contact Reed / Reed Contact resistance only	150 mΩ	150 mΩ
Résistance d'isolement / Insulation resistance	10 ¹² Ω	10 ⁹ Ω
Température de fonctionnement / Operating Temperature	-40 / +70 °C	
Dimensions / Dimensions	fig. 1	
Distances de détection / Operating distances	fig. 2	
Matériau du boîtier / Housing material	PA6	

Plans de perçage - épaisseur de 1 à 2 mm / Drilling plan - thickness of 1 to 2 mm

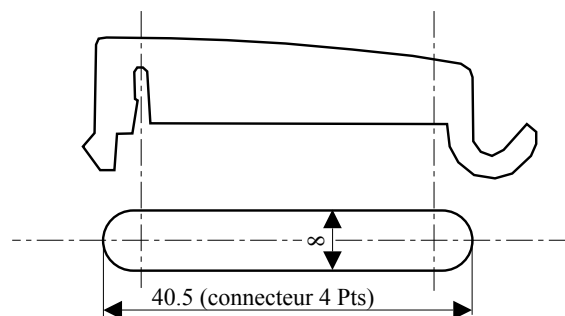

Partie capteur sur le dormant de la fenêtre - Partie Aimant sur l'ouvrant. /
Sensor mounted on the fixed part and magnet on the moving part.

Proud to serve you

celduc[®]
r e l a i s

Fonctions / Functions :

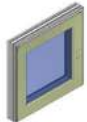
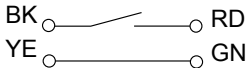
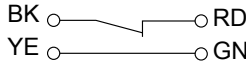
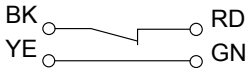
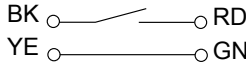
Réf.captteur Sensor Ref.	Nature du contact / Type of contact.	Etat fenêtre / Window status.	
		Etat des contacts / Contact(s) status.	
PWC01500	Inverseur (Contact NO+ Contact NF) <i>Change-over (1 NO+1NC contacts)</i>		
PWA11500	• NO (contact ouvert en absence d'aimant) <i>NO (contact is open if no magnet)</i> • Boucle de sécurité (safety loop)		
PWB11500	• NF (contact fermé en absence d'aimant) <i>NC (contact is closed if no magnet)</i> • Boucle de sécurité (safety loop)		

RD = Red / Rouge.
BK = Black / Noir.
YE = Yellow / Jaune.
GN = Green / Vert.

Accessoires / Accessories:

Référence	Désignation / Designation :	
UZ189538	Aimant Ferrite (à coller) / <i>Magnet Ferrite (to be glued)</i>	Lg 18mm x lg 9.5mm ép. 3.8mm
UR124540	Aimant NdFeB (à visser) / <i>Magnet NdFeB (to be screwed)</i>	Ø12 - trou(holl)4,5 - ép/thickness 4mm
PW520000	Aimant boîtier PW (à clipser) / <i>Magnet PW (to be clipped)</i>	Ø5 Lg 20mm-NdFeB
2YB40080	Câble / <i>cabl</i> e: 4x0.22 ² Lg 8m + connecteur PHR4	Uniquement pour connecteur 4 pts. <i>Only for 4 pins connector.</i>
1LM00100	Sachet Clips de Verrouillage / <i>Bag locking clips (16pcs)</i>	Clip Lg 11mm

Type de fenêtres / Kind of windows:

• Fenêtre à la française
(French window)



• à soufflet
(Hopper window)



• coulissante
(Sliding window)



• à l'italienne
(awning window)



Proud to serve you

All technical characteristics are subject to change without previous notice.
Caractéristiques sujettes à modifications sans préavis.

celduc®
r e l a i s

Principe de Montage / Steps for mounting :

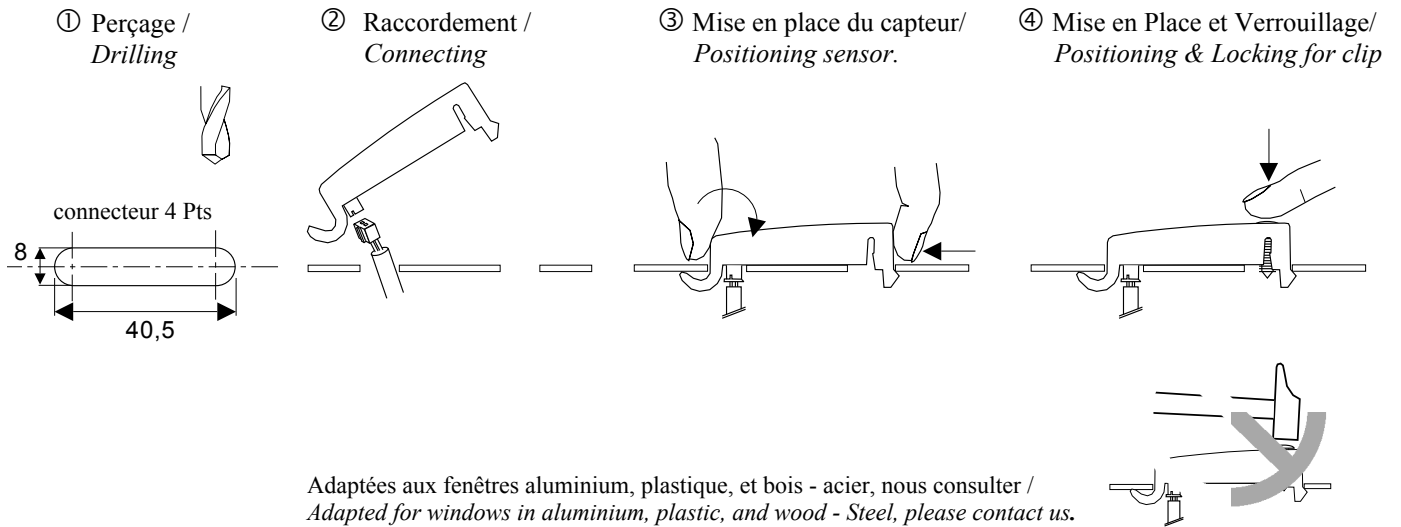

Distances de fonctionnement / Activation distances :

PW520000 (à clipser)
(to be clipped)



UZ189538 (à coller)
(to be glued)

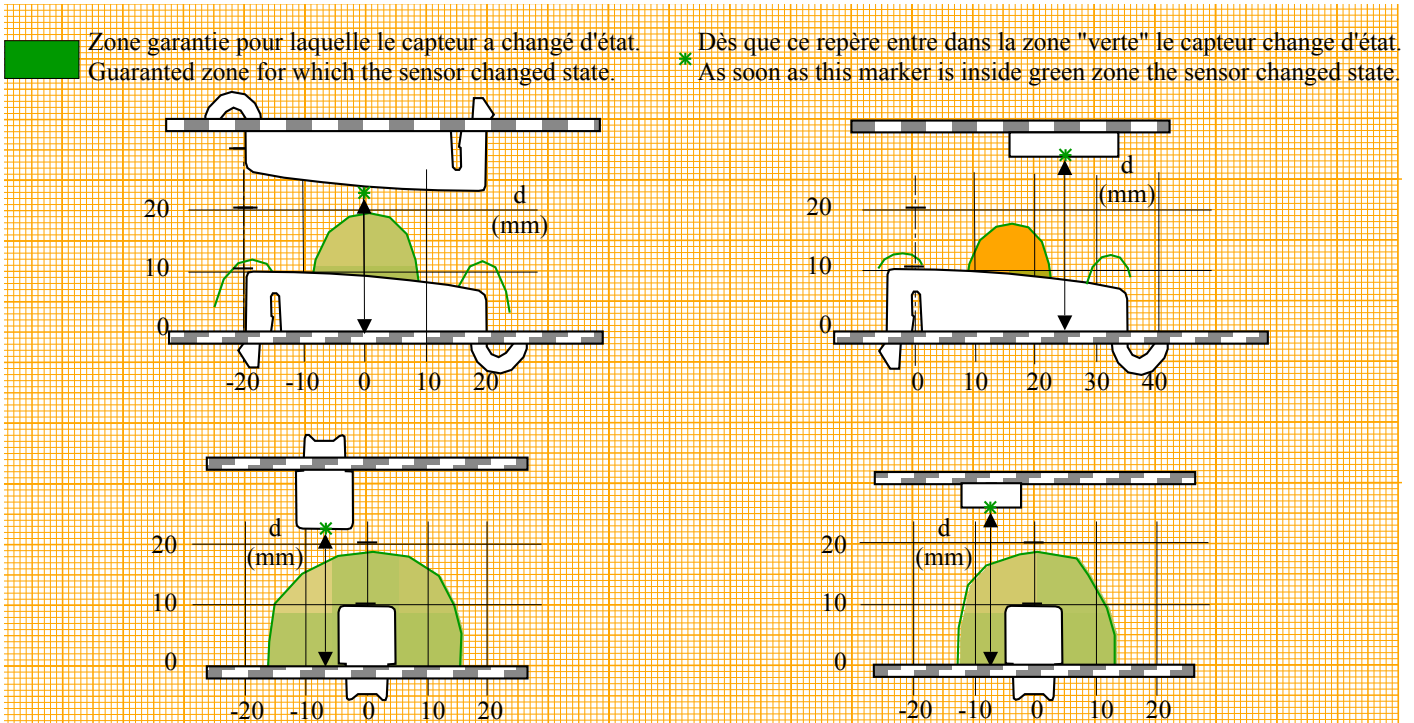

Proud to serve you

All technical characteristics are subject to change without previous notice.
Caractéristiques sujettes à modifications sans préavis.

celduc®
r e l a i s

Distances de fonctionnement / Activation distances :

**UR124540 (à visser)
(to be screwed)**



Vis/Screw M4 max

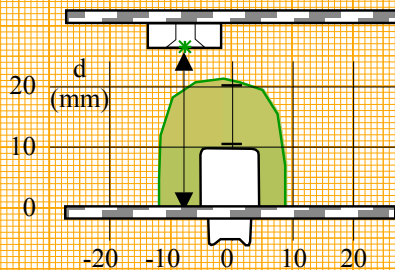
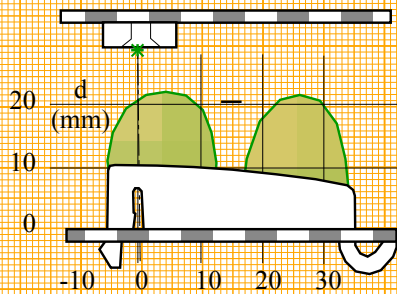

**UR144360 (à visser)
(to be screwed)**



Vis/Screw M4 max

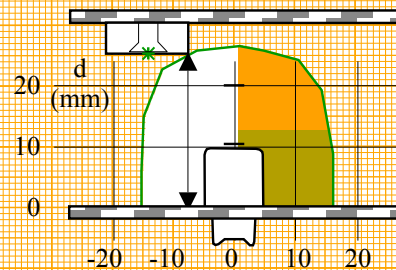
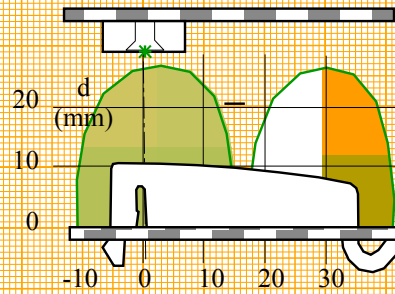

**UR102540 (à visser)
(to be screwed)**



vis Ø 2.5 max

