

MATERIALS:
 - TERMINAL- PhBz CuSn 8 (C521). TIN PRE-PLATED STOCK (0.15mm THICK)
 - HOUSING - STANYL (PA4.6) 30% G.F. VO BLACK COLOR

NOTES:
 PIN DIA : 0.45+/-0.01
 PCB THICKNESS: 0.8 / 1.2mm
 COPLANARITY OF THE SOLDER TAILS: 0.1mm
 INS. FORCE (0.46 GAUGE): 3.5N MAX/CIRCUIT
 W/D FORCE (0.44 GAUGE): 0.5N MIN/CIRCUIT

PACKAGING: SEE SHEET 2/2
 PRODUCT CHARACTERISTICS: ACCORDING TO PS-94123-007.

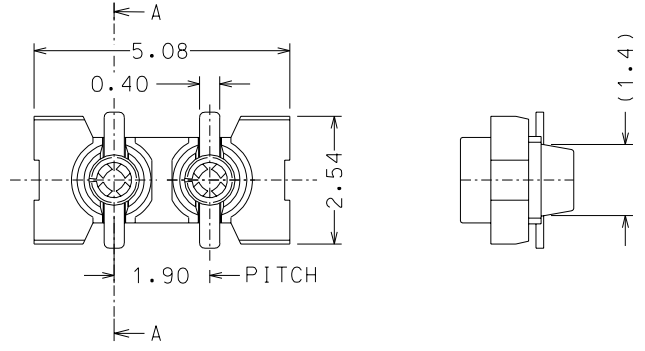
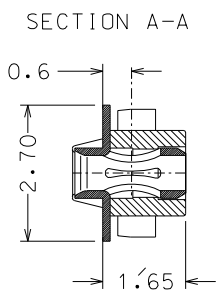

PROPOSED P.C. BOARD LAYOUTS

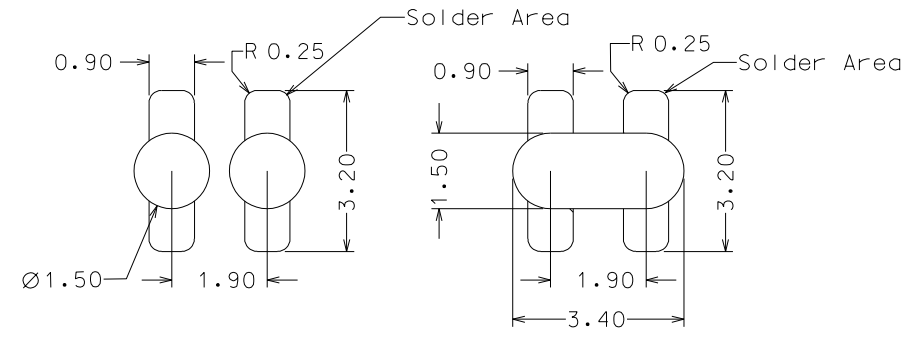

MTL NO°	PACKAGING
94123-6032	LOOSE IN BOX
94123-1032	TAPE & REEL

EC NO. Z2004-0226 DRW: GZJUN 04/04/30 CHK: RSANDANO 04/04/30 APPR: FBISIELLO 04/04/30	DESCRIPTION MAJOR SIGNIF. CRITICAL	QUALITY SYMBOLS	GENERAL TOLERANCES: (UNLESS SPECIFIED)	SCALE 10:1	DESIGN UNITS <input checked="" type="checkbox"/> mm <input type="checkbox"/> INCH	DIMENSIONS: <input type="checkbox"/> mm <input type="checkbox"/> INCH <input checked="" type="checkbox"/> mm ONLY	SHT	REV
		MAJOR M = 1	mm	INCH	DRAWN BY & DATE G. ZUIN 03/12/19	FIRST ANGLE PROJECTION	REVISE ON CAD ONLY	
3	REV	SIGNIF. S = 1	4 PLACES ±0.1	±.	CHECKED BY & DATE RSANDANO 03/12/19	TITLE: SMT SIP SOCKET BOTTOM ENTRY 2 CKT 1.9 PITCH "I" SHAPE	MATERIAL NO. SEE TABLE	DRAWING NO. SD-94123-007
		CRITICAL C =	3 PLACES ±0.05	±.	APPROVED BY & DATE FBISIELLO 03/12/19			
DRAFT WHERE APPLICABLE MUST REMAIN WITHIN DIMENSIONS			ANGULAR: ± 1°	CAD FILENAME	MOLEX INCORPORATED		SIZE A3	
THIS DRAWING CONTAINS INFORMATION THAT IS PROPRIETARY TO MOLEX INCORPORATED AND SHOULD NOT BE USED WITHOUT WRITTEN PERMISSION.								

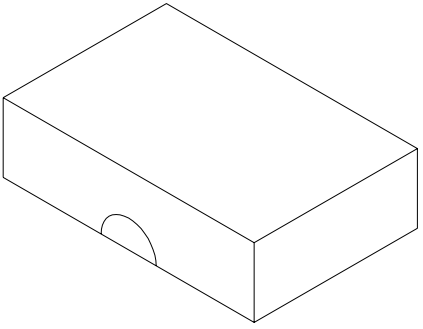
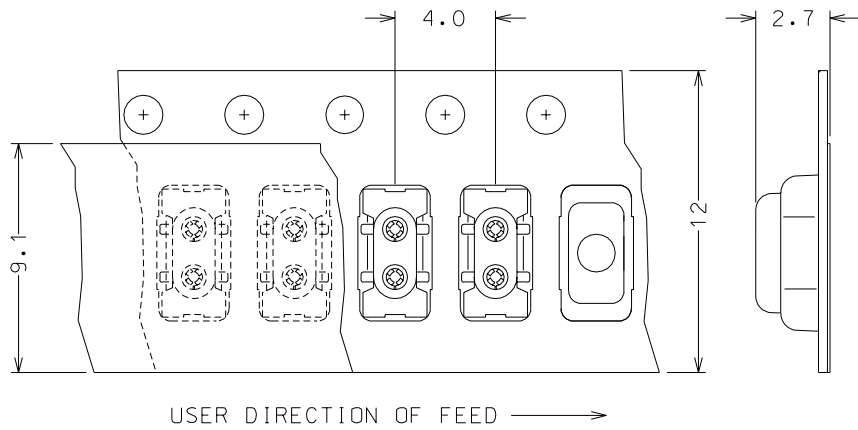

PACKAGING CONFIGURATION
TAPE & REEL PER EIA 481

NOTES:
EMBOSSED CARRIER 12 mm
(BLACK CONDUCTIVE POLYSTYRENE)
COVER TAPE 9.1 mm
(ANTI-STATIC POLYESTER FILM)
REEL DIA 330mm (NOT CONDUCTIVE
POLYSTYRENE)
EXTERNAL BOX DIM = 360X360X200 mm
N° OF PCS/REEL = 6 K
N° OF REELS/BOX = 8
N° OF PCS/BOX = 48 K
S.P.Q. = 48 K PCS

PACKAGING CONFIGURATION
LOOSE IN BOX

NOTES:
POLYESTER BAG
DIM = 130X170+20 mm
PRIMARY CARTON BOX
DIM = 200X130X55 mm
SHIPPING CARTON UNIT
DIM = 410X220X200 mm
N° OF PCS/BAG = 6 K
N° OF BAGS/BOX = 5
N° OF PCS/BOX = 30 K
S.P.Q. = 30 K

MTL NO°	PACKAGING
94123-6032	LOOSE IN BOX
94123-1032	TAPE & REEL

EC NO. Z2004-0220 DRWG:GZJUN 04/04/26 CHK: RSANDANO 04/04/26 APPR:FBISSELLO 04/04/26	QUALITY SYMBOLS MAJOR M = SIGNIF. S = CRITICAL C =	GENERAL TOLERANCES: (UNLESS SPECIFIED)		SCALE NOT	DESIGN UNITS <input checked="" type="checkbox"/> mm <input type="checkbox"/> INCH	DIMENSIONS: <input type="checkbox"/> mm <input type="checkbox"/> INCH <input checked="" type="checkbox"/> mm ONLY	SHT REV	
		4 PLACES ±0. ±.	DRAWN BY & DATE G.ZUIN 03/12/19	FIRST ANGLE PROJECTION		TITLE: SMT SIP SOCKET BOTTOM ENTRY 2 CKT 1.9 PITCH "I" SHAPE		REVISE ON CAD ONLY
		3 PLACES ±0. ±.	CHECKED BY & DATE RSANDANO 03/12/19	MOLEX INCORPORATED		MATERIAL NO. SEE TABLE	DRAWING NO. SD-94123-007	SHEET NO. 2 / 2
		2 PLACES ±0. ±.	APPROVED BY & DATE FBISSELLO 03/12/19	DRAFT WHERE APPLICABLE MUST REMAIN WITHIN DIMENSIONS		THIS DRAWING CONTAINS INFORMATION THAT IS PROPRIETARY TO MOLEX INCORPORATED AND SHOULD NOT BE USED WITHOUT WRITTEN PERMISSION.		SIZE A3
1 PLACE ±0. ±.	ANGULAR: ± °	CAD FILENAME .						