

AS1901, AS1902, AS1903

Ultra Low-Power μ P Supervisory Circuit

Data Sheet

1 General Description

The AS1901/2/3 family is an ultra low-power supervisory circuit device.

The device can be used to monitor the supply voltage of digital systems and microprocessors and initiate a reset when the voltage goes below a predefined threshold. The duration of the reset is 5/20/100/500ms (typ.) after the supply voltage has risen above the threshold.

The AS1901/2/3 exhibit excellent reliability and can reduce application costs by eliminating all external components.

The device is available with different output drivers:

- The AS1901 has a push-pull driver with an active low reset.
- The AS1902 uses the same output stage as the AS1901, but has an active high reset.
- The AS1903 has an open drain output with active low reset.

All devices operate down to a voltage of 1V.

The reset thresholds are factory-trimmable between 2.2V and 3.08V in steps of approximately 100mV.

Each device of the AS1901/2/3 family is offered with four time-out periods of 5/20/100/500ms.

The extremely low current consumption of only 230nA (typ) at 3.3V makes the device ideal for use in portable applications.

All devices are available in a 3-pin SOT23 package.

2 Key Features

- Low 230nA (typ) Supply Current
- Precision Monitoring of 2.5-, 3-, and 3.3V-Power Supplies
- Supply Voltage Range: 1.0 to 3.6V
- Reset Threshold Range: 2.2 to 3.1V
- Available in 3 Versions:
 - AS1901 Push Pull RESETN
 - AS1902 Push Pull RESET
 - AS1903 Open Drain RESETN
- 4 Time-Out Periods Ranging from 5 to 500ms
- Detection Voltage Accuracy: $\pm 1.5\%$
- Temperature Range: -40 to +85°C
- Package: SOT23-3

3 Applications

The devices are ideal for computers, intelligent instruments, controllers, critical microprocessor and micro-controller, power monitoring and portable/battery-powered equipment.

Figure 1. Functional Block Diagrams

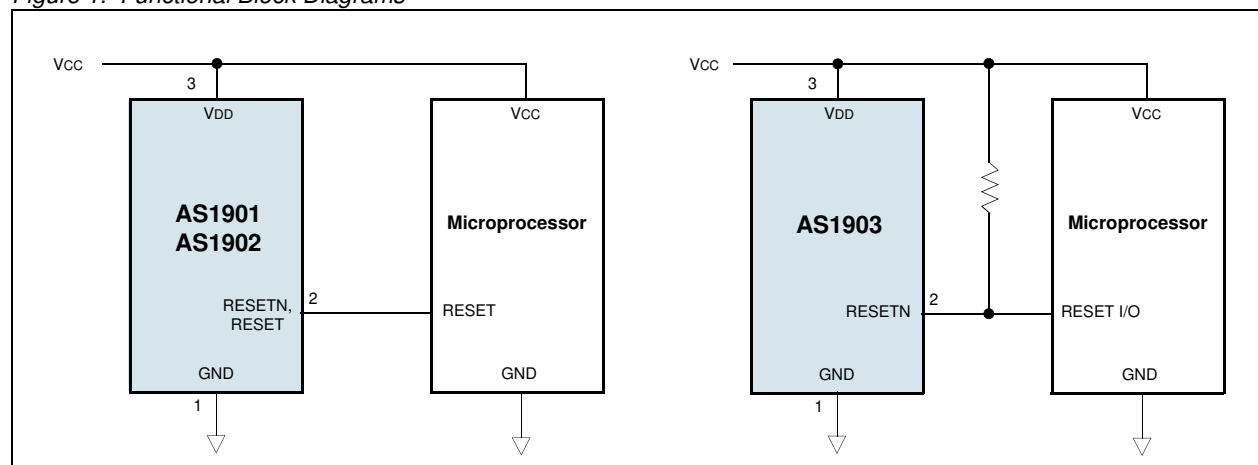

4 Pinout

Pin Assignments

Figure 2. Pin Assignments (Top View)

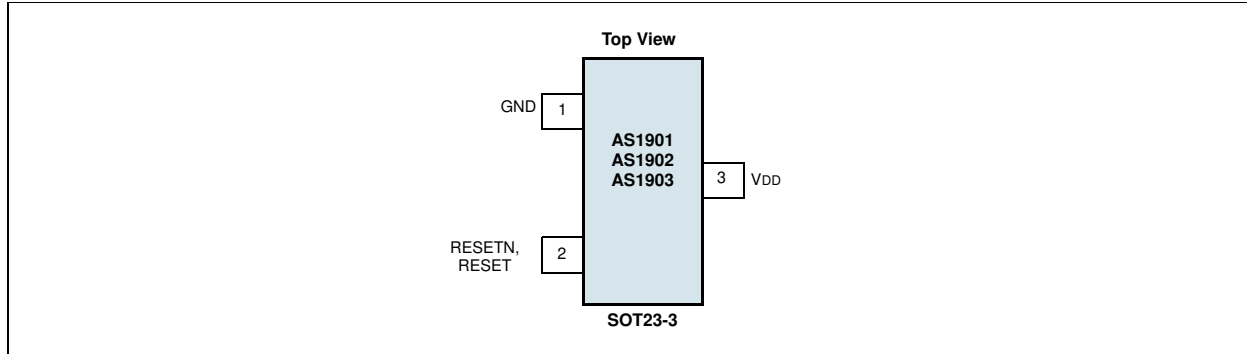

Pin Descriptions

Table 1. Pin Descriptions

Pin Number		Pin Name	Description
AS1901/AS1903	AS1902		
1	1	GND	Ground
2	-	RESETN	Active-low reset output. RESETN remains low while VDD is below the reset threshold and for tTP after VDD rises above the reset threshold. RESETN is open-drain on the AS1903 and push-pull on the AS1901.
-	2	RESET	Active-high reset output. RESET remains high while VDD is below the reset threshold and for tTP after VDD rises above the reset threshold.
3	3	VDD	Supply voltage.

5 Absolute Maximum Ratings

Stresses beyond those listed in Table 2 may cause permanent damage to the device. These are stress ratings only, and functional operation of the device at these or any other conditions beyond those indicated in Section 6 Electrical Characteristics is not implied. Exposure to absolute maximum rating conditions for extended periods may affect device reliability.

Table 2. Absolute Maximum Ratings ($T_A = 25^\circ\text{C}$ Unless Otherwise Noted)

Parameter	Limits	Unit	Notes
VDD to GND	-0.3 to +5	V	
RESET/RESETN to GND	-0.3 to VDD + 0.3	V	
Input Current (VDD)	20	mA	
Output Current (RESET, RESETN)	20	mA	
Rate of Rise (VDD)	100	V/ μs	
Operating Temperature Range (T_A)	-40 to +85	$^\circ\text{C}$	
Storage Temperature Range	-65 to +150	$^\circ\text{C}$	
Package-Body Peak Temperature	+260	$^\circ\text{C}$	The reflow peak soldering temperature (body temperature) specified is in accordance with IPC/JEDEC J-STD-020C "Moisture/Reflow Sensitivity Classification for non-hermetic Solid State Surface Mount Devices"

6 Electrical Characteristics

V_{DD} = Full Range; T_A = -40 to +85°C; Unless Otherwise Specified

Table 3. Electrical Characteristics

Parameter	Symbol	Conditions	Min	Typ	Max	Unit
V _{DD} Range	V _{DD}	$T_A = 0$ to +70°C	1.0		3.6	V
		$T_A = -40$ to +85°C	1.2		3.6	
Supply Current (AS1901/2/3)	I _{DD}	V _{DD} = 3.3V, No Load		230	430	nA
Reset Threshold Voltage ¹	V _{TH}	$T_A = +25^\circ\text{C}$	V _{TH} - 1.5%	V _{TH}	V _{TH} + 1.5%	V
		$T_A = -40$ to +85°C	V _{TH} - 2.5%	V _{TH}	V _{TH} + 2.5%	
V _{DD} to Reset Delay ²	t _{RD}	V _{DD} = V _{TH} to (V _{TH} - 100mV)		20	50	μs
Reset Active Time-Out Period ³	t _{TP}		t _{TP} - 40%	t _{TP}	t _{TP} + 60%	ms
RESETN Output Voltage (AS1901/3)	V _{OL}	I _{SINK} = 1.2mA, V _{DD} = 2.1V, Reset Asserted			0.4	V
		I _{SINK} = 400μA, V _{DD} = 1.2V, Reset Asserted			0.4	V
RESETN Output Voltage (AS1901)	V _{OH}	I _{SOURCE} = 1.2mA, V _{DD} = 3.2V	0.8 x V _{DD}			V
RESET Output Voltage (AS1902)	V _{OH}	I _{SOURCE} = 500μA, V _{DD} = 2.1V, Reset Asserted	0.8 x V _{DD}			V
		I _{SOURCE} = 100μA, V _{DD} = 1.2V, Reset Asserted	0.8 x V _{DD}			V
	V _{OL}	I _{SINK} = 1.2mA, V _{DD} = 3.2V, Reset Not Asserted			0.4	V
RESET Threshold Hysteresis	V _{HYST}			10		mV
Open-Drain RESETN Output Leakage Current (AS1903)	I _{LEAK}				0.1	μA

Notes:

¹ See Table 6, "Coding of Factory-Trimmed Reset Threshold Voltages," on page 6.

² Guaranteed by design.

³ See Table 4, "Coding of Factory-trimmed Reset Active Time-Out Period," on page 6.

7 Typical Operating Characteristics

Figure 3. Supply Current vs. Temperature

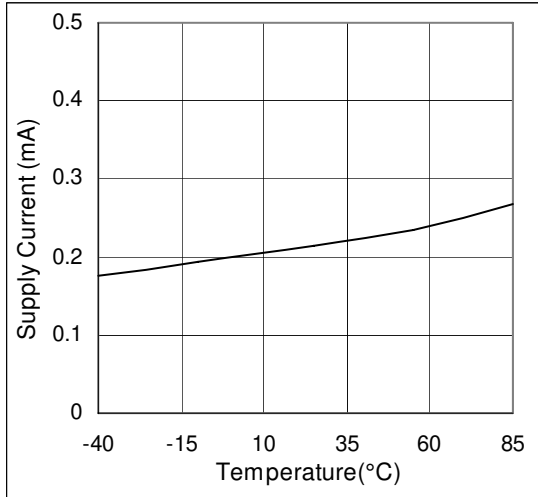

Figure 4. Power Down Reset Delay vs. Temp.

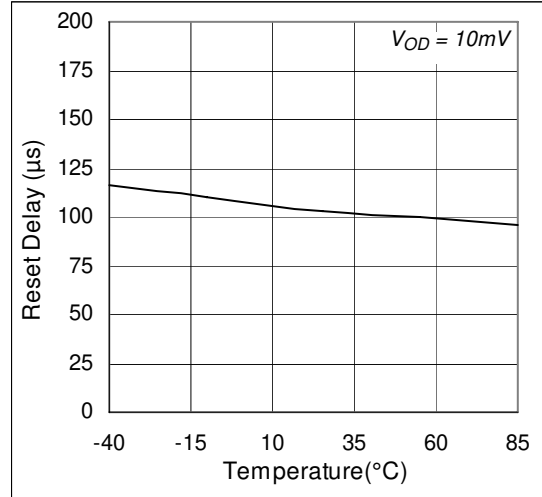

Figure 5. Power-Up Reset Timeout vs. Temperature

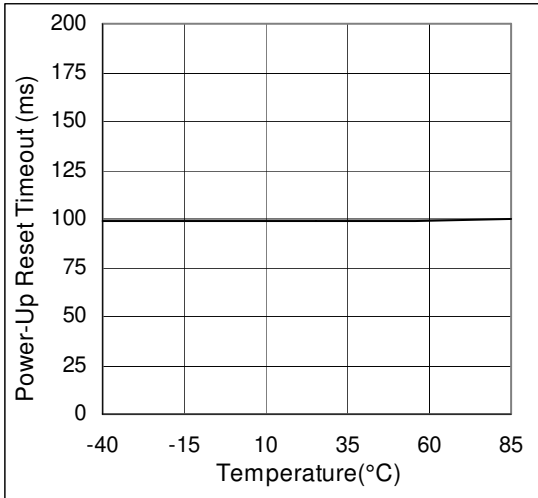
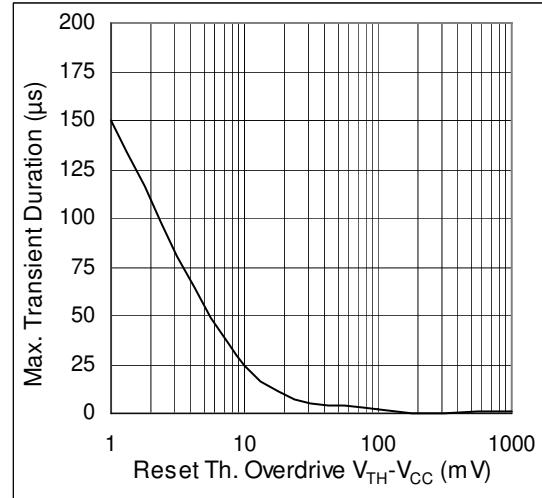

Figure 6. Max. Trans. Duration vs. Reset Th. Overdrive



8 Detailed Description

Interfacing to Microprocessors with Bi-Directional Reset Pins

The device has an open drain RESETN output, which enables easy interfacing to microprocessors (μP) with bi-directional reset pins, such as the Motorola 68HC11. The RESETN pin of the microcontroller (μC) can be connected directly to the μP supervisor's RESETN output with a single pull-up resistor (see Figure 1 on page 1).

Negative-Going VDD Transients

The device is optimized to ignore short-duration, negative-going VDD transients (glitches) in order to avoid incorrect resets.

In the graph Maximum Transient Duration vs. Reset Threshold Overdrive (page 6), the conditions are shown, for which the reset pulses are not generated. In the graph the maximum pulse width that a negative VDD transient may have when a reset signal is generated. As the amplitude of the transient increases, the maximum allowable pulse width decreases.

Options

Table 4. Coding of Factory-trimmed Reset Active Time-Out Period

Device	Suffix	tTP in Milliseconds		
		Min	Typ	Max
AS190x_xx	A	3	5	8
AS190x_xx	B	12	20	32
AS190x_xx	C	60	100	160
AS190x_xx	D	300	500	800

Table 5. Output Variants

Device	Output Functionality
AS1901xxx	Active Low (RESETN)
AS1902xxx	Active High (RESET)
AS1903xxx	Open Drain (RESETN)

Table 6. Coding of Factory-Trimmed Reset Threshold Voltages

Device	Suffix	Reset Threshold Voltage, V_{TH} in V				
		$T_{\text{A}} = +25^{\circ}\text{C}$			$T_{\text{A}} = -40 \text{ to } +85^{\circ}\text{C}$	
		Min	Typ	Max	Min	Max
AS190xx__	22	2.167	2.2	2.233	2.145	2.255
AS190xx__	23	2.285	2.32	2.355	2.262	2.378
AS190xx__	24	2.364	2.4	2.436	2.340	2.460
AS190xx__	25	2.463	2.5	2.538	2.438	2.563
AS190xx__	26	2.591	2.63	2.669	2.564	2.696
AS190xx__	27	2.660	2.7	2.741	2.633	2.768
AS190xx__	28	2.758	2.8	2.842	2.730	2.870
AS190xx__	29	2.886	2.93	2.974	2.857	3.003
AS190xx__	30	2.955	3.0	3.045	2.925	3.075
AS190xx__	31	3.034	3.08	3.126	3.003	3.157

9 Package Drawings and Markings

The device is available in a 3-pin SOT-23 package.

Figure 7. 3-Pin SOT-23 Package.

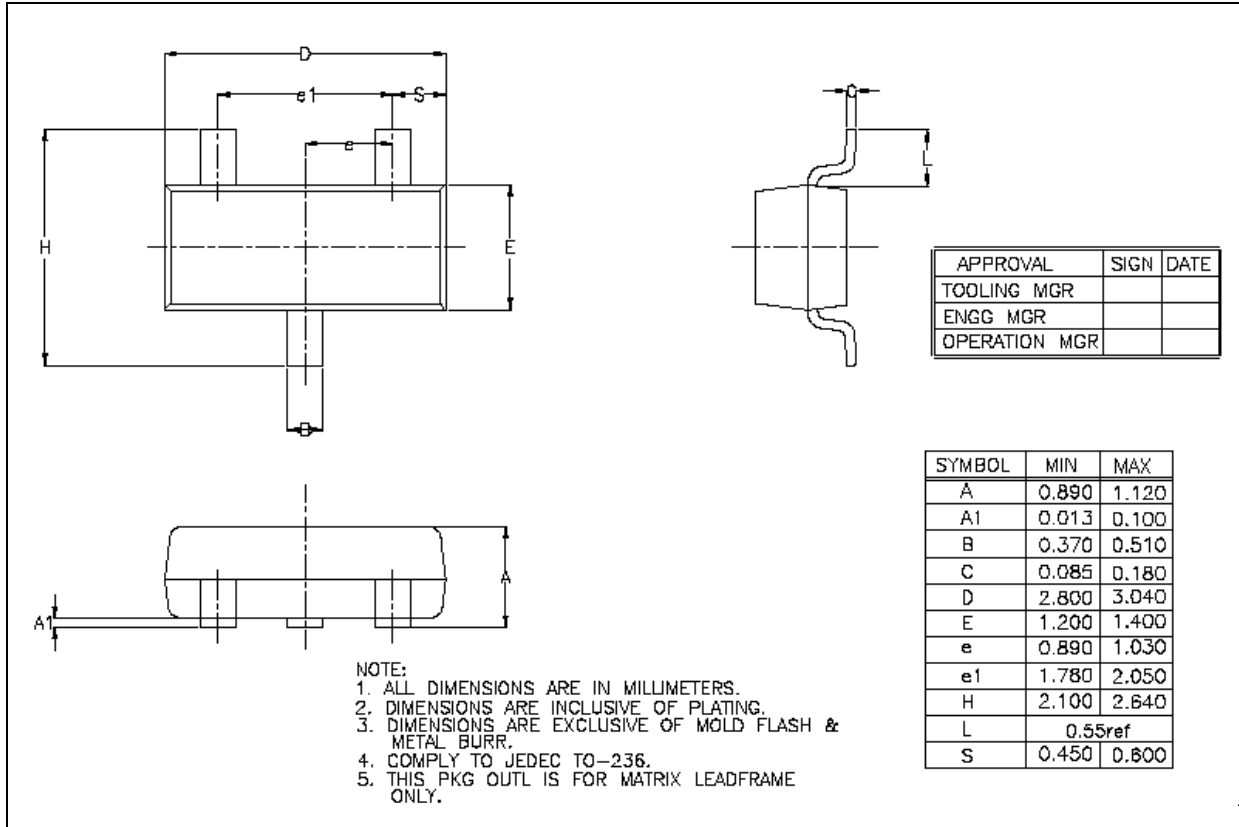

10 Ordering Information

The device is available in the following standard versions.

Standard Part	Threshold	Duration	Marking
AS1901C23	2.32	100ms	ASBA
AS1901C26	2.63	100ms	ASBD
AS1901C31	3.08	100ms	ASBI
AS1902C23	2.32	100ms	ASBK
AS1902C26	2.63	100ms	ASBN
AS1902C31	3.08	100ms	ASBS
AS1903C23	2.32	100ms	ASBU
AS1903C26	2.63	100ms	ASBX
AS1903C31	3.08	100ms	ASB3

Non-standard versions require a minimum order of 30,000 units. Contact austriamicrosystems for availability of non-standard versions.

Copyrights

Copyright © 1997-2007, austriamicrosystems AG, Schloss Premstaetten, 8141 Unterpremstaetten, Austria-Europe. Trademarks Registered ®. All rights reserved. The material herein may not be reproduced, adapted, merged, translated, stored, or used without the prior written consent of the copyright owner.

All products and companies mentioned are trademarks or registered trademarks of their respective companies.

Disclaimer

Devices sold by austriamicrosystems AG are covered by the warranty and patent indemnification provisions appearing in its Term of Sale. austriamicrosystems AG makes no warranty, express, statutory, implied, or by description regarding the information set forth herein or regarding the freedom of the described devices from patent infringement. austriamicrosystems AG reserves the right to change specifications and prices at any time and without notice. Therefore, prior to designing this product into a system, it is necessary to check with austriamicrosystems AG for current information. This product is intended for use in normal commercial applications. Applications requiring extended temperature range, unusual environmental requirements, or high reliability applications, such as military, medical life-support or life-sustaining equipment are specifically not recommended without additional processing by austriamicrosystems AG for each application. For shipments of less than 100 parts the manufacturing flow might show deviations from the standard production flow, such as test flow or test location.

The information furnished here by austriamicrosystems AG is believed to be correct and accurate. However, austriamicrosystems AG shall not be liable to recipient or any third party for any damages, including but not limited to personal injury, property damage, loss of profits, loss of use, interruption of business or indirect, special, incidental or consequential damages, of any kind, in connection with or arising out of the furnishing, performance or use of the technical data herein. No obligation or liability to recipient or any third party shall arise or flow out of austriamicrosystems AG rendering of technical or other services.



Contact Information

Headquarters

austriamicrosystems AG
A-8141 Schloss Premstaetten, Austria

Tel: +43 (0) 3136 500 0
Fax: +43 (0) 3136 525 01

For Sales Offices, Distributors and Representatives, please visit:

<http://www.austriamicrosystems.com/contact>