

DESCRIPTION

The LX432 series are low-voltage precision adjustable shunt regulators with a reference voltage of 1.24V. The output voltage may be set to any value between 1.24V and 20V by two external resistors.

These devices offer low output impedance for improved load regulation – typical output impedance is 200mΩ. The LX432 series operates with an operating current as low as 80μA, making these devices suitable for portable and micropower applications.

Low voltage operation enables the LX432 to be used in the feedback loop of isolated low voltage power supplies. The minimum output voltage is determined by the LX432 output voltage plus the forward voltage drop of the opto-coupler LED (typically 1.24 + 1.4 = 2.64V minimum). See figure 12.

The LX432 is offered in 3 and 5-Pin SOT-23 or TO-92 packages, and is a drop-in replacement for the TLV431 and SC431L devices.

IMPORTANT: For the most current data, consult MICROSEMI's website: <http://www.microsemi.com>

KEY FEATURES

- Low Voltage Operation: 1.24V Reference
- Initial Voltage Reference Accuracy 1%
- Adjustable Output Voltage From VREF to 20V
- Typical Output Dynamic Impedance Less Than 250mΩ
- Sink Current Capability 80μA To 20mA
- Direct Alternative To TLV431

APPLICATIONS

- Low Voltage Adjustable Power Supplies
- Instrumentation
- Computers
- Portable Equipment

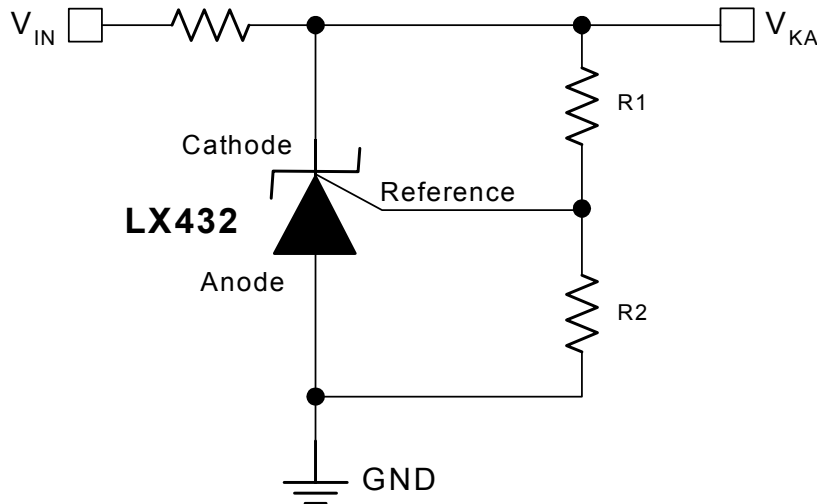
PRODUCT HIGHLIGHT

PACKAGE ORDER INFO

T _A (°C)	SC / SE Package Marking	SC	Plastic SOT-23 3-Pin	SE	Plastic SOT-23 5-Pin	LP	Plastic TO-92 3-Pin
0 to 70	432C		LX432CSC		LX432CSE		LX432CLP
-40 to 85	432I		LX432ISC		LX432ISE		LX432ILP

Note: Available in Tape & Reel.
Append the letters "TR" to the part number. (i.e. LX432CSE-TR)
TO-92 (LP) package also available in ammo-pack.

ABSOLUTE MAXIMUM RATINGS (NOTE 1)

Cathode to Anode Voltage (V_{KA}).....	-0.3V to +20V
Reference Input Current (I_{REF}).....	-50 μ A to 10 μ A
Continuous Cathode Current (I_K).....	-25mA to 25mA
Operating Junction Temperature.....	150°C
Storage Temperature.....	-65°C to 150°C
Lead Temperature.....	300°C

Note 1: Exceeding these ratings could cause damage to the device. All voltages are with respect to Ground. Currents are positive into, negative out of specified terminal.

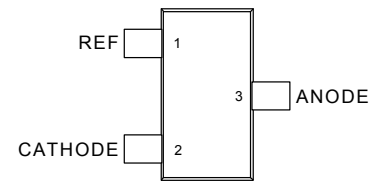
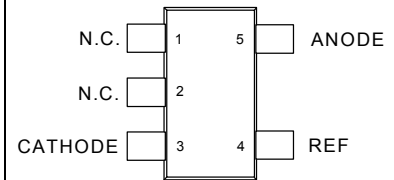
PACKAGE PIN OUT

SC PACKAGE – 3-PIN

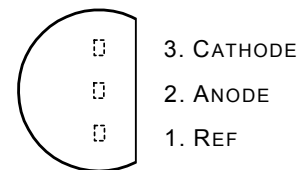
N.C. - No Internal Connection

SE PACKAGE – 5-PIN

LP PACKAGE – 3-PIN

(All Views Top View)

THERMAL DATA
SC 3-Pin Plastic Package

Thermal Resistance – Junction to Ambient, θ_{JA}	(PC Mounted)	220°C/W
	(Non-PC Mounted)	410°C/W

SE 5-Pin Plastic Package

Thermal Resistance – Junction to Ambient, θ_{JA}	(PC Mounted)	220°C/W
	(Non-PC Mounted)	410°C/W

LP 3-Pin Plastic Package

Thermal Resistance – Junction to Ambient, θ_{JA}	156°C/W
---	---------

Junction Temperature Calculation: $T_J = T_A + (P_D \times \theta_{JA})$.

The θ_{JA} numbers are guidelines for the thermal performance of the device/pc-board system. All of the above assume no ambient airflow.

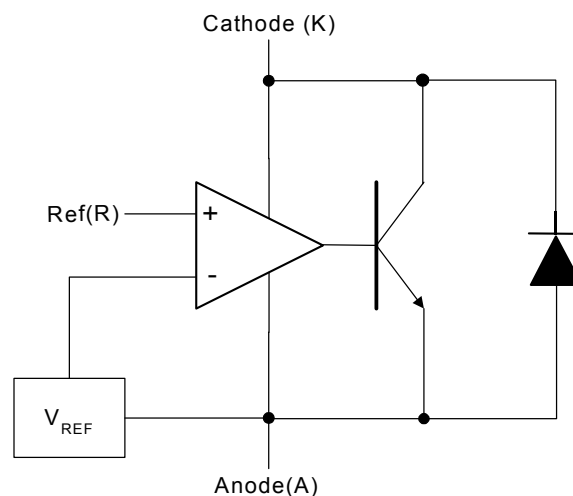
BLOCK DIAGRAM

Figure 1 – Simplified Block Diagram

ELECTRICAL CHARACTERISTICS

Unless otherwise specified, the following specifications apply over the operating ambient temperature for the LX432C with $0^{\circ}\text{C} \leq T_A \leq 70^{\circ}\text{C}$ and the LX432I with $-40^{\circ}\text{C} \leq T_A \leq 85^{\circ}\text{C}$ except where otherwise noted.

Parameter	Symbol	Test Conditions	LX432			Units
			Min	Typ	Max	
Reference Voltage	V_{REF}	$I_K = 10\text{mA}, V_{KA} = V_{REF}, T_A = 25^{\circ}\text{C}$	1.228	1.24	1.252	V
Reference Voltage Drift (note 2)	ΔV_{REF}	$I_K = 10\text{mA}, V_{KA} = V_{REF}, 0^{\circ}\text{C} \leq T_A \leq 70^{\circ}\text{C}$		3	12	mV
		$I_K = 10\text{mA}, V_{KA} = V_{REF}, -40^{\circ}\text{C} \leq T_A \leq 85^{\circ}\text{C}$		4	20	mV
Ratio of V_{REF} Change In Cathode Voltage Change (note 3)	$\frac{\Delta V_{REF}}{\Delta V_{KA}}$	$I_K = 10\text{mA}, V_{KA} = V_{REF} \text{ to } 16\text{V}, T_A = 25^{\circ}\text{C}$		-1	-2.7	mV/V
Reference Terminal Current	I_{REF}	$I_K = 10\text{mA}, V_{KA} = V_{REF}, T_A = 25^{\circ}\text{C}, R1=10\text{k}\Omega, R2=\text{Open}$		0.1	0.5	μA
Reference Current Drift (note 2)	ΔI_{REF}	$I_K = 10\text{mA}, V_{KA} = V_{REF}, 0^{\circ}\text{C} \leq T_A \leq 70^{\circ}\text{C}$		0.05	0.3	μA
		$I_K = 10\text{mA}, V_{KA} = V_{REF}, -40^{\circ}\text{C} \leq T_A \leq 85^{\circ}\text{C}$		0.1	0.4	μA
Minimum Cathode Current For Regulation	$I_{K(MIN)}$	$V_{KA} = V_{REF}, T_A = 25^{\circ}\text{C}$		55	80	μA
Dynamic Impedance	Z_{KA}	$I_K = 0.1\text{mA to } 15\text{mA}, V_{KA} = V_{REF}, T_A = 25^{\circ}\text{C}$		0.2	0.4	Ω
Off-State Cathode Current	I_{OFF}	$V_{KA} = 16\text{V}, T_A = 25^{\circ}\text{C}$		0.004		μA

Note 2: These parameters are guaranteed by design.

Note 3: $\frac{\Delta V_{REF}}{\Delta V_{KA}}$ Ratio of change in reference input voltage to the change in cathode voltage

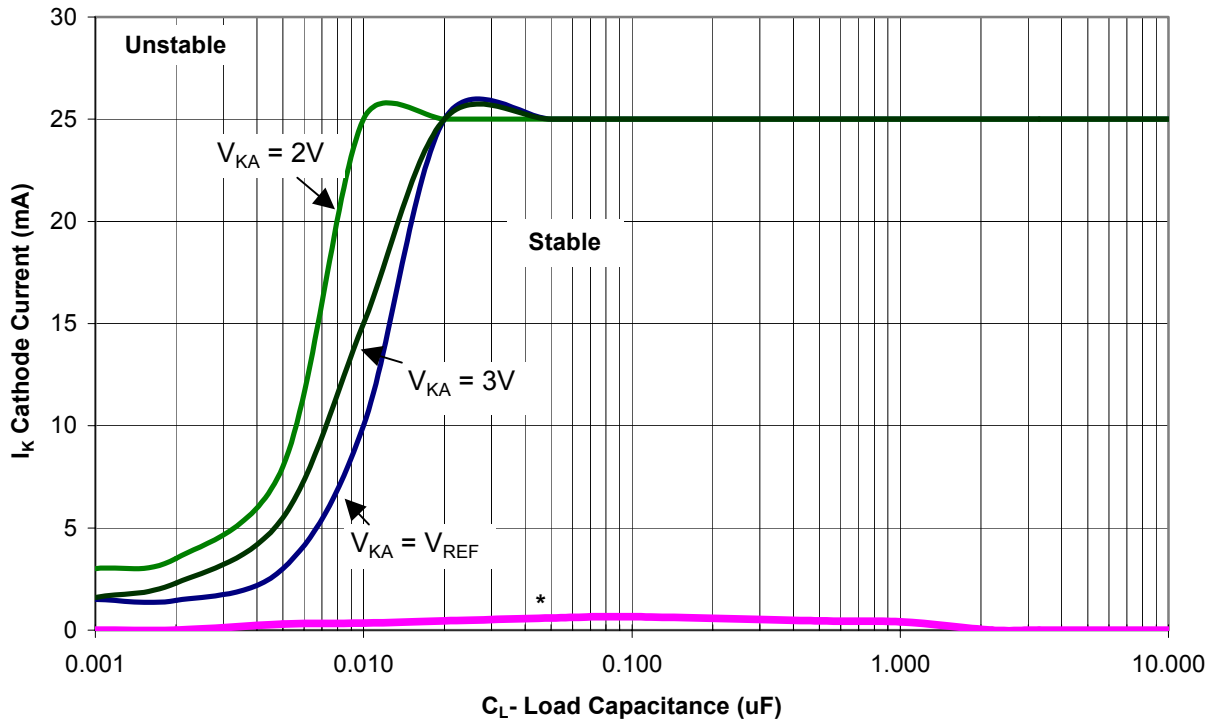
CHARACTERISTIC CURVES
STABILITY BOUNDARY CONDITION†

Figure 2 – Stability

* Unstable below 700 μA as indicated

† The unstable areas indicate loading conditions that may cause the device to oscillate.



CHARACTERISTIC CURVES

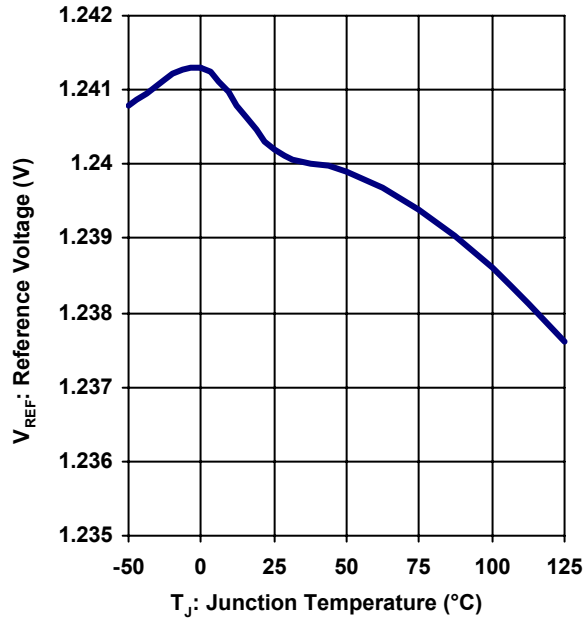

Figure 3 – Reference Voltage vs. Junction Temperature

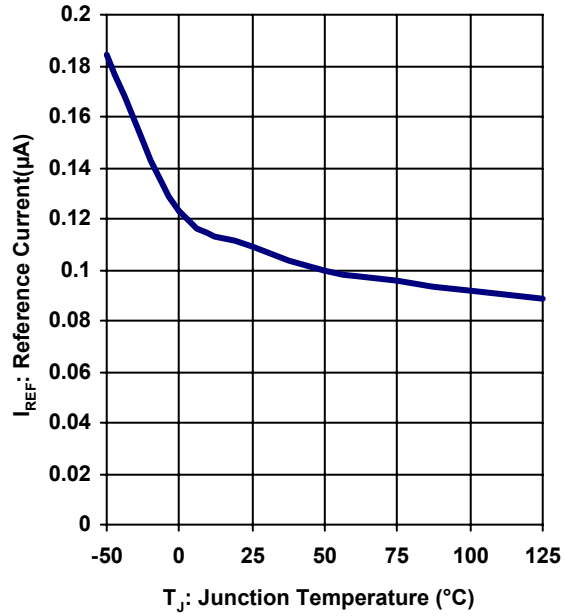

Figure 4 – Reference Current vs. Junction Temperature

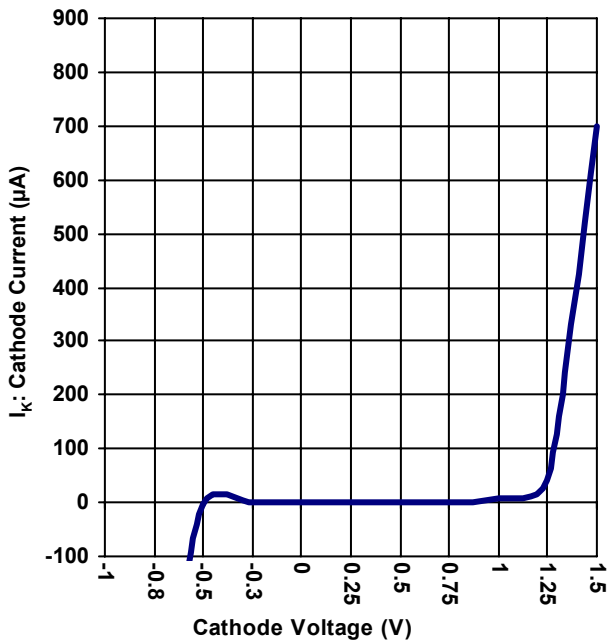

Figure 5 – Cathode Current vs. Cathode Voltage

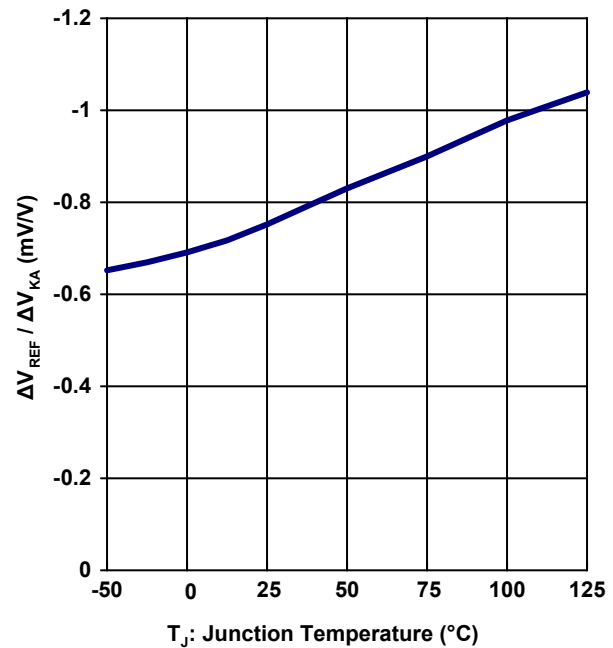
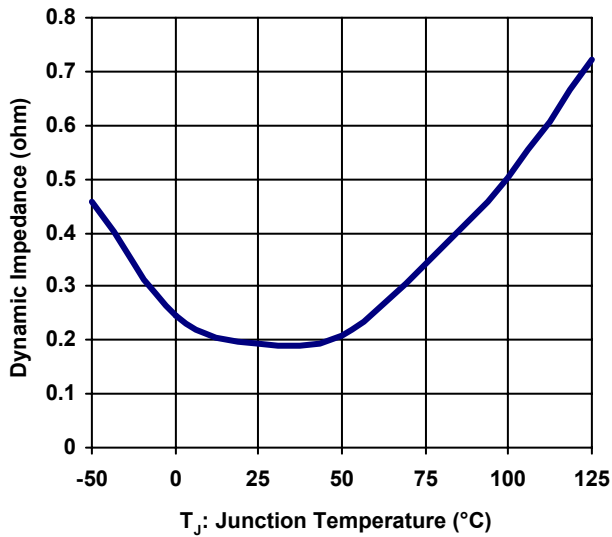
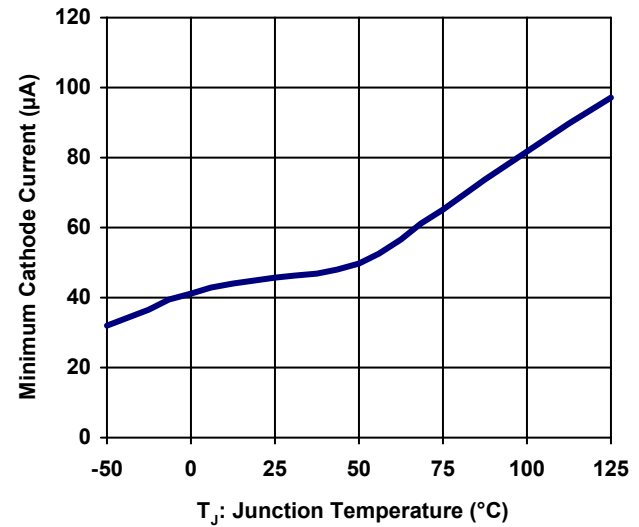
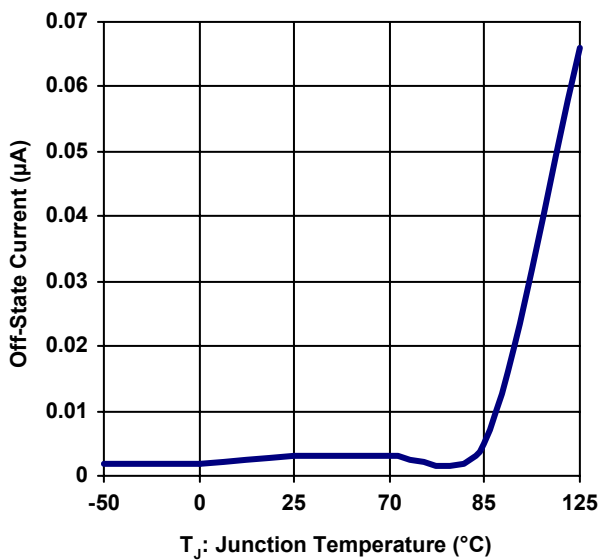
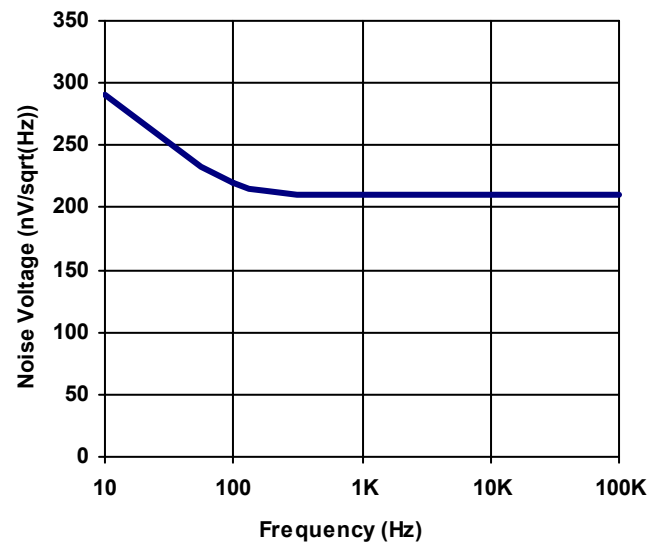
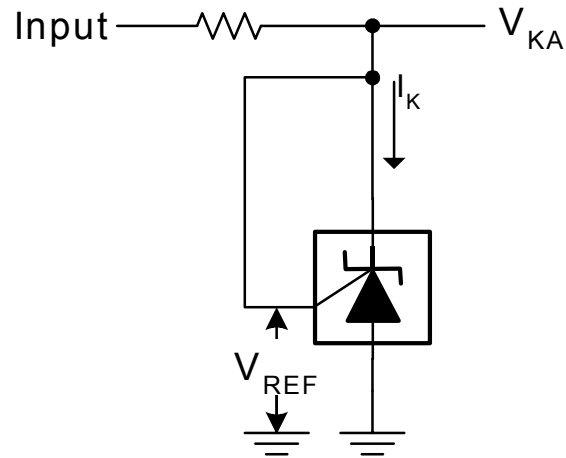
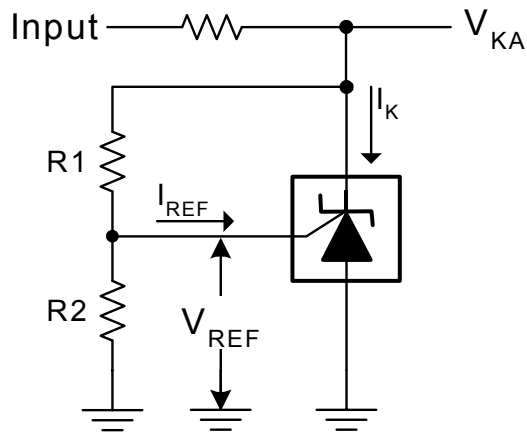
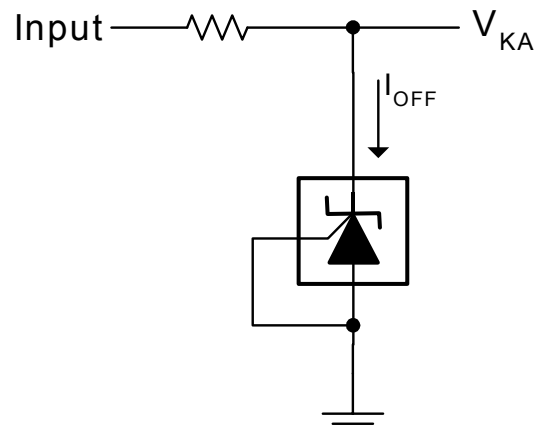
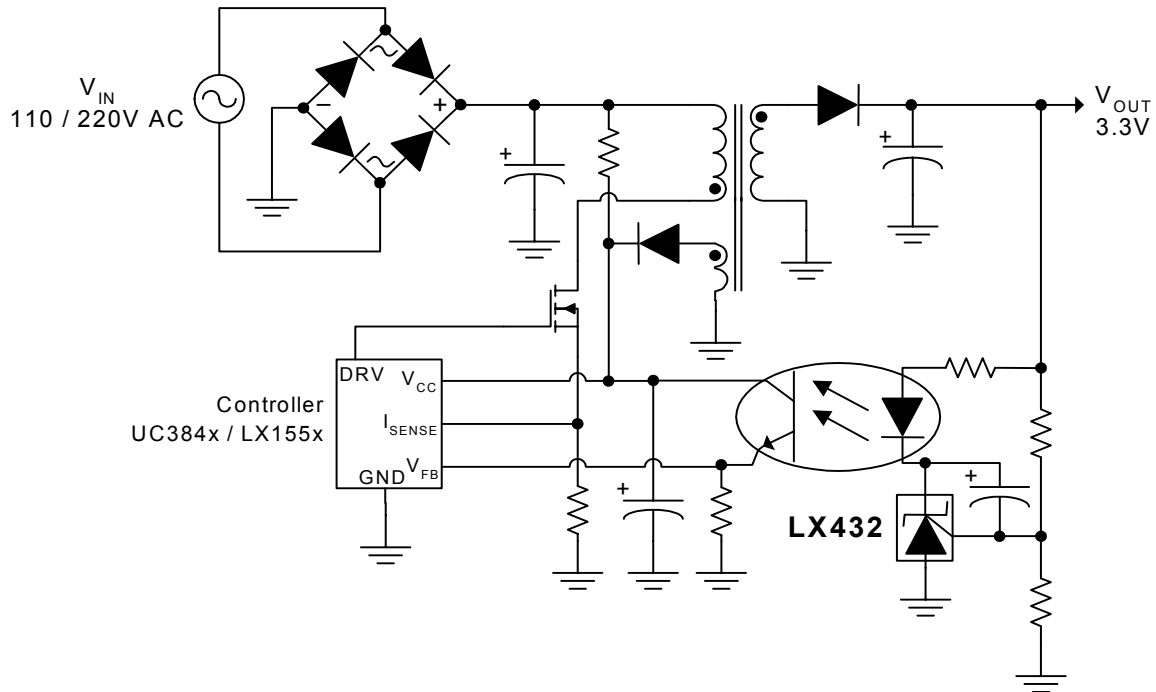
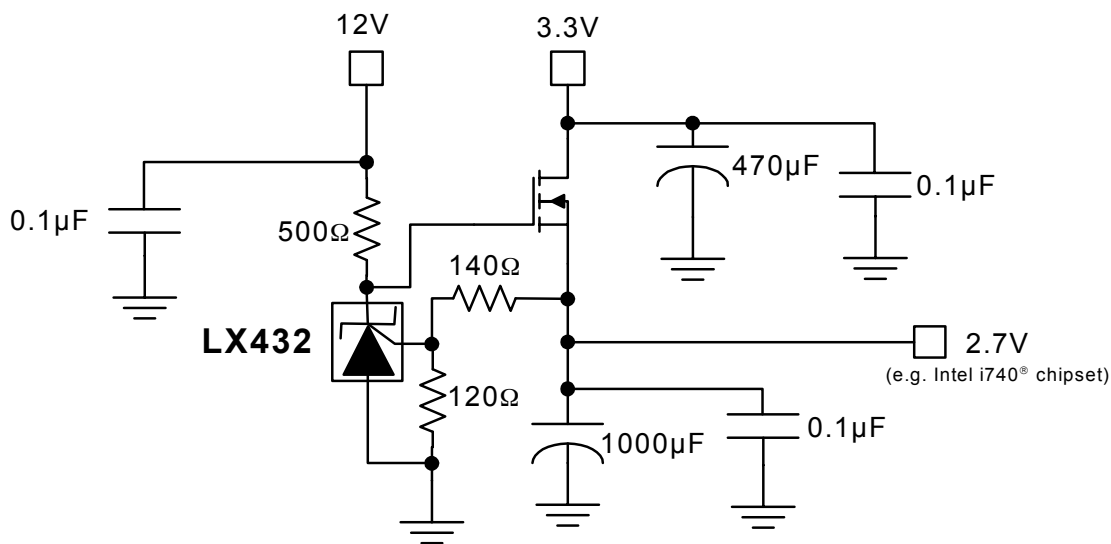

Figure 6 – $\Delta V_{REF} / \Delta V_{KA}$ vs. Junction Temperature

CHARACTERISTIC CURVES

Figure 7 – Dynamic Impedance vs. Junction Temperature

Figure 8 – Minimum Cathode Current for Regulation vs. Junction Temperature

Figure 9 – Off-State Current vs. Junction Temperature

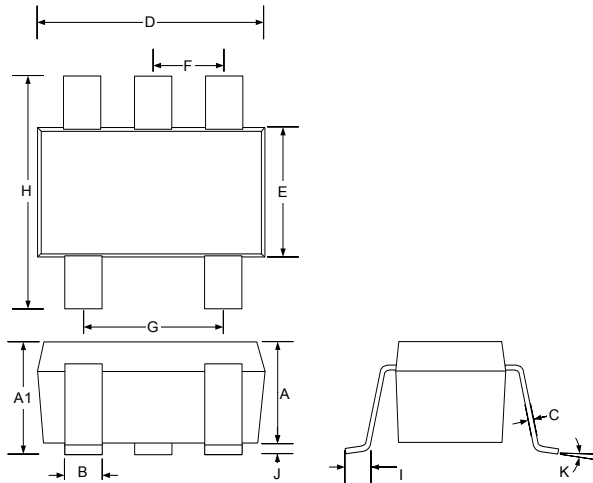
Figure 10 – Equivalent Input Noise Voltage vs. Frequency

PARAMETER MEASUREMENT INFORMATION

Figure 11 – Test Circuit For $V_{KA} = V_{REF}$

Figure 12 – Test Circuit For $V_{KA} > V_{REF}$

Figure 13 – Test Circuit For I_{OFF}

$$V_O = V_{KA} = V_{REF} \times \left(1 + \frac{R1}{R2} \right) + I_{REF} \times R1$$

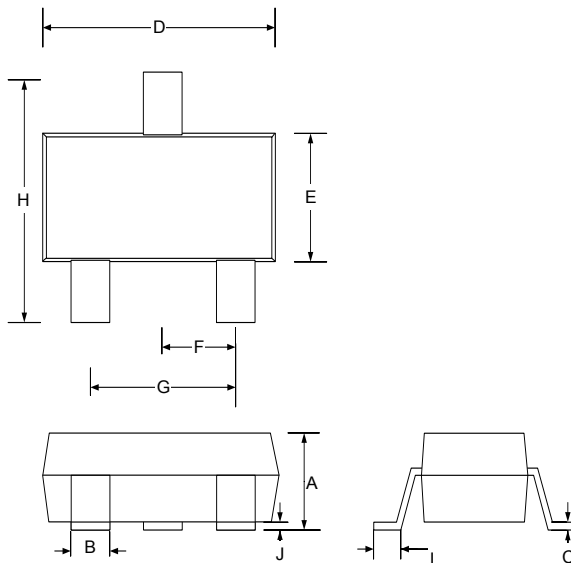
TYPICAL APPLICATION

Figure 12 – LX432 In A Power Supply Isolated Feedback Application

Figure 13 – LX432 in a 3.3V to 2.7V Low Dropout Regulator Application

PACKAGE DIMENSIONS
SE 5 Pin Plastic SOT-23

Dim	MILLIMETERS		INCHES	
	MIN	MAX	MIN	MAX
A	0.90	1.30	0.035	0.051
A1	0.90	1.45	0.035	0.057
B	0.25	0.50	0.010	0.020
C	0.09	0.20	0.004	0.008
D	2.80	3.10	0.110	0.122
E	1.50	1.75	0.059	0.069
F	0.95 BSC		0.038 BSC	
G	1.90 BSC		0.075 BSC	
H	2.60	3.00	0.102	0.118
I	0.35	0.55	0.014	0.022
J	0.00	0.15	0.000	0.006
K	10° MAX		10° MAX	

SC 3-Pin Plastic SOT-23

Dim	MILLIMETERS		INCHES	
	MIN	MAX	MIN	MAX
A	0.89	1.12	0.035	0.044
B	0.37	0.51	0.015	0.020
C	0.085	0.18	0.003	0.007
D	2.80	3.04	0.110	0.120
E	1.20	1.40	0.047	0.055
F	0.89	1.09	0.035	0.043
G	1.78	2.05	0.070	0.080
H	2.10	2.64	0.083	0.104
I	0.35	0.55	0.014	0.022
J	0.013	0.10	0.0005	0.0039

Note:

- Dimensions do not include mold flash or protrusions; these shall not exceed 0.155mm(.006") on any side. Lead dimension shall not include solder coverage.

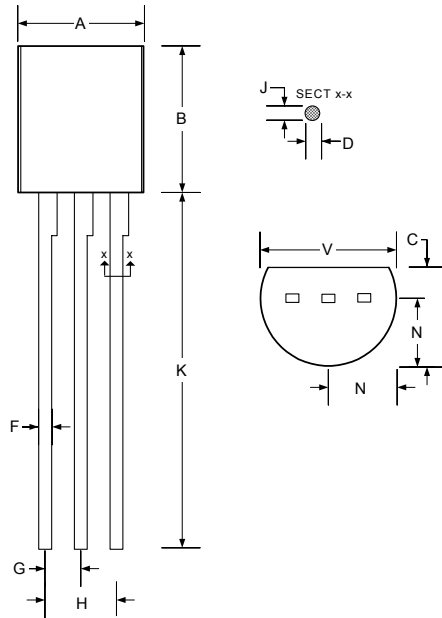
PACKAGE DIMENSIONS (CONTINUED)
LP 3-Pin Plastic TO-92

Dim	MILLIMETERS		INCHES	
	MIN	MAX	MIN	MAX
A	4.45	5.20	0.175	0.205
B	4.32	5.33	0.170	0.210
C	3.18	4.19	0.125	0.165
D	0.41	0.55	0.016	0.022
F	0.41	0.48	0.016	0.019
G	1.15	1.39	0.045	0.055
H	2.42	2.66	0.095	0.105
J	0.39	0.50	0.015	0.020
K	12.70	-	0.500	-
N	2.05	2.66	0.080	0.105
V	3.43	-	0.135	-

Note:

1. Dimensions do not include mold flash or protrusions; these shall not exceed 0.155mm(.006") on any side. Lead dimension shall not include solder coverage.



Microsemi[®]

LX432

Low Voltage Adjustable Precision Shunt Regulator

PRODUCTION DATA SHEET

NOTES

PRODUCTION DATA – Information contained in this document is proprietary to LinFinity and is current as of publication date. This document may not be modified in any way without the express written consent of LinFinity. Product processing does not necessarily include testing of all parameters. LinFinity reserves the right to change the configuration and performance of the product and to discontinue product at any time.