

PART NUMBER	ENGINEERING NO.	LENGTH
1300080096	301001A01F030	3'-0" +2.19 - 0 [.9M +55.6 - 0]
1300080098	301001A01F060	6'-0" +3.50 - 0 [1.8M +88.9 - 0]
1300080100	301001A01F120	12'-0" +6.50 - 0 [3.7M +165.1 - 0]
1300080104	301001A01F200	20'-0" +6.50 - 0 [6.1M +165.1 - 0]

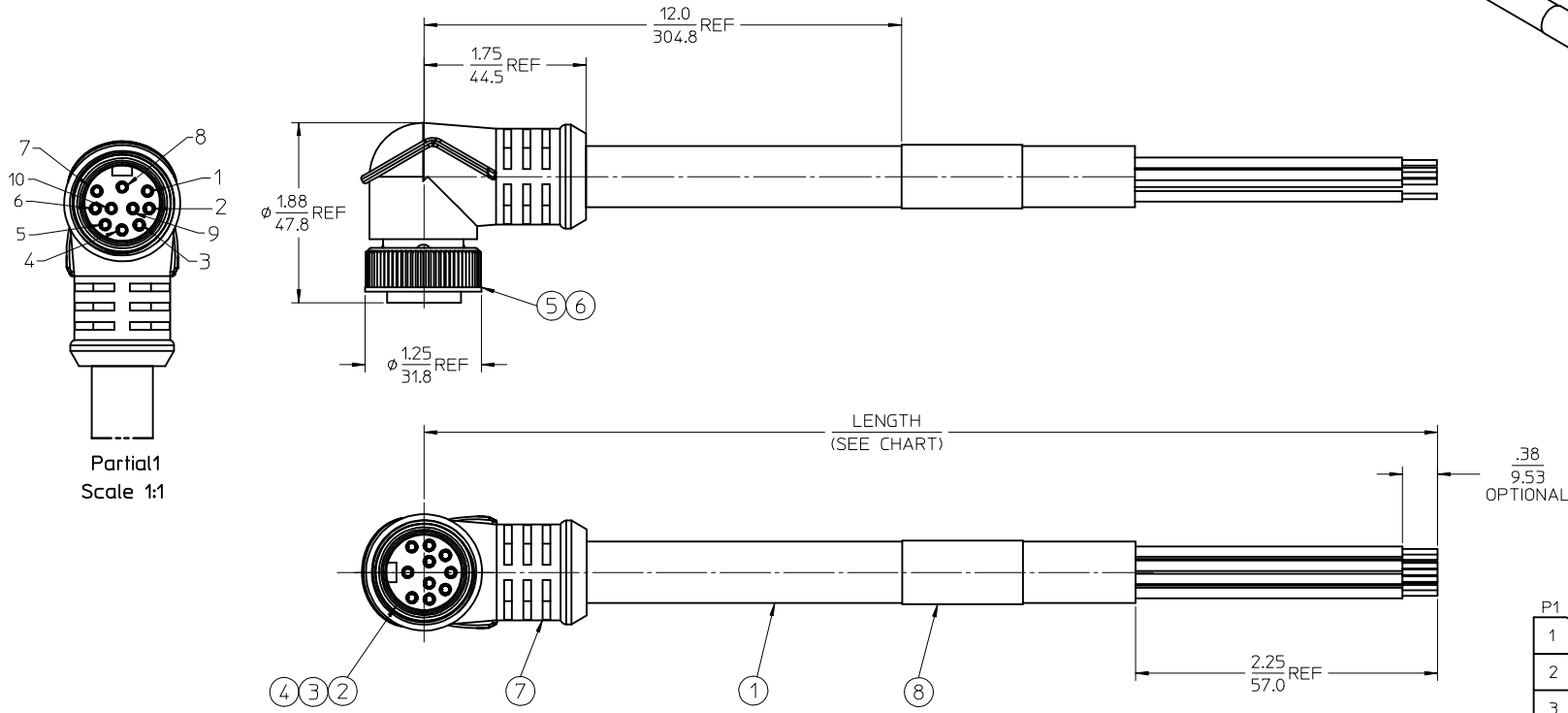
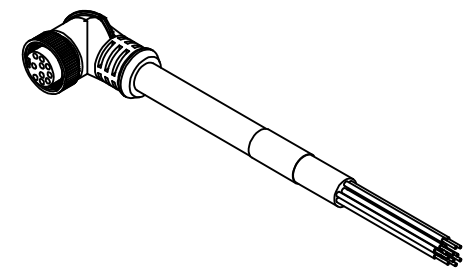

Partial1
Scale 1:1

P1	Color
1	ORANGE
2	BLUE
3	WHITE/BLACK TRACE
4	RED/BLACK TRACE
5	GREEN/BLACK TRACE
6	ORANGE/BLACK TRACE
7	RED
8	GREEN - GND
9	BLACK
10	WHITE

WIRING DIAGRAM

- NOTES:
1. MATERIAL: SEE TABLE
 2. FINISHES: SEE TABLE
 3. CABLE ASSEMBLIES ARE BAGGED SEPERATELY IN POLY BAGS WITH BARCODE LABEL ATTACHED TO OUTSIDE OF BAG
 4. WRAP LABEL IS MARKED WITH P/N, DATE CODE VOLTAGE & AMPERAGE
 5. MATES WITH: MINI CHANGE, C-SIZE 10 POLE RECEPTACLE
 6. ELECTRICAL SPECIFICATIONS:
VOLTAGE RATING: 600V
CURRENT RATING: 7 AMPS
 7. ASSEMBLY IS RoHS COMPLIANT

ITEM	QTY.	DESCRIPTION	MATERIAL	FINISH
8	1	LABEL	PLASTIC FILM	BLACK/YELLOW
7	1	OVERMOLD	PVC	YELLOW
6	1	COUPLING NUT	ZINC DIE CAST	BLACK
5	1	FRICITION RING	NYLON	NATURAL
4	10	SOCKET CONTACT	BRASS	GOLD PLATED
3	10	SOCKET SLEEVE, 16 AWG	STAINLESS	
2	1	INSERT, FEMALE, 10 POLE	PVC	YELLOW
1	1	CABLE - YELLOW ST00W	PVC JACKET	YELLOW
			MATERIAL	FINISH

NEW DOCUMENT EC NO: WNAZ010-0094 DRW:BRUPERT 2009/08/24 CHKD:WOODMAN 2009/08/26 APPR:JFMURPHY 2009/08/27	QUALITY SYMBOLS ▽=0 ▽=0	GENERAL TOLERANCES (UNLESS SPECIFIED)		DIMENSION STYLE IN/MM		SCALE 1:1	DESIGN UNITS INCH	THIRD ANGLE PROJECTION	
		4 PLACES ± --- ± --- 3 PLACES ± --- ± --- 2 PLACES ± --- ± --- 1 PLACE ± --- ± ---	mm INCH ± --- ± --- ± --- ± --- ± --- ± --- ± --- ± ---	DRAWN BY B. RUPERT	DATE 2009/07/06	TITLE MC 10 POLE, FEMALE C-SIZE SINGLE ENDED R/A			
		APPROVED BY JFMURPHY		DATE 2009/08/26	MOLEX INCORPORATED				
		DRAFT WHERE APPLICABLE MUST REMAIN WITHIN DIMENSIONS		MATERIAL NO. SEE CHART	DOCUMENT NO. SD-130008-016	SHEET NO. 1 OF 1			

THIS DRAWING CONTAINS INFORMATION THAT IS PROPRIETARY TO MOLEX INCORPORATED AND SHOULD NOT BE USED WITHOUT WRITTEN PERMISSION