

IS31PW8200

LI+ DUAL BATTERY CONTROLLER

December 2013

GENERAL DESCRIPTION

The IS31PW8200 is a highly integrated IC to serve as the control logic for a system with multiple power sources. It integrates a mini-charger's path power MOS with a switchable bulk and saves the external diode in mini-charger path. Also, it directly drives the internal P-channel MOSFETs to select the power path for the system and manages dual battery sources for charge and discharge. The power path selection is made based on the present voltage of the power sources and the state of charge of the batteries.

Additionally, IS31PW8200 integrates an I²C block to communicate with the Base Band. At start up, the baseband reads out the status of the dual battery sources. During operation, if the status changes, IS31PW8200 provides an interrupt to notify the baseband to update the information of the dual battery sources.

IS31PW8200 is available in QFN-20 (3mm × 3mm) package. It operates from 2.4V to 5.5V over the temperature range of -40°C to +85°C.

FEATURES

- 2.4V to 5.5V supply voltage
- I²C interface
- Complete power path management for dual battery systems
- Dual battery status monitor
- Integrated charger path switches
- Hardware reset function
- Operating temperature T_A = -40°C ~ 85°C
- QFN-20 (3mm × 3mm) package

APPLICATIONS

- Cellular phones
- PDAs
- Portable electronics

TYPICAL APPLICATION CIRCUIT

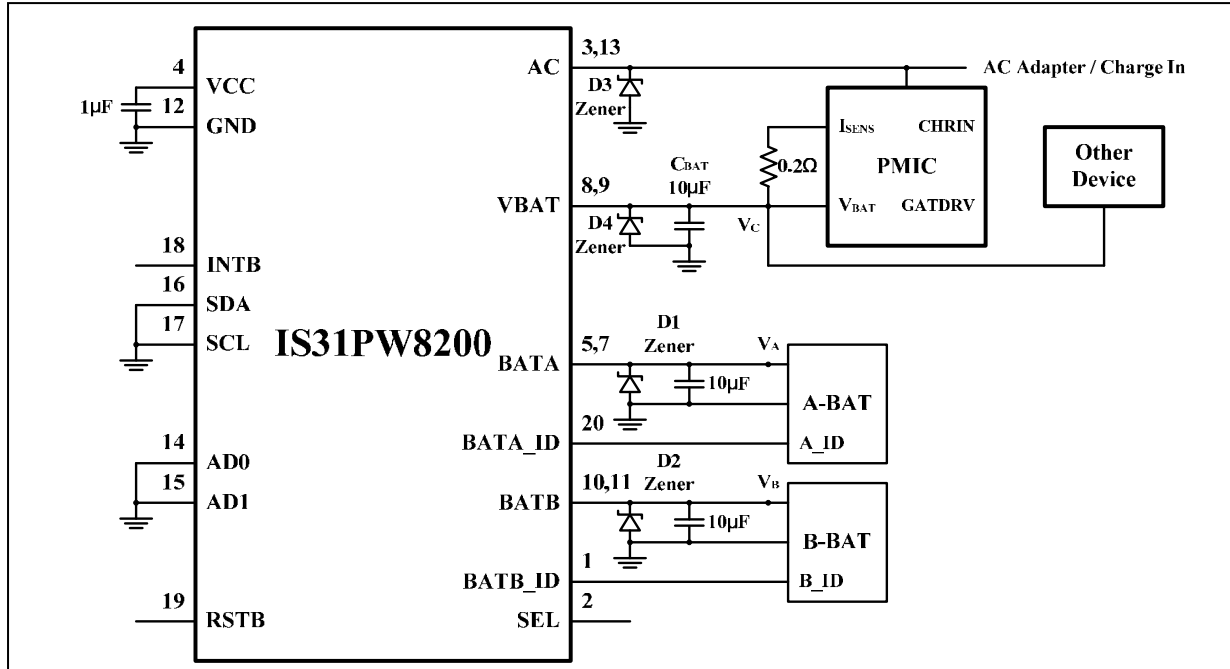

Figure 1 Typical Application Circuit

IS31PW8200

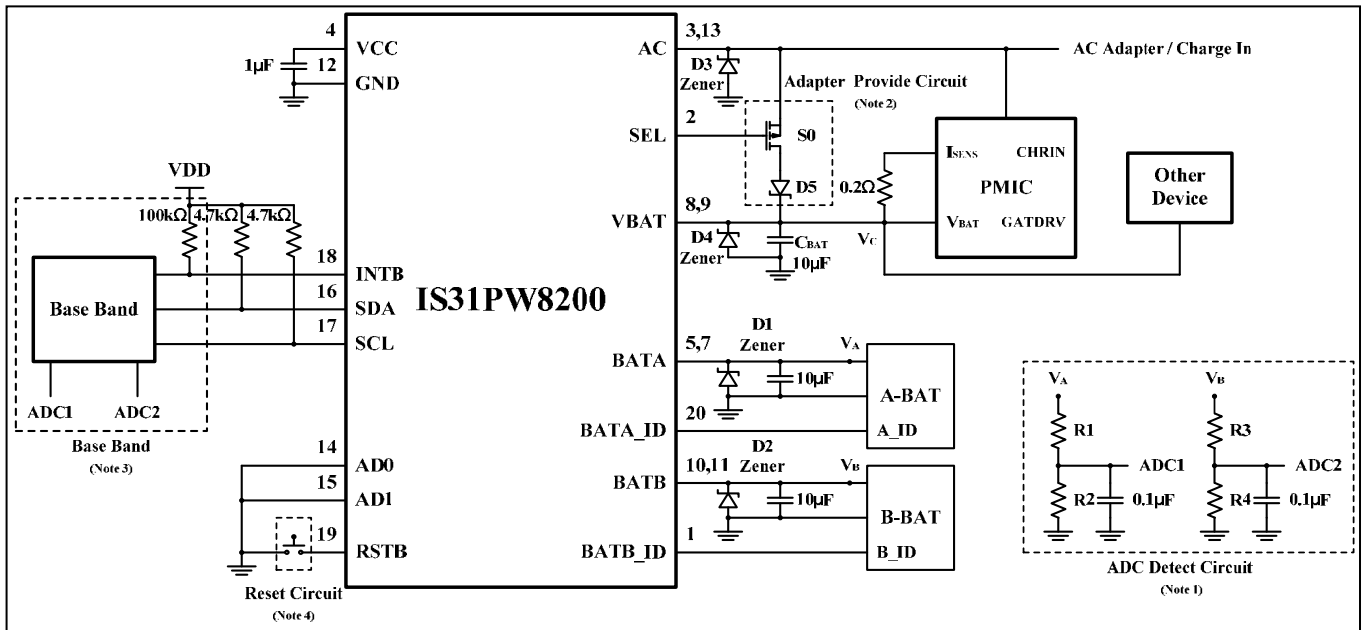

Figure 2 Typical Application Circuit

Note 1: Two ADC circuits can be used to detect the battery voltage. Connecting to the VC point if only one ADC. This circuit can be connected or not.

In MTK Platform, R1=R3=470kΩ, R2=R4=300kΩ. In Zhanxun Platform, R1=R3=470kΩ, R2=R4=100kΩ.

Note 2: The adapter provides power for system when the adapter plugs in and no batteries connected. Please refer to Page 12 to get the detail information. This circuit can be connected or not.

Note 3: Base Band can control and read the dual batteries information. Please refer to Page 9 to get the detail information. This circuit can be connected or not. Register configuration is default if there is no connection.

Note 4: If use the two-pin battery, BATA_ID and BATB_ID pins should connect a 10kΩ resistor to ground. Three-pin battery is recommended.

IS31PW8200

PIN CONFIGURATION

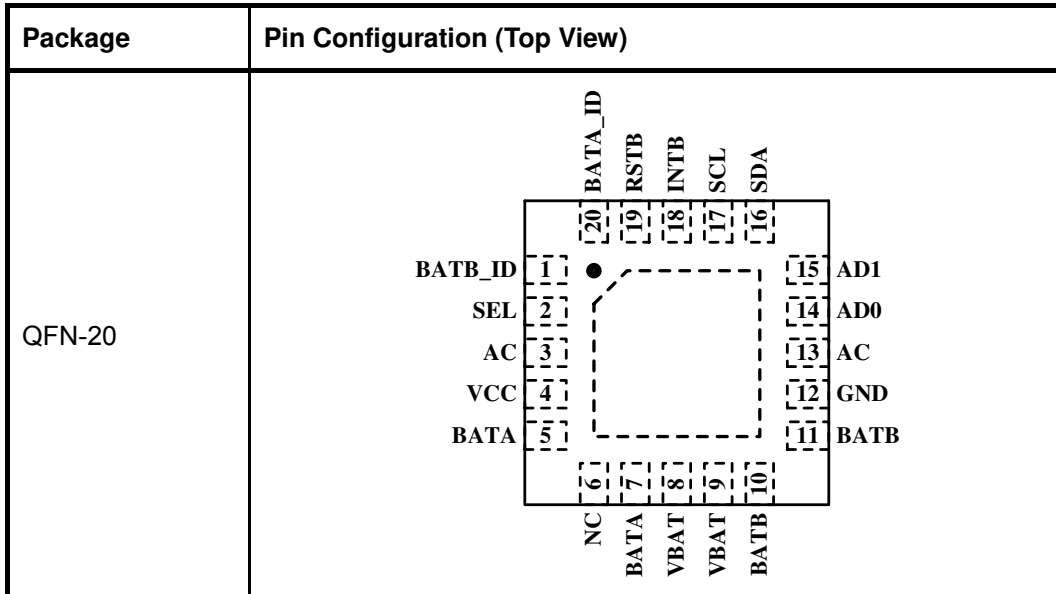

PIN DESCRIPTION

Pin	Name	Function
1	BATB_ID	Indication that Li-ion Battery B is inserted.
2	SEL	Control output to the gate of the external PMOS for AC adapter input as power source.
3, 13	AC	AC adapter input.
4	VCC	Power supply.
5, 7	BATA	Battery A connection.
6	NC	No connect.
8, 9	VBAT	Current source output.
10, 11	BATB	Battery B connection.
12	GND	Ground.
14	AD0	Address input. Select device slave address.
15	AD1	Address input. Select device slave address.
16	SDA	I2C compatible serial data.
17	SCL	I2C compatible serial clock.
18	INTB	Interrupt output. Active low.
19	RSTB	Reset input. Active low. Cut the power path to PMU and reset I2C.
20	BATA_ID	Indication that Li-ion Battery A is inserted.
	Thermal Pad	Connect to GND.



IS31PW8200

ORDERING INFORMATION

INDUSTRIAL RANGE: -40°C TO +85°C

Order Part No.	Package	QTY/Reel
IS31PW8200-QFLS2-TR	QFN-20, Lead-free	2500

Copyright © 2013 Integrated Silicon Solution, Inc. All rights reserved. ISSI reserves the right to make changes to this specification and its products at any time without notice. ISSI assumes no liability arising out of the application or use of any information, products or services described herein. Customers are advised to obtain the latest version of this device specification before relying on any published information and before placing orders for products. Integrated Silicon Solution, Inc. does not recommend the use of any of its products in life support applications where the failure or malfunction of the product can reasonably be expected to cause failure of the life support system or to significantly affect its safety or effectiveness. Products are not authorized for use in such applications unless Integrated Silicon Solution, Inc. receives written assurance to its satisfaction, that:

- a.) the risk of injury or damage has been minimized;
- b.) the user assume all such risks; and
- c.) potential liability of Integrated Silicon Solution, Inc is adequately protected under the circumstances



IS31PW8200

ABSOLUTE MAXIMUM RATINGS

Supply voltage, AC, BATA, BATB	-0.3V ~ +6.0V
Voltage at any input pin	-0.3V ~ +6.0V
Maximum junction temperature, T_{JMAX}	150°C
Operating temperature range, T_A	-40°C ~ +85°C
Storage temperature range, T_{STG}	-65°C ~ +150°C
ESD (HBM)	1kV
ESD (CDM)	1kV

Note:

Stresses beyond those listed under "Absolute Maximum Ratings" may cause permanent damage to the device. These are stress ratings only and functional operation of the device at these or any other condition beyond those indicated in the operational sections of the specifications is not implied. Exposure to absolute maximum rating conditions for extended periods may affect device reliability.

DC CHARACTERISTICS

$T_A = -40^\circ\text{C} \sim +85^\circ\text{C}$, $V_{CC} = 2.4\text{V} \sim 5.5\text{V}$, unless otherwise noted. Typical value are $T_A = +25^\circ\text{C}$. (Note 5)

Symbol	Parameter	Condition	Min.	Typ.	Max.	Unit
V_{CC}	Supply voltage		2.4		5.5	V
V_{TH1}	Switch threshold voltage 1	V_{TH1} bit set to "0" in Configuration Register(01h)	3.44	3.5	3.56	V
V_{TH2}	Switch threshold voltage 2	V_{TH2} bit set to "0" in Configuration Register(01h)		3.2		V
V_{HY}	V_{TH1} hysteresis voltage	HV bit set to "0" in Configuration Register(01h)		0.1		V
I_{CC}	Quiescent current	$V_{BATA} = V_{BATB} = 4.2\text{V}$ Without adapter plugging in		100		μA
		$V_{BATA} = V_{BATB} = 4.2\text{V}$ With Adapter plugging in			5	mA
t_D	V_{TH1} switching timing delay	Page 11		2		ms
I_{CH}	Charge current		95	120	155	mA
V_{OVP}	Over voltage protect			4.1	4.3	V
$R_{DS(ON)}$	On resistance of MOSFET			100		m Ω
t_{SW}	Switching delay		120	150	180	ns

Logic Electrical Characteristics (SDA, SCL, AD0, AD1, INTB)

V_{IH}	Input high voltage		1.4			V
V_{IL}	Input low voltage				0.4	V
I_{IH}, I_{IL}	Input leakage current		-0.2		0.2	μA
C_{IN}	Input capacitance (Note 6)			10		pF
V_{OLSDA}	Output low voltage SDA	$I_{SINK} = 6\text{mA}$			180	mV
V_{OLINT}	Output low-voltage INTB	$I_{SINK} = 5\text{mA}$			180	mV

IS31PW8200

DIGITAL INPUT SWITCHING CHARACTERISTICS (Note 6)

Symbol	Parameter	Condition	Min.	Typ.	Max.	Unit
f_{SCL}	Serial-Clock frequency				400	kHz
t_{BUF}	Bus free time between a STOP and a START condition		1.3			μ s
$t_{HD, STA}$	Hold time (repeated) START condition		0.6			μ s
$t_{SU, STA}$	Repeated START condition setup time		0.6			μ s
$t_{SU, STO}$	STOP condition setup time		0.6			μ s
$t_{HD, DAT}$	Data hold time	(Note 7)			0.9	μ s
$t_{SU, DAT}$	Data setup time		100			ns
t_{LOW}	SCL clock low period		1.3			μ s
t_{HIGH}	SCL clock high period		0.7			μ s
t_R	Rise time of both SDA and SCL signals, receiving	(Note 8)		$20+0.1C_b$	300	ns
t_F	Fall time of both SDA and SCL signals, receiving	(Note 8)		$20+0.1C_b$	300	ns
$t_{F, TX}$	Fall time of SDA transmitting	(Note 8)		$20+0.1C_b$	250	ns
t_{SP}	Pulse width of spike suppressed	(Note 9)		50		ns
C_b	Capacitive load for each bus line				400	pF
t_W	RSTB pulse width		500			ns
t_{RSTB}	RSTB rising to START condition setup time		1			ns

Note 5: All parameters are tested at $T_A = 25^\circ\text{C}$. Specifications over temperature are guaranteed by design.

Note 6: Guaranteed by design.

Note 7: A master device must provide a hold time of at least 300ns for the SDA signal (referred to V_{IL} of the SCL signal) in order to bridge the undefined region of SCL's falling edge.

Note 8: C_b = total capacitance of one bus line in pF. $I_{SINK} \leq 6\text{mA}$. t_R and t_F measured between $0.3 \times V_{CC}$ and $0.7 \times V_{CC}$.

Note 9: Input filters on the SDA and SCL inputs suppress noise spikes less than 50ns.

IS31PW8200

DETAILED DESCRIPTION

I2C INTERFACE

The IS31PW8200 uses a serial bus, which conforms to the I2C protocol, to control the chip's functions with two wires: SCL and SDA. The IS31PW8200 has a 7-bit slave address (A7:A1), followed by the R/W bit, A0. Set A0 to "0" for a write command and set A0 to "1" for a read command. The bit A2:A1 are selected by the connection of AD1/AD0 pin.

The complete slave address is:

Table 1 Slave Address:

Bit	A7:A3	A2	A1	A0
Value	10111	AD1	AD0	1/0

AD1/AD0 connects to VCC, AD1/AD0=1;

AD1/AD0 connects to GND, AD1/AD0=0;

The SCL line is uni-directional. The SDA line is bi-directional (open-collector) with a pull-up resistor (typically 4.7kΩ). The maximum clock frequency specified by the I2C standard is 400kHz. In this discussion, the master is the microcontroller and the slave is the IS31PW8200.

The timing diagram for the I2C is shown in Figure 3. The SDA is latched in on the stable high level of the SCL. When there is no interface activity, the SDA line should be held high.

The "START" signal is generated by lowering the SDA signal while the SCL signal is high. The start signal will alert all devices attached to the I2C bus to check the incoming address against their own chip address.

The 8-bit chip address is sent next, most significant bit first. Each address bit must be stable while the SCL level is high.

After the last bit of the chip address is sent, the master checks for the IS31PW8200's acknowledge. The

master releases the SDA line high (through a pull-up resistor). Then the master sends an SCL pulse. If the IS31PW8200 has received the address correctly, then it holds the SDA line low during the SCL pulse. If the SDA line is not low, then the master should send a "STOP" signal (discussed later) and abort the transfer.

Following acknowledge of IS31PW8200, the register address byte is sent, most significant bit first. IS31PW8200 must generate another acknowledge indicating that the register address has been received.

Then 8-bit of data byte are sent next, most significant bit first. Each data bit should be valid while the SCL level is stable high. After the data byte is sent, the IS31PW8200 must generate another acknowledge to indicate that the data was received.

The "STOP" signal ends the transfer. To signal "STOP", the SDA signal goes high while the SCL signal is high.

WRITING TO THE REGISTERS

Transmit data to the IS31PW8200 by sending the device slave address and setting the LSB to "0". The command byte is sent after the address and determines which registers receive the data following the command byte.

READING PORT REGISTERS

To read the device data, the bus master must first send the IS31PW8200 address with the R/W bit set to "0", followed by the command byte, which determines which register is accessed. After a restart, the bus master must then send the IS31PW8200 address with the R/W bit set to "1". Data from the register defined by the command byte is then sent from the IS31PW8200 to the master (Figure 6).

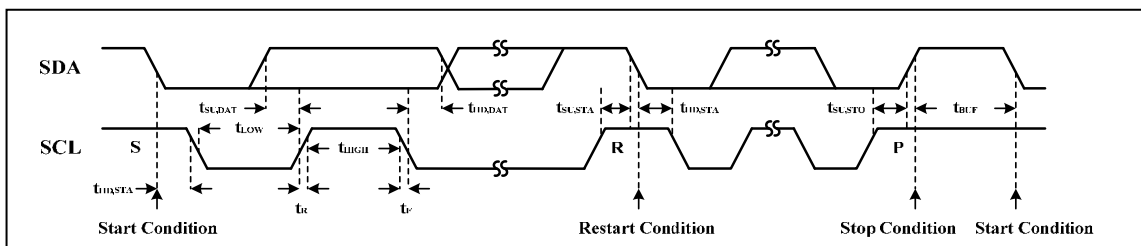

Figure 3 Interface Timing

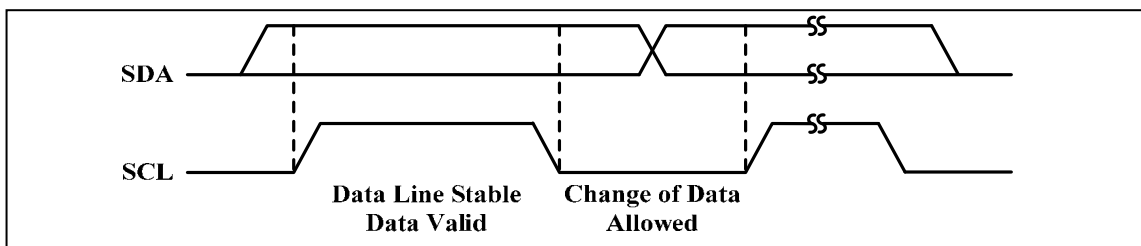

Figure 4 Bit Transfer

IS31PW8200

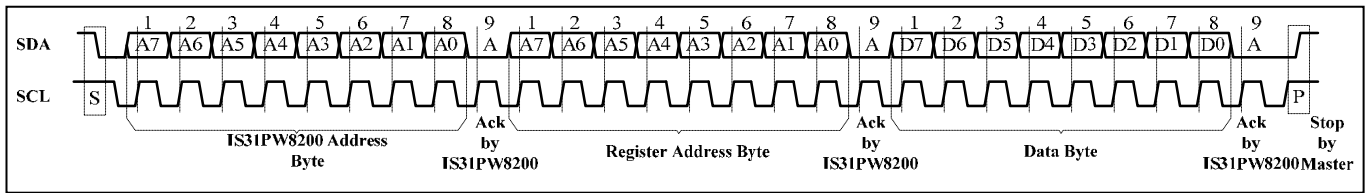

Figure 5 Writing to IS31PW8200

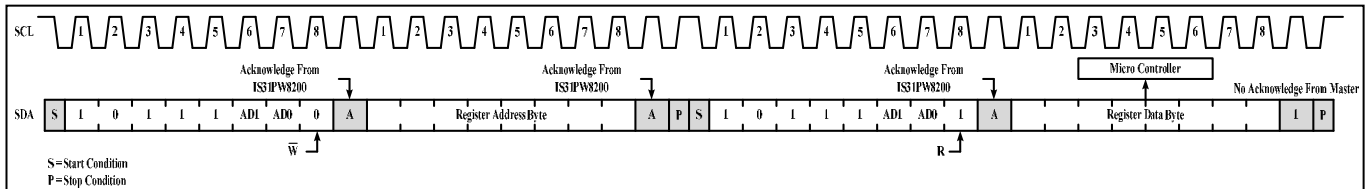

Figure 6 Reading from IS31PW8200

REGISTERS DEFINITIONS

Table 2 Register Function

Address	Name	Function	Table	R/W	Default
00h	State Register	Store the state of batteries	3	R	-
01h	Configuration Register	Set the operation voltage and power selection	4	R/W	xx00 0000
0Fh	Reset Register	Reset all registers to default value	-	W	xxxx xxxx

Table 3 00h State Register (Read only)

Bit	D7	D6	D5:D4	D3:D2	D1:D0
Name	BI	AI	BS	BVD	AVD
R/W	R				
Default	-				

The State Register stores the state information for A-BAT and B-BAT.

BI B-BAT ID Connection
 0 Battery in (BATB-ID is high)
 1 Battery out (BATB-ID is low)

AI A-BAT ID Connection
 0 Battery in (BATA-ID is high)
 1 Battery out (BATA-ID is low)

BS Battery State
 00 A-BAT Connect
 01 B-BAT Connect
 11 Both A-BAT and B-BAT disconnect and AC adapter supply power
 Others Not available

BVD B-BAT Voltage Detection
 00 $V_{B-BAT} < V_{TH2}$
 01 $V_{TH2} < V_{B-BAT} < V_{TH1}$
 10 $V_{TH1} < V_{B-BAT} < 4.2V$
 11 $V_{B-BAT} \geq 4.2V$

AVD A-BAT Voltage Detection
 00 $V_{A-BAT} < V_{TH2}$
 01 $V_{TH2} < V_{A-BAT} < V_{TH1}$
 10 $V_{TH1} < V_{A-BAT} < 4.2V$
 11 $V_{A-BAT} \geq 4.2V$

IS31PW8200

Table 4 01h Configuration Register

Bit	D7	D5	D5:D4	D3:D2	D1	D0
Name	SB	SA/CS	PS	HV	V _{TH1}	V _{TH2}
R/W	R	R/W	W	W	W	W
Default	-	-/0	00	00	0	0

The Configuration Register sets operating mode and the power source.

SB Internal Charger Charge up for B-BAT (Read only)

0 Charge
1 Off

SA(R) Hysteresis Voltage Charge up for A-BAT (Read only)

0 Charge
1 Off

CS(W) Internal Charger Control

0 On
1 Off

PS Power Selection

00 Default
01 A-BAT
10 B-BAT
Others Not available

HV Hysteresis Voltage for V_{TH1}

00 0.10V
10 0.05V
Others Not available

V_{TH1} Threshold Voltage 1

0 3.5V
1 3.6V

V_{TH2} Threshold Voltage 2

0 3.2V
1 3.3V

0Fh Reset Register

Once user writes "0000 0000" data to the Reset Register, IS31PW8200 will reset all registers to their default value. On initial power-up, the IS31PW8200 registers are reset to their default values.

IS31PW8200

FUNCTIONAL BLOCK DIAGRAM

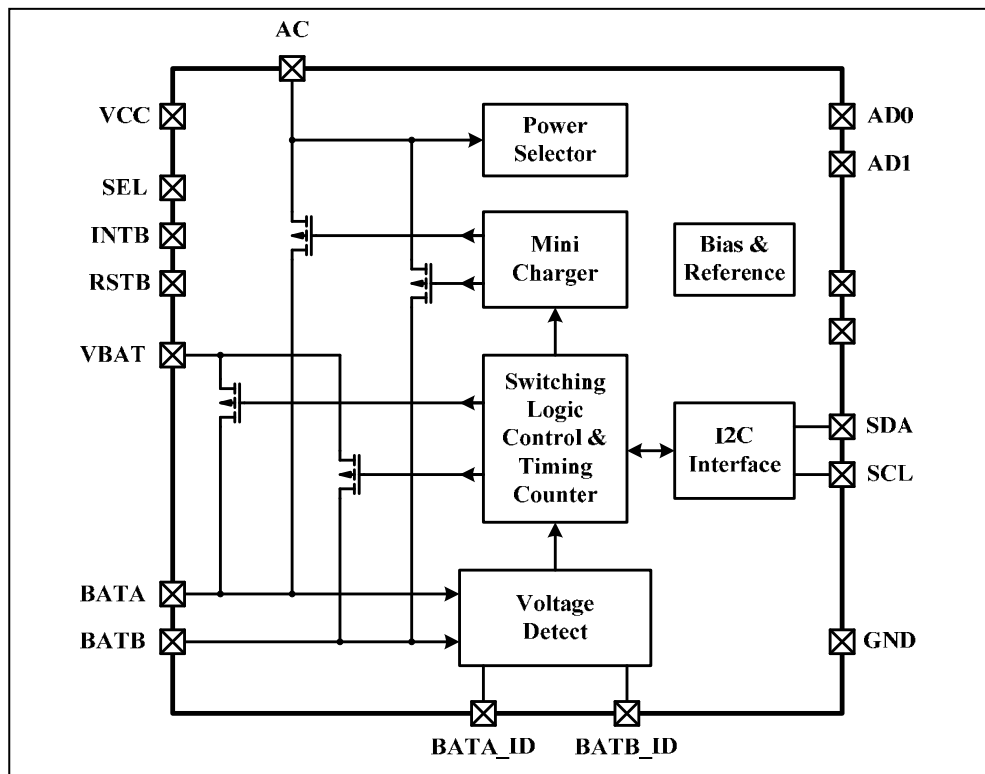

IS31PW8200

APPLICATION INFORMATION

DUAL BATTERIES SWITCHING FOR PROVIDING POWER

The IS31PW8200 highly integrated IC serves as the control logic for a system with multiple power sources. It selects the power path for the system and manages dual battery sources for charge and discharge.

SWITCH CONDITION IN DISCHARGE MODE (WITHOUT ADAPTER PLUGGED IN):

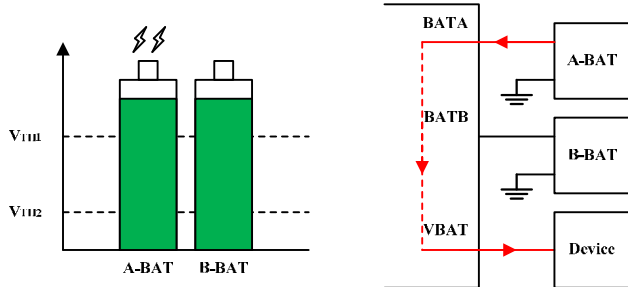

State 1: If $V_{A-BAT} \geq V_{TH1}$ and $V_{B-BAT} \geq V_{TH1}$, A-BAT provides power.

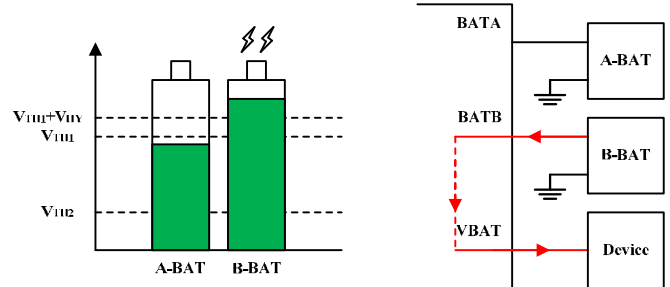

State 2: If $V_{A-BAT} \leq V_{TH1}$ and lasts for t_D and $V_{B-BAT} \geq V_{TH1} + V_{HY}$, switch to B-BAT providing power.

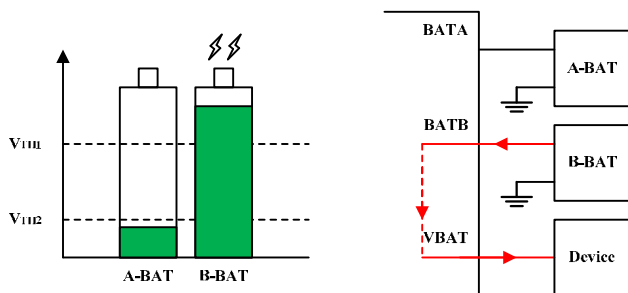

State 3: If $V_{A-BAT} \leq V_{TH2}$ and $V_{B-BAT} \geq V_{TH1}$, switch to B-BAT providing power immediately.

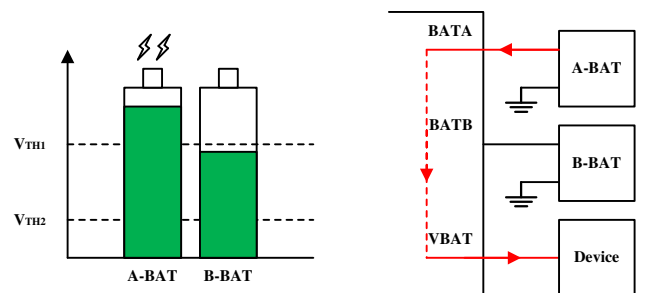

State 4: If $V_{A-BAT} \geq V_{TH1}$ and $V_{TH2} \leq V_{B-BAT} \leq V_{TH1}$, A-BAT provides power.

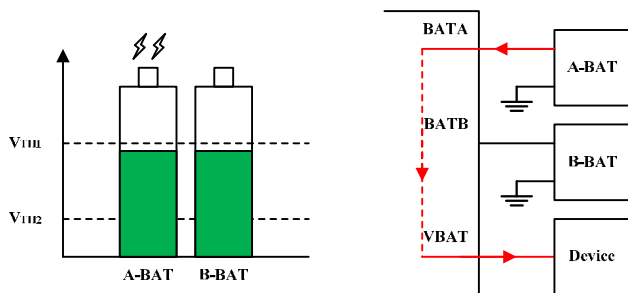

State 5: If $V_{TH2} \leq V_{A-BAT} \leq V_{TH1}$ and $V_{TH2} \leq V_{B-BAT} \leq V_{TH1}$, A-BAT provides power.

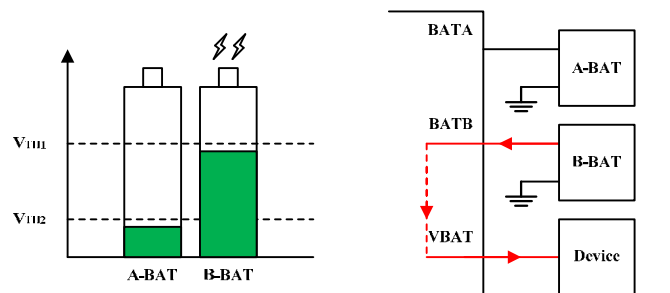

State 6: If $V_{A-BAT} \leq V_{TH2}$ and $V_{TH2} \leq V_{B-BAT} \leq V_{TH1}$, switch to B-BAT providing power.

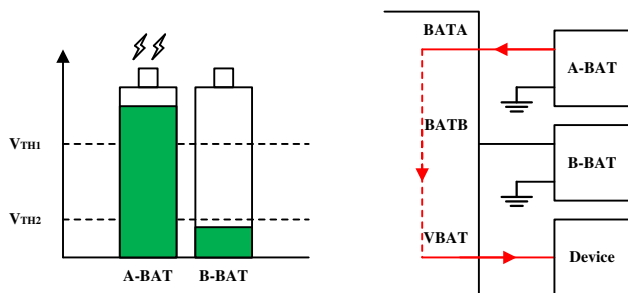

State 7: If $V_{B-BAT} \leq V_{TH2}$, A-BAT provides power all the time.

Note: When V_{A-BAT} and V_{B-BAT} are both higher than V_{TH2} , IS31PW8200 can force switching the battery source by setting the PS bit in Configuration Register (01h).

After forcing a battery selection, the system will continue to automatically choose the supply battery in accordance with the conditions as described if the battery's voltage falls below V_{TH2} , until the voltage returns back to V_{TH2} again making the selected battery available.

IS31PW8200

SWITCH CONDITION IN CHARGE MODE (WITH ADAPTER PLUGGED IN):

Charge rules:

When the adapter is plugged in, the PMIC charges the supply battery and the internal charger provides a small current for the unused battery. Internal charger provides a 20mA current for the unused battery which below V_{TH2} until the voltage of the battery reaches V_{TH2} then provides a 150mA current.

The voltage of battery changes during charging. The charging rules should follow the switch condition below. The internal charger will disconnect automatically if batteries are both full.

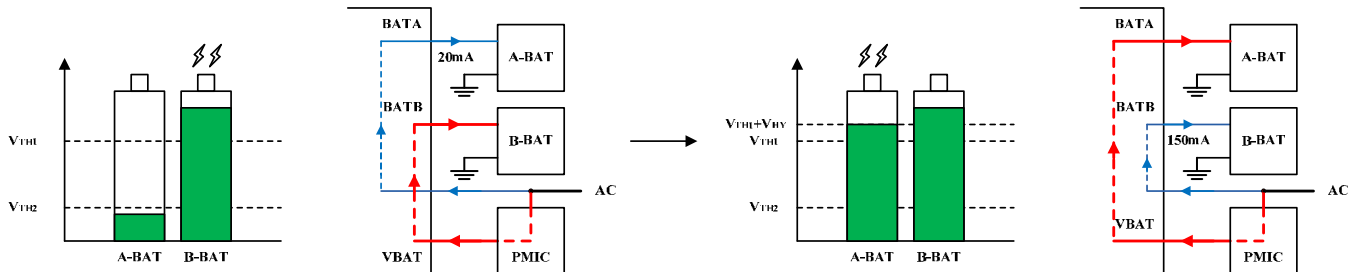

State 1: If $V_{A-BAT} \leq V_{TH2}$ and $V_{B-BAT} \geq V_{TH1}$, B-BAT provides power. The PMIC charges up B-BAT and IS31PW8200 provides small current (20mA) for A-BAT by internal charger at the same time. The battery source will not switch until V_{A-BAT} reaches to $V_{TH1}+V_{HY}$.

State 2: If V_{A-BAT} charges up to $V_{TH1}+V_{HY}$ and $V_{B-BAT} \geq V_{TH1}$, switch to A-BAT providing power. The PMIC charges up A-BAT and IS31PW8200 provides small current (150mA) for B-BAT by internal charger at the same time until batteries are both full.

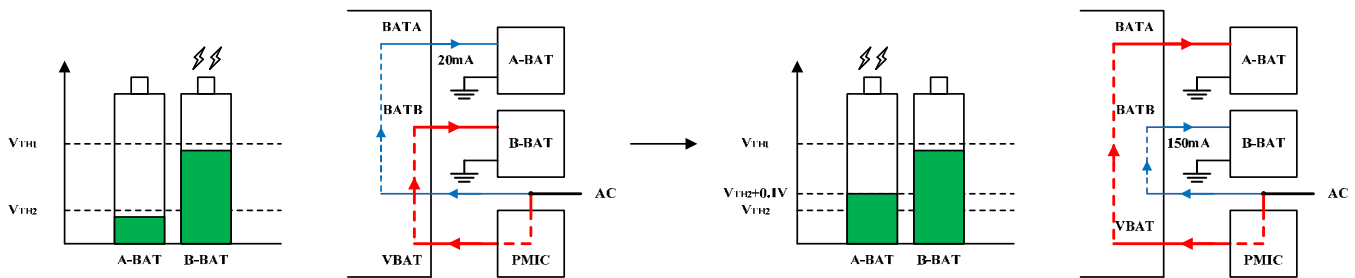

State 3: If $V_{A-BAT} \leq V_{TH2}$ and $V_{TH2} \leq V_{B-BAT} \leq V_{TH1}$, B-BAT provides power. The PMIC charges up for B-BAT and IS31PW8200 provides small current (20mA) for A-BAT by internal charger at the same time. The battery source will not switch until V_{A-BAT} reaches $V_{TH2}+0.1V$.

State 4: If V_{A-BAT} charges up to $V_{TH2}+0.1V$ and $V_{TH2} \leq V_{B-BAT} \leq V_{TH1}$, switch to A-BAT providing power. The PMIC charges up for A-BAT and IS31PW8200 provides small current (150mA) for B-BAT by internal charger at the same time until batteries are both full.

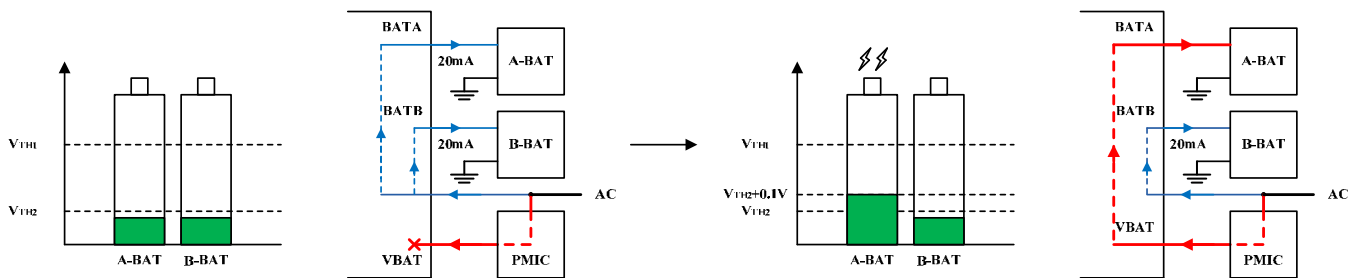

State 5: If $V_{A-BAT} \leq V_{TH2}$ and $V_{B-BAT} \leq V_{TH2}$, dual batteries disconnect with VBAT. At this moment, the PMIC doesn't charge up any batteries and IS31PW8200 provides small current (20mA) for dual batteries by internal charger until one of batteries is charged up to $V_{TH2}+0.1V$ and offer power by this battery.

State 6: If V_{A-BAT} charges up to $V_{TH2}+0.1V$ first and $V_{B-BAT} \leq V_{TH2}$, A-BAT provides power. The PMIC charges up A-BAT and IS31PW8200 provides small current (20mA) for B-BAT by internal charger at the same time until batteries are both full. It operates opposition situation if V_{B-BAT} charges up to $V_{TH2}+0.1V$ first.

Note: Stop charging when the B-BAT is full. If V_{B-BAT} falls below 4.0V for a period of more than 2s, B-BAT resumes charging again.

APPLICATIONS

IS31PW8200 can be used in multiple application configurations, for example, as shown in Figure 1 and Figure 2. Switching between the batteries follows the switching conditions as described above.

1. External battery: A-BAT is the external battery, such as in a cell phone cover, and B-BAT is the internal battery.
2. Built-in battery: A-BAT is a removable battery, and B-BAT is the permanent battery, both located inside of the mobile device.
3. Single battery: Either A-BAT and B-BAT can be used.

Note, for different cell phone systems, a low power warning or shutdown warning may occur even if the major battery's voltage doesn't fall below V_{TH1} . To handle this situation, forced switching of the supply battery via I2C interface by setting the PS bit in Configuration Register (01h) is available.

HYSTERESIS VOLTAGE

The hysteresis voltage is used to prevent continual switching between the two batteries and to ensure that A-BAT provides power as the major power source. If the voltage of the providing battery drops below the threshold voltage causing the power path to switch, it will switch back when the voltage returns to the threshold voltage plus the hysteresis voltage.

Setting the HV bits of Configuration Register (01h) configures the hysteresis voltage, V_{HY} . If the HV bits are set to "00", $V_{HY} = 0.1V$. If the HV bits are set to "01", $V_{HY} = 0.05V$. V_{HY} is the hysteresis voltage for V_{TH1} and the hysteresis voltage of V_{TH2} is fixed at 0.1V.

REGISTER FUNCTION CONFIGURATION

Configure the operating mode by setting the Configuration Register (01h).

By setting the CS bit to "0", the internal charger is on. When the CS bit is set to "1", the internal charger is off.

The PS bit is used to configure the power supply source. If the PS bits are set to "00", the system selects the power supply source automatically in accordance with the switch conditions described earlier. If the PS bits are set to "01", the system forces A-BAT to be the power supply source, and, finally, if the PS bits are set to "10" the system selects B-BAT to be the power supply source. Note that the forced power source selection is only valid if both V_{A-BAT} and V_{B-BAT} are higher than V_{TH2} . When both V_{A-BAT} and V_{B-BAT} are lower than V_{TH2} the cell phone will normally be shutdown. After connecting the charger, both V_{A-BAT} and V_{B-BAT} will begin charging. After both V_{A-BAT} and V_{B-BAT} are higher than V_{TH2} the IS31PW8200 will select the appropriate battery based on the existing

register content.

The V_{TH1} bit is used to set the threshold voltage, V_{TH1} . If V_{TH1} is set to "0", $V_{TH1} = 3.5V$. If V_{TH1} is set to "1", $V_{TH1} = 3.6V$.

The V_{TH2} bit is used to set the threshold voltage, V_{TH2} . If V_{TH2} is set to "0", $V_{TH2} = 3.2V$. If V_{TH2} is set to "1", $V_{TH2} = 3.3V$.

BATTERIES STATE INFORMATION

State Register (00h) is a read-only register, storing the state information for both batteries.

The BI bit indicates the B-BAT connection state. If BATB_ID is pulled to high, the BI bit is set to "0". If BATB_ID is pulled to low, the BI bit is set to "1".

The AI bit indicates the A-BAT connection state. If BATA_ID is pulled to high, the AI bit is set to "0". If BATA_ID is pulled to low, the AI bit is set to "1".

The BS bits are used to show the battery state. If A-BAT provides power, the BS bits are set to "00". If B-BAT provides power, the BS bits are set to "01". If the power supply is provided by the adapter and no connection with A-BAT and B-BAT, the BS bits are set to "11".

The BVD bits show the voltage state of B-BAT. If $V_{B-BAT} < V_{TH2}$, the BVD bits are set to "00". If $V_{TH2} < V_{B-BAT} < V_{TH1}$, the BVD bits are set to "01". If $V_{TH1} < V_{B-BAT} < 4.2V$, the BVD bits are set to "10". If $V_{B-BAT} \geq 4.2V$, the BVD bits are set to "11".

The AVD bits show the voltage state of A-BAT. If $V_{A-BAT} < V_{TH2}$, the AVD bits are set to "00". If $V_{TH2} < V_{A-BAT} < V_{TH1}$, the AVD bits are set to "01". If $V_{TH1} < V_{A-BAT} < 4.2V$, the AVD bits are set to "10". If $V_{A-BAT} \geq 4.2V$, the AVD bits are set to "11".

The SA and SB bits are the read-only bit, storing the charging state of the internal charger.

The SA bit shows the A-BAT charging state of the internal charger. If the internal charger is charging A-BAT, the SA bit is set to "0". Conversely if the internal charger is not charging A-BAT, the SA bit is set to "1".

The SB bit shows the B-BAT charging state by internal charger. If the internal charger is charging B-BAT, the SB bit is set to "0". Conversely if the internal charger is not charging B-BAT, the SB bit is set to "1".

Note, the SA bit and the CS bit are the same bit in Configuration Register (01h) which corresponding to reading and writing operation (Table 4). The internal charger can be controlled by the CS bit. Setting the CS bit to "1" shuts down the internal charger and, thus, it will not charge either of the batteries. In this case, both the SA and SB bits will be set to "1". If the internal charger is on, the SA and SB bits will indicate which batteries are being charged by the internal charger.

IS31PW8200

INTERRUPT FUNCTION

A latching interrupt output, INTB, is programmed to flag battery status changes. At start up, the IS31PW8200 will always assert the INTB. This ensures that the baseband will read the initial status of the batteries, as well as clear the interrupt signal. Any subsequent changes to the battery status will cause the INTB to be asserted. The state register will report the current status of the batteries even if the event causing the interrupt to be asserted has been cleared prior to the baseband reading the register and clearing the latched INTB signal.

BATTERY HOT-SWAP SOLUTION

The IS31PW8200 supports battery hot-swapping to ensure that the cell phone will not be shutdown during a battery change. IS31PW8200 will switch to the other battery as the power source if the supply battery is removed. In this case, the system will assert the interrupt indicating the batteries state changes.

HARDWARE RESET FUNCTION

IS31PW8200 has hardware reset function to handle the case where mobile device operating system is locked-up. Pulling the RSTB pin to low resets the IS31PW8200 to the default conditions and will follow the normal startup procedure once the RSTB pin is returned to a high level.

SINGLE BATTERY APPLICATION

For platform applications, there are certain cases where a single platform may be used for either single battery or dual battery applications. In the single battery applications, there is no need for the IS31PW8200 to be installed. Figure 7 shows the application circuit for a single battery. There is a 0Ω resistor between A-BAT/B-BAT and VBAT which must be installed for single battery applications.

Note: For dual battery applications, the IS31PW8200 is installed and the 0Ω resistors are not.

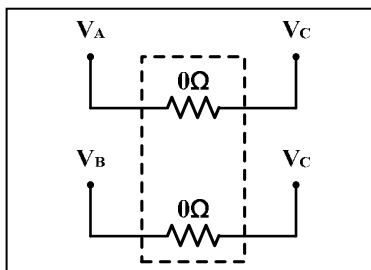

Figure 7 Single Battery Application Circuit

DESIGN NOTE

COMPONENT SELECTION

D1~D4 are the zener diodes using to prevent destroying the IC by high voltage. They should be placed close to the IC. D3 is used to prevent damage resulting from high voltage on the AC pin. The SOD-323 package is recommended.

When using the single battery configuration (Figure 7), take care to ensure a sufficient current rating for the 0Ω resistor(s). Three parallel 0Ω resistors in 0402 package or one 0Ω resistor in 0805 package are recommended.

The switching speed of IS31PW8200 can be 150ns. C_{BAT} in 10μF should be recommended.

All the capacitors should have a voltage rating of at least 10V.

In certain mobile applications it is acceptable to drive the mobile device directly from the AC adapter output. In these cases, the adapter providing circuit (PMOS + diode) must be installed. The FDFMA2P853 integrates a PMOS and diode into a single package to apply the AC adapter output directly to the VBAT pin. Please refer to the datasheet of the FDFMA2P853 to get more detailed information.

PCB LAYOUT

The zener diode, D1~D4 and the capacitors for A-BAT and B-BAT should be placed close to the IC. The trace of BAT-ID should be shielded to reduce interference and noise. All the traces connected to the BATA, BATB and VBAT pins should be as short and wide as possible.

Trace width should be at least 0.8mm when the current reaches 2A. Trace width should be at least 1.5mm when the current reaches 4A. Trace width should be at least 1.0mm for the power supply and the ground plane.

IS31PW8200

CLASSIFICATION REFLOW PROFILES

Profile Feature	Pb-Free Assembly
Preheat & Soak Temperature min (T _{smn}) Temperature max (T _{smax}) Time (T _{smn} to T _{smax}) (t _s)	150°C 200°C 60-120 seconds
Average ramp-up rate (T _{smax} to T _p)	3°C/second max.
Liquidous temperature (T _L) Time at liquidous (t _L)	217°C 60-150 seconds
Peak package body temperature (T _p)*	Max 260°C
Time (t _p)** within 5°C of the specified classification temperature (T _c)	Max 30 seconds
Average ramp-down rate (T _p to T _{smax})	6°C/second max.
Time 25°C to peak temperature	8 minutes max.

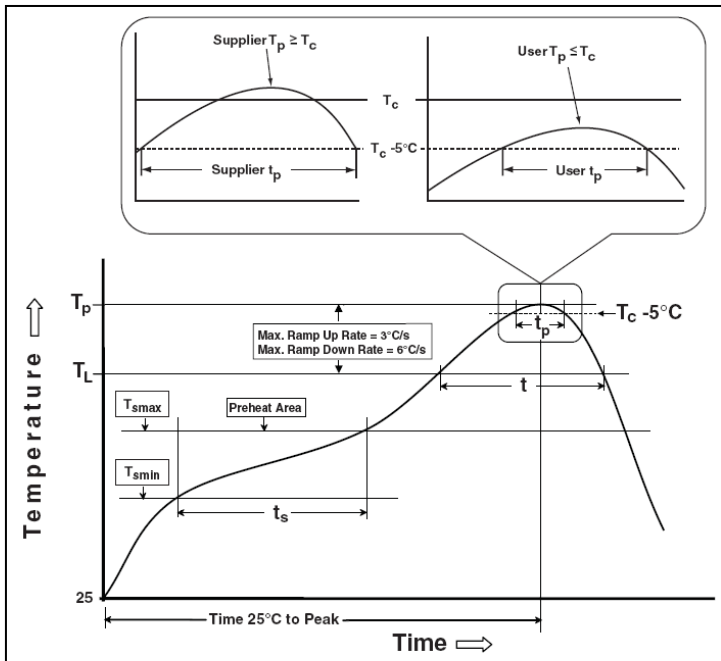
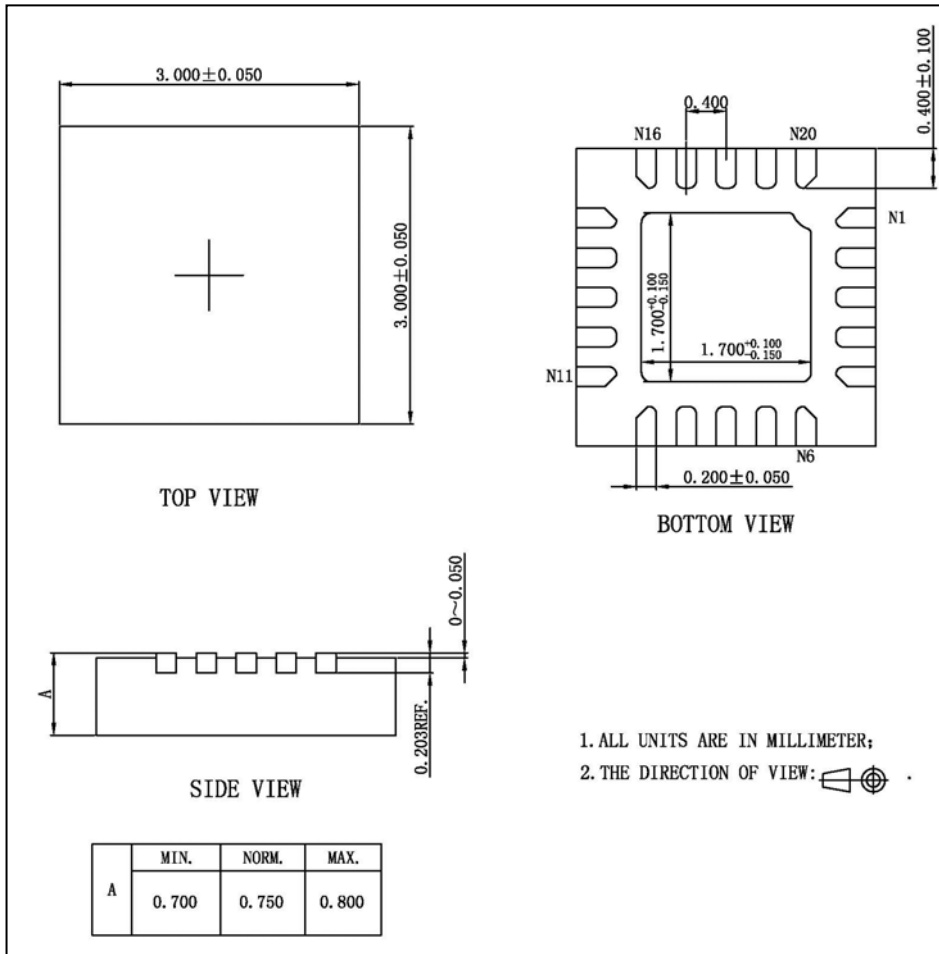

Figure 8 Classification Profile

IS31PW8200

PACKAGE INFORMATION

QFN-20



Note: All dimensions in millimeters unless otherwise stated.