

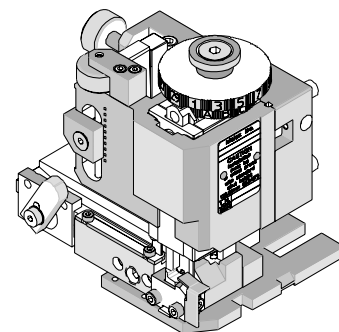

FineAdjust Applicator Specification Sheet Order No. 63900-1700



FEATURES

- Quick punch removal with the push of a button for fast and easy tooling change
- Applicator designed to industry standard mounting and shut height 135.80mm (5.346")
- Quick set-up time; plus the crimp height, track and feed adjustments can be set without removing the applicator from the press
- Fine adjustment allows users to achieve target with little effort by adjusting in increments of .015mm (.0006") for conductor crimp height and .063mm (.0025") for insulation height
- Independent adjustment rings allow users to quickly adjust the conductor or insulation crimp height without affecting each other
- Directly adapts to most automatic wire processing machines

SCOPE

Products: Sealed Mini Fit® H20 Male and Female Crimp Terminals, 18 - 20 AWG.

Terminal Series No.	Terminal Order No.	Wire Size		Insulation Diameter		Strip Length	
		AWG	mm ²	mm	In.	mm	In.
46055	46055-0004	18-20	0.80-0.50	2.52-2.81	.099-.111	2.60-3.10	.102-.122
	46055-0005						
	46055-0006						
46056	46056-0001	18-20	0.80-0.50	2.52-2.81	.099-.111	2.60-3.10	.102-.122
	46056-0002						
	46056-0003						

DEFINITION OF TERMS

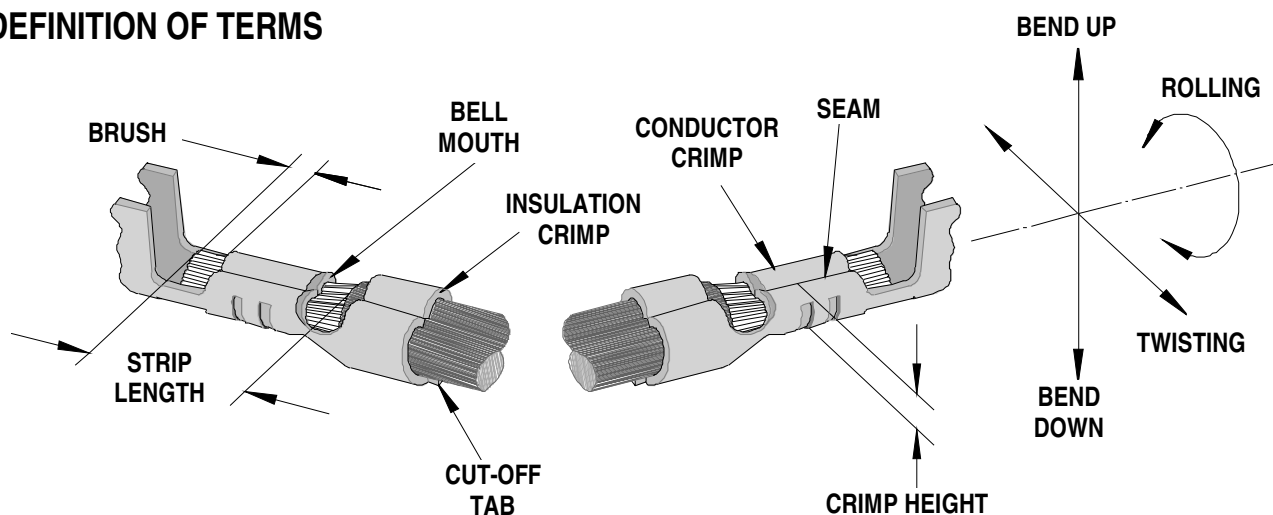

The above terminal drawing is a generic terminal representation. It is not an image of a terminal listed in the scope.

CRIMP SPECIFICATION

Terminal Series No.	Bell mouth		Cut-off Tab Maximum		Conductor Brush	
	mm	In.	mm	In.	mm	In.
46055	0.25-1.25	.010-.049	0.50	.020	0.15-0.40	.006-.016
46056	0.25-1.25	.010-.049	0.50	.020	0.15-0.40	.006-.016

Terminal Series No.	Bend up	Bend down	Twist	Roll	Punch Width (Ref)				Seam Seam shall not be open and no wire allowed out of the crimping area
	Degree		Degree		Conductor		Insulation		
					mm	In	mm	In	
46055	3	3	3	3	1.60	.063	2.75	.108	
46056	3	3	3	3	1.60	.063	2.75	.108	

After crimping, the conductor profile should measure the following.

Terminal Series No.	Wire Size		Conductor Crimp Height		Insulation Crimp Height Maximum		Pull Force Minimum	
	AWG	mm ²	mm	In.	mm	In.	N	Lb.
46055	18	0.80	1.05-1.15	.041-.045	3.20	.126	89.0	20.0
	20	0.50	1.00-1.10	.039-.043	3.20	.126	57.8	13.0
46056	18	0.80	1.05-1.15	.041-.045	3.20	.126	89.0	20.0
	20	0.50	1.00-1.10	.039-.043	3.20	.126	57.8	13.0

Pull Force should be measured with no influence from the insulation crimp.
The above specifications are guidelines to an optimum crimp.

PARTS LIST

FineAdjust Applicator 63900-1700				
Item	Order No	Engineering No.	Description	Quantity
Perishable Tooling				
	63900-1770	63900-1770	Tool Kit (All "Y" Items)	REF
1	63444-1613	63444-1613	Conductor Punch	1 Y
2	63455-0047	63455-0047	Conductor Anvil	1 Y
3	63454-0064	63454-0064	Insulation Punch	1 Y
4	63456-0043	63456-0043	Insulation Anvil	1 Y
5	63443-0037	63443-0037	Front Cut-Off Plunger	1 Y
6	63443-0038	63443-0038	Front Plunger Retainer	1 Y
Other Components (REF 001750)				
7	11-18-4083	60707-8	Feed Guide	1
8	63700-0539	63700-0539	Cut-Off Plunger Spring	1
9	11-40-4039	8302-5	Plunger Striker	1
10	63443-0009	63443-0009	Front Scrap Chute	1
11	63443-0024	63443-0024	Key	1
12	63443-0090	63443-0090	Wire Stop	1
13	63443-1719	63443-1719	18.90mm Height Spacer	1
14	63443-2216	63443-2216	16.00mm Coarse Spacer	1
15	63443-2301	63443-2301	3.05mm Fine Spacer	1
16	63443-6119	63443-6119	Rear Cover	1
Frame				
17	63800-4901	63800-4901	Top	1
18	63801-3281	63801-3281	Base	1
19	63801-4650	63801-4650	Track	1
Hardware				
20	N/A	N/A	M3 by 6 Long SHCS	2**
21	N/A	N/A	M3 by 6 Long FHCS	1**
22	N/A	N/A	M4 by 6 Long SHCS	2**
23	N/A	N/A	M4 by 12 Long BHCS	2**
24	N/A	N/A	M4 by 50 Long SHCS	2**
25	N/A	N/A	M5 by 12 Long SHCS	1**
26	N/A	N/A	#10-32 by 3/8" Long Flat Point SSS	1**
27	N/A	N/A	#10-32 Hex Jam Nut	1**
** Available from an industrial supply company such as MSC (1-800-645-7270).				

NOTES

1. Molex recommends an extra perishable tooling kit be maintained at your facility.
2. Verify tooling alignment by manually cycling the press and Applicator before crimping under power. Check that all screws are tight.
3. Slugs, Terminals, Dirt and Oil should be kept clear of work area.
4. Wear safety glasses at all times.
5. For recommended maintenance refer to the FineAdjust Manual.

CAUTION: This applicator should only be used in a press with a shut height of 135.8 mm (5.346"). Tooling damage could result at a lower setting.

CAUTION: To prevent injury never operate this Applicator without the guards supplied with the press or wire-processing machine in place. Reference the press or wire processing manufacturer's instruction manual.

CAUTION: Molex crimp specifications are valid only when used with Molex terminals, applicators and tooling.

Americas Headquarters
Lisle, Illinois 60532 U.S.A.
1-800-78MOLEX
amerinfo@molex.com

Far East North Headquarters
Yamato, Kanagawa, Japan
81-462-65-2324
feninfo@molex.com

Far East South Headquarters
Jurong, Singapore
65-6-268-6868
fesinfo@molex.com

European Headquarters
Munich, Germany
49-89-413092-0
eurinfo@molex.com

Corporate Headquarters
2222 Wellington Ct.
Lisle, IL 60532 U.S.A.
630-969-4550
Fax: 630-969-1352

Visit our Web site at <http://www.molex.com>