

### CONNECTOR-SPECIFIC KIT 679235-1

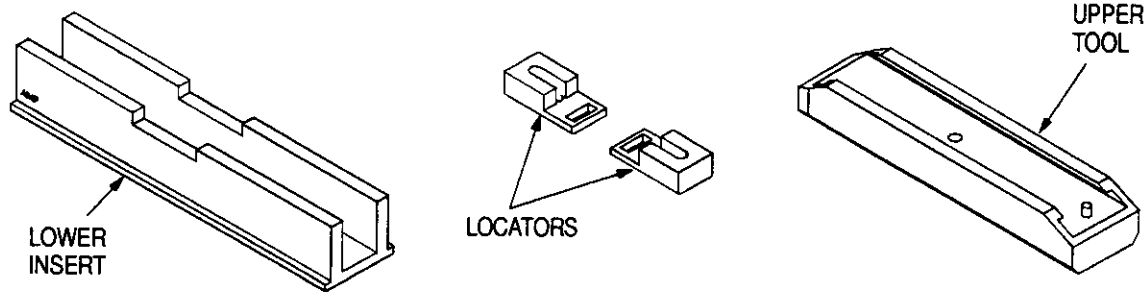

### TYPICAL APPLICATION TOOLING

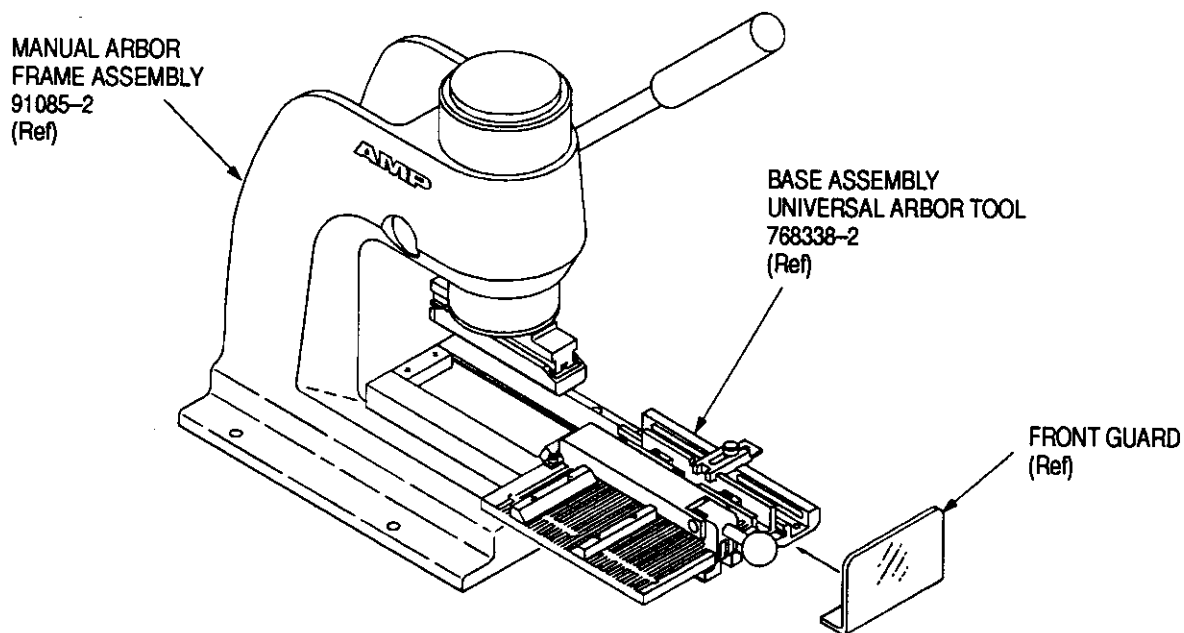

Figure 1

## 1. INTRODUCTION

This instruction sheet covers the installation and setup procedures for AMP Connector-Specific Kit 679235-1. The connector-specific kit is used in conjunction with Base Assembly Universal Arbor Tool 768338-2 and AMP Manual Arbor Frame Assembly 91085-2 (see Figure 1), or AMP Pneumatic Auto-Cycle Unit 91112-3 to terminate AMPLIMITE .050 Series Plug and Receptacle Connectors to 0.64 [.025] centerline flat ribbon cable.

Refer to instruction sheets 408-7777 (supplied with Manual Arbor Frame Assembly) and 408-6732 (supplied with Pneumatic Auto-Cycle Unit) for tooling information. Installation and termination procedures

for the Base Assembly Universal Arbor Tool are available in 408-9875.

#### NOTE

*Dimensions are in millimeters [followed by inch equivalents in brackets].*

Reasons for reissue are provided in Section 6, REVISION SUMMARY.

## 2. DESCRIPTION (Figure 1)

The connector-specific kit features an upper tool, a lower insert, and two locators. The upper tool is secured to the upper tool mount and applies an even force over the length of the connector during termination. The lower insert and locators properly align the connector for termination.

### 3. CABLE REQUIREMENTS

The connector-specific kit will terminate 0.64 [.025] centerline flat ribbon cable with solid or seven-strand 30 AWG cable conductors to AMPLIMITE .050 Series Plug and Receptacle Connectors. Refer to AMP Application Specification 114-40049 for recommended cable dimensions.

#### CAUTION

*The cable must be cut 90° to the edge of the cable; otherwise an improper termination may result. AMP suggests using a guillotine-type cable cutter, such as the Carpenter Model 95 which can be purchased from:*

*Carpenter Manufacturing Co., Inc.  
Fairgrounds Drive  
Manlius, NY 13207*

### 4. INSTALLATION AND SETUP OF CONNECTOR-SPECIFIC KIT

#### 4.1. Installation

These procedures are typical for the Manual Arbor Frame Assembly and the Pneumatic Auto-Cycle Unit. Before installing the connector-specific kit, install the Base Assembly Universal Arbor Tool onto the frame assembly, as described in 408-9875.

#### DANGER

*When using the Pneumatic Auto-Cycle Unit, DISCONNECT air from main air valve.*

1. Slide upper tool onto upper tool mount, as shown in Figure 2.
2. Slide lower insert into the slot of the lower tooling assembly. Using a 0.38 [.015] feeler gage, center the lower insert in the slot. Insert the gage into the slot and position it against the pin. Slide the lower insert into the slot until it is positioned against the gage. When the lower insert is properly positioned, secure it with the two setscrews. See Figure 2.
3. Install the locators onto the tooling and secure them with the flat washers and socket head cap screws, just enough to hold them in place. See Figure 2.

#### 4.2. Setup

1. Open cable clamp assembly.
2. Slide cable through the connector; then insert connector (cover up) into the lower insert and between the locators. See Figure 3.
3. Position cable into the flutes of the fluted plate. The cable conductors must stay in the same flutes for the entire length of the fluted plate.

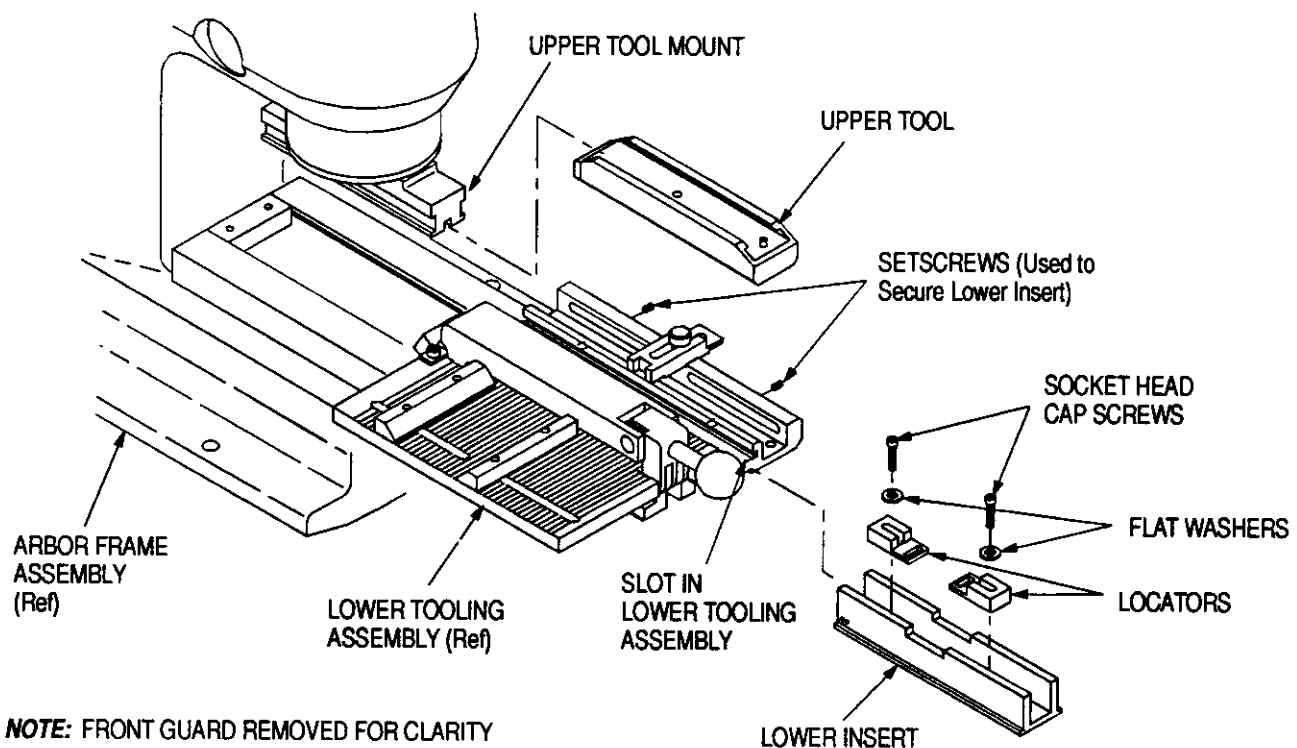

Figure 2

4. Slide locators against the connector; then secure the locators with the socket head cap screws. The front metal shell of the connector must fit securely between the lower level of the locators, as shown in Figure 3.

**NOTE**

*When terminating receptacle connectors with latches, the latches must go through the openings in the locators and sit in the recesses on the bottom of the lower insert. See Figure 3.*

5. Slide cable guide (located on the side of the cable with the registration mark) against the cable and secure it with the thumbscrew. Slide the other cable guide against the cable and secure it with the thumbscrew. See Figure 3.

**DANGER**

*Re-install the front guard on the frame assembly before terminating any connectors. When using the Pneumatic Auto-Cycle Unit, reconnect the air supply to the main air valve.*

6. Perform a test termination and inspect the connector to ensure that the cable conductors are aligned with the contacts. If available, use a tester to inspect the termination, or remove the connector cover and inspect the termination with a microscope. Refer to 408-9875 for termination procedures and Application Specification 114-40049 for termination height dimensions.

7. If the cable conductors are not aligned with the contacts, a re-alignment of the connector is necessary. Using a feeler gage, check the distance between the lower insert and the pin. Refer to Paragraph 4.1, Step 2. Determine the direction the connector must be moved to align the cable conductors with the contacts. Loosen the two setscrews (which secure the lower insert) and re-align the lower insert. Repeat Steps 6 and 7 until the proper termination is attained.

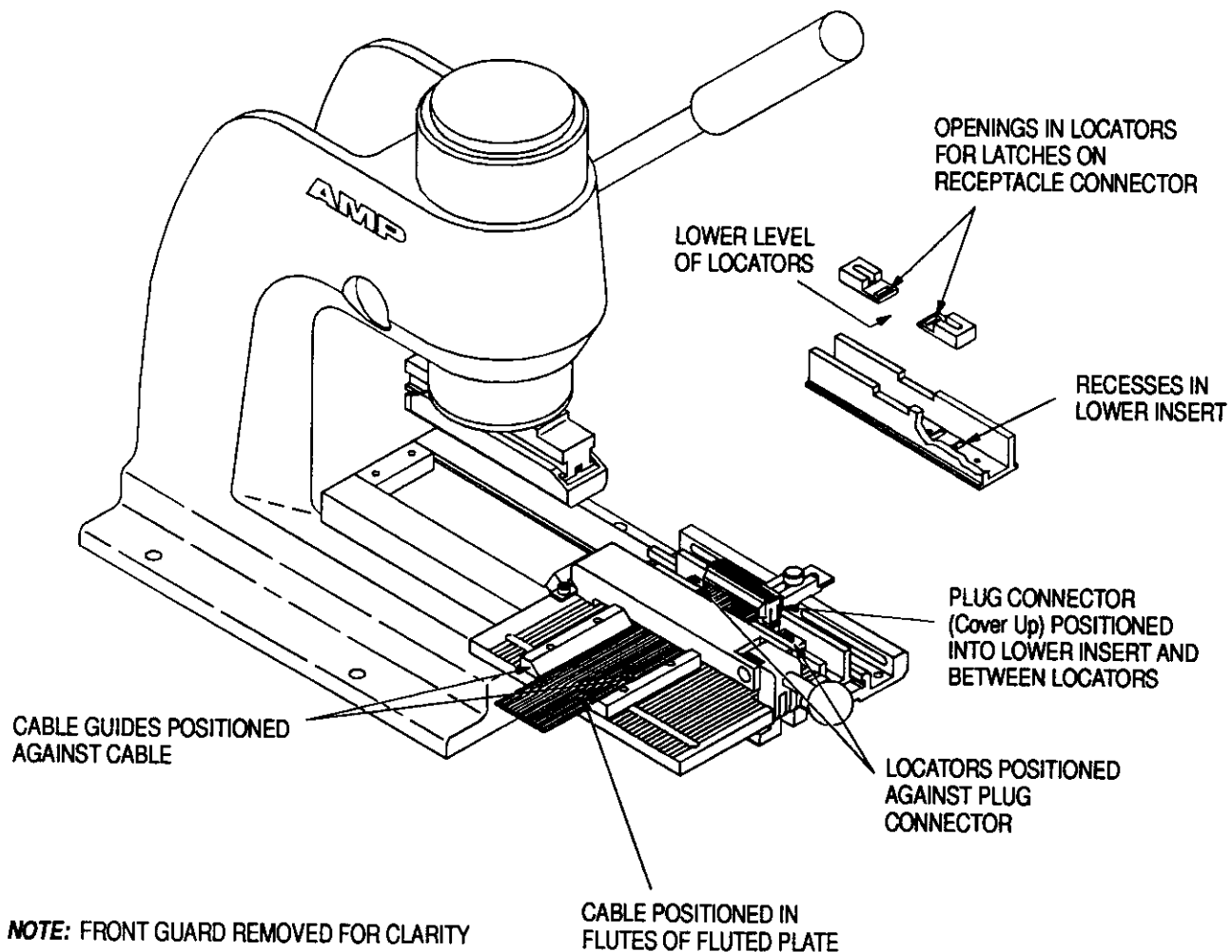

Figure 3

**5. CONNECTOR-SPECIFIC KIT INSPECTION**

Connector-Specific Kit 679235-1 has been inspected and should be verified with the information provided in Figure 4. AMP recommends that the kit be inspected immediately upon its arrival at your facility (and at regularly scheduled intervals) to ensure that the kit components have not been damaged during handling.

For additional information concerning connector-specific kits, or to purchase additional kits, contact your local AMP representative or:

CUSTOMER SERVICE (38-35)  
AMP INCORPORATED  
P.O. BOX 3608  
HARRISBURG, PA 17105-3608

**6. REVISION SUMMARY**

Revisions to this document include:

Per EC 0150-3244-94:

- Removed Figure 2 in Section 3 and renumbered all figures thereafter
- Added reference to Application Specification 114-40049 to Section 3
- Modified illustration of lower insert and locators in Figures 1, 2, 3, and 4
- Removed information from Paragraph 4.1, Step 3
- Removed NOTE from Paragraph 4.2, Step 3
- Added NOTE and information to Paragraph 4.2, Step 4
- Added Flat Washer 21055-4 to Figures 2 and 4
- Removed callouts for position locator from Figures 2 and 3
- Added callout for openings for latches of receptacle connector in locator to Figure 3
- Changed dimensions of lower insert and locator in Figure 4

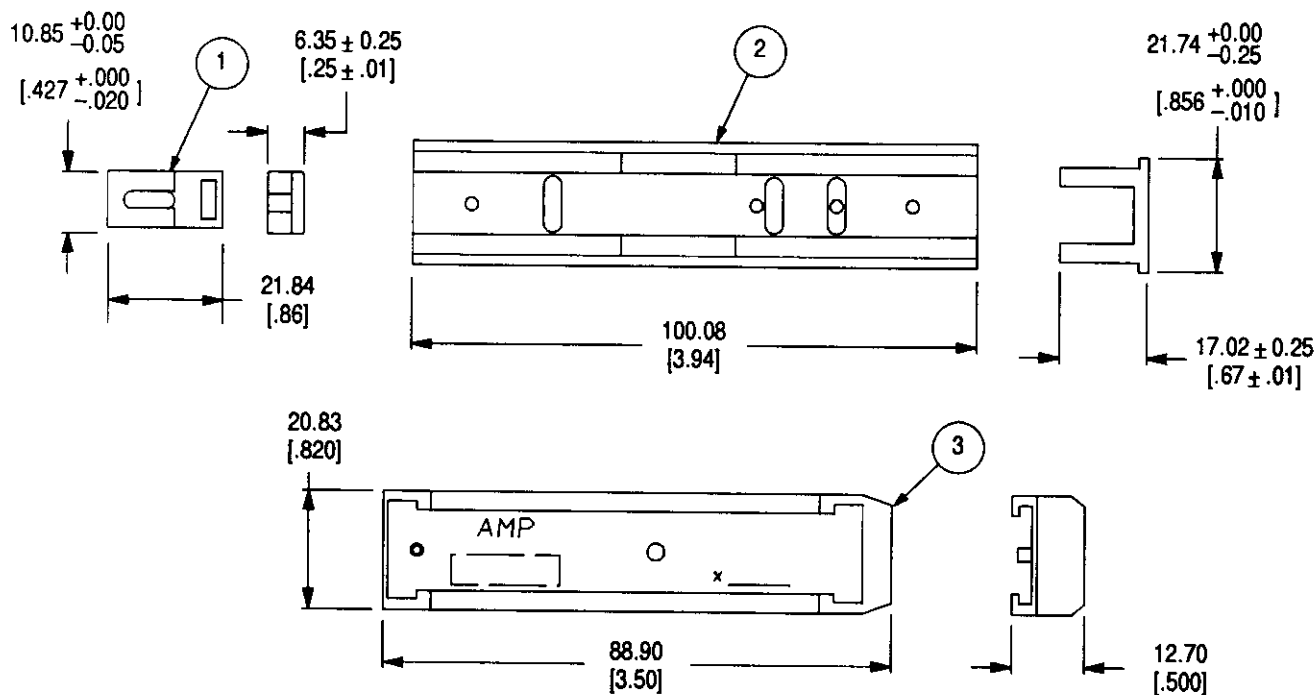

CONNECTOR-SPECIFIC KIT 679235-1			
ITEM NO.	PART NUMBER	DESCRIPTION	QTY
1	679072-1	LOCATOR	2
2	679071-1	INSERT, LOWER	1
3	679100-1	UPPER TOOL	1
(Not Shown)	1-21000-4	SOCKET HEAD CAP SCREWS, 4-40 x .38 Long	2
(Not Shown)	21055-4	FLAT WASHER, No. 4	2

Figure 4