

## Features

- Using external 32.768kHz quartz crystal for PT7C4337A
- Using internal 32.768kHz quartz crystal for PT7C4337AC
- Supports I<sup>2</sup>C-Bus's high speed mode (400 kHz)
- Includes time (Hour/Minute/Second) and calendar (Year/Month/Date/Day) counter functions (BCD code)
- Programmable square wave output signal
- Two Time-of-Day Alarms
- Oscillator Stop Flag
- Operating range: 1.8V to 5.5V
- Timekeeping range: 1.2V to 1.8V
- Totally Lead-Free & Fully RoHS Compliant (Notes 1 & 2)
- Halogen and Antimony Free. "Green" Device (Note 3)
- For automotive applications requiring specific change control (i.e. parts qualified to AEC-Q100/101/200, PPAP capable, and manufactured in IATF 16949 certified facilities), please [contact us](mailto:contact_us) or your local Diodes representative.  
<https://www.diodes.com/quality/product-definitions/>
- Packaging
  - 8-Pin, SOIC (W)
  - 8-Pin, MSOP (U)
  - 8-Pin, TSSOP (L)
  - 16-Pin, SOIC (S)

## Description

The PT7C4337A/4337AC serial real-time clock is a low-power clock/calendar with two programmable time-of-day alarms and a programmable square-wave output.

Address and data are transferred serially via a 2-wire, bidirectional bus. The clock/calendar provides seconds, minutes, hours, day, date, month, and year information. The date at the end of the month is automatically adjusted for months with fewer than 31 days, including corrections for leap year. The clock operates in either the 24-hour or 12-hour format with AM/PM indicator.

The device is fully accessible through the serial interface while VCC is between 1.8V and 5.5V. I2C operation is not guaranteed below 1.8V. Timekeeping operation is maintained with VCC as low as 1.2V.

Table 1 shows the basic functions of PT7C4337A/ 4337AC. More details are shown in section: overview of functions.

**Table 1. Basic functions of PT7C4337A/4337AC**

Item	Function	PT7C4337A	PT7C4337AC
1	Oscillator	Source	Crystal(32.768KHz)
		Oscillator enable/disable	External crystal
		Oscillator fail detect	Integrated Crystal
2	Time display	12-hour	√
		24-hour	√
	Century bit	√	√
	Time count chain enable/disable	√	√
3	Interrupt	Alarm interrupt output	√ 2
4	Programmable square wave output (Hz)	1, 4.096k, 8.192k, 32.768k	1, 4.096k, 8.192k, 32.768k
5	Communication	2-wire I <sup>2</sup> C bus	√

Notes:  
 1. No purposely added lead. Fully EU Directive 2002/95/EC (RoHS), 2011/65/EU (RoHS 2) & 2015/863/EU (RoHS 3) compliant.  
 2. See <https://www.diodes.com/quality/lead-free/> for more information about Diodes Incorporated's definitions of Halogen- and Antimony-free, "Green" and Lead-free.  
 3. Halogen- and Antimony-free "Green" products are defined as those which contain <900ppm bromine, <900ppm chlorine (<1500ppm total Br + Cl) and <1000ppm antimony compounds.

## Pin Configuration

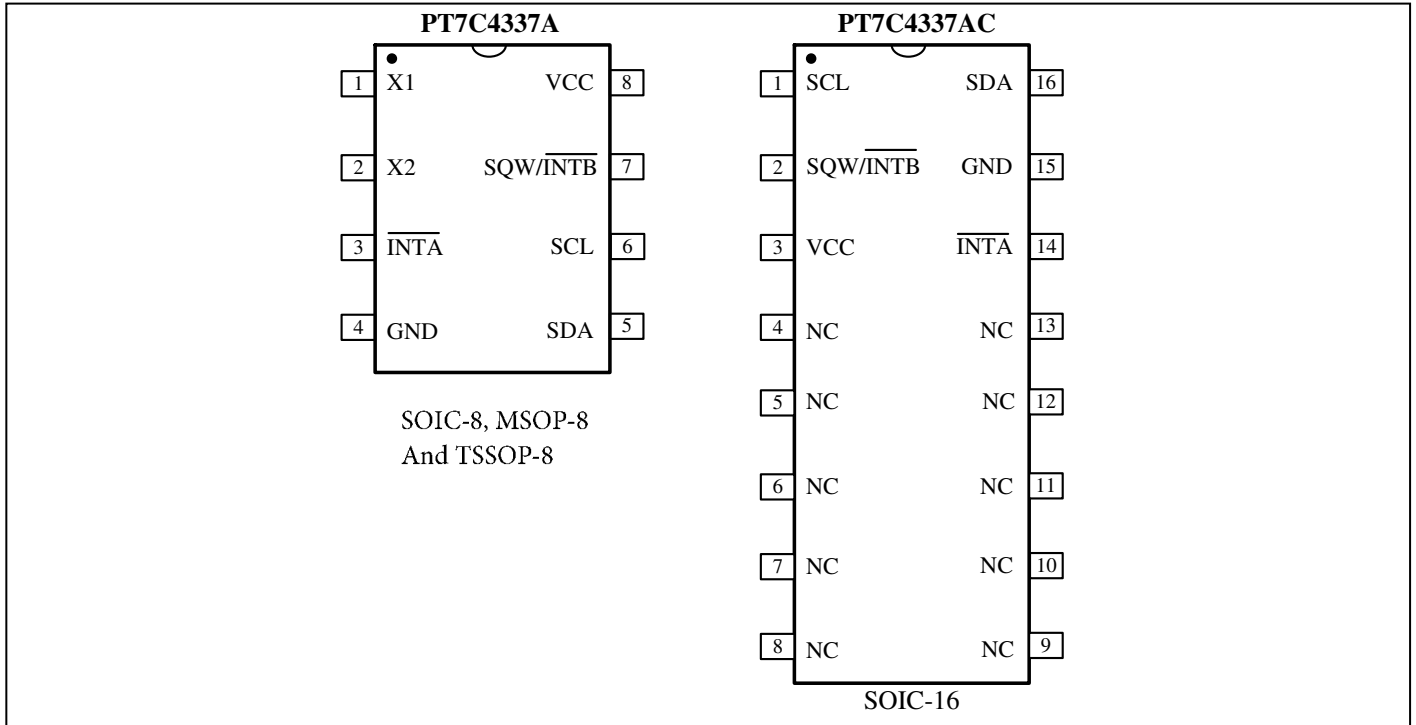

## Pin Description

4337A Pin#	4337AC SOIC Pin#	Pin	Type	Description
1	/	X1	I	<b>Oscillator Circuit Input.</b> Together with X1, 32.768kHz crystal is connected between them. Or external clock input.
2	/	X2	O	<b>Oscillator Circuit Output.</b> Together with X1, 32.768kHz crystal is connected between them. When 32.768kHz external input, X2 must be float.
6	1	SCL	I	<b>Serial Clock Input.</b> SCL is used to synchronize data movement on the I <sup>2</sup> C serial interface.
5	16	SDA	I/O	<b>Serial Data Input/Output.</b> SDA is the input/output pin for the 2-wire serial interface. The SDA pin is open-drain output and requires an external pull-up resistor.
3	14	$\overline{\text{INTA}}$	O	<b>Interrupt Output.</b> When enabled, $\overline{\text{INTA}}$ is asserted low when the time matches the values set in the alarm registers. This pin is an open-drain output and requires an external pull up resistor.
7	2	$\overline{\text{SQW/INTB}}$	O	<b>Square-Wave/Interrupt Output.</b> Programmable square-wave or interrupt output signal. It is an open-drain output and requires an external pull up resistor.
8	3	VCC	P	<b>Power.</b> Primary power for PT7C4337A.
4	15	GND	P	<b>Ground.</b>
/	5-13	NC		<b>No Connect.</b> These pins are not connected internally, but must be grounded for proper operation.

## Maximum Ratings

Storage Temperature .....	-65°C to +150°C
Supply Voltage to Ground Potential ( $V_{CC}$ to GND) .....	-0.3V to +6.5V
DC Input (All Other Inputs except $V_{CC}$ & GND) .....	-0.3V to ( $V_{CC}+0.3V$ )
DC Output Voltage (SDA, /INTA, /INTB pins) .....	-0.3V to +6.5V
DC Output Current (FOUT) .....	-0.3V to ( $V_{CC}+0.3V$ )
Power Dissipation .....	320mW (depend on package)
Junction Temperature .....	125°C max

### Note:

Stresses greater than those listed under MAXIMUM RATINGS may cause permanent damage to the device. This is a stress rating only and functional operation of the device at these or any other conditions above those indicated in the operational sections of this specification is not implied. Exposure to absolute maximum rating conditions for extended periods may affect reliability.

## Operating Mode

The amount of current consumed by the PT7C4337A is determined, in part, by the I<sup>2</sup>C interface and oscillator operation. The following table shows the relationship between the operating mode and the corresponding  $I_{CC}$  parameter.

Operating Mode	$V_{CC}$	Power
I <sup>2</sup> C Interface Active	$1.8V \leq V_{CC} \leq 5.5V$	$I_{CC}$ Active ( $I_{CCA}$ )
I <sup>2</sup> C Interface Inactive	$1.8V \leq V_{CC} \leq 5.5V$	$I_{CC}$ Standby ( $I_{CCS}$ )
I <sup>2</sup> C Interface Inactive	$1.2V \leq V_{CC} \leq 1.8V$	Timekeeping ( $I_{CCTOSC}$ )
I <sup>2</sup> C Interface Inactive, Oscillator Disabled	$1.2V \leq V_{CC} \leq 1.8V$	Data Retention ( $I_{CCTDDR}$ )

## Recommended Operating Conditions

Part No.	Sym.	Description	Min	Type	Max	Unit	
PT7C4337A PT7C4337AC	$V_{CC}$	$V_{CC}$ supply voltage	1.8	3.3	5.5	V	
	$V_{CCT}$		1.2	-	1.8		
	$V_{OSC}$	Oscillator start up voltage	1.2	-	5.5		
	$V_{IH}$	Input high level	SCL, SDA	$0.7V_{CC}$	-		$V_{CC}+0.3$
			$\overline{INTA}$ , $SQW/\overline{INTB}$	-	-		5.5
	$V_{IL}$	Input low level	-0.3	-	$0.3V_{CC}$		
	$T_A$	Operating temperature	-40	-	85	°C	

## DC Electrical Characteristics

Unless otherwise specified,  $V_{CC} = 1.8\sim 5.5V$ ,  $T_A = -40\text{ }^\circ\text{C}$  to  $+85\text{ }^\circ\text{C}$

Sym.	Item	Pin	Condition	Min	Typ	Max	Unit
$V_{CC}$	Supply voltage	$V_{CC}$	Full operation	1.8	-	5.5	V
$V_{CCT}$			Timekeeping (Note 5)	1.2	-	1.8	
$V_{OSC}$	Oscillator voltage	$V_{CC}$		1.2	-	5.5	V
$V_{IL1}$	Low-level input voltage	SCL		-0.3	-	$0.3V_{CC}$	V
$V_{IH1}$	High-level input voltage	SCL		$0.7V_{CC}$	-	$V_{CC}+0.3$	
$V_{IL2}$	Low-level input voltage	X1		-	0.53	-	V
$V_{IH2}$	High-level input voltage	X1		-	0.53	-	
$I_{OL}$	Low-level output current	SDA, /INTA, /INTB	$V_{OL} = 0.4V$	3	-	-	mA
$I_{IL}$	Input leakage current	SCL		-1	-	1	$\mu\text{A}$
$I_{OZ}$	Output current when OFF	SDA, /INTA, /INTB		-1	-	1	$\mu\text{A}$

## DC Electrical Characteristics

Sym.	Item	Pin	Condition	Min	Typ	Max	Unit
Unless otherwise specified, $V_{CC} = 1.3\sim 1.8V$ , $T_A = -40\text{ }^\circ\text{C}$ to $+85\text{ }^\circ\text{C}$							
$I_{CCTOSC}$	Timekeeping current	$V_{CC}$	Note 2, 4, 5	-	450	800	nA
$I_{CCTDDR}$	Data retention current	$V_{CC}$	Note 2,4,5,6	-	-	160	
Unless otherwise specified, $V_{CC} = 1.8\sim 3.6V$ , $T_A = -40\text{ }^\circ\text{C}$ to $+85\text{ }^\circ\text{C}$							
$I_{CCA}$	Active supply current	$V_{CC}$	Note 1, 5	-	-	100	$\mu\text{A}$
$I_{CCS}$	Standby current	$V_{CC}$	Note 2, 3, 5	-	0.6	1.0	
Unless otherwise specified, $V_{CC} = 3.6\sim 5.5V$ , $T_A = -40\text{ }^\circ\text{C}$ to $+85\text{ }^\circ\text{C}$							
$I_{CCA}$	Active supply current	$V_{CC}$	Note 1, 5	-	-	150	$\mu\text{A}$
$I_{CCS}$	Standby current	$V_{CC}$	Note 2, 3, 5	-	1.0	1.8	

*Note:*

- SCL clocking at max frequency = 400kHz,  $V_{IL} = 0.0V$ ,  $V_{IH} = V_{CC}$ .
- Specified with 2-wire bus inactive,  $V_{IL} = 0.0V$ ,  $V_{IH} = V_{CC}$ .
- SQW enabled.
- Specified with the SQW function disabled by setting INTCN = 1.
- Using recommended crystal on X1 and X2.
- Crystal oscillator is disabled.

## Frequency Characteristics

### PT4337AC

Sym.	Description	Condition	Rating	Unit
$\Delta f / f$	Frequency tolerance	$T_A = +25\text{ }^\circ\text{C}$ $V_{DD} = 3.3\text{ V}$	Stability AC: $0 \pm 30$	$\times 10^{-6}$
$f / V$	Frequency voltage characteristics	$T_A = +25\text{ }^\circ\text{C}$ $V_{DD} = 2\text{ V to } 5\text{ V}$	$\pm 2\text{ Max.}$	$\times 10^{-6} / \text{V}$
Top	Frequency temperature characteristics	$T_A = -10\text{ }^\circ\text{C}$ to $+70\text{ }^\circ\text{C}$ , $V_{DD} = 3.3\text{ V}$ ; $+25\text{ }^\circ\text{C}$ reference	$+10 / -120$	$\times 10^{-6}$
$t_{STA}$	Oscillation start up time	$T_A = +25\text{ }^\circ\text{C}$ $V_{DD} = 3.3\text{ V}$	3 Max.	s
fa	Aging	$T_A = +25\text{ }^\circ\text{C}$ $V_{DD} = 3.0\text{ V}$ ; first year	$\pm 5\text{ Max.}$	$\times 10^{-6} / \text{year}$

**Recommended Layout for Crystal (Only for PT7C4337A)**

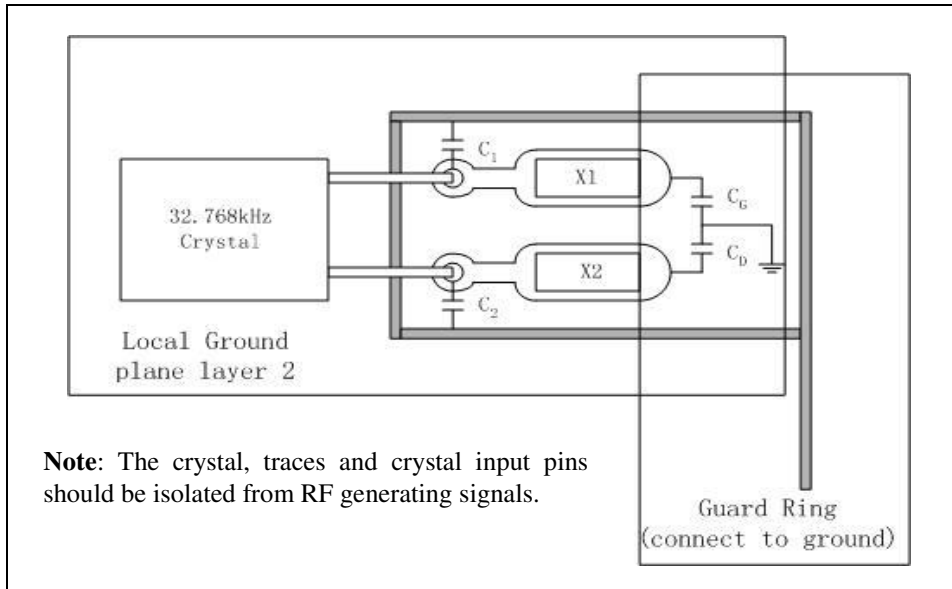

**Built-in Capacitors Specifications and Recommended External Capacitors**

Parameter		Symbol	Typ	Unit
Build-in capacitors	X1 to GND	C <sub>G</sub>	12	pF
	X2 to GND	C <sub>D</sub>	12	pF
Recommended External capacitors for crystal C <sub>L</sub> =12.5pF	X1 to GND	C <sub>1</sub>	12	pF
	X2 to GND	C <sub>2</sub>	12	pF
Recommended External capacitors for crystal C <sub>L</sub> =6pF	X1 to GND	C <sub>1</sub>	0	pF
	X2 to GND	C <sub>2</sub>	0	pF

**Note:** The frequency of crystal can be optimized by external capacitor C<sub>1</sub> and C<sub>2</sub>, for frequency=32.768KHz, C<sub>1</sub> and C<sub>2</sub> should meet the equation as below:

$$C_{par} + [(C_1 + C_G) * (C_2 + C_D)] / [(C_1 + C_G) + (C_2 + C_D)] = C_L$$

**C<sub>par</sub> is all parasitical capacitor between X1 and X2.**

C<sub>L</sub> is crystal's load capacitance.

**Crystal Specifications**

Parameter	Symbol	Min	Typ	Max	Unit
Nominal Frequency	f <sub>0</sub>	-	32.768	-	kHz
Series Resistance	ESR	-	-	70	kΩ
Load Capacitance	C <sub>L</sub>	-	6/12.5	-	pF

**AC Electrical Characteristics**

Sym	Description	Value	Unit
V <sub>HM</sub>	Rising and falling threshold voltage high	0.8 V <sub>CC</sub>	V
V <sub>LM</sub>	Rising and falling threshold voltage low	0.2 V <sub>CC</sub>	V

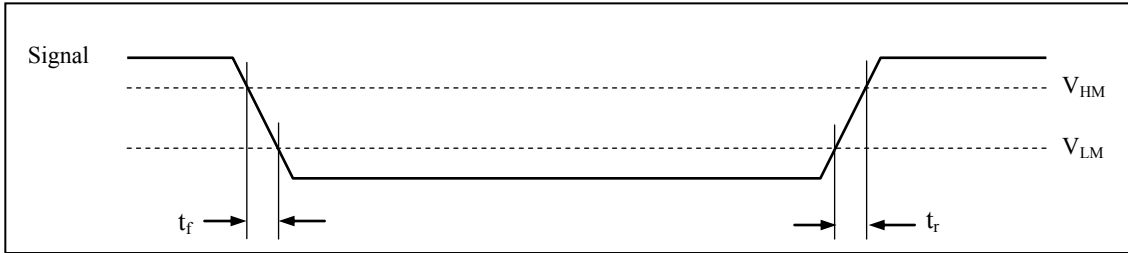

Over the operating range

Symbol	Item	Min.	Typ.	Max.	Unit
f <sub>SCL</sub>	SCL clock frequency	-	-	400	kHz
t <sub>SU:STA</sub>	START condition set-up time	0.6	-	-	μs
t <sub>HD:STA</sub>	START condition hold time	0.6	-	-	μs
t <sub>SU:DAT</sub>	Data set-up time (RTC read/write)	200	-	-	ns
t <sub>HD:DAT1</sub>	Data hold time (RTC write)	35	-	-	ns
t <sub>HD:DAT2</sub>	Data hold time (RTC read)	0	-	-	μs
t <sub>SU:STO</sub>	STOP condition setup time	0.6	-	-	μs
t <sub>BUF</sub>	Bus idle time between a START and STOP condition	1.3	-	-	μs
t <sub>LOW</sub>	When SCL = "L"	1.3	-	-	μs
t <sub>HIGH</sub>	When SCL = "H"	0.6	-	-	μs
t <sub>r</sub>	Rise time for SCL and SDA	-	-	0.3	μs
t <sub>f</sub>	Fall time for SCL and SDA	-	-	0.3	μs
t <sub>SP</sub> *	Allowable spike time on bus	-	-	50	ns
C <sub>B</sub>	Capacitance load for each bus line	-	-	400	pF
C <sub>I/O</sub> *	I/O Capacitance (SDA, SCL)	-	-	10	pF
T <sub>OSF</sub>	Oscillator Stop Flag (OSF) Delay	-	-	100	ms

\* Note: only reference for design

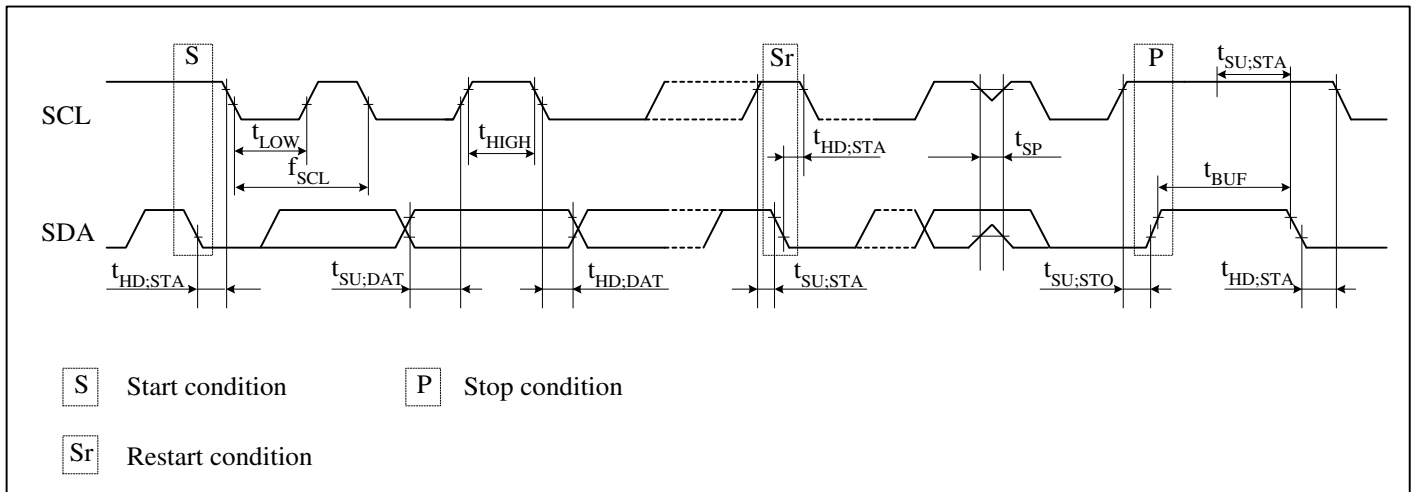

## Function Block

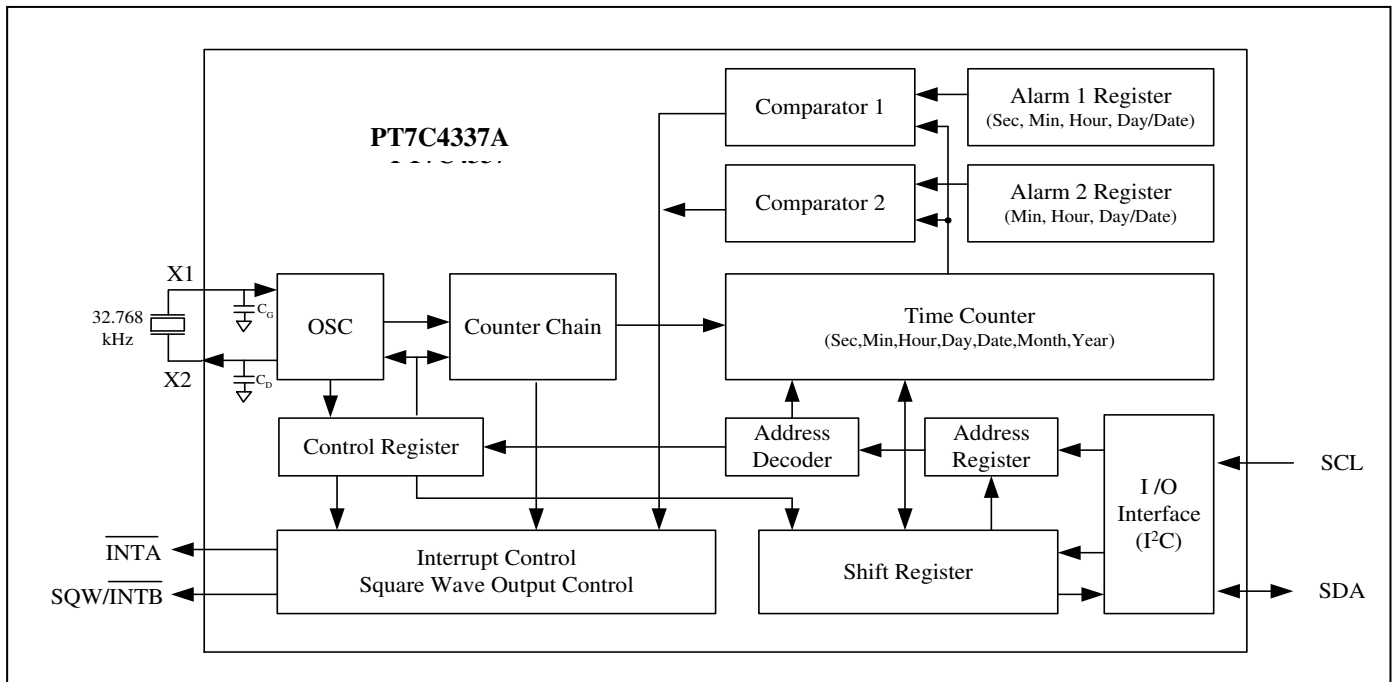

## Oscillator Circuit

### PT7C4337A

The PT7C4337A uses an external 32.768 kHz crystal. Table 2 specifies several crystal parameters for the external crystal. The *Block Diagram* shows a functional schematic of the oscillator circuit. The startup time is usually less than 1 second when using a crystal with the specified characteristics.

**Table 2. Crystal Specifications**

Parameter	Symbol	Min	Typ	Max	Unit
Nominal Frequency	$f_0$	-	32.768	-	kHz
Series Resistance	ESR	-	-	70	k $\Omega$
Load Capacitance	$C_L$	-	6/12.5	-	pF

*Note: The crystal, traces, and crystal input pins should be isolated from RF generating signals.*

## Clock Accuracy

The accuracy of the clock is dependent upon the accuracy of the crystal and the accuracy of the match between the capacitive load of the oscillator circuit and the capacitive load for which the crystal was trimmed. Crystal frequency drift caused by temperature shifts creates additional error. External circuit noise coupled into the oscillator circuit can result in the clock running fast. Figure 1 shows a typical PC board layout for isolating the crystal and oscillator from noise.

### PT7C4337AC

The PT7C4337AC integrates a standard 32,768Hz crystal in the package. Typical accuracy at nominal VCC and +25°C is approximately  $\pm 10$ ppm.

## Function Description

### Overview of Functions

#### Clock Function

CPU can read or write data including the year (last two digits), month, date, day, hour, minute, and second. Any (two-digit) year that is a multiple of 4 is treated as a leap year and calculated automatically as such until the year 2100. On a power-on reset (POR), the time and date are set to 00:00:00 01/01/00 (hh:mm:ss DD/MM/YY) and the Day register is set to 01.

#### Alarm Function

This device has two alarm system (Alarm 1 and Alarm 2) that outputs interrupt signals from INTA or INTB to CPU when the date, day of the week, hour, minute or second correspond to the setting. Each of them may output interrupt signal separately at a specified time. The alarm is be selectable between on and off for matching alarm or repeating alarm.

#### Programmable Square Wave Output

A square wave output enable bit controls square wave output at pin 7. Frequencies are selectable: 1, 4.096k, 8.192k, 32.768k Hz.

#### Interface with CPU

Data is read and written via the I<sup>2</sup>C bus interface using two signal lines: SCL (clock) and SDA (data).

Since the output of the I/O pin SDA is open drain, a pull-up resistor should be used on the circuit board if the CPU output I/O is also open drain.

The SCL's maximum clock frequency is 400 kHz, which supports the I<sup>2</sup>C bus's high-speed mode.

#### Oscillator Fail Detect

When oscillator fail, PT7C4337A OSF bit will be set.

#### Oscillator Enable/Disable

Oscillator and time count chain can be enabled or disabled at the same time by /ETIME bit.

## Registers

Allocation of registers

Addr. (hex) <sup>*1</sup>	Function	Register definition							
		Bit 7	Bit 6	Bit 5	Bit 4	Bit 3	Bit 2	Bit 1	Bit 0
00	Seconds (00-59)	0	S40	S20	S10	S8	S4	S2	S1
01	Minutes (00-59)	0	M40	M20	M10	M8	M4	M2	M1
02	Hours (00-23 / 01-12)	0	12, /24	H20 or P, /A	H10	H8	H4	H2	H1
03	Days of the week (01-07)	0	0	0	0	0	W4	W2	W1
04	Dates (01-31)	0	0	D20	D10	D8	D4	D2	D1
05	Months (01-12)	Century	0	0	MO10	MO8	MO4	MO2	MO1
06	Years (00-99)	Y80	Y40	Y20	Y10	Y8	Y4	Y2	Y1
07	Alarm 1: Seconds	A1M1 <sup>*2</sup>	S40	S20	S10	S8	S4	S2	S1
08	Alarm 1: Minutes	A1M2 <sup>*2</sup>	M40	M20	M10	M8	M4	M2	M1
09	Alarm 1: Hours	A1M3 <sup>*2</sup>	12, /24	H20 or P, /A	H10	H8	H4	H2	H1
0A	Alarm 1: Day, Date	A1M4 <sup>*2</sup>	Day, /Date	0, D20	0, D10	0, D8	W4, D4	W2, D2	W1, D1
0B	Alarm 2: Minutes	A2M2 <sup>*3</sup>	M40	M20	M10	M8	M4	M2	M1
0C	Alarm 2: Hours	A2M3 <sup>*3</sup>	12, /24	H20 or P, /A	H10	H8	H4	H2	H1



Addr. (hex) <sup>*1</sup>	Function	Register definition							
		Bit 7	Bit 6	Bit 5	Bit 4	Bit 3	Bit 2	Bit 1	Bit 0
0D	Alarm 2: Day, Date	A2M4 <sup>*3</sup>	Day, /Date	0, D20	0, D10	0, D8	W4, D4	W2, D2	W1, D1
0E	Control	/ETIME <sup>*4</sup>	0	0	RS2 <sup>*5</sup>	RS1 <sup>*5</sup>	INTCN <sup>*6</sup>	A2IE <sup>*7</sup>	A1IE <sup>*7</sup>
0F	Status	OSF <sup>*9</sup>	0	0	0	0	0	A2F <sup>*8</sup>	A1F <sup>*8</sup>

Caution points:

- \*1. PT7C4337A uses 8 bits for address. For excess 0FH address, PT7C4337A will not respond (no acknowledge signal was given).
- \*2. Alarm 1 mask bits. Select alarm repeated rate when an alarm occurs.
- \*3. Alarm 2 mask bits. Select alarm repeated rate when an alarm occurs.
- \*4. Oscillator and time count chain enable/disable bit.
- \*5. Square wave output frequency select.
- \*6. Interrupt output pin select bit.
- \*7. Alarm 1 and alarm 2 enable bits.
- \*8. Alarm 1 and alarm 2 flag bits.
- \*9. Oscillator stops flag.
- \*10. All bits marked with "0" are read-only bits. Their value when read is always "0".

### Control and Status Register

Addr. (hex)	Description	D7	D6	D5	D4	D3	D2	D1	D0
0E	Control	/ETIME	0	0	RS2	RS1	INTCN	A2IE	A1IE
	(default)	0	0	0	1	1	0	0	0
0F	Status	OSF	0	0	0	0	0	A2F	A1F
	(default)	1	0	0	0	0	0	Undefined	Undefined

### Oscillator Related Bits

- **/ETIME**

Enable oscillator and time count chain bit.

/ETIME	Data	Description
Read / Write	0	Enable oscillator and time count chain. <span style="float: right;">Default</span>
	1	Disable oscillator and time count chain.

- **OSF**

Oscillator Stops Flag.

A logic 1 in this bit indicates that the oscillator either is stopped or was stopped for some period of time and may be used to judge the validity of the clock and calendar data. This bit is set to logic 1 anytime that the oscillator stops. The following are examples of conditions that can cause the OSF bit to be set:

- 1) The first time power is applied.
- 2) The voltage present on VCC is insufficient to support oscillation.
- 3) The /ETIME bit is turned off.
- 4) External influences on the crystal (e.g., noise, leakage, etc.).

This bit remains at logic 1 until written to logic 0.

### Square Wave Frequency Selection Bits

- **RS2, RS1**

Square wave Rate Select. These bits control the frequency of the square-wave output when the square wave has been enabled.

RS2, RS1	Data	SQW output freq. (Hz)
Read / Write	00	1
	01	4.096k
	10	8.192k
	11	32.768k

### Interrupt Related Bits

- **INTCN**

Interrupt Output pin select bit. This bit controls the relationship between the two alarms and the interrupt output pins.

INTCN	Data	Description
Read / Write	1	A match between the timekeeping registers and the alarm 1 registers activates the $\overline{\text{INTA}}$ pin (if the alarm 1 is <u>enabled</u> ) and a match between the timekeeping registers and the alarm 2 registers activates the SQW/INTB pin (if the alarm 2 is enabled).
	0	A match between the timekeeping registers and either alarm 1 or alarm 2 registers activates the $\overline{\text{INTA}}$ pin (if the alarms are enabled). In this configuration, a square wave is output on the SQW/INTB pin. <span style="float: right;">Default</span>

- **A1IE**

Alarm 1 Interrupt Enable.

A1IE	Data	Description
Read / Write	0	The A1F bit does not initiate the $\overline{\text{INTA}}$ signal. <span style="float: right;">Default</span>
	1	Permits the alarm 1 flag (A1F) bit in the status register to assert $\overline{\text{INTA}}$ .

- **A1F**

Alarm 1 Flag.

A1F	Data	Description
Read / Write	0	The time do not match the alarm 1 registers. <span style="float: right;">Default</span>
Read	1	Indicates that the time matched the alarm 1 registers. If the A1IE bit is also logic 1, the $\overline{\text{INTA}}$ pin goes low. A1F is cleared when written to logic 0. Attempting to write to logic 1 leaves the value unchanged.

- **A2IE**

Alarm 2 Interrupt Enable.

A2IE	Data	Description
Read / Write	0	The A2F bit does not initiate an interrupt signal. <span style="float: right;">Default</span>
	1	Permits the alarm 2 flag (A2F) bit in the status register to assert $\overline{\text{INTA}}$ (when INTCN = 0) or to assert SQW/INTB (when INTCN = 1).

- A2F**

Alarm 2 Flag.

A1F	Data	Description
Read / Write	0	The time do not match the alarm 2 registers. <span style="float: right;">Default</span>
Read	1	Indicates that the time matched the alarm 1 registers. This flag can be used to generate an interrupt on either $\overline{\text{INTA}}$ or $\text{SQW}/\overline{\text{INTB}}$ depending on the status of the $\text{INTCN}$ bit. If the $\text{INTCN} = 0$ and $\text{A2F} = 1$ (and $\text{A2IE} = 1$ ), the $\overline{\text{INTA}}$ pin goes low. If the $\text{INTCN} = 1$ and $\text{A2F} = 1$ (and $\text{A2IE} = 1$ ), the $\text{SQW}/\overline{\text{INTB}}$ pin goes low. $\text{A2F}$ is cleared when written to logic 0. Attempting to write to logic 1 leaves the value unchanged.

### Time Counter

Time digit display (in BCD code):

- Second digits: Range from 00 to 59 and carried to minute digits when incremented from 59 to 00.
- Minute digits: Range from 00 to 59 and carried to hour digits when incremented from 59 to 00.
- Hour digits: See description on the /12, 24 bit. Carried to day and day-of-the-week digits when incremented from 11 p.m. to 12 a.m. or 23 to 00.

Addr. (hex)	Description	D7	D6	D5	D4	D3	D2	D1	D0
00	Seconds	0	S40	S20	S10	S8	S4	S2	S1
	(default)	0	0	0	0	0	0	0	0
01	Minutes	0	M40	M20	M10	M8	M4	M2	M1
	(default)	0	0	0	0	0	0	0	0
02	Hours	0	12, /24	H20 or P,/A	H10	H8	H4	H2	H1
	(default)	0	0	0	0	0	0	0	0

**Note:** Any registered imaginary time should be replaced with correct time, otherwise it will cause the clock counter malfunction.

- 12, /24 bit**

This bit is used to select between 12-hour clock system and 24-hour clock system.

12, /24	Data	Description
Read / Write	0	24-hour system
	1	12-hour system

This bit is used to select between 12-hour clock operation and 24-hour clock operation.

12, /24	Description	Hours register			
		24-hour clock	12-hour clock	24-hour clock	12-hour clock
0	24-hour time display	00	52 ( AM 12 )	12	72 ( PM 12 )
		01	41 ( AM 01 )	13	61 ( PM 01 )
		02	42 ( AM 02 )	14	62 ( PM 02 )
		03	43 ( AM 03 )	15	63 ( PM 03 )
		04	44 ( AM 04 )	16	64 ( PM 04 )
		05	45 ( AM 05 )	17	65 ( PM 05 )
1	12-hour time display	06	46 ( AM 06 )	18	66 ( PM 06 )
		07	47 ( AM 07 )	19	67 ( PM 07 )
		08	48 ( AM 08 )	20	68 ( PM 08 )
		09	49 ( AM 09 )	21	69 ( PM 09 )
		10	50 ( AM 10 )	22	70 ( PM 10 )
		11	51 ( AM 11 )	23	71 ( PM 11 )

\* Be sure to select between 12-hour and 24-hour clock operation before writing the time data.

### Days of the week Counter

The day counter is a divide-by-7 counter that counts from 01 to 07 and up 07 before starting again from 01. Values that correspond to the day of week are user defined but must be sequential (i.e., if 1 equals Sunday, then 2 equals Monday, and so on). Illogical time and date entries result in undefined operation.

Addr. (hex)	Description	D7	D6	D5	D4	D3	D2	D1	D0
03	Days of the week	0	0	0	0	0	W4	W2	W1
	(default)	0	0	0	0	0	0	0	1

### Calendar Counter

The data format is BCD format.

- Day digits: Range from 1 to 31 (for January, March, May, July, August, October and December).  
Range from 1 to 30 (for April, June, September and November).  
Range from 1 to 29 (for February in leap years).  
Range from 1 to 28 (for February in ordinary years).  
Carried to month digits when cycled to 1.
- Month digits: Range from 1 to 12 and carried to year digits when cycled to 1.
- Year digits: Range from 00 to 99 and 00, 04, 08, ... , 92 and 96 are counted as leap years.

Addr. (hex)	Description	D7	D6	D5	D4	D3	D2	D1	D0
04	Dates	0	0	D20	D10	D8	D4	D2	D1
	(default)	0	0	0	0	0	0	0	1
05	Months	Century <sup>*1</sup>	0	0	M10	M8	M4	M2	M1
	(default)	0	0	0	0	0	0	0	1
06	Years	Y80	Y40	Y20	Y10	Y8	Y4	Y2	Y1
	(default)	0	0	0	0	0	0	0	0

\*1: The century bit is toggled when the years register overflows from 99 to 00.

## Alarm Register

### • Alarm 1, Alarm 2 Register

Addr.	Description	D7	D6	D5	D4	D3	D2	D1	D0
07	Alarm 1: Seconds	A1M1 <sup>*1</sup>	S40	S20	S10	S8	S4	S2	S1
	(default)	Undefined	Undefined	Undefined	Undefined	Undefined	Undefined	Undefined	Undefined
08	Alarm 1: Minutes	A1M2 <sup>*1</sup>	M40	M20	M10	M8	M4	M2	M1
	(default)	Undefined	Undefined	Undefined	Undefined	Undefined	Undefined	Undefined	Undefined
09	Alarm 1: Hours	A1M3 <sup>*1</sup>	12, /24	H20 or P,/A	H10	H8	H4	H2	H1
	(default)	Undefined	Undefined	Undefined	Undefined	Undefined	Undefined	Undefined	Undefined
0A	Alarm 1: Day, Date	A1M4 <sup>*1</sup>	Day, /Date <sup>*1</sup>	0, D20	0, D10	0, D8	W4, D4	W2, D2	W1, D1
	(default)	Undefined	Undefined	Undefined	Undefined	Undefined	Undefined	Undefined	Undefined
0B	Alarm 2: Minutes	A2M2 <sup>*2</sup>	M40	M20	M10	M8	M4	M2	M1
	(default)	Undefined	Undefined	Undefined	Undefined	Undefined	Undefined	Undefined	Undefined
0C	Alarm 2: Hours	A2M3 <sup>*2</sup>	12, /24	H20 or P,/A	H10	H8	H4	H2	H1
	(default)	Undefined	Undefined	Undefined	Undefined	Undefined	Undefined	Undefined	Undefined
0D	Alarm 2: Day, Date	A2M4 <sup>*2</sup>	Day, /Date <sup>*2</sup>	0, D20	0, D10	0, D8	W4, D4	W2, D2	W1, D1
	(default)	Undefined	Undefined	Undefined	Undefined	Undefined	Undefined	Undefined	Undefined

\*1 Note: Alarm mask bit, using to select Alarm 1 alarm rate.

\*2 Note: Alarm mask bit, using to select Alarm 2 alarm rate.

## Alarm Function

### Related Register

Addr. (hex)	Function	Register definition							
		Bit 7	Bit 6	Bit 5	Bit 4	Bit 3	Bit 2	Bit 1	Bit 0
00	Seconds	0	S40	S20	S10	S8	S4	S2	S1
01	Minutes	0	M40	M20	M10	M8	M4	M2	M1
02	Hours	0	12, /24	H20 or A, /P	H10	H8	H4	H2	H1
03	Days of the week	0	0	0	0	0	W4	W2	W1
04	Dates	0	0	D20	D10	D8	D4	D2	D1
07	Alarm 1: Seconds	A1M1	S40	S20	S10	S8	S4	S2	S1
08	Alarm 1: Minutes	A1M2	M40	M20	M10	M8	M4	M2	M1
09	Alarm 1: Hours	A1M3	12, /24	H20 or A, /P	H10	H8	H4	H2	H1
0A	Alarm 1: Day, Date	A1M4	Day, /Date	0, D20	0, D10	0, D8	W4, D4	W2, D2	W1, D1
0B	Alarm 2: Minutes	A2M2	M40	M20	M10	M8	M4	M2	M1
0C	Alarm 2: Hours	A2M3	12, /24	H20 or A, /P	H10	H8	H4	H2	H1
0D	Alarm 2: Day, Date	A2M4	Day, /Date	0, D20	0, D10	0, D8	W4, D4	W2, D2	W1, D1
0E	Control	/ETIME	0	0	RS2	RS1	INTCN	A2IE	A1IE
0F	Status	OSF	0	0	0	0	0	A2F	A1F

**Note:** Alarm function does not support different hour system adopted in time and alarm register.

The PT7C4337A contains two time-of-day/date alarms. The alarms can be programmed (by the INTCN bit of the control register) to operate in two different modes - each alarm can drive its own separate interrupt output or both alarms can drive a common interrupt output. Bit 7 of each of the time-of-day/date alarm registers are mask bits.

When all of the mask bits for each alarm are logic 0, an alarm only occurs when the values in the timekeeping registers 00h ~ 04h match the values stored in the time-of-day/date alarm registers. The alarms can also be programmed to repeat every second, minute, hour, day, or date. Table 2 and Table 3 show the possible settings.

The Day, /Date bits (bit 6 of the alarm day/date registers) control whether the alarm value stored in bits 0 ~ 5 of that register reflects the day of the week or the date of the month. If the bit is written to logic 0, the alarm is the result of a match with date of the month. If the bit is written to logic 1, the alarm is the result of a match with day of the week.

When the PT7C4337A register values match alarm register settings, the corresponding alarm flag (A1F or A2F) bit is set to logic 1. If the corresponding alarm interrupt enable (A1IE or A2IE) is also set to logic 1, the alarm condition activates one of the interrupt output (INTA or SQW/INTB) signals. The match is tested on the once-per-second update of the time and date registers.

**Table 3.** Alarm 1 Mask Bits

Day, /Date	Alarm 1 register mask bits				Alarm Rate
	A1M4	A1M3	A1M2	A1M1	
×	1	1	1	1	Alarm once per second
×	1	1	1	0	Alarm when seconds match
×	1	1	0	0	Alarm when minutes and seconds match
×	1	0	0	0	Alarm when hours, minutes, and seconds match
0	0	0	0	0	Alarm when date, hours, minutes, and seconds match
1	0	0	0	0	Alarm when day, hours, minutes, and seconds match
Others					Ignored.

**Table 4.** Alarm 2 Mask Bits

Day, /Date	Alarm 2 register mask bits			Alarm Rate
	A2M4	A2M3	A2M2	
×	1	1	1	Alarm once per minute (00 seconds of every minute)
×	1	1	0	Alarm when minutes match
×	1	0	0	Alarm when hours, minutes
0	0	0	0	Alarm when date, hours, and minutes match
1	0	0	0	Alarm when day, hours, and minutes match
Others				Ignored.

## I<sup>2</sup>C Bus Interface

### Overview of I<sup>2</sup>C-BUS

The I<sup>2</sup>C bus supports bi-directional communications via two signal lines: the SDA (data) line and SCL (clock) line. A combination of these two signals is used to transmit and receive communication start/stop signals, data signals, acknowledge signals, and so on. Both the SCL and SDA signals are held at high level whenever communications are not being performed. The starting and stopping of communications is controlled at the rising edge or falling edge of SDA while SCL is at high level. During data transfers, data changes that occur on the SDA line are performed while the SCL line is at low level, and on the receiving side the data is captured while the SCL line is at high level. In either case, the data is transferred via the SCL line at a rate of one bit per clock pulse. The I<sup>2</sup>C bus device does not include a chip select pin such as is found in ordinary logic devices. Instead of using a chip select pin, slave addresses are allocated to each device and the receiving device responds to communications only when its slave address matches the slave address in the received data.

### System Configuration

All ports connected to the I<sup>2</sup>C bus must be either open drain or open collector ports in order to enable AND connections to multiple devices.

SCL and SDA are both connected to the VDD line via a pull-up resistance. Consequently, SCL and SDA are both held at high level when the bus is released (when communication is not being performed).

**Figure 1. System Configuration**

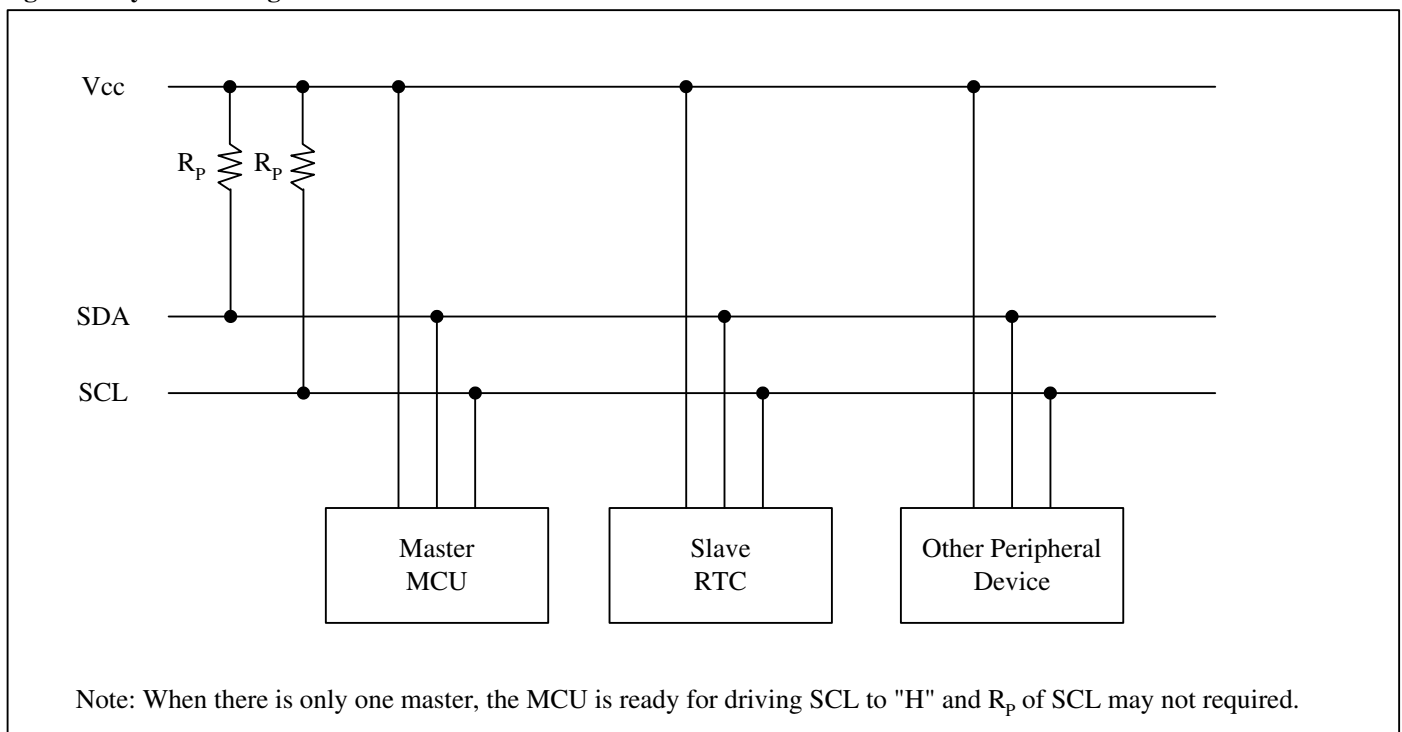

## Starting and Stopping I<sup>2</sup>C Bus Communications

Figure 2. Starting and Stopping on I<sup>2</sup>C Bus

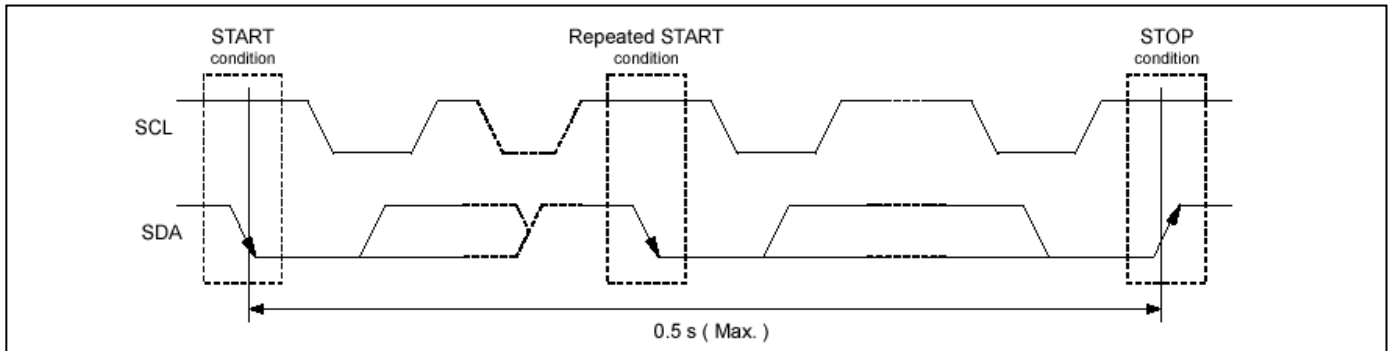

### 1) START Condition, Repeated START Condition, and STOP Condition

- a) START condition  
SDA level changes from high to low while SCL is at high level
- b) STOP condition  
SDA level changes from low to high while SCL is at high level
- c) Repeated START condition (RESTART condition)

In some cases, the START condition occurs between a previous START condition and the next STOP condition, in which case the second START condition is distinguished as a RESTART condition. Since the required status is the same as for the START condition, the SDA level changes from high to low while SCL is at high level.

### 2) Data Transfers and Acknowledge Responses during I<sup>2</sup>C-BUS Communication

#### a) Data Transfers

Data transfers are performed in 8-bit (1 byte) units once the START condition has occurred. There is no limit on the amount (bytes) of data that are transferred between the START condition and STOP condition.

The address auto increment function operates during both write and read operations.

Updating of data on the transmitter (transmitting side)'s SDA line is performed while the SCL line is at low level. The receiver (receiving side) captures data while the SCL line is at high level.

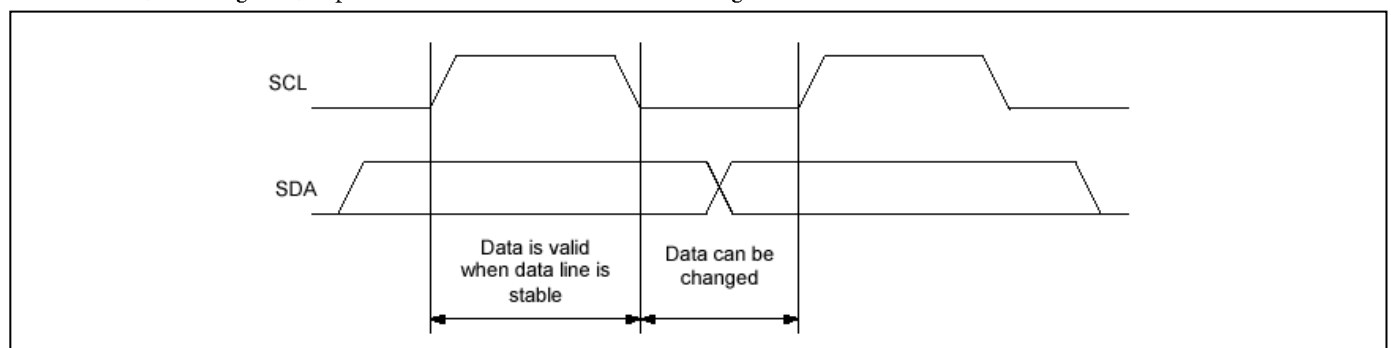

\*Note with caution that if the SDA data is changed while the SCL line is at high level, it will be treated as a START, RESTART, or STOP condition.

#### b) Data Acknowledge Response (ACK signal)

When transferring data, the receiver generates a confirmation response (ACK signal, low active) each time an 8-bit data segment is received. If there is no ACK signal from the receiver, it indicates that normal communication has not been established. (This does not include instances where the master device intentionally does not generate an ACK signal.)



Immediately after the falling edge of the clock pulse corresponding to the 8th bit of data on the SCL line, the transmitter releases the SDA line and the receiver sets the SDA line to low (= acknowledge) level.

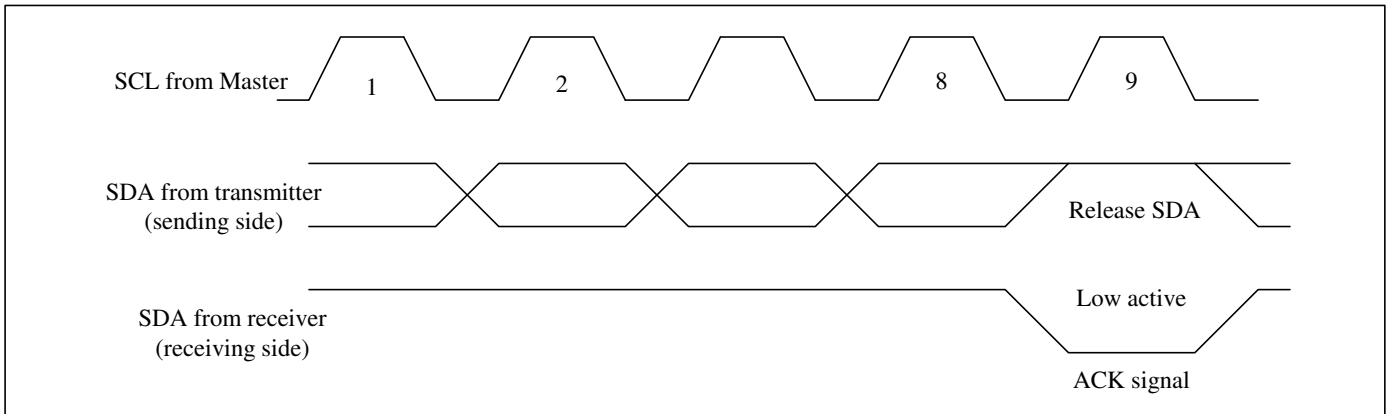

After transmitting the ACK signal, if the Master remains the receiver for transfer of the next byte, the SDA is released at the falling edge of the clock corresponding to the 9th bit of data on the SCL line. Data transfer resumes when the Master becomes the transmitter.

When the Master is the receiver, if the Master does not send an ACK signal in response to the last byte sent from the slave, that indicates to the transmitter that data transfer has ended. At that point, the transmitter continues to release the SDA and awaits a STOP condition from the Master.

**Slave Address**

The I<sup>2</sup>C bus device does not include a chip select pin such as is found in ordinary logic devices. Instead of using a chip select pin, slave addresses are allocated to each device.

All communications begin with transmitting the [START condition] + [slave address (+ R/W specification)]. The receiving device responds to this communication only when the specified slave address it has received matches its own slave address.

Slave addresses have a fixed length of 7 bits. See table for the details.

An R/W bit is added to each 7-bit slave address during 8-bit transfers.

Operation	Transfer data	Slave address							R / W bit
		bit 7	bit 6	bit 5	bit 4	bit 3	bit 2	bit 1	bit 0
Read	D1 h	1	1	0	1	0	0	0	1 (= Read)
Write	D0 h	1	1	0	1	0	0	0	0 (= Write)

**I<sup>2</sup>C Bus's Basic Transfer Format**

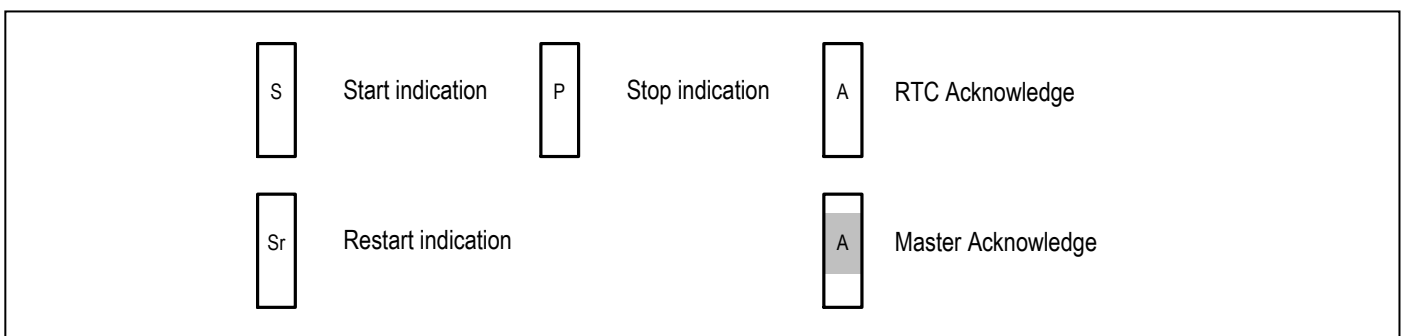

**1) Write via I<sup>2</sup>C Bus**

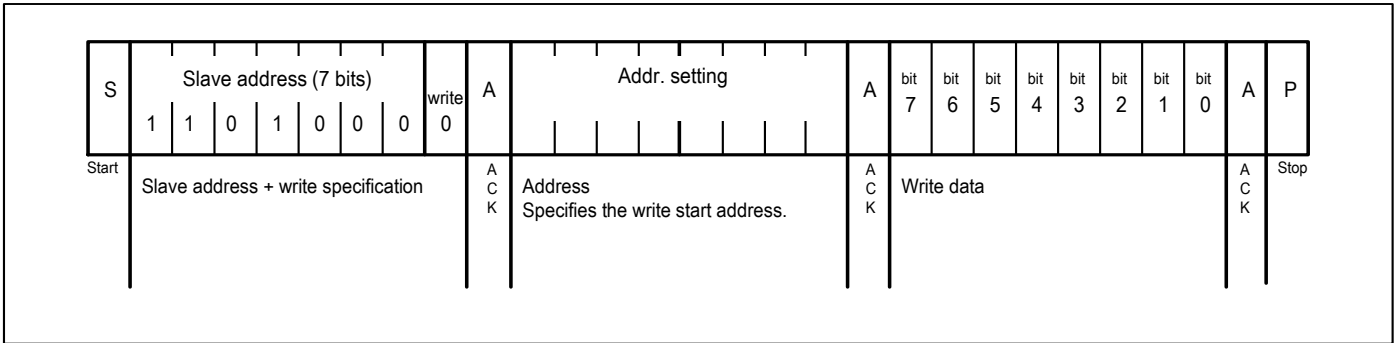

**2) Read via I<sup>2</sup>C bus**

**a) Standard Read**

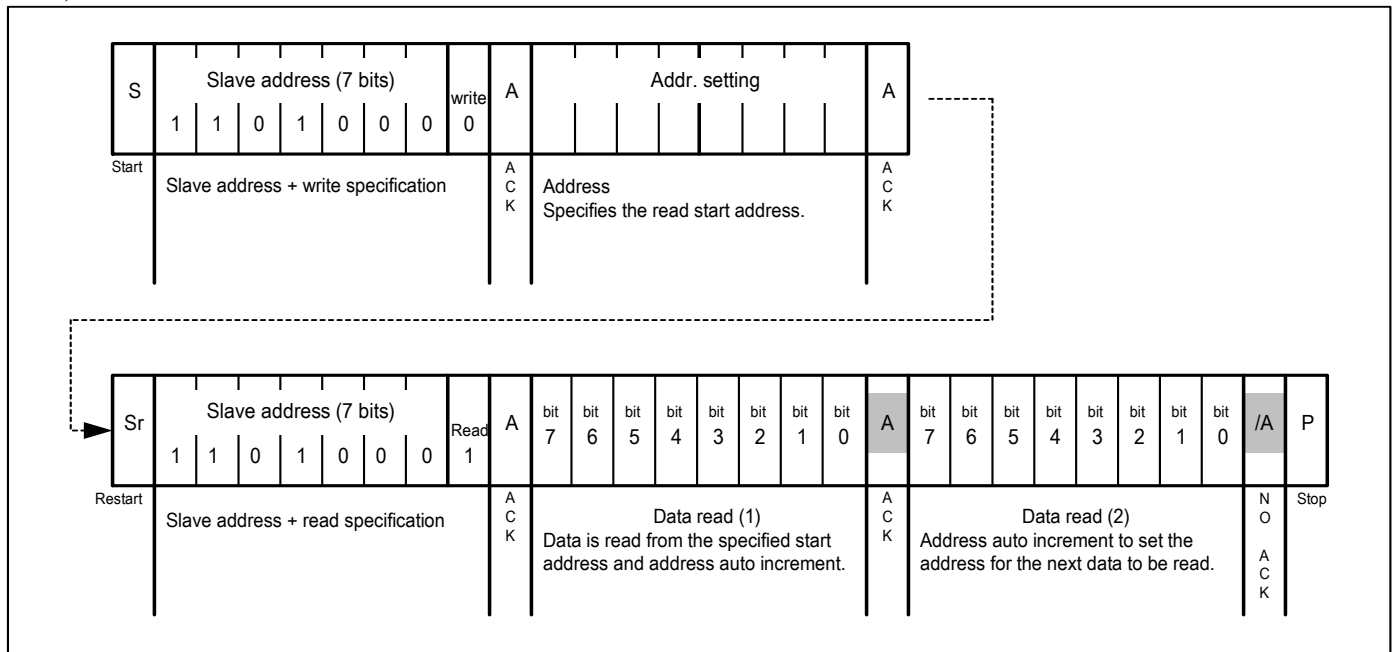

**b) Simplified Read**

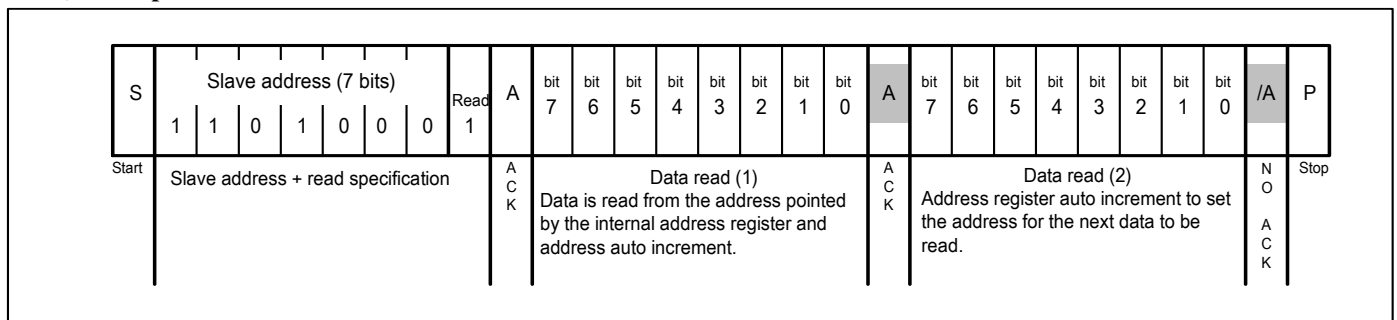

- Note:**
- The above steps are an example of transfers of one or two bytes only. There is no limit to the number of bytes transferred during actual communications.
  - 49H, 4AH are used as test mode address. Customer should not use the addresses.

## Part Marking

### PT7C4337A

#### W Package

PT7C  
4337AWE  
SYWXX  
●

S: Die Rev

Y: Date Code (Year)

W: Date Code (Workweek)

2nd X: Assembly Site Code

3rd X: Fab Site Code

#### U and L Package

Top mark not available at this time. To obtain advance information regarding the top mark, please contact your local sales representative.

### PT7C4337AC

#### S Package

**PT** 7C4337ACSE  
SYYWWGG  
●

S: Die Rev

YYWW: Date Code (Year & Workweek)

1st G: Assembly Site Code

2nd G: Wafer Fab Site Code

**Packaging Mechanical**

**8-SOIC (W)**

SYMBOLS	MIN.	NOM.	MAX.
A	—	—	1.75
A1	0.10	—	0.25
A2	1.25	—	—
b	0.31	—	0.51
c	0.10	—	0.25
D	4.80	4.90	5.00
E	5.80	6.00	6.20
E1	3.80	3.90	4.00
e	1.27 BSC		
L	0.40	—	1.27
h	0.25	—	0.50
$\theta^\circ$	0	—	8

UNIT : mm

**NOTE :**  
 1. ALL DIMENSIONS ARE IN mm. ANGLES IN DEGREES  
 2. DIMENSIONS EXCLUDE BURRS, MOLD FLASH OR PROTRUSIONS  
 3. REFER JEDEC MS-012

**PERICOM**  
Enabling Serial Connectivity

DATE: 02/21/14

DESCRIPTION: 8-Pin, 150mil-Wide, SOIC

PACKAGE CODE: W (W8)

DOCUMENT CONTROL #: PD-1001 REVISION: G

15-0103

**8-MSOP (U)**

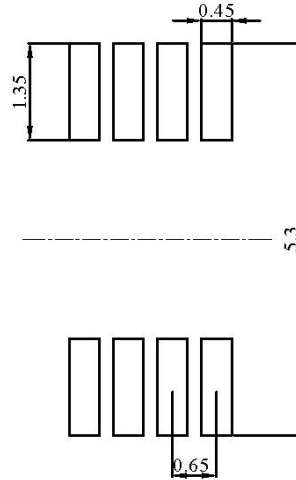
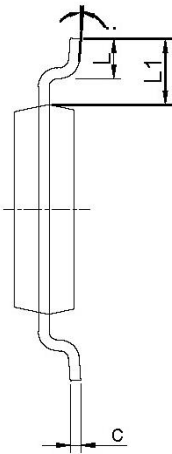
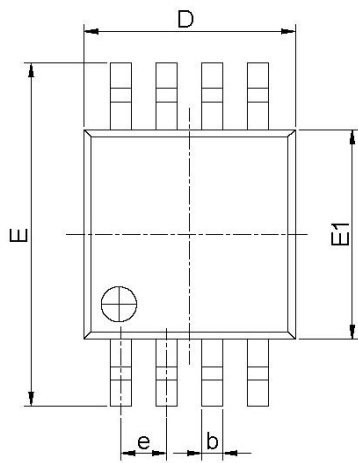

PKG DIMENSIONS(MM)		
SYMBOL	Min.	Max.
A	—	1.10
A1	0.00	0.15
A2	0.75	0.95
b	0.22	0.38
c	0.08	0.23
D	2.80	3.20
E	4.65	5.15
E1	2.80	3.20
e	0.65 BSC	
L	0.40	0.80
L1	0.95 REF	
θ	0°	8°

RECOMMENDED LAND PATTERN(unit:mm)

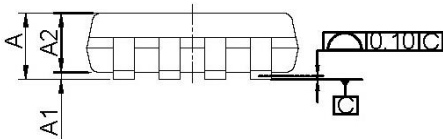

**NOTE:**

1. ALL DIMENSIONS ARE IN MILLIMETERS. ANGLES IN DEGREES.
2. REFER JEDEC MO-187F/AA
3. PACKAGE OUTLINE DIMENSIONS DO NOT INCLUDE MOLD FLASH AND METAL BURR.
4. LAND PATTERN REFERENCE DIODES MSOP-8 PACKAGE INFORMATION.

8-TSSOP (L)

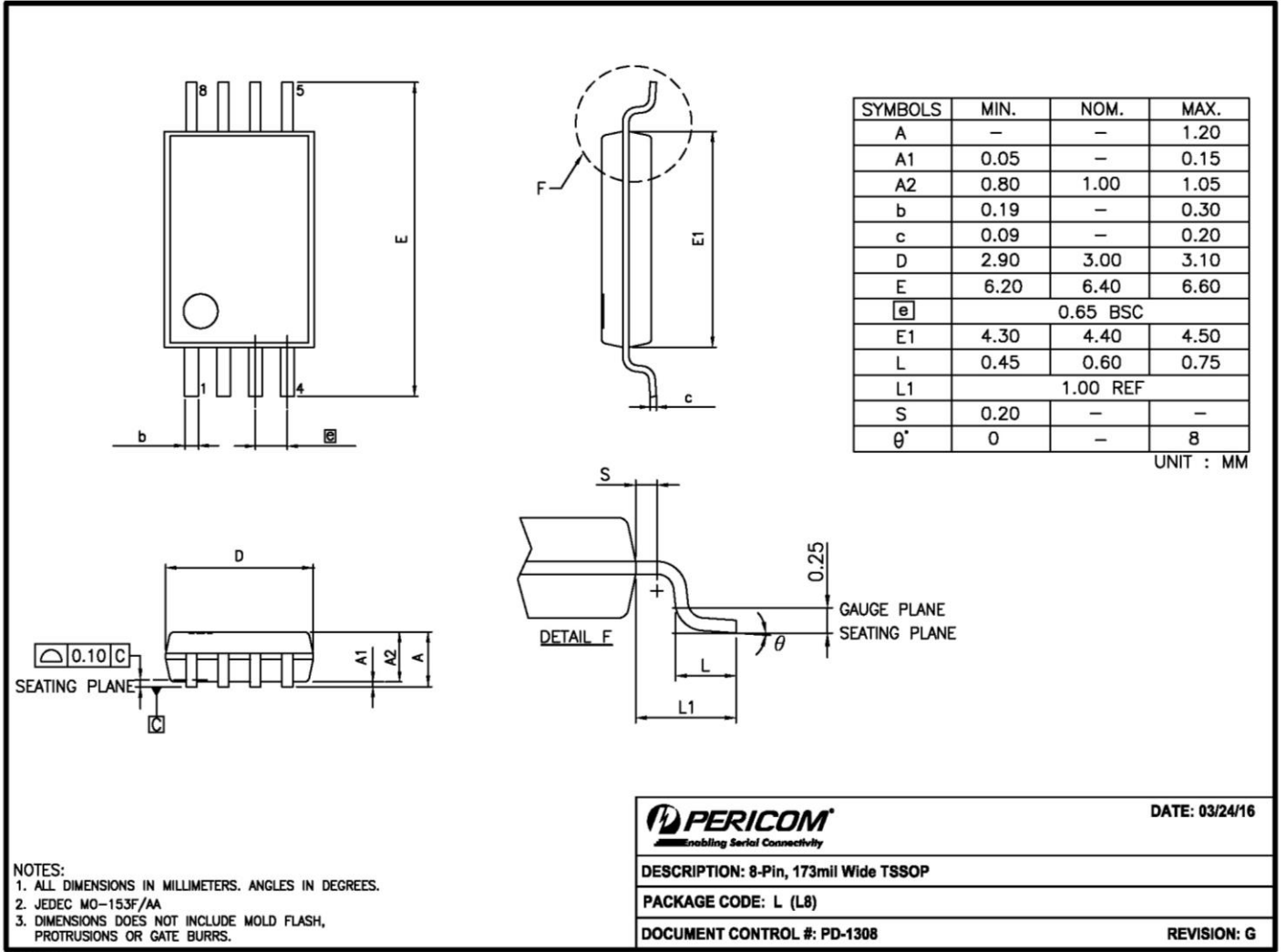

16-0062

**16-SOIC (S)**

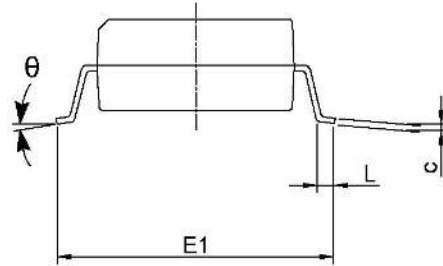
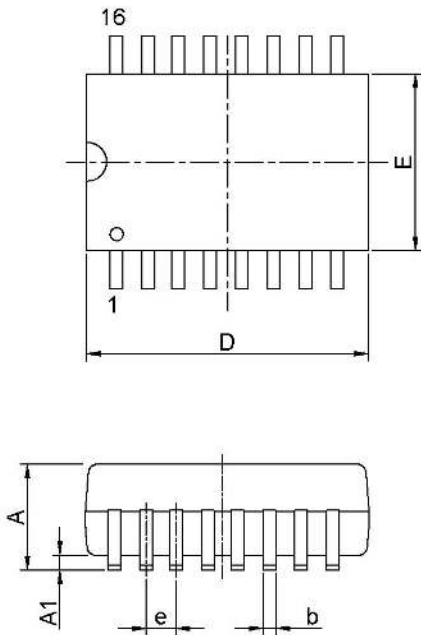

PKG. DIMENSIONS(MM)		
SYMBOL	Min	Max
A	2.35	2.64
A1	0.10	0.30
b	0.33	0.51
c	0.23	0.32
D	10.10	10.50
E	7.40	7.60
E1	10.00	10.65
e	1.27 BSC	
L	0.41	1.27
θ	0°	8°

Note:  
1. Ref: JEDEC MS-013 AA



DATE: 08/29/14

DESCRIPTION: 16-Pin, SOIC (300 MIL WIDE)

PACKAGE CODE: S (S16)

DOCUMENT CONTROL #: PD-1005

REVISION: E

14-0238

For latest package info.

please check: <http://www.diodes.com/design/support/packaging/pericom-packaging/packaging-mechanicals-and-thermal-characteristics/>

**Ordering Information**

Part Number	Package Code	Package Description
PT7C4337AWEX	W	8-Pin, 150mil-Wide (SOIC)
PT7C4337AUEx	U	8-Pin, Mini Small Outline Package (MSOP)
PT7C4337ALEX	L	8-Pin, 173mil Wide (TSSOP)
PT7C4337ACSEX	S	16-Pin, 300mil Wide (SOIC)

**Notes:**

- No purposely added lead. Fully EU Directive 2002/95/EC (RoHS), 2011/65/EU (RoHS 2) & 2015/863/EU (RoHS 3) compliant.
- See <https://www.diodes.com/quality/lead-free/> for more information about Diodes Incorporated's definitions of Halogen- and Antimony-free, "Green" and Lead-free.
- Halogen- and Antimony-free "Green" products are defined as those which contain <900ppm bromine, <900ppm chlorine (<1500ppm total Br + Cl) and <1000ppm antimony compounds.
- E = Pb-free and Green
- X suffix = Tape/Reel

**IMPORTANT NOTICE**

DIODES INCORPORATED MAKES NO WARRANTY OF ANY KIND, EXPRESS OR IMPLIED, WITH REGARDS TO THIS DOCUMENT, INCLUDING, BUT NOT LIMITED TO, THE IMPLIED WARRANTIES OF MERCHANTABILITY AND FITNESS FOR A PARTICULAR PURPOSE (AND THEIR EQUIVALENTS UNDER THE LAWS OF ANY JURISDICTION).

Diodes Incorporated and its subsidiaries reserve the right to make modifications, enhancements, improvements, corrections or other changes without further notice to this document and any product described herein. Diodes Incorporated does not assume any liability arising out of the application or use of this document or any product described herein; neither does Diodes Incorporated convey any license under its patent or trademark rights, nor the rights of others. Any Customer or user of this document or products described herein in such applications shall assume all risks of such use and will agree to hold Diodes Incorporated and all the companies whose products are represented on Diodes Incorporated website, harmless against all damages.

Diodes Incorporated does not warrant or accept any liability whatsoever in respect of any products purchased through unauthorized sales channel.

Should Customers purchase or use Diodes Incorporated products for any unintended or unauthorized application, Customers shall indemnify and hold Diodes Incorporated and its representatives harmless against all claims, damages, expenses, and attorney fees arising out of, directly or indirectly, any claim of personal injury or death associated with such unintended or unauthorized application.

Products described herein may be covered by one or more United States, international or foreign patents pending. Product names and markings noted herein may also be covered by one or more United States, international or foreign trademarks.

This document is written in English but may be translated into multiple languages for reference. Only the English version of this document is the final and determinative format released by Diodes Incorporated.

**LIFE SUPPORT**

Diodes Incorporated products are specifically not authorized for use as critical components in life support devices or systems without the express written approval of the Chief Executive Officer of Diodes Incorporated. As used herein:

A. Life support devices or systems are devices or systems which:

1. are intended to implant into the body, or
2. support or sustain life and whose failure to perform when properly used in accordance with instructions for use provided in the labeling can be reasonably expected to result in significant injury to the user.

B. A critical component is any component in a life support device or system whose failure to perform can be reasonably expected to cause the failure of the life support device or to affect its safety or effectiveness.

Customers represent that they have all necessary expertise in the safety and regulatory ramifications of their life support devices or systems, and acknowledge and agree that they are solely responsible for all legal, regulatory and safety-related requirements concerning their products and any use of Diodes Incorporated products in such safety-critical, life support devices or systems, notwithstanding any devices- or systems-related information or support that may be provided by Diodes Incorporated. Further, Customers must fully indemnify Diodes Incorporated and its representatives against any damages arising out of the use of Diodes Incorporated products in such safety-critical, life support devices or systems.

Copyright © 2020, Diodes Incorporated  
[www.diodes.com](http://www.diodes.com)