

WIRE READY SPEC. (OPTION -47)  
(FOR OPTIONAL SCREW -50  
AND STANDARD SCREW.)

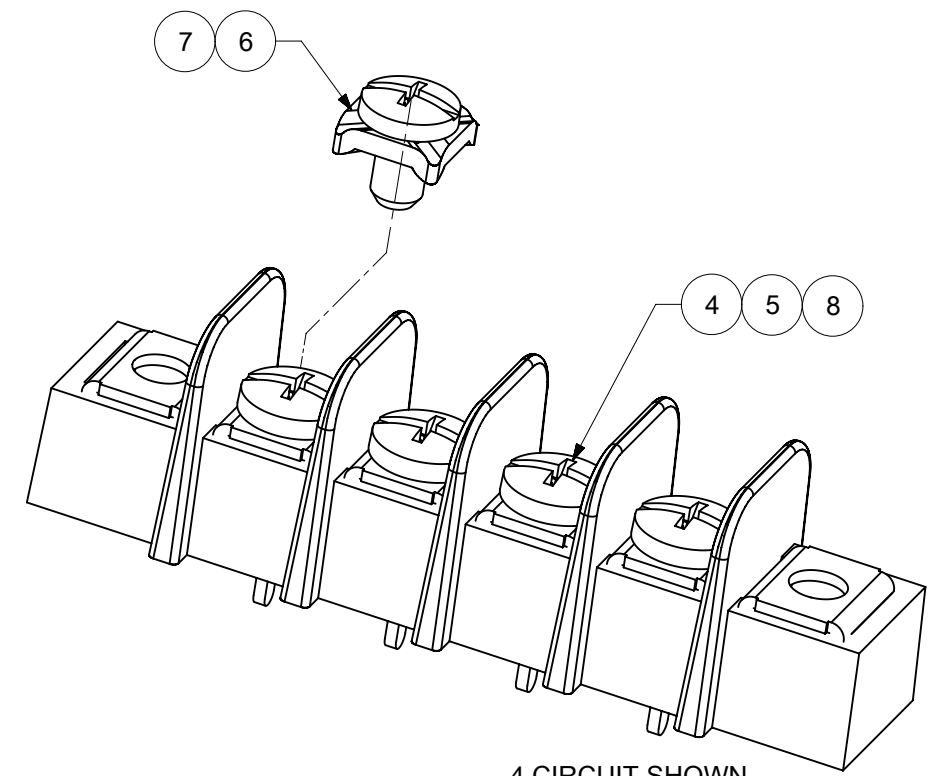

4 CIRCUIT SHOWN

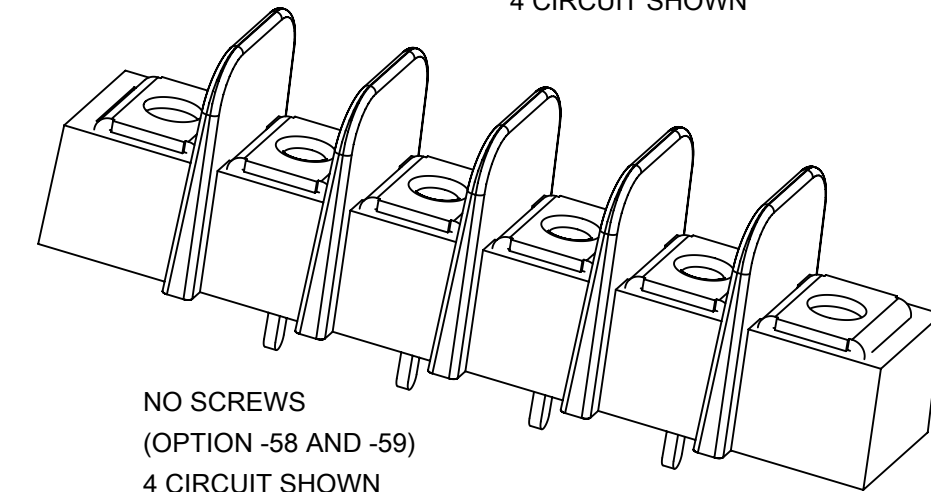
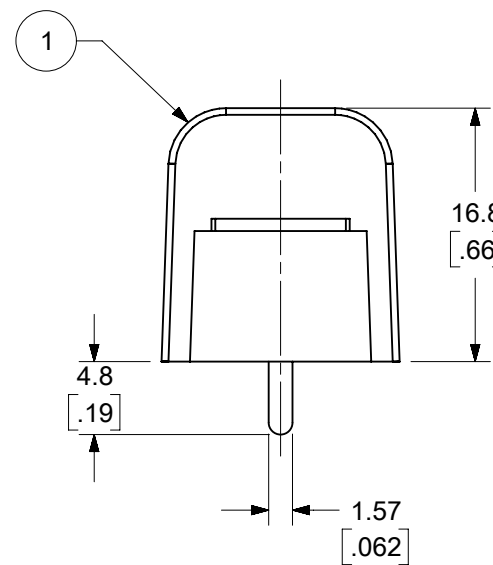
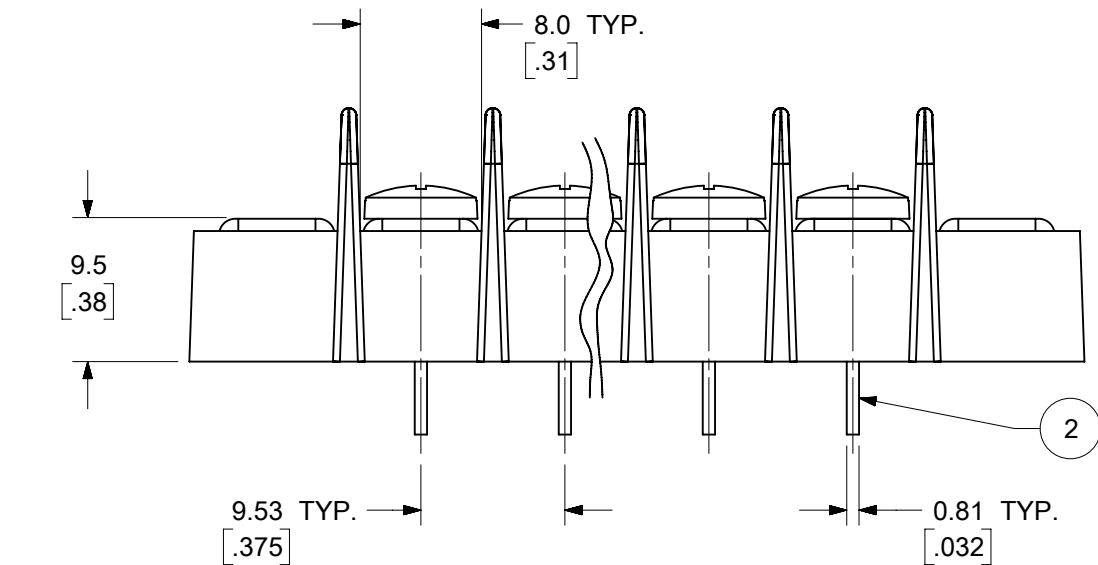

NO SCREWS  
(OPTION -58 AND -59)  
4 CIRCUIT SHOWN

NOTES:

1. MATERIAL: SEE TABLE
2. FINISHES: SEE TABLE
3. INCH DIMENSIONS ARE IN BRACKETS [XXX].
4. REFER TO SD-38120-001 FOR IMPRINTING OPTIONS 10A AND 11A.
5. REFER TO SD-38120-007 FOR IMPRINTING OPTION 12A.
6. "XX" REFERS TO THE QUANTITY OF CIRCUITS.
7. ALL COMPONENTS ARE ROHS COMPLIANT.

10	XX	#6-32 WRDY W/WASH SCR (OPT -47,-50)	STEEL	ZN, CLEAR CHROMATE
9	XX	#6-32 PH/SLOT WRDY SCR (OPT -47)	STEEL	ZN, CLEAR CHROMATE
8	XX	#6-32 BHD, PHIL-SLOT SST SCR (OPT -56)	STAINLESS STEEL	PASSIVATE
7	XX	#6-32 PH/SL W/WASH SCR (OPT -49,-50)	BRASS	NICKEL
6	XX	#6-32 PH/SL W/WASH SCR (OPT -50)	STEEL	ZN, CLEAR CHROMATE
5	XX	#6-32 PH/SLOTTED SCREW (OPT -49)	BRASS	NICKEL
4	XX	#6-32 PH/SLOTTED SCREW (STD)	STEEL	ZN, CLEAR CHROMATE
3	2	MOUNTING PLATE	BRASS	NICKEL
2	XX	TERMINAL, PC	BRASS	BRT. TIN/CU
1	1	INSULATOR, SINGLE ROW	PBT	BLACK
ITEM	QTY.	DESCRIPTION	MATERIAL	FINISH

TOLERANCES			
MM	TOL	INCH	TOL
0-6	±0.25	0-.24	±.010
>6-30	±0.40	.24-1.18	±.016
>30-120	±0.50	1.18-4.76	±.020
>120	±0.80	>4.76	±.031

SYMBOLS		THIS DRAWING CONTAINS INFORMATION THAT IS PROPRIETARY TO MOLEX ELECTRONIC TECHNOLOGIES, LLC AND SHOULD NOT BE USED WITHOUT WRITTEN PERMISSION	
▽ = 0	DIMENSION UNITS	SCALE	CURRENT REV DESC: ADDED PNS 387290485 & 387291667
▽ = 0	MM/INCH	2:1	
▽ = 0	GENERAL TOLERANCES (UNLESS SPECIFIED)		
▽ = 0	4 PLACES ±	MM	INCH
▽ = 0	3 PLACES ±	SEE CHART	SEE CHART
▽ = 0	2 PLACES ±	SEE CHART	SEE CHART
▽ = 0	1 PLACE ±	SEE CHART	SEE CHART
▽ = 0	0 PLACES ±	SEE CHART	SEE CHART
▽ = 0	ANGULAR TOL	±	---
▽ = 0	DRAFT WHERE APPLICABLE MUST REMAIN WITHIN DIMENSIONS		THIRD ANGLE PROJECTION
▽ = 0		DRAWING	SERIES
		B-SIZE	38720
DOCUMENT NUMBER		CUSTOMER	SHEET NUMBER
SD-38720-001		GENERAL MARKET	1 OF 2
EC NO: 627921		DRWN: ABENJAMINLW	2019/11/18
DRWN: DACHAMMER		2019/12/04	
APPR: JFMURPHY		2019/12/05	
INITIAL REVISION:		DRWN: CLYORK	2006/10/19
		APPR: JMACNEIL	2006/10/20
MATERIAL NUMBER		CUSTOMER	SHEET NUMBER
SEE SHEET-2		GENERAL MARKET	1 OF 2

NUMBER OF CIRCUITS "XX"	MATERIAL NO. (OPT 12A)	MATERIAL NO. (OPT 11A)	MATERIAL NO. (OPT 10A)	MATERIAL NO. (OPT -59)	MATERIAL NO. (OPT -58)	MATERIAL NO. (OPT -56)	MATERIAL NO. (OPT -50)	MATERIAL NO. (OPT -49,-50)	MATERIAL NO. (OPT -49)	MATERIAL NO. (OPT -49,-59)	MATERIAL NO. (OPT -47,-50)	MATERIAL NO. (STD)	NUMBER OF CIRCUITS "XX"
01						387290659						387206201	01
02			387291039		387290750	387290791	387207402	387291381	387206802			387206202	02
03	387290872	387290025	387290014			387290117	387207403		387206803		387208603	387206203	03
04			387290940	387290945		387290839	387207404	387291159	387206804			387206204	04
05	387290256		387290346			387291253	387207405	387291382	387206805			387206205	05
06				387290400	387290386	387290980	387207406	387291383	387206806			387206206	06
07			387290423	387290407		387290435	387207407		387206807			387206207	07
08	387290497					387290508	387207408		387206808	387290485		387206208	08
09			387290548			387290560	387207409		387206809			387206209	09
10			387291011	387290598	387290598	387291663	387207410		387206810			387206210	10
11						387291252	387207411					387206211	11
12			387290720			387290735	387207412		387206812	387291667		387206212	12
13						387290809	387207413					387206213	13
14						387290004	387207414		387206814			387206214	14
15												387206215	15
16												387206216	16
17												387206217	17
18												387206218	18
19												387206219	19
20												387206220	20
21												387206221	21
22												387206222	22
23												387206223	23
24												387206224	24
25												387206225	25
26												387206226	26

NUMBER OF CIRCUITS "XX"	DIM. "A"		DIM. "B"		DIM. "C"		DIM. "D"	
01	30.7	[1.21]	--	--	19.1	[.75]	11.6	[.46]
02	40.1	[1.58]	9.53	[.375]	28.6	[1.13]	21.1	[.83]
03	49.7	[1.96]	19.05	[.750]	38.1	[1.50]	30.6	[1.21]
04	59.2	[2.33]	28.58	[1.125]	47.6	[1.88]	40.1	[1.58]
05	68.7	[2.71]	38.10	[1.500]	57.2	[2.25]	49.7	[1.96]
06	78.2	[3.08]	47.63	[1.875]	66.7	[2.63]	59.2	[2.33]
07	87.8	[3.46]	57.15	[2.250]	76.2	[3.00]	68.7	[2.71]
08	97.3	[3.83]	66.68	[2.625]	85.7	[3.38]	78.2	[3.08]
09	106.8	[4.21]	76.20	[3.000]	95.3	[3.75]	87.8	[3.46]
10	116.3	[4.58]	85.73	[3.375]	104.8	[4.13]	97.3	[3.83]
11	125.9	[4.96]	95.25	[3.750]	114.3	[4.50]	106.8	[4.21]
12	135.4	[5.33]	104.78	[4.125]	123.8	[4.88]	116.3	[4.58]
13	144.9	[5.71]	114.30	[4.500]	133.4	[5.25]	125.9	[4.96]
14	154.4	[6.08]	123.83	[4.875]	142.9	[5.63]	135.4	[5.33]
15	164.0	[6.46]	133.35	[5.250]	152.4	[6.00]	144.9	[5.71]
16	173.5	[6.83]	142.88	[5.625]	161.9	[6.38]	154.4	[6.08]
17	183.0	[7.21]	152.40	[6.000]	171.5	[6.75]	164.0	[6.46]
18	192.5	[7.58]	161.93	[6.375]	181.0	[7.13]	173.5	[6.83]
19	202.1	[7.96]	171.45	[6.750]	190.5	[7.50]	183.0	[7.21]
20	211.6	[8.33]	180.98	[7.125]	200.0	[7.88]	192.5	[7.58]
21	221.1	[8.71]	190.50	[7.500]	209.6	[8.25]	202.1	[7.96]
22	230.6	[9.08]	200.03	[7.875]	219.1	[8.63]	211.6	[8.33]
23	240.2	[9.46]	209.55	[8.250]	228.6	[9.00]	221.1	[8.71]
24	249.7	[9.83]	219.08	[8.625]	238.1	[9.38]	230.6	[9.08]
25	259.2	[10.21]	228.60	[9.000]	247.7	[9.75]	240.2	[9.46]
26	268.7	[10.58]	238.13	[9.375]	257.2	[10.13]	249.7	[9.83]

TOLERANCES			
MM	TOL	INCH	TOL
0-6	±0.25	0-.24	±.010
>6-30	±0.40	.24-1.18	±.016
>30-120	±0.50	1.18-4.76	±.020
>120	±0.80	>4.76	±.031

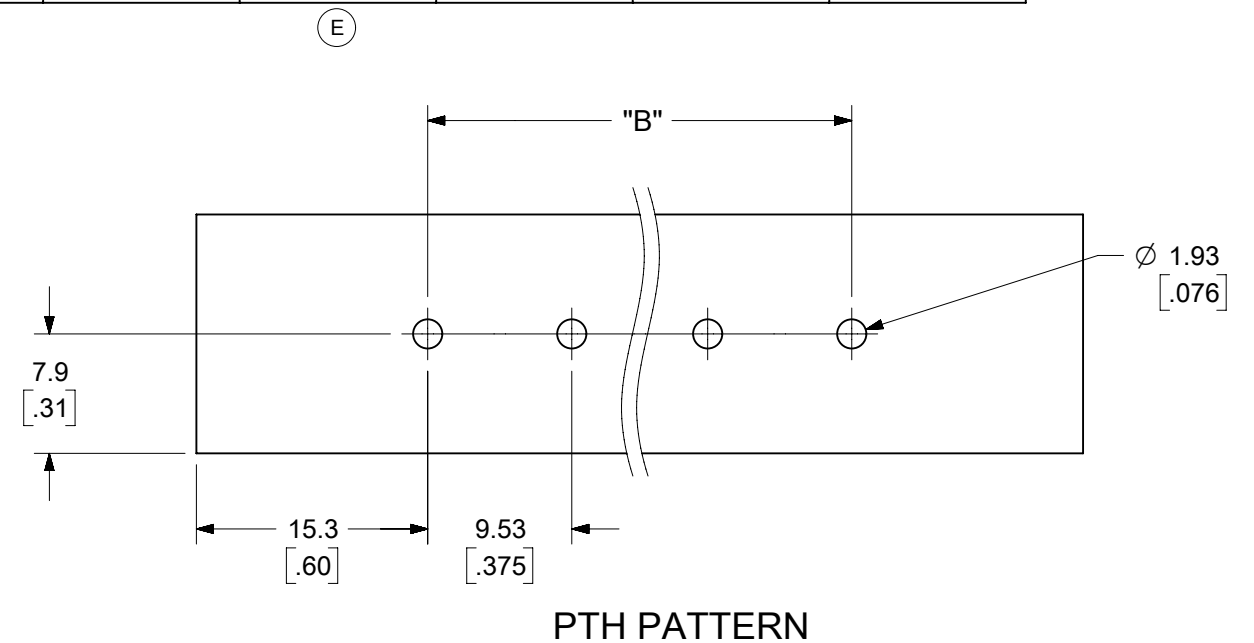

THIS DRAWING CONTAINS INFORMATION THAT IS PROPRIETARY TO MOLEX ELECTRONIC TECHNOLOGIES, LLC AND SHOULD NOT BE USED WITHOUT WRITTEN PERMISSION													
SYMBOLS		DIMENSION UNITS		SCALE		CURRENT REV DESC: ADDED PNS 387290485 & 387291667							
▽ = 0		MM/INCH		2:1		<b>molex</b> 9.53MM [.375"] SR BTS, PC ASSY PRODUCT CUSTOMER DRAWING DOCUMENT NUMBER: SD-38720-001   DOC TYPE: PSD   DOC PART: 001   REVISION: E MATERIAL NUMBER: SEE CHART   CUSTOMER: GENERAL MARKET   SHEET NUMBER: 2 OF 2							
▽ = 0		GENERAL TOLERANCES (UNLESS SPECIFIED)											
▽ = 0		4 PLACES ± --- ± ---		MM								INCH	
▽ = 0		3 PLACES ± --- ± ---		SEE CHART								SEE CHART	
▽ = 0		2 PLACES ± --- ± ---		SEE CHART								SEE CHART	
▽ = 0		1 PLACE ± --- ± ---		SEE CHART		SEE CHART							
▽ = 0		0 PLACES ± --- ± ---		SEE CHART		SEE CHART							
⊠ = 0		ANGULAR TOL ± ---				THIRD ANGLE PROJECTION		DRAWING		SERIES			
■ = 0		DRAFT WHERE APPLICABLE MUST REMAIN WITHIN DIMENSIONS				B-SIZE		38720					

	10	9	8	7	6	5	4	3	2	1	
	NUMBER OF CIRCUITS *XX*	MATERIAL NO. (OPT 12A)	MATERIAL NO. (OPT 11A)	MATERIAL NO. (OPT 10A)	MATERIAL NO. (OPT -59)	MATERIAL NO. (OPT -58)	MATERIAL NO. (OPT -56)	MATERIAL NO. (OPT -50)	MATERIAL NO. (OPT -49,-50)	MATERIAL NO. (OPT -49)	MATERIAL NO. (OPT -47,-50) (STD)
	01						38729-0659				38720-6201
	02			38729-1039		38729-0750	38729-0791	38720-7402	38729-1381	38720-6802	38720-6202
	03	38729-0872	38729-0025	38729-0014			38729-0117	38720-7403		38720-6803	38720-8603
	04			38729-0940	38729-0945		38729-0839	38720-7404	38729-1159	38720-6804	38720-6204
	05	38729-0256		38729-0346			38729-1253	38720-7405	38729-1382	38720-6805	38720-6205
	06				38729-0400	38729-0386	38729-0980	38720-7406	38729-1383	38720-6806	38720-6206
	07			38729-0423	38729-0407	38729-0435	38729-0440	38720-7407		38720-6807	38720-6207
	08	38729-0497				38729-0508	38729-0532	38720-7408		38720-6808	38720-6208
	09			38729-0548		38729-0560		38720-7409		38720-6809	38720-6209
	10			38729-1011	38729-0598	38729-0598	38729-1663 (D)	38720-7410		38720-6810	38720-6210
	11						38729-1252	38720-7411			38720-6211
	12			38729-0720			38729-0735	38720-7412		38720-6812	38720-6212
	13					38729-0809		38720-7413			38720-6213
	14					38729-0004		38720-7414		38720-6814	38720-6214
	15										38720-6215
	16										38720-6216
	17										38720-6217
	18										38720-6218
	19										38720-6219
	20										38720-6220
	21										38720-6221
	22										38720-6222
	23										38720-6223
	24										38720-6224
	25										38720-6225
	26										38720-6226

NUMBER OF CIRCUITS *XX*	DIM. *A*		DIM. *B*		DIM. *C*		DIM. *D*	
01	30.7	[1.21]	-	-	19.1	[.75]	11.6	[.46]
02	40.1	[1.58]	9.53	[.375]	28.6	[1.13]	21.1	[.83]
03	49.7	[1.96]	19.05	[.750]	38.1	[1.50]	30.6	[1.21]
04	59.2	[2.33]	28.58	[1.125]	47.6	[1.88]	40.1	[1.58]
05	68.7	[2.71]	38.10	[1.500]	57.2	[2.25]	49.7	[1.96]
06	78.2	[3.08]	47.63	[1.875]	66.7	[2.63]	59.2	[2.33]
07	87.8	[3.46]	57.15	[2.250]	76.2	[3.00]	68.7	[2.71]
08	97.3	[3.83]	66.68	[2.625]	85.7	[3.38]	78.2	[3.08]
09	106.8	[4.21]	76.20	[3.000]	95.3	[3.75]	87.8	[3.46]
10	116.3	[4.58]	85.73	[3.375]	104.8	[4.13]	97.3	[3.83]
11	125.9	[4.96]	95.25	[3.750]	114.3	[4.50]	106.8	[4.21]
12	135.4	[5.33]	104.78	[4.125]	123.8	[4.88]	116.3	[4.58]
13	144.9	[5.71]	114.30	[4.500]	133.4	[5.25]	125.9	[4.96]
14	154.4	[6.08]	123.83	[4.875]	142.9	[5.63]	135.4	[5.33]
15	164.0	[6.46]	133.35	[5.250]	152.4	[6.00]	144.9	[5.71]
16	173.5	[6.83]	142.88	[5.625]	161.9	[6.38]	154.4	[6.08]
17	183.0	[7.21]	152.40	[6.000]	171.5	[6.75]	164.0	[6.46]
18	192.5	[7.58]	161.93	[6.375]	181.0	[7.13]	173.5	[7.21]
19	202.1	[7.96]	171.45	[6.750]	190.5	[7.50]	183.0	[7.58]
20	211.6	[8.33]	180.98	[7.125]	200.0	[7.88]	192.5	[7.96]
21	221.1	[8.71]	190.50	[7.500]	209.6	[8.25]	202.1	[8.33]
22	230.6	[9.08]	200.03	[7.875]	219.1	[8.63]	211.6	[8.71]
23	240.2	[9.46]	209.55	[8.250]	228.6	[9.00]	221.1	[9.08]
24	249.7	[9.83]	219.08	[8.625]	238.1	[9.38]	230.6	[9.46]
25	259.2	[10.21]	228.60	[9.000]	247.7	[9.75]	240.2	[9.83]
26	268.7	[10.58]	238.13	[9.375]	257.2	[10.13]	249.7	[10.58]

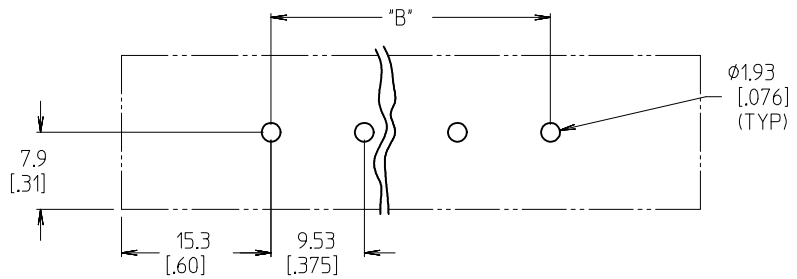

PTH PATTERN

<b>ADD 387291663 (10P)</b> EC NO: IPG2015-0703 D DRWHRSTONE 2014/10/27 CHKDB RUPERT 10/29/2014 APPR: BWOODMAN 2014/11/02 REV DESCRIPTION	QUALITY SYMBOLS	GENERAL TOLERANCES (UNLESS SPECIFIED)	DIMENSION STYLE	SCALE	DESIGN UNITS	THIRD ANGLE PROJECTION
	$\nabla=0$ $\nabla=0$	mm INCH 4 PLACES ± --- ± --- 3 PLACES ± --- ± .005 2 PLACES ± 0.13 ± .01 1 PLACE ± 0.3 ± --- ANGULAR ± 2 °	MM/IN	2:1	INCH	
		DRAFT WHERE APPLICABLE MUST REMAIN WITHIN DIMENSIONS	DRAWN BY DATE	TITLE		
			W. HOWARD 2003/10/16	9.53MM [.375"] SR BTS, PC ASSY		
		CHECKED BY DATE	MATERIAL NO.			
		R. KEMP 2003/10/16	38729-1663			
		APPROVED BY DATE	DOCUMENT NO.			
		P. WALTZ 2003/10/16	SD-38720-001			
			SHEET NO.			
			2 OF 2			
			THIS DRAWING CONTAINS INFORMATION THAT IS PROPRIETARY TO MOLEX INCORPORATED AND SHOULD NOT BE USED WITHOUT WRITTEN PERMISSION			