

Rev	AWO #	Description	Date	Appr
-		RELEASED	3/16/18	
A		UPDATED LAYOUT	4/24/18	HR/MY

APPROVED: _____
 DATE: _____ TITLE: _____

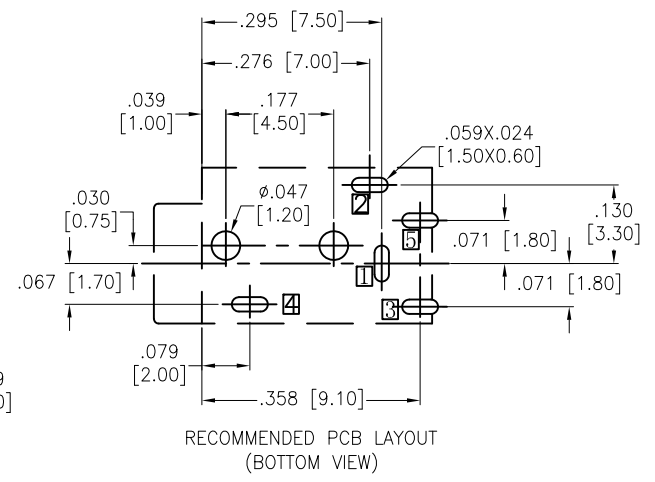

ADAM P/N	ASJ-190-A	ASJ-190-B	ASJ-190-C	ASJ-190-D
Schematic				

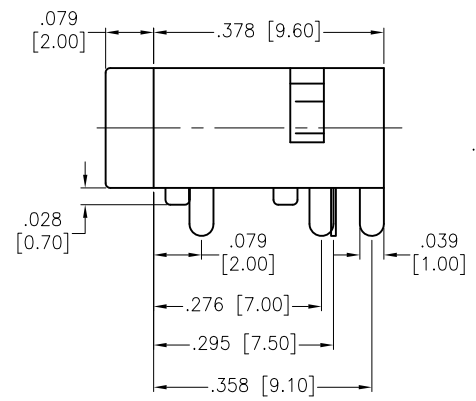
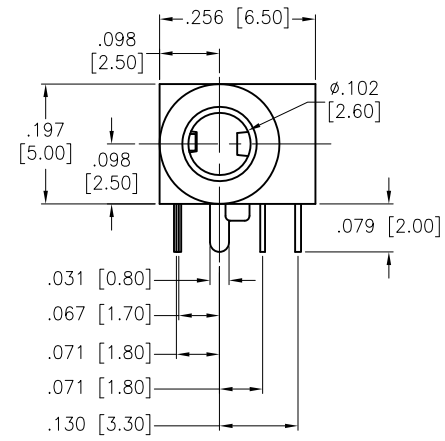
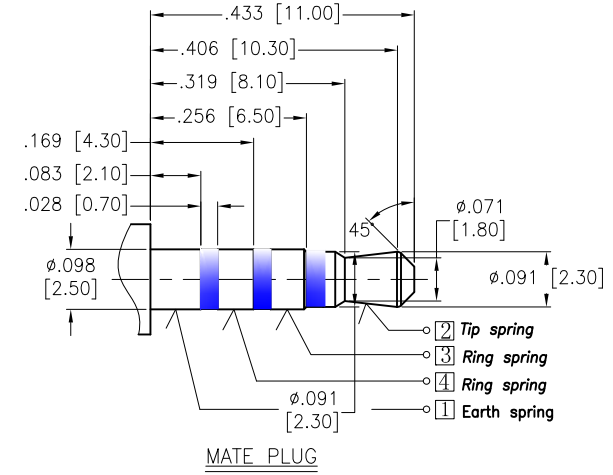
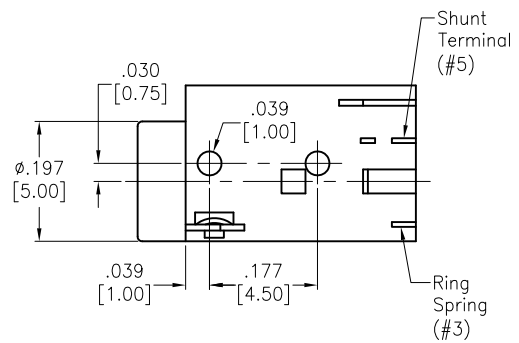

SPECIFICATIONS:
 Material:
 Insulator: PBT, rated UL 94V-0
 Insulator color: Black
 Shunt Terminal (#5): Brass
 Ring Spring (#3): Stainless Steel
 Spring (Other Pin): Phosphor Bronze
 Plating:
 Silver over Copper underplate overall
 Electrical:
 Rating: 30VDC, 0.5A
 Contact resistance: 50 mohms max
 Insulation resistance: 100 Mohms min @ 500 VDC
 Dielectric withstanding voltage: 500 VAC
 Temperature Rating:
 Operating temperature: -20°C to +70°C
 Environmental:
 Lead free, RoHS compliant.



UNLESS OTHERWISE SPECIFIED
 ALL DIMENSIONS ARE INCHES [MM]
 TOLERANCES: EXCEPT AS NOTED

INCHES		HOLES	
.X	± .10	Ø.X	± .10
.XX	± .020	Ø.XX	± .015
.XXX	± .015	Ø.XXX	± .010

APPROVALS		DATE
DRAWN	HR	3/16/18
CHECKED	MY	3/16/18
APPROVED		

ADAM TECH INTERCONNECTS 909 Rahway Avenue, Union, NJ 07083
 Phone: 908-687-5000 Fax: 908-687-5710

TITLE: STEREO JACK, 2.5MM, RIGHT ANGLE
 PCB MOUNT THRU HOLE

SIZE X	PART NO. ASJ-190-X	REV. A
REF: S00002C	SCALE: NTS	SHEET 1 OF 1