

APPROVED: _____
 DATE: _____ TITLE: _____

Rev	AWO #	Description	Date	Appr
-		Released	11/13/12	
A		UPDATE SHAPE	9/11/14	AY/NP
B		UPDATE SPEC.	3/11/15	AY/CH
C		UPDATE SPEC.	4/13/15	HR/LW
D		UPDATE SPEC.	6/17/16	HR/CH

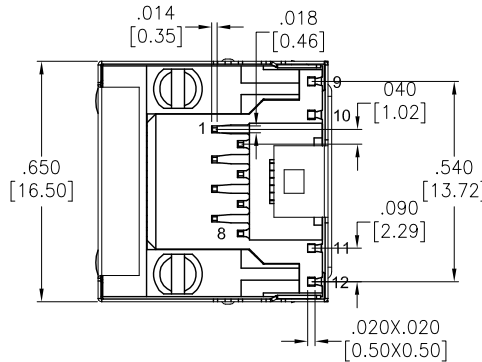
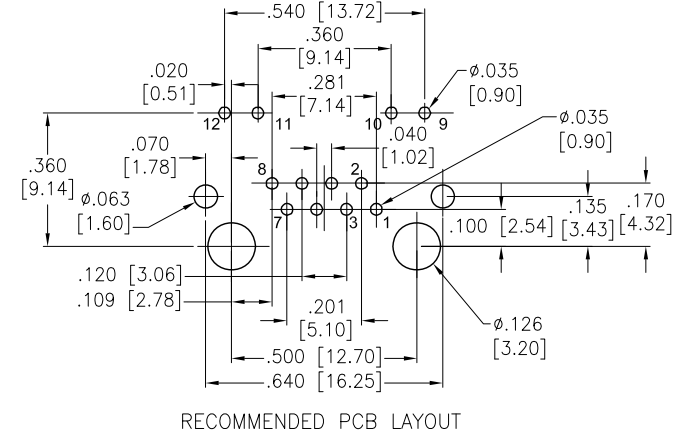
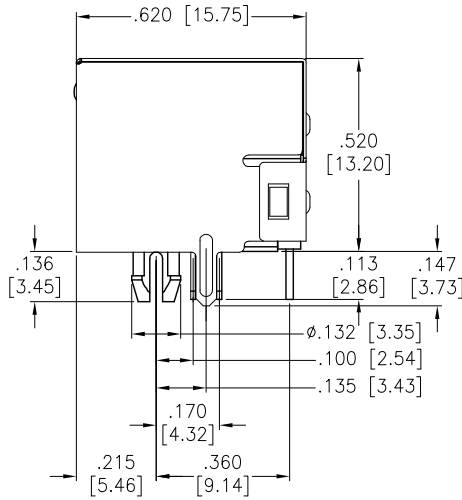
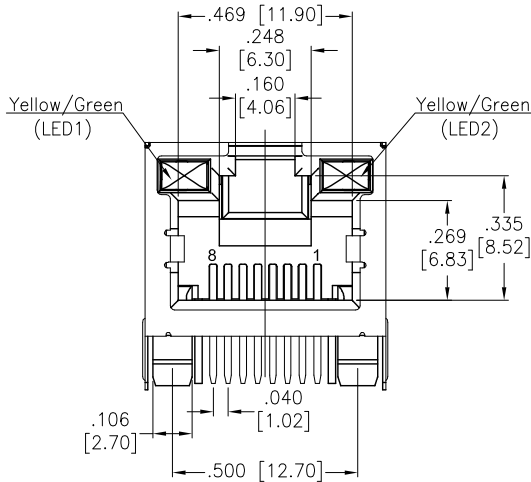

SPECIFICATIONS:

Material:
 Insulator: PBT, glass reinforced, rated UL 94V-0
 Insulator color: Black
 Contacts: Phosphor Bronze
 Shield: Brass, Nickel plated
 Contacts Plating:
 Round contact
 Gold over Nickel underplate overall
 Flat contact
 Gold over Nickel underplate on contact area,
 Tin over Nickel underplate on solder tails
 (See chart for thickness)

Electrical:
 Voltage rating: 150 VAC rms
 Current rating: 1.5 Amps max
 Contact resistance: 20 mohms max. initial
 Insulation resistance: 1000 Mohms min @ 500 VDC
 Dielectric withstanding voltage:
 Contact to Contact: 1,000 VDC or AC Peak for 1 minute
 Contact to Screen and Test panel: 1,500 VDC or AC Peak for 1 minute

Temperature Rating:
 Operating temperature: -40°C to +85°C
 Environmental:
 Lead free, RoHS compliant.



X	PLATING
0	15 uin Gold
1	30 uin Gold
2	50 uin Gold

UNLESS OTHERWISE SPECIFIED ALL DIMENSIONS ARE MM [INCHES] TOLERANCES: EXCEPT AS NOTED		
INCHES HOLES		
.X ± .10	∅X ± .10	
.XX ± .020	∅XX ± .015	
.XXX ± .015	∅XXX ± .010	
APPROVALS		DATE
DRAWN	SLS	11/13/12
CHECKED		
APPROVED		

ADAM TECH
 909 Rahway Avenue, Union, NJ 07083
 Phone: 908-687-5000 Fax: 908-687-0214

TITLE
**MODULAR TELEPHONE JACK, R/A, 8P8C
 YEL/GRN LED1 & YEL/GRN LED2**

SIZE X	PART NO. MTJ-88ARX1-FSM-LP	REV. D
REF: S00005C	SCALE: NTS	SHEET 1 OF 1