

## Advance Information

# Low-Voltage CMOS Quad 2-Input Multiplexer With 5V-Tolerant Inputs (Non-Inverting)

The MC74LCX157 is a high performance, quad 2-input multiplexer operating from a 2.7 to 3.6V supply. High impedance TTL compatible inputs significantly reduce current loading to input drivers while TTL compatible outputs offer improved switching noise performance. A  $V_I$  specification of 5.5V allows MC74LCX157 inputs to be safely driven from 5V devices.

Four bits of data from two sources can be selected using the Select and Enable inputs. The four outputs present the selected data in the true (non-inverted) form. The MC74LCX157 can also be used as a function generator. Current drive capability is 24mA at the outputs.

- Designed for 2.7 to 3.6V  $V_{CC}$  Operation
- 5V Tolerant Inputs — Interface Capability With 5V TTL Logic
- LVTTTL Compatible
- LVCMOS Compatible
- 24mA Balanced Output Sink and Source Capability
- Near Zero Static Supply Current (10 $\mu$ A) Substantially Reduces System Power Requirements
- Latchup Performance Exceeds 500mA
- ESD Performance: Human Body Model >2000V; Machine Model >200V

**Pinout: 16-Lead Plastic Package (Top View)**

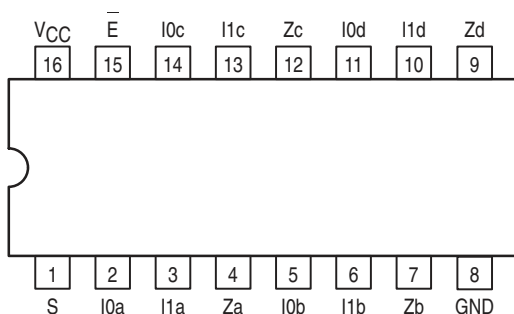

# MC74LCX157

# LCX

**LOW-VOLTAGE CMOS  
QUAD 2-INPUT MULTIPLEXER**

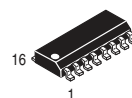

**D SUFFIX**  
PLASTIC SOIC  
CASE 751B-05

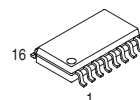

**M SUFFIX**  
PLASTIC SOIC EIAJ  
CASE 966-01

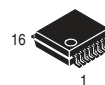

**SD SUFFIX**  
PLASTIC SSOP  
CASE 940B-03

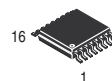

**DT SUFFIX**  
PLASTIC TSSOP  
CASE 948F-01

### PIN NAMES

Pins	Function
I0n	Source 0 Data Inputs
I1n	Source 1 Data Inputs
E	Enable Input
S	Select Input
Zn	Outputs

This document contains information on a new product. Specifications and information herein are subject to change without notice.



LOGIC DIAGRAM

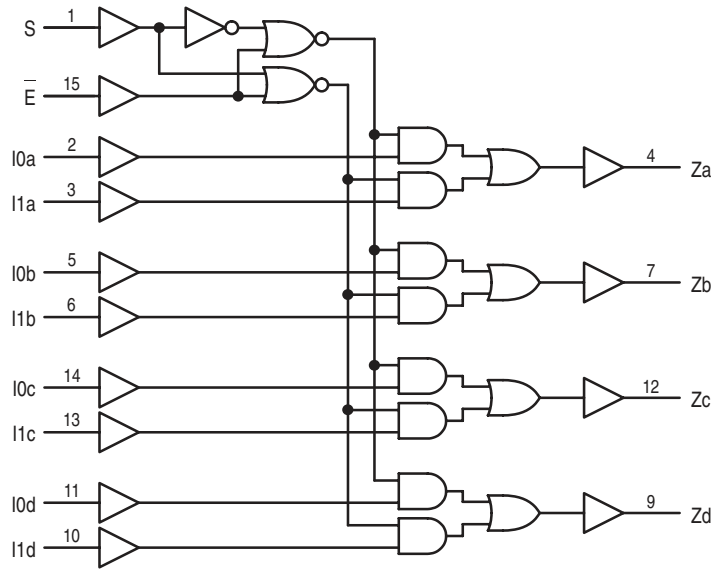

TRUTH TABLE

Inputs				Outputs
$\bar{E}$	S	I0n	I1n	Zn
H	X	X	X	L
L	H	X	L	L
L	H	X	H	H
L	L	L	X	L
L	L	H	X	H

H = High Voltage Level; L = Low Voltage Level; X = High or Low Voltage Level; For I<sub>CC</sub> Reasons DO NOT FLOAT Inputs

## ABSOLUTE MAXIMUM RATINGS\*

Symbol	Parameter	Value	Condition	Unit
V <sub>CC</sub>	DC Supply Voltage	-0.5 to +7.0		V
V <sub>I</sub>	DC Input Voltage	-0.5 ≤ V <sub>I</sub> ≤ +7.0		V
V <sub>O</sub>	DC Output Voltage	-0.5 ≤ V <sub>O</sub> ≤ V <sub>CC</sub> + 0.5	Note 1.	V
I <sub>IK</sub>	DC Input Diode Current	-50	V <sub>I</sub> < GND	mA
I <sub>OK</sub>	DC Output Diode Current	-50	V <sub>O</sub> < GND	mA
		+50	V <sub>O</sub> > V <sub>CC</sub>	mA
I <sub>O</sub>	DC Output Source/Sink Current	±50		mA
I <sub>CC</sub>	DC Supply Current Per Supply Pin	±100		mA
I <sub>GND</sub>	DC Ground Current Per Ground Pin	±100		mA
T <sub>STG</sub>	Storage Temperature Range	-65 to +150		°C

\* Absolute maximum continuous ratings are those values beyond which damage to the device may occur. Exposure to these conditions or conditions beyond those indicated may adversely affect device reliability. Functional operation under absolute-maximum-rated conditions is not implied.

1. Output in HIGH or LOW State. I<sub>O</sub> absolute maximum rating must be observed.

## RECOMMENDED OPERATING CONDITIONS

Symbol	Parameter	Min	Typ	Max	Unit	
V <sub>CC</sub>	Supply Voltage	Operating	2.0	3.3	3.6	V
		Data Retention Only	1.5	3.3	3.6	
V <sub>I</sub>	Input Voltage	0		5.5	V	
V <sub>O</sub>	Output Voltage (HIGH or LOW State)	0		V <sub>CC</sub>	V	
I <sub>OH</sub>	HIGH Level Output Current, V <sub>CC</sub> = 3.0V – 3.6V			-24	mA	
I <sub>OL</sub>	LOW Level Output Current, V <sub>CC</sub> = 3.0V – 3.6V			24	mA	
I <sub>OH</sub>	HIGH Level Output Current, V <sub>CC</sub> = 2.7V – 3.0V			-12	mA	
I <sub>OL</sub>	LOW Level Output Current, V <sub>CC</sub> = 2.7V – 3.0V			12	mA	
T <sub>A</sub>	Operating Free-Air Temperature	-40		+85	°C	
Δt/ΔV	Input Transition Rise or Fall Rate, V <sub>IN</sub> from 0.8V to 2.0V, V <sub>CC</sub> = 3.0V	0		10	ns/V	

## DC ELECTRICAL CHARACTERISTICS

Symbol	Characteristic	Condition	T <sub>A</sub> = -40°C to +85°C		Unit
			Min	Max	
V <sub>IH</sub>	HIGH Level Input Voltage (Note 2.)	2.7V ≤ V <sub>CC</sub> ≤ 3.6V	2.0		V
V <sub>IL</sub>	LOW Level Input Voltage (Note 2.)	2.7V ≤ V <sub>CC</sub> ≤ 3.6V		0.8	V
V <sub>OH</sub>	HIGH Level Output Voltage	2.7V ≤ V <sub>CC</sub> ≤ 3.6V; I <sub>OH</sub> = -100μA	V <sub>CC</sub> - 0.2		V
		V <sub>CC</sub> = 2.7V; I <sub>OH</sub> = -12mA	2.2		
		V <sub>CC</sub> = 3.0V; I <sub>OH</sub> = -18mA	2.4		
		V <sub>CC</sub> = 3.0V; I <sub>OH</sub> = -24mA	2.2		
V <sub>OL</sub>	LOW Level Output Voltage	2.7V ≤ V <sub>CC</sub> ≤ 3.6V; I <sub>OL</sub> = 100μA		0.2	V
		V <sub>CC</sub> = 2.7V; I <sub>OL</sub> = 12mA		0.4	
		V <sub>CC</sub> = 3.0V; I <sub>OL</sub> = 16mA		0.4	
		V <sub>CC</sub> = 3.0V; I <sub>OL</sub> = 24mA		0.55	

2. These values of V<sub>I</sub> are used to test DC electrical characteristics only.

**DC ELECTRICAL CHARACTERISTICS** (continued)

Symbol	Characteristic	Condition	T <sub>A</sub> = -40°C to +85°C		Unit
			Min	Max	
I <sub>I</sub>	Input Leakage Current	2.7V ≤ V <sub>CC</sub> ≤ 3.6V; 0V ≤ V <sub>I</sub> ≤ 5.5V		±5.0	μA
I <sub>CC</sub>	Quiescent Supply Current	2.7 ≤ V <sub>CC</sub> ≤ 3.6V; V <sub>I</sub> = GND or V <sub>CC</sub>		10	μA
		2.7 ≤ V <sub>CC</sub> ≤ 3.6V; 3.6 ≤ V <sub>I</sub> ≤ 5.5V		±10	μA
ΔI <sub>CC</sub>	Increase in I <sub>CC</sub> per Input	2.7 ≤ V <sub>CC</sub> ≤ 3.6V; V <sub>IH</sub> = V <sub>CC</sub> - 0.6V		500	μA

**AC CHARACTERISTICS** (t<sub>R</sub> = t<sub>F</sub> = 2.5ns; C<sub>L</sub> = 50pF; R<sub>L</sub> = 500Ω)

Symbol	Parameter	Waveform	Limits			Unit
			T <sub>A</sub> = -40°C to +85°C			
			V <sub>CC</sub> = 3.0V to 3.6V		V <sub>CC</sub> = 2.7V	
			Min	Max	Max	
t <sub>PLH</sub> t <sub>PHL</sub>	Propagation Delay In to Zn	1	1.5 1.5	5.8 5.8	6.3 6.3	ns
t <sub>PLH</sub> t <sub>PHL</sub>	Propagation Delay S to Zn	1,2	1.5 1.5	7.0 7.0	8.0 8.0	ns
t <sub>PLH</sub> t <sub>PHL</sub>	Propagation Delay E to Zn	2	1.5 1.5	7.0 7.0	8.0 8.0	ns
t <sub>OSHL</sub> t <sub>OSLH</sub>	Output-to-Output Skew (Note 3.)			1.0 1.0		ns

3. Skew is defined as the absolute value of the difference between the actual propagation delay for any two separate outputs of the same device. The specification applies to any outputs switching in the same direction, either HIGH-to-LOW (t<sub>OSHL</sub>) or LOW-to-HIGH (t<sub>OSLH</sub>); parameter guaranteed by design.

**DYNAMIC SWITCHING CHARACTERISTICS**

Symbol	Characteristic	Condition	T <sub>A</sub> = +25°C			Unit
			Min	Typ	Max	
V <sub>OLP</sub>	Dynamic LOW Peak Voltage (Note 4.)	V <sub>CC</sub> = 3.3V, C <sub>L</sub> = 50pF, V <sub>IH</sub> = 3.3V, V <sub>IL</sub> = 0V		0.8		V
V <sub>OLV</sub>	Dynamic LOW Valley Voltage (Note 4.)	V <sub>CC</sub> = 3.3V, C <sub>L</sub> = 50pF, V <sub>IH</sub> = 3.3V, V <sub>IL</sub> = 0V		0.8		V

4. Number of outputs defined as “n”. Measured with “n-1” outputs switching from HIGH-to-LOW or LOW-to-HIGH. The remaining output is measured in the LOW state.

**CAPACITIVE CHARACTERISTICS**

Symbol	Parameter	Condition	Typical	Unit
C <sub>IN</sub>	Input Capacitance	V <sub>CC</sub> = 3.3V, V <sub>I</sub> = 0V or V <sub>CC</sub>	7	pF
C <sub>OUT</sub>	Output Capacitance	V <sub>CC</sub> = 3.3V, V <sub>I</sub> = 0V or V <sub>CC</sub>	8	pF
CPD	Power Dissipation Capacitance	10MHz, V <sub>CC</sub> = 3.3V, V <sub>I</sub> = 0V or V <sub>CC</sub>	25	pF

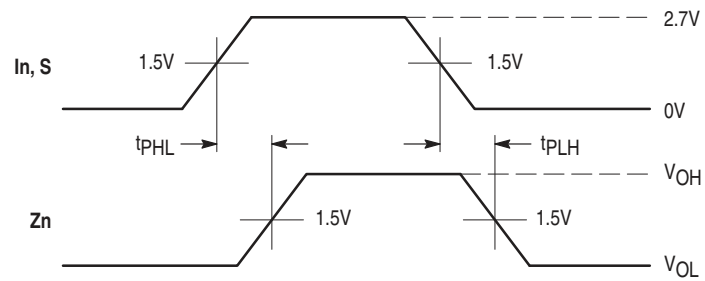

**WAVEFORM 1 – NON-INVERTING PROPAGATION DELAYS**  
 $t_R = t_F = 2.5\text{ns}$ , 10% to 90%;  $f = 1\text{MHz}$ ;  $t_W = 500\text{ns}$

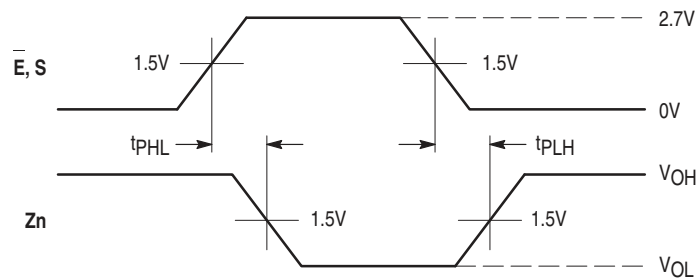

**WAVEFORM 2 – INVERTING PROPAGATION DELAYS**  
 $t_R = t_F = 2.5\text{ns}$ , 10% to 90%;  $f = 1\text{MHz}$ ;  $t_W = 500\text{ns}$

**Figure 1. AC Waveforms**

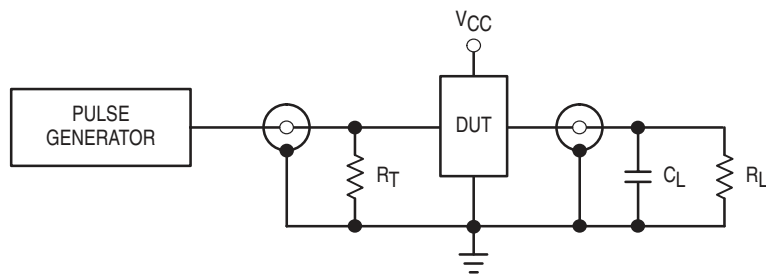

$C_L = 50\text{pF}$  or equivalent (Includes jig and probe capacitance)  
 $R_L = R_1 = 500\Omega$  or equivalent  
 $R_T = Z_{OUT}$  of pulse generator (typically  $50\Omega$ )

**Figure 2. Test Circuit**

# Low Voltage Cross Reference to Motorola's Low Voltage Logic Families

Company	Family	Pkg Code	Package	Motorola Replacement	Pkg Code	Comments
TI	SN74LVTxxx	D	JEDEC SOIC	<i>MC74LCXxxx</i>	D	LCX has lower drive, but less power
TI	SN74LVTxxx	DB	5.3 mm SSOP II	<i>MC74LCXxxx</i>	SD	LCX has lower drive, but less power
TI	SN74LVTxxx	DW	Wide JEDEC SOIC	<i>MC74LCXxxx</i>	DW	LCX has lower drive, but less power
TI	SN74LVTxxx	PW	4.4 mm TSSOP	<i>MC74LCXxxx</i>	DT	LCX has lower drive, but less power
TI	SN74LVT16xxx	DL	48/56 7.5 mm SSOP			Use TSSOP. Not footprint compatible
TI	SN74LVT16xxx	DGG	48/56 6.1 mm TSSOP	<i>MC74LCX16xxx</i>	DT	LCX has lower drive, but less power
TI	SN74LVCxxx	D	JEDEC SOIC	<b>MC74LCXxxx</b>	D	Direct replacement. LVC has no Power down High-Z feature. Many are NOT 5V-tolerant
TI	SN74LVCxxx	DB	5.3 mm SSOP II	<b>MC74LCXxxx</b>	SD	Direct replacement. LVC has no Power down High-Z feature. Many are NOT 5V-tolerant
TI	SN74LVCxxx	DW	Wide JEDEC SOIC	<b>MC74LCXxxx</b>	DW	Direct replacement. LVC has no Power down High-Z feature. Many are NOT 5V-tolerant
TI	SN74LVCxxx	PW	4.4 mm TSSOP	<b>MC74LCXxxx</b>	DT	Direct replacement. LVC has no Power down High-Z feature. Many are NOT 5V-tolerant
TI	SN74LVC16xxx	DL	48/56 7.5 mm SSOP			Use TSSOP. Not footprint compatible
TI	SN74LVC16xxx	DGG	48/56 6.1 mm TSSOP	<b>MC74LCX16xxx</b>	DT	Direct replacement. LVC has no Power down High-Z feature. Many are NOT 5V-tolerant
TI	SN74LVC4245	DB	5.3 mm SSOP II			Use TSSOP. Not footprint compatible
TI	SN74LVC4245	DW	Wide JEDEC SOIC	<i>MC74LVX4245</i>	DW	Similar replacement
TI	SN74LVC4245	PW	4.4 mm TSSOP	<i>MC74LVX4245</i>	DT	Similar replacement
TI	SN74ALVC16xxx	DL	48/56 7.5 mm SSOP			Use TSSOP. Not footprint compatible
TI	SN74ALVC16xxx	DGG	48/56 6.1 mm TSSOP	<i>MC74LCX16xxx</i>	DT	ALVC is slightly faster, but LCX16xxx offers 5V tolerance
TI	SN74LVxxx	D	JEDEC SOIC	<i>MC74LVXxxx</i>	D	LVX has 4mA drive vs. 6mA for LV. LVX is much faster and has 5V tolerant inputs. Alternate: 74LVQxxx
TI	SN74LVxxx	DB	5.3 mm SSOP II		SD	For LVX, use TSSOP. Not footprint compatible. Alternate: 74LVQxxx
TI	SN74LVxxx	DW	Wide JEDEC SOIC	<i>MC74LVXxxx</i>	DW	LVX has 4mA drive vs. 6mA for LV. LVX is much faster and has 5V tolerant inputs. Alternate: 74LVQxxx
TI	SN74LVxxx	PW	4.4 mm TSSOP	<i>MC74LVXxxx</i>	DT	LVX has 4mA drive vs. 6mA for LV. LVX is much faster and has 5V tolerant inputs. Alternate: 74LVQxxx
Philips	74LVTxxx	D	JEDEC SOIC	<i>MC74LCXxxx</i>	D	LCX has lower drive, but less power
Philips	74LVTxxx	DB	5.3 mm SSOP II	<i>MC74LCXxxx</i>	SD	LCX has lower drive, but less power
Philips	74LVTxxx	D	Wide JEDEC SOIC	<i>MC74LCXxxx</i>	DW	LCX has lower drive, but less power
Philips	74LVTxxx	PW	4.4 mm TSSOP	<i>MC74LCXxxx</i>	DT	LCX has lower drive, but less power
Philips	74LVT16xxx	DL	48/56 7.5 mm SSOP			Use TSSOP. Not footprint compatible
Philips	74LVT16xxx	DGG	48/56 6.1 mm TSSOP	<i>MC74LCX16xxx</i>	DT	LCX has lower drive, but less power
Philips	74LVCxxx	D	JEDEC SOIC	<b>MC74LCXxxx</b>	D	Direct replacement. Many LVC are NOT 5V-tolerant
Philips	74LVCxxx	DB	5.3 mm SSOP II	<b>MC74LCXxxx</b>	SD	Direct replacement. Many LVC are NOT 5V-tolerant
Philips	74LVCxxx	D	Wide JEDEC SOIC	<b>MC74LCXxxx</b>	DW	Direct replacement. Many LVC are NOT 5V-tolerant
Philips	74LVCxxx	PW	4.4 mm TSSOP	<b>MC74LCXxxx</b>	DT	Direct replacement. Many LVC are NOT 5V-tolerant
Philips	74LVC16xxx	DL	48/56 7.5 mm SSOP			Use TSSOP. Not footprint compatible
Philips	74LVC16xxx	DGG	48/56 6.1 mm TSSOP	<b>MC74LCX16xxx</b>	DT	Direct replacement. Many LVC are NOT 5V-tolerant
Philips	74LVC4245	DB	5.3 mm SSOP II			Use TSSOP. Not footprint compatible
Philips	74LVC4245	D	Wide JEDEC SOIC	<i>MC74LVX4245</i>	DW	Similar replacement

NOTE: Motorola cannot guarantee device compatibility and assumes no liability for device incompatibility either implied or stated in this Cross Reference Guide. Compatibility must be verified by the user.

**Bold:** Direct replacement (See above Note); *Italics:* Similar replacement; Blank: Either no replacement or no footprint compatible package.

# Low Voltage Cross Reference

Company	Family	Pkg Code	Package	Motorola Replacement	Pkg Code	Comments
Philips	74LVC4245	PW	4.4 mm TSSOP	<i>MC74LVX4245</i>	DT	Similar replacement
Philips	74ALVC16xxx	DL	48/56 7.5 mm SSOP			Use TSSOP. Not footprint compatible
Philips	74ALVC16xxx	DGG	48/56 6.1 mm TSSOP	<i>MC74LCX16xxx</i>	DT	ALVC is slightly faster, but LCX16xxx offers 5V tolerance
Philips	74LVxxx	N	PDIP	<i>MC74LVXxxx</i>	N	LVX has 4mA drive vs. 6mA for LV. LVX is much faster and has 5V tolerant inputs
Philips	74LVxxx	D	JEDEC SOIC	<i>MC74LVXxxx</i>	D	LVX has 4mA drive vs. 6mA for LV. LVX is much faster and has 5V tolerant inputs. Alternate: 74LVQxxx
Philips	74LVxxx	DB	5.3 mm SSOP II		SD	For LVX, use TSSOP. Not footprint compatible. Alternate: 74LVQxxx
Philips	74LVxxx	D	Wide JEDEC SOIC	<i>MC74LVXxxx</i>	DW	LVX has 4mA drive vs. 6mA for LV. LVX is much faster and has 5V tolerant inputs Alternate: 74LVQxxx
Philips	74LVxxx	PW	4.4 mm TSSOP	<i>MC74LVXxxx</i>	DT	LVX has 4mA drive vs. 6mA for LV. LVX is much faster and has 5V tolerant inputs. Alternate: 74LVQxxx
IDT	IDT74FCT3xxx	P	PDIP			Use SOIC. Not footprint compatible
IDT	IDT74FCT3xxx	SO	Wide JEDEC SOIC	<b>MC74LCXxxx</b>	DW	Direct replacement. LCX also features 5V tolerance
IDT	IDT74FCT3xxx	PY	5.3 mm SSOP II	<b>MC74LCXxxx</b>	SD	Direct replacement. LCX also features 5V tolerance
IDT	IDT74FCT163xxx	PV	48/56 7.5 mm SSOP			Use TSSOP. Not footprint compatible
IDT	IDT74FCT163xxx	PA	48/56 6.1 mm TSSOP	<b>MC74LCX16xxx</b>	DT	Direct replacement. LCX also features 5V tolerance
IDT	IDT74FCT3xxxA	P	PDIP			Use SOIC. Not footprint compatible
IDT	IDT74FCT3xxxA	SO	Wide JEDEC SOIC	<i>MC74LCXxxx</i>	DW	FCT3...A slightly faster, but LCX offers 5V tolerance
IDT	IDT74FCT3xxxA	PY	5.3 mm SSOP II	<i>MC74LCXxxx</i>	SD	FCT3...A slightly faster, but LCX offers 5V tolerance
IDT	IDT74FCT163xxxA	PV	48/56 7.5 mm SSOP			Use TSSOP. Not footprint compatible
IDT	IDT74FCT163xxxA	PA	48/56 6.1 mm TSSOP	<b>MC74LCX16xxx</b>	DT	Direct replacement. LCX also features 5V tolerance
Pericom	PI74FCT163xxx	V	48/56 7.5 mm SSOP			Use TSSOP. Not footprint compatible
Pericom	PI74FCT163xxx	A	48/56 6.1 mm TSSOP	<b>MC74LCX16xxx</b>	DT	Direct replacement. LCX also features 5V tolerance
Pericom	PI74FCT163xxxA	V	48/56 7.5 mm SSOP			Use TSSOP. Not footprint compatible
Pericom	PI74FCT163xxxA	A	48/56 6.1 mm TSSOP	<b>MC74LCX16xxx</b>	DT	Direct replacement. LCX also features 5V tolerance
Pericom	PI74LPTxxx	W	JEDEC SOIC	<b>MC74LCXxxx</b>	D	Direct replacement. LCX also features power down high-Z
Pericom	PI74LPTxxx	S	Wide JEDEC SOIC	<b>MC74LCXxxx</b>	DW	Direct replacement. LCX also features power down high-Z
Pericom	PI74LPTxxx	Q	QSOP			Use TSSOP. Not footprint compatible
Pericom	PI74LPTxxx	R	Thin QSOP			Use TSSOP. Not footprint compatible
Pericom	PI74LPTxxx	L	4.4 mm TSSOP	<b>MC74LCXxxx</b>	DT	Direct replacement. LCX also features power down high-Z
Pericom	PI74LPTxxxA/C	W	JEDEC SOIC	<i>MC74LCXxxx</i>	D	LPT...A/C slightly faster
Pericom	PI74LPTxxxA/C	S	Wide JEDEC SOIC	<i>MC74LCXxxx</i>	DW	LPT...A/C slightly faster
Pericom	PI74LPTxxxA/C	Q	QSOP			Use TSSOP. Not footprint compatible
Pericom	PI74LPTxxxA/C	R	Thin QSOP			Use TSSOP. Not footprint compatible
Pericom	PI74LPTxxxA/C	L	4.4 mm TSSOP	<i>MC74LCXxxx</i>	DT	LPT...A/C slightly faster
Pericom	PI74LPT16xxx/A/C	V	48/56 7.5 mm SSOP			Use TSSOP. Not footprint compatible
Pericom	PI74LPT16xxx/A/C	A	48/56 6.1 mm TSSOP	<b>MC74LCX16xxx</b>	DT	Direct replacement
Pericom	PI74LCXxxx	W	JEDEC SOIC	<b>MC74LCXxxx</b>	D	Direct replacement
Pericom	PI74LCXxxx	S	Wide JEDEC SOIC	<b>MC74LCXxxx</b>	DW	Direct replacement
Pericom	PI74LCXxxx	L	4.4 mm TSSOP	<b>MC74LCXxxx</b>	DT	Direct replacement
Pericom	PI74LCX16xxx	A	48/56 6.1 mm TSSOP	<b>MC74LCX16xxx</b>	DT	Direct replacement
Quality Semi	QS74FCT3xxx	SO	Wide JEDEC SOIC	<b>MC74LCXxxx</b>	DW	Direct replacement. LCX also features power down high-Z

NOTE: Motorola cannot guarantee device compatibility and assumes no liability for device incompatibility either implied or stated in this Cross Reference Guide. Compatibility must be verified by the user.

**Bold:** Direct replacement (See above Note); *Italics:* Similar replacement; Blank: Either no replacement or no footprint compatible package.

Company	Family	Pkg Code	Package	Motorola Replacement	Pkg Code	Comments
Quality Semi	QS74FCT3xxx	Q	QSOP			Use TSSOP. Not footprint compatible
Quality Semi	QS74FCT3xxxA	SO	Wide JEDEC SOIC	<i>MC74LCXxxx</i>	DW	FCT3...A slightly faster, but LCX offers 5V tolerance
Quality Semi	QS74FCT3xxxA	Q	QSOP			Use TSSOP. Not footprint compatible
Quality Semi	QS74FCT163xxxA	Q2	QVSOP			Use TSSOP. Not footprint compatible. LCX also features power down high-Z
Quality Semi	QS74LCXxxx	SO	Wide JEDEC SOIC	<b>MC74LCXxxx</b>	DW	Direct replacement. Careful, QSI may not be spec compatible to LCX
Quality Semi	QS74LCXxxx	Q	QSOP			Use TSSOP. Not footprint compatible
Quality Semi	QS74LCX16xxx	Q2	QVSOP			Use TSSOP. Careful, QSI may not be spec compatible to LCX
Toshiba	TC74LCXxxx	FN	JEDEC SOIC	<b>MC74LCXxxx</b>	D	Direct replacement
Toshiba	TC74LCXxxx	FW	Wide JEDEC SOIC	<b>MC74LCXxxx</b>	DW	Direct replacement
Toshiba	TC74LCXxxx	F	EIAJ SOIC	<b>MC74LCXxxx</b>	M	Direct replacement
Toshiba	TC74LCXxxx	FS	4.4 mm SSOP I	<b>MC74LCXxxx</b>	DT	Direct replacement. TSSOP is footprint compatible with this SSOP
Toshiba	TC74LCX16xxx	FT	48/56 6.1 mm TSSOP	<b>MC74LCX16xxx</b>	DT	Direct replacement
Toshiba	TC74LVXxxx	FN	JEDEC SOIC	<b>MC74LVXxxx</b>	D	Direct replacement
Toshiba	TC74LVXxxx	FW	Wide JEDEC SOIC	<b>MC74LVXxxx</b>	DW	Direct replacement
Toshiba	TC74LVXxxx	F	EIAJ SOIC I	<b>MC74LVXxxx</b>	M	Direct replacement
Toshiba	TC74LVXxxx	FS	4.4 mm SSOP	<b>MC74LVXxxx</b>	DT	Direct replacement. TSSOP is footprint compatible with this SSOP
Toshiba	TC74LVQxxx	FN	JEDEC SOIC	<b>MC74LVQxxx</b>	D	Direct replacement
Toshiba	TC74LVQxxx	FW	Wide JEDEC SOIC	<b>MC74LVQxxx</b>	DW	Direct replacement
Toshiba	TC74LVQxxx	F	EIAJ SOIC	<b>MC74LVQxxx</b>	M	Direct replacement
Toshiba	TC74LVQxxx	FS	4.4 mm SSOP I	<b>MC74LVQxxx</b>	DT	Direct replacement. TSSOP is footprint compatible with this SSOP
Toshiba	TC74LVX4245	FS	4.4 mm SSOP I	<b>MC74LVX4245</b>	DT	Direct replacement. TSSOP is footprint compatible with this SSOP
National	74LCXxxx	M	JEDEC SOIC	<b>MC74LCXxxx</b>	D	Direct replacement
National	74LCXxxx	MSA	5.3 mm SSOP II	<b>MC74LCXxxx</b>	SD	Direct replacement
National	74LCXxxx	WM	Wide JEDEC SOIC	<b>MC74LCXxxx</b>	DW	Direct replacement
National	74LCXxxx	SJ	EIAJ SOIC	<b>MC74LCXxxx</b>	M	Direct replacement
National	74LCXxxx	MTC	4.4 mm TSSOP	<b>MC74LCXxxx</b>	DT	Direct replacement
National	74LCX16xxx	MEA	48/56 7.5 mm SSOP			Use TSSOP. Not footprint compatible
National	74LCX16xxx	MTD	48/56 6.1 mm TSSOP	<b>MC74LCX16xxx</b>	DT	Direct replacement
National	74LVXxxx	M	JEDEC SOIC	<b>MC74LVXxxx</b>	D	Direct replacement
National	74LVXxxx	WM	Wide JEDEC SOIC	<b>MC74LVXxxx</b>	DW	Direct replacement
National	74LVXxxx	SJ	EIAJ SOIC	<b>MC74LVXxxx</b>	M	Direct replacement
National	74LVXxxx	MTC	4.4 mm TSSOP	<b>MC74LVXxxx</b>	DT	Direct replacement
National	74LVQxxx	M	JEDEC SOIC	<b>MC74LVQxxx</b>	D	Direct replacement
National	74LVQxxx	WM	Wide JEDEC SOIC	<b>MC74LVQxxx</b>	DW	Direct replacement
National	74LVQxxx	SJ	EIAJ SOIC	<b>MC74LVQxxx</b>	M	Direct replacement
National	74LVQxxx	QSC	QSOP			Use TSSOP. Not footprint compatible
National	74LVX4245	M	JEDEC SOIC	<b>MC74LVX4245</b>	D	Direct replacement
National	74LVX4245	MTC	4.4 mm TSSOP	<b>MC74LVX4245</b>	DT	Direct replacement

NOTE: Motorola cannot guarantee device compatibility and assumes no liability for device incompatibility either implied or stated in this Cross Reference Guide. Compatibility must be verified by the user.

**Bold:** Direct replacement (See above Note); *Italics:* Similar replacement; Blank: Either no replacement or no footprint compatible package.



# Introducing LCX

## Motorola's Low-Voltage CMOS Logic Family

Motorola's 3V LCX family features 5V-tolerant inputs and outputs that enable easy transition from 5V to mixed 3V/5V systems or to 3V systems. Low power, low switching noise and fast switching speeds make this family perfect for low power portable applications as well as high-end, advanced workstation applications.

The unique feature of this family is its ability to interface to pure 3V or both 3V and 5V buses in the same design without sacrificing performance. The LCX family improves system performance by drastically reducing static and dynamic power consumption which extends battery life for portable and handheld applications. Customers also realize simplified system design in mixed voltage environments, as well as expedited development of their low voltage systems. The 3V/5V interface using LCX, requires no other special components that would be necessary to protect other low voltage logic families that cannot tolerate signals beyond the  $V_{CC}$  supply level.

The Motorola LCX family is available in industry standard JEDEC SOIC, EIAJ SOIC, SSOP type 2, and TSSOP packages. LCX family specifications range from  $-40^{\circ}\text{C}$  to  $+85^{\circ}\text{C}$ . The LCX family was developed in accordance with an alliance including Motorola and two other major semiconductor suppliers, so there are alternate sources available now.

- Designed for 2.7 to 3.6V  $V_{CC}$  Operation
- 5V Tolerant — Interface Capability With 5V TTL Logic
- Supports Live Insertion/Withdrawal (3-State Devices)
- $I_{OFF}$  Specification Guarantees High Impedance When  $V_{CC} = 0\text{V}$  (3-State Devices)
- LVTTTL Compatible
- LVCMOS Compatible
- 24mA Balanced Output Sink and Source Capability
- Near Zero Static Supply Current in All Three Logic States ( $10\mu\text{A}$ ) Substantially Reduces System Power Requirements
- Latchup Performance Exceeds 500mA
- ESD Performance: Human Body Model  $>2000\text{V}$ ; Machine Model  $>200\text{V}$

## LCX Family Specifications

To assist the designer in evaluating the performance of Motorola's LCX family, data specifications and actual performance information are included here.

### ABSOLUTE MAXIMUM RATINGS\*

Symbol	Parameter	Value	Condition	Unit
$V_{CC}$	DC Supply Voltage	$-0.5$ to $+7.0$		V
$V_I$	DC Input Voltage	$-0.5 \leq V_I \leq +7.0$		V
$V_O$	DC Output Voltage	$-0.5 \leq V_O \leq +7.0$	Output in 3-State	V
		$-0.5 \leq V_O \leq V_{CC} + 0.5$	Note 1.	V
$I_{IK}$	DC Input Diode Current	$-50$	$V_I < \text{GND}$	mA
$I_{OK}$	DC Output Diode Current	$-50$	$V_O < \text{GND}$	mA
		$+50$	$V_O > V_{CC}$	mA
$I_O$	DC Output Source/Sink Current	$\pm 50$		mA
$I_{CC}$	DC Supply Current Per Supply Pin	$\pm 100$		mA
$I_{GND}$	DC Ground Current Per Ground Pin	$\pm 100$		mA
$T_{STG}$	Storage Temperature Range	$-65$ to $+150$		$^{\circ}\text{C}$

\* Absolute maximum continuous ratings are those values beyond which damage to the device may occur. Exposure to these conditions or conditions beyond those indicated may adversely affect device reliability. Functional operation under absolute-maximum-rated conditions is not implied.

1. Output in HIGH or LOW State.  $I_O$  absolute maximum rating must be observed.

**RECOMMENDED OPERATING CONDITIONS**

Symbol	Parameter	Min	Typ	Max	Unit
V <sub>CC</sub>	Supply Voltage	Operating	3.3	3.6	V
		Data Retention Only	1.5	3.6	
V <sub>I</sub>	Input Voltage	0		5.5	V
V <sub>O</sub>	Output Voltage (HIGH or LOW State) (3-State)			V <sub>CC</sub>	V
				5.5	
I <sub>OH</sub>	HIGH Level Output Current, V <sub>CC</sub> = 3.0V – 3.6V			–24	mA
I <sub>OL</sub>	LOW Level Output Current, V <sub>CC</sub> = 3.0V – 3.6V			24	mA
I <sub>OH</sub>	HIGH Level Output Current, V <sub>CC</sub> = 2.7V – 3.0V			–12	mA
I <sub>OL</sub>	LOW Level Output Current, V <sub>CC</sub> = 2.7V – 3.0V			12	mA
T <sub>A</sub>	Operating Free-Air Temperature	–40		+85	°C
Δt/ΔV	Input Transition Rise or Fall Rate, V <sub>IN</sub> from 0.8V to 2.0V, V <sub>CC</sub> = 3.0V	0		10	ns/V

**DC ELECTRICAL CHARACTERISTICS**

Symbol	Characteristic	Condition	T <sub>A</sub> = –40°C to +85°C		Unit
			Min	Max	
V <sub>IH</sub>	HIGH Level Input Voltage (Note 2.)	2.7V ≤ V <sub>CC</sub> ≤ 3.6V	2.0		V
V <sub>IL</sub>	LOW Level Input Voltage (Note 2.)	2.7V ≤ V <sub>CC</sub> ≤ 3.6V		0.8	V
V <sub>OH</sub>	HIGH Level Output Voltage	2.7V ≤ V <sub>CC</sub> ≤ 3.6V; I <sub>OH</sub> = –100μA	V <sub>CC</sub> – 0.2		V
		V <sub>CC</sub> = 2.7V; I <sub>OH</sub> = –12mA	2.2		
		V <sub>CC</sub> = 3.0V; I <sub>OH</sub> = –18mA	2.4		
		V <sub>CC</sub> = 3.0V; I <sub>OH</sub> = –24mA	2.2		
V <sub>OL</sub>	LOW Level Output Voltage	2.7V ≤ V <sub>CC</sub> ≤ 3.6V; I <sub>OL</sub> = 100μA		0.2	V
		V <sub>CC</sub> = 2.7V; I <sub>OL</sub> = 12mA		0.4	
		V <sub>CC</sub> = 3.0V; I <sub>OL</sub> = 16mA		0.4	
		V <sub>CC</sub> = 3.0V; I <sub>OL</sub> = 24mA		0.55	
I <sub>I</sub>	Input Leakage Current	2.7V ≤ V <sub>CC</sub> ≤ 3.6V; 0V ≤ V <sub>I</sub> ≤ 5.5V		±5.0	μA
I <sub>OZ</sub>	3-State Output Current	2.7 ≤ V <sub>CC</sub> ≤ 3.6V; 0V ≤ V <sub>O</sub> ≤ 5.5V; V <sub>I</sub> = V <sub>IH</sub> or V <sub>IL</sub>		±5.0	μA
I <sub>OFF</sub>	Power-Off Leakage Current (Note 3.)	V <sub>CC</sub> = 0V; V <sub>I</sub> or V <sub>O</sub> = 5.5V		10	μA
I <sub>CC</sub>	Quiescent Supply Current	2.7 ≤ V <sub>CC</sub> ≤ 3.6V; V <sub>I</sub> = GND or V <sub>CC</sub>		10	μA
		2.7 ≤ V <sub>CC</sub> ≤ 3.6V; 3.6 ≤ V <sub>I</sub> or V <sub>O</sub> ≤ 5.5V		±10	μA
ΔI <sub>CC</sub>	Increase in I <sub>CC</sub> per Input	2.7 ≤ V <sub>CC</sub> ≤ 3.6V; V <sub>IH</sub> = V <sub>CC</sub> – 0.6V		500	μA

2. These values of V<sub>I</sub> are used to test DC electrical characteristics only.

3. I<sub>OFF</sub> is applicable only to devices with 3-state outputs.

**DYNAMIC SWITCHING CHARACTERISTICS**

Symbol	Characteristic	Condition	T <sub>A</sub> = +25°C			Unit
			Min	Typ	Max	
V <sub>OLP</sub>	Dynamic LOW Peak Voltage (Note 4.)	V <sub>CC</sub> = 3.3V, C <sub>L</sub> = 50pF, V <sub>IH</sub> = 3.3V, V <sub>IL</sub> = 0V		0.8		V
V <sub>OLV</sub>	Dynamic LOW Valley Voltage (Note 4.)	V <sub>CC</sub> = 3.3V, C <sub>L</sub> = 50pF, V <sub>IH</sub> = 3.3V, V <sub>IL</sub> = 0V		0.8		V

4. Number of outputs defined as “n”. Measured with “n–1” outputs switching from HIGH-to-LOW or LOW-to-HIGH. The remaining output is measured in the LOW state.

## CAPACITIVE CHARACTERISTICS

Symbol	Parameter	Condition	Typical	Unit
C <sub>IN</sub>	Input Capacitance	V <sub>CC</sub> = 3.3V, V <sub>I</sub> = 0V or V <sub>CC</sub>	7	pF
C <sub>OUT</sub>	Output Capacitance	V <sub>CC</sub> = 3.3V, V <sub>I</sub> = 0V or V <sub>CC</sub>	8	pF
C <sub>I/O</sub>	Input/Output Capacitance (Note 5.)	V <sub>CC</sub> = 3.3V, V <sub>I</sub> = 0V or V <sub>CC</sub>	8	pF
C <sub>PD</sub>	Power Dissipation Capacitance	10MHz, V <sub>CC</sub> = 3.3V, V <sub>I</sub> = 0V or V <sub>CC</sub>	Note 6.	pF

- 5. Bidirectional devices only.
- 6. Function dependent, see individual datasheets.

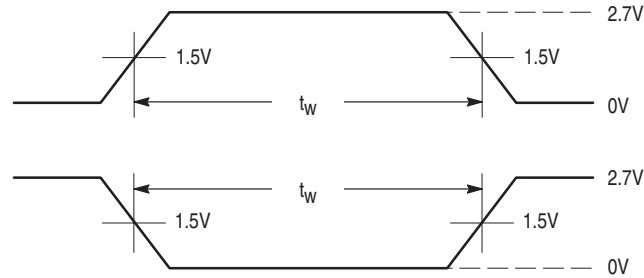

**PULSE WIDTH**  
 $t_R = t_F = 2.5\text{ns}$  (or fast as required) from 10% to 90%;  
 Output requirements:  $V_{OL} \leq 0.8\text{V}$ ,  $V_{OH} \geq 2.0\text{V}$

**Figure 1. LCX AC Waveforms**

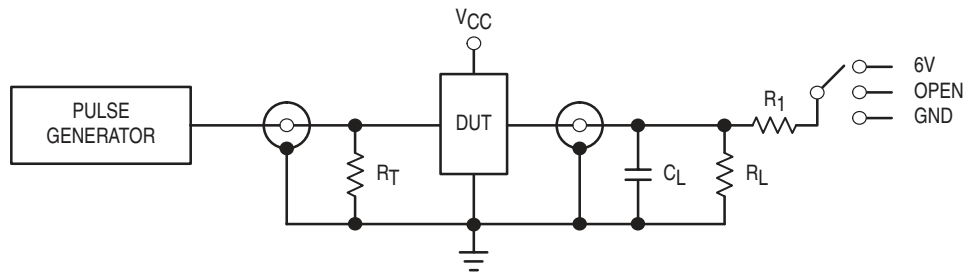

TEST	SWITCH
t <sub>PLH</sub> , t <sub>PHL</sub>	Open
t <sub>PZL</sub> , t <sub>PLZ</sub>	6V
Open Collector/Drain t <sub>PLH</sub> and t <sub>PHL</sub>	6V
t <sub>PZH</sub> , t <sub>PHZ</sub>	GND

C<sub>L</sub> = 50pF or equivalent (Includes jig and probe capacitance)  
 R<sub>L</sub> = R<sub>1</sub> = 500Ω or equivalent  
 R<sub>T</sub> = Z<sub>OUT</sub> of pulse generator (typically 50Ω)

**Figure 2. LCX Test Circuit**

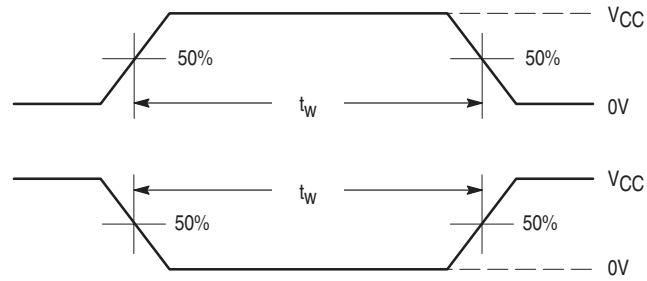

**PULSE WIDTH**  
 $t_R = t_F = 2.5\text{ns}$  (or fast as required) from 10% to 90%;  
 Output requirements:  $V_{OL} \leq 0.8\text{V}$ ,  $V_{OH} \geq 2.0\text{V}$

Figure 3. LVX AC Waveforms

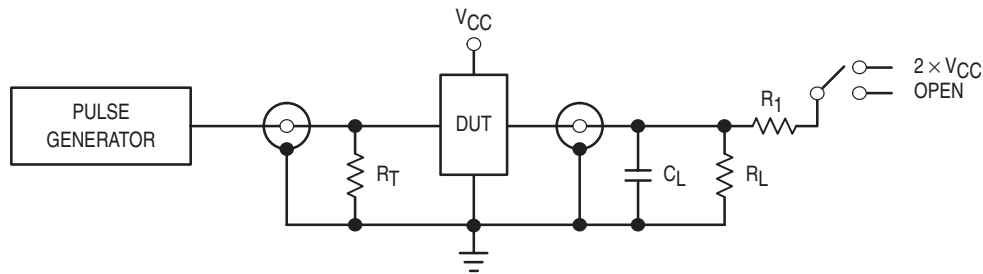

TEST	SWITCH
$t_{PLH}$ , $t_{PHL}$ , $t_{PZH}$ , $t_{PHZ}$	Open
$t_{PZL}$ , $t_{PLZ}$	$2 \times V_{CC}$

$C_L = 50\text{pF}$  or equivalent (Includes jig and probe capacitance)  
 $R_L = R_1 = 500\Omega$  or equivalent  
 $R_T = Z_{OUT}$  of pulse generator (typically  $50\Omega$ )

Figure 4. LVX Test Circuit

LCXxxx Devices

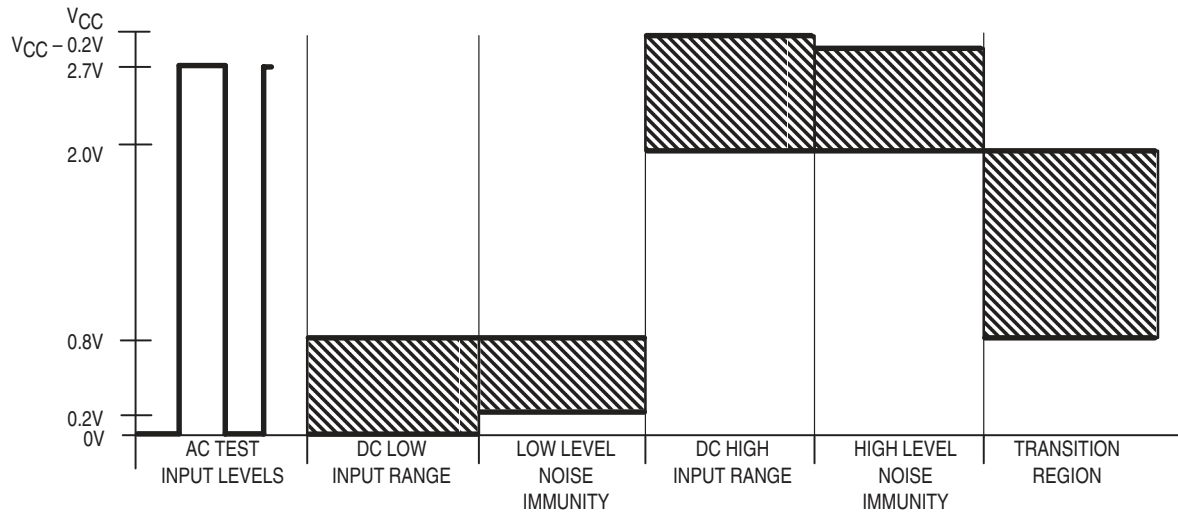

Figure 5. Test Input Signal Levels

## Test Conditions

Figure 5 describes the input signal voltage levels to be used when testing LCX circuits. The AC test conditions follow industry convention requiring  $V_{IN}$  to range from 0 V for a logic LOW to 2.7V for a logic HIGH. The DC parameters are normally tested with  $V_I$  at guaranteed input levels, that is  $V_{IH}$  to  $V_{IL}$  (see datasheets for details). Care must be taken to adequately decouple these high performance parts and to protect the test signals from electrical noise. In an electrically noisy environment, (e.g., a tester and handler not specifically designed for high speed work), DC input levels may need adjustment to increase the noise margin allowance for the tester. This noise will not likely be seen in a system environment.

Noise immunity testing is performed by raising  $V_I$  to the nominal supply voltage of 3.3V then dropping to a level corresponding to  $V_{IH}$  characteristics, and then raising it again to the 3.3V level. Noise tests are performed on the  $V_{IL}$  characteristics by raising  $V_I$  from 0 V to  $V_{IL}$ , then returning to 0 V. Both  $V_{IH}$  and  $V_{IL}$  noise immunity tests should not induce a switch condition on the appropriate outputs of the LCX device.

Good high frequency wiring practices should be used in constructing test jigs. Leads on the load capacitor should be as short as possible to minimize ripples on the output wave form transitions and to minimize undershoot. Generous ground metal (preferably a ground plane) should be used for the same reasons. A  $V_{CC}$  bypass capacitor should be provided at the test socket, also with minimum lead lengths.

## Rise and Fall Times

Input signals should have rise and fall times of 2.5ns or less (10% to 90%), and signal swing of 0V to 2.7V. Rise and fall times less than or equal to 1ns should be used for testing  $f_{max}$  or pulse widths.

CMOS devices tend to oscillate when the input rise and fall times become lengthy. As a direct result of its increased performance, LCX devices can be more sensitive to slow input rise and fall times than other lower performance technologies. Recommended edge rate is  $\leq 10\text{ns/V}$ .

It is important to understand why this oscillation occurs. Consider the outputs, where the problem is initiated. Usually, CMOS outputs drive capacitive loads with low DC leakage. When the output changes from a HIGH level to a LOW level, or from a LOW level to a HIGH level, this capacitance is charged or discharged. With the present high performance technologies, charging or discharging takes place in a very short time, typically 2–3ns. The requirement to charge or discharge the capacitive loads quickly creates a condition where the instantaneous current change through the output structure is quite high. A voltage is generated across the  $V_{CC}$  or ground leads inside the package due to the lead inductance. The internal ground of the chip will change in reference to the outside world because of this induced voltage.

Next, consider the inputs. If the internal ground changes, the input voltage level appears to change to the DUT. If the input rise time is slow enough, its level might still be in the threshold region, or very close to it, when the output switches. If the internally-induced voltage is large enough, it is possible to shift the threshold enough so that it re-crosses the input level. If the gain of the device is sufficient and the input rise or

fall time is slow enough, then the device may go into oscillation. As device propagation delays become shorter, the inputs will have less time to rise or fall through the threshold region. As device gains increase, the outputs will swing more, creating more induced voltage. Instantaneous current change will be greater as outputs become quicker, generating more induced voltage.

Package-related causes of output oscillation are not entirely to blame for problems with input rise and fall time measurements. All testers have  $V_{CC}$  and ground leads with some finite inductance. This inductance must be added to the inductance of the package to determine the overall voltage which will be induced when the outputs change. As the reference for the input signals moves further away from the pin under test, the test will be more susceptible to problems caused by the inductance of the leads and stray noise. Any noise on the input signal will also cause problems.

## Enable and Disable Times

Figure 9 and Figure 10 show that the disable times are measured at the point where the output voltage has risen or fallen by 0.3V from the voltage rail level (i.e., ground for  $t_{PLZ}$  or  $V_{CC}$  for  $t_{PHZ}$ ). This change enhances the repeatability of measurements, reduces test times, and gives the system designer more realistic delay times to use in calculating minimum cycle times. Since the high-impedance state rising or falling waveform is RC-controlled, the first 0.3V of change is more linear and is less susceptible to external influences. More importantly, perhaps from the system designer's point of view, a change in voltage of 0.3V is adequate to ensure that a device output has turned OFF. Measuring to a larger change in voltage merely exaggerates the apparent Disable time artificially penalizing system performance (since the designer must use the Enable and Disable times to figure worst case timing.)

## Propagation Delay, $f_{max}$ , Set, Hold, and Recovery Times

A 1 MHz square wave is recommended for most propagation delay tests. The repetition rate must necessarily be increased for testing  $f_{max}$ . A 50% duty cycle should always be used when testing  $f_{max}$ . Two pulse generators are usually required for testing such parameters as setup time ( $t_s$ ), hold time ( $t_h$ ), recovery time ( $t_{REC}$ ) shown in Figure 8.

## Electrostatic Discharge

Precautions should be taken to prevent damage to devices by electrostatic discharge. Static charge tends to accumulate on insulated surfaces such as synthetic fabrics or carpeting, plastic sheets, trays, foam, tubes or bags, and on ungrounded electrical tools or appliances. The problem is much worse in a dry atmosphere. In general, it is recommended that individuals take the precaution of touching a known ground before handling devices. To effectively avoid electrostatic damage to LCX devices, it is recommended that individuals wear a grounded wrist strap when handling devices. More often, handling equipment, which is not properly grounded, causes damage to parts. Ensure that all plastic parts of the tester, which are near the device, are conductive and connected to ground.

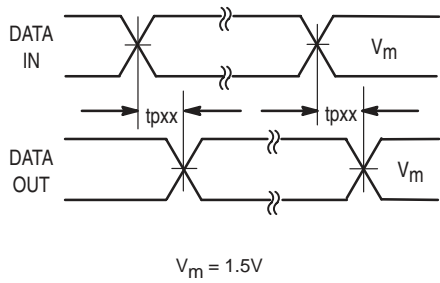

Figure 6. Waveform for Inverting and Non-Inverting Functions

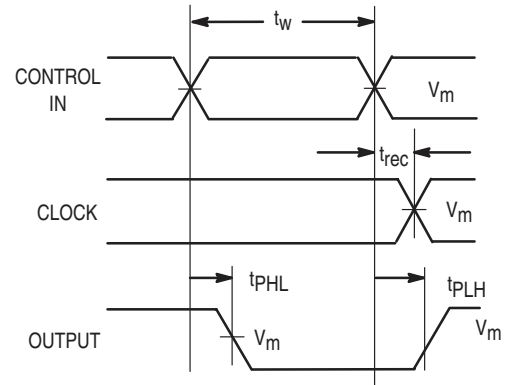

Figure 7. Propagational Delay, Pulse Width and  $t_{rec}$  Waveforms

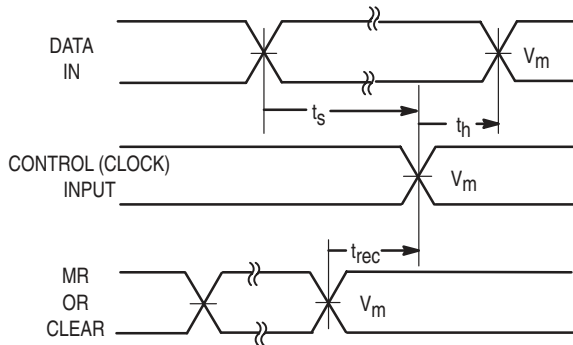

Figure 8. Setup Time, Hold Time and Recovery Time

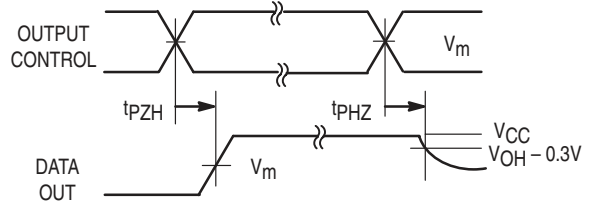

Figure 9. 3-State Output High Enable and Disable Times

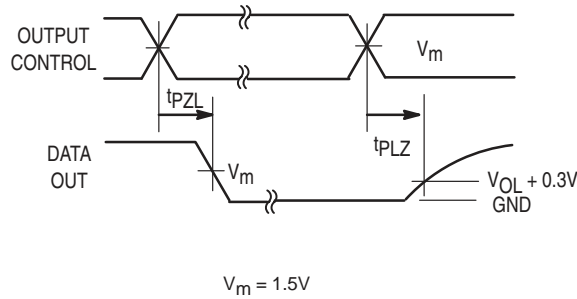

Figure 10. 3-State Output Low Enable and Disable Times

# Definitions of Symbols

## DC Characteristics

Currents	Positive current is defined as conventional current flow into a device. Negative current is defined as current flow out of a device.
Voltages	All voltages are referenced to the ground pin.
$I_{CC}$	The current flowing into the $V_{CC}$ supply terminal when the device is at a quiescent state.
$I_{CCH}$	The current flowing into the $V_{CC}$ supply terminal when the outputs are in the HIGH state.
$I_{CCL}$	The current flowing into the $V_{CC}$ supply terminal when the outputs are in the LOW state.
$I_{CCZ}$	The current flowing into the $V_{CC}$ supply terminal when the outputs are disabled (high impedance).
$\Delta I_{CC}$	Additional $I_{CC}$ due to TTL HIGH levels ( $V_{CC} - 0.6V$ ) forced on CMOS inputs.
$I_I$	Input Current. The current flowing into or out of an input when a specified LOW or HIGH voltage is applied to that input.
$I_{OH}$	Output HIGH Current. The current flowing out of an output which is in the HIGH state.
$I_{OL}$	Output LOW Current. The current flowing into an output which is in the LOW state.
$I_{OS}$	Output Short Circuit Current. The current flowing out of an output in the HIGH state when that output is shorted to ground (or other specified potential).
$I_{OZ}$	Output high impedance current. The current flowing into or out of a disabled output when specified LOW or HIGH voltage is applied to that output.
$I_{OFF}$	Input/Output power-off leakage current. The maximum leakage current into or out of the input/output transistors when forcing the input/output from 0V to 5.5V with $V_{CC} = 0V$ .
$V_{CC}$	Supply Voltage. The range of power supply voltages over which the device is guaranteed to operate.
$V_{IH}$	Input HIGH Voltage. The minimum input voltage that is recognized as a DC HIGH level.
$V_{IL}$	Input LOW Voltage. The maximum input voltage that is recognized as a DC LOW level.
$V_{OH}$	Output HIGH Voltage. The voltage at an output conditioned HIGH with a specified output load and $V_{CC}$ supply voltage.
$V_{OL}$	Output LOW Voltage. The voltage at an output conditioned LOW with a specified output load and $V_{CC}$ supply voltage.
$V_{OLP}$	Maximum (peak) voltage induced on a static LOW output during switching of other outputs.
$V_{OLV}$	Minimum (valley) voltage induced on a static LOW output during switching of other outputs.

## AC Characteristics

$f_{max}$ Toggle Frequency/Operating Frequency	– The maximum rate at which clock pulses may be applied to a sequential circuit. Above this frequency the device may cease to function properly.
$t_{PLH}$ Propagation Delay Time	– The time between the specified reference points, on the input and output voltage waveforms, with the output changing from the defined LOW level to the defined HIGH level.
$t_{PHL}$ Propagation Delay Time	– The time between the specified reference points, on the input and output voltage waveforms, with the output changing from the defined HIGH level to the defined LOW level.
$t_W$ Pulse Width	– The time between specified amplitude points of the leading and trailing edges of a pulse.
$t_H$ Hold Time	– The interval immediately following the active transition of the timing pulse (usually the clock pulse) or following the transition of the control input to its latching level, during which interval the data to be recognized must be maintained at the input to ensure its continued recognition.
$t_S$ Setup Time	– The interval immediately preceding the active transition of the timing pulse (usually the clock pulse) or preceding the transition of the control input to its latching level, during which interval the data to be recognized must be maintained at the input to ensure its recognition.
$t_{PHZ}$ Output Disable Time (of a 3-state Output) from HIGH Level	– The time between specified levels on the input and a voltage 0.3V below the steady state output HIGH level with the 3-state output changing from the defined HIGH level to a high impedance (OFF) state.
$t_{PLZ}$ Output Disable Time (of a 3-state Output) from LOW Level	– The time between specified levels on the input and a voltage 0.3V above the steady state output LOW level with the 3-state output changing from the defined LOW level to a high impedance (OFF) state.
$t_{pZH}$ Output Enable Time (of a 3-state Output) to a HIGH Level	– The time between the specified levels of the input and output voltage waveforms with the 3-state output changing from a high impedance (OFF) state to a HIGH level.
$t_{pZL}$ Output Enable Time (of a 3-state Output) to a LOW Level	– The time between the specified levels of the input and output voltage waveforms with the 3-state output changing from a high impedance (OFF) state to a LOW level.
$t_{rec}$ Recovery Time	– The time between the specified level on the trailing edge of an asynchronous input control pulse and the same level on a synchronous input (clock) pulse such that the device will respond to the synchronous input.

# LCX Family Characteristics

## LCX and LVT Products

Product Family	74LCX244	74LVC244A	74LVT244A
Technology	CMOS	CMOS	BiCMOS
I <sub>CCL</sub> (mA)	0.01	0.01	12.0
I <sub>CC</sub> vs Frequency (50MHz)	130mA	145mA	275mA
Speed	6.5ns	6.5ns	4.1ns
Drive (2.0V/0.55V) JEDEC (2.4V/0.4V)	>-24mA/24mA -18mA/16mA	-24mA/24mA -12mA/???	-32mA/64mA -8mA/16mA
5V Tolerant Inputs Outputs	YES YES	YES YES	YES YES*
Power-Down High-Z (I <sub>OFF</sub> )	YES (10μA)	NO	YES (±100μA)
Data Retention	YES	YES	NO

\* LVT claims, but does not specify, 5V-Tolerant outputs. LCX can be used to replace LVC; be careful when exchanging LCX with LVC as not all LVC functions have 5V-tolerance!!

The following graph compares the 5V-tolerance capability of LCX, LVC and LVT. When LCX is not driving the bus (outputs are disabled), the levels on that bus can exceed the LCX V<sub>CC</sub> with no adverse effect on the device or any loading on the bus. In fact, test data shows that a disabled LCX output can “tolerate” signals over 13V on the outputs!

### 5V Output Tolerance

(I<sub>OZ</sub> vs V<sub>out</sub>, V<sub>CC</sub> = 2.7V, +25°C)

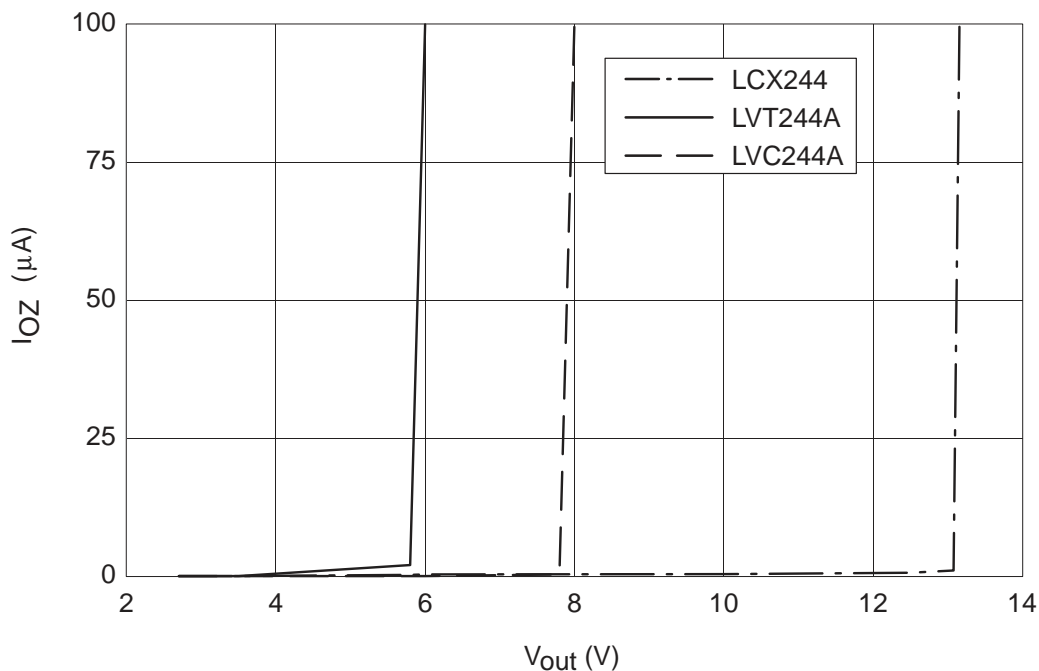



## LCX Family Characteristics

Another advantage of the LCX family is the low dynamic current. Low dynamic current means low power consumption. Low power consumption means smaller power supplies, longer battery life and physically smaller systems. The following graph shows the Motorola 74LCX245's  $I_{CC}$  vs. Frequency performance with 8 outputs switching. To give an idea of power improvement that can be had with low voltage logic, a 74LCX245 consumes about the same power running at 35MHz that a 74F245 does statically. At 100MHz the LCX device only consumes about 200mA.

### ICC versus Frequency

(25°C, 3.3V)

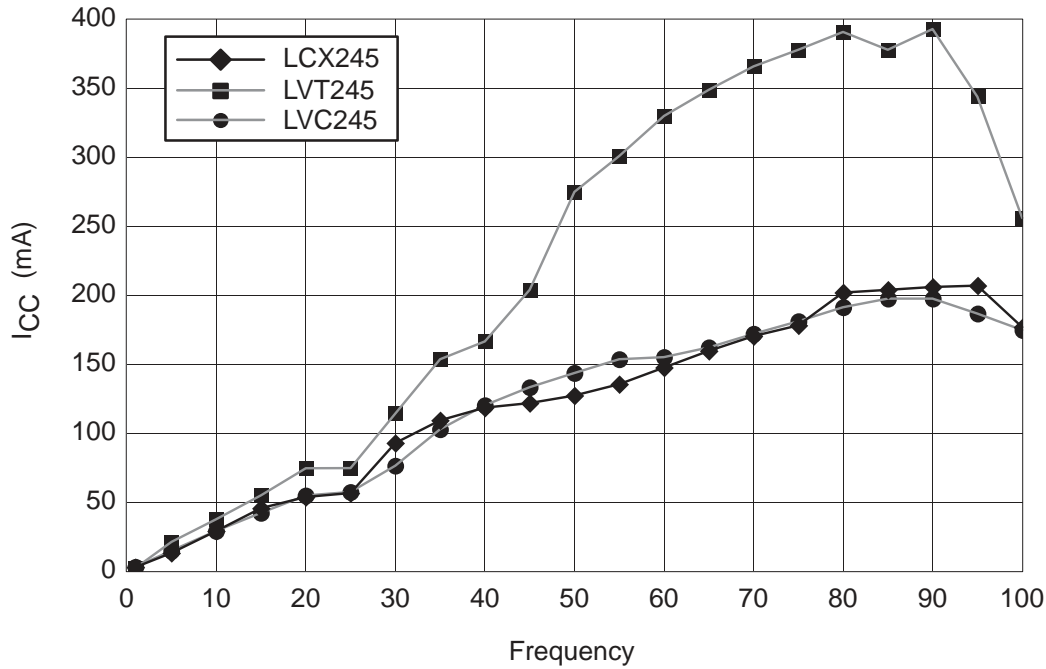

**LCX — Low-Voltage CMOS Logic (With 5V-Tolerant Inputs and Outputs)**

The LCX family represents Motorola’s Low-Voltage CMOS family. These devices offer mixed 3V–5V capability and are recommended for applications where 3.3V and 5V subsystems interface with one another and where low power consumption is a necessity. The input and output (Note 1) structures of the LCX family of products will tolerate input and output node exposure to signals or DC levels that exceed the  $V_{CC}$  level (Note 2). Refer to Figure 11 for schematic description of a typical LCX circuit. Note that the output PMOS device P1 has its bulk potential supplied by the output of the comparator X1 rather than by  $V_{CC}$  as in conventional CMOS. The circuitry contained within the comparator is designed such that the output is always the greater of  $V_{CC}$  or  $V_O$ . This technique circumvents the P+/N– bulk–source forward junction that usually appears between the PMOS drain at the output and the bulk connection of the output PMOS which is usually tied to  $V_{CC}$ . Eliminating this junction is fundamental to the powered–down high Z and overvoltage tolerance features that distinguish Motorola’s LCX family from other Low-Voltage CMOS products.

NOTE 1: U.S. Patent 5,451,889.

NOTE 2: Output overvoltage is permitted unconditionally for 3–stated outputs. For active outputs, see datasheet.

**LVX-Low Voltage Dual Supply Translating Transceivers**

In applications where 3.3V signals must be “stepped up” to 5V, in order to interface full swing CMOS busses, LCX may not be the proper solution. The LVX translating transceiver designs have an entirely different approach to solve the

mixed supply interface problem. These devices are not overvoltage tolerant, but rather true voltage translators — meaning that they receive 3V signals and output 5V signals, and receive 5V signals and output 3V signals (which can also be accomplished with LCX). This is done by dividing the devices internally so that the A–side circuitry is isolated from the B–side circuitry. The dual supply architecture allows the LVX translators to interface 3V and 5V signals with near–zero static power dissipation.

The MC74LVX4245 A–side is dedicated to 5V operation, with  $V_{CCA}$  specified over the 4.5V–5.5V range. The B–side is dedicated to 3.3V, with  $V_{CCB}$  specified over the 2.7V–3.6V range.

The MC74LVXC3245 offers enhanced interfacing features. The B–side is designed to operate over an extended range of I/O and supply levels. The  $V_{CCB}$  is permitted to be set to any value between 2.7V and 5.5V. The I/O levels on the B–side will track or scale automatically according to the level set on  $V_{CCB}$ . The B–side operation is completely independent of  $V_{CCA}$ . The A–port and control input buffers are referenced to  $V_{CCA}$ , totally independent of  $V_{CCB}$ . The configurable dual supply translating transceiver, LVXC3245, is designed to tolerate floating inputs on the B–port when  $V_{CCA}$  and the control signals are set to valid operating levels. The combination of this on–the–fly interface flexibility together with “empty socket” tolerance is intended to benefit designers of PC card systems (or PCMCIA) where expansion cards with different supply potentials must be accommodated.

The LVX dual supply translators offer switching speeds equivalent to 5V FCT/FAST but with low ground noise and very low power dissipation.

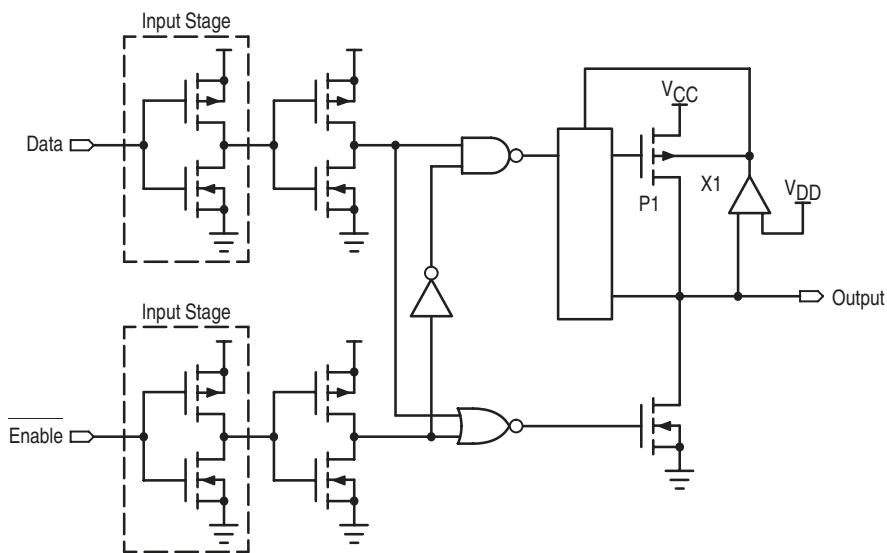

Figure 11. Simplified LCX Schematic Diagram

# LCX Applications Information

## Introduction

Many system designers concerned about reducing power in mobile computing and communications are unnecessarily avoiding the use of 3.3V products because of either cost or the dreaded 3V/5V interface. Cost may be a concern, but nearly every new 3.3V device has better performance – either increased speed, reduced power, or both – when compared to a 5V “counterpart”. In the long run it could easily cost the equipment maker more to continue with older technology rather than make the move to 3.3V or mixed 3.3V/5V systems.

There are three major reasons that chip manufacturers are accelerating the introduction of low voltage devices. First—DRAM manufacturers are worried about damage to products with fine geometries. As memory becomes more dense, feature geometries by necessity shrink. Voltages as high as 5V would damage these compactly designed RAMs. Second—as processor manufacturers have increased the performance of their chips, they have found that packages could not handle the increased power dissipation need. The enabling factor was to move to 3.3V supplies. Power dissipation varies roughly by the ratio of the squares of the  $V_{CC}$ s, ( $P_D \equiv (V_{CC}^2)(\text{capacitance})(\text{frequency})$ ), so the ratio of reduction in power is  $3.3^2/5^2$  (11/25) when moving from 5V to 3.3V. Third—Battery-powered system manufactures are continually working for extended battery life. Obviously a 56+% reduction in power would considerably extend battery life. There are other benefits as well. Smaller packaging can be used to house the low voltage chips—saving board space and making the end product smaller and lighter. Smaller or fewer power supplies are required, and costly, space-hogging heat dissipating equipment can be eliminated.

Most 3.3V logic families can directly interface with only 3.3V products. LVC, LVX, VHC, LVQ/FACT AC, FCT3, and HC product families are lines that may work well for pure 3.3V system interface. Of these families only LVX and redesigned LVC guarantee 5V-tolerant inputs. The other families can tolerate maximum input and output levels of only  $V_{CC}+0.5V$ . If a 5V TTL bus voltage swings to levels that exceed these specifications then the non 5V-tolerant products may be damaged, destroyed, load the bus, or current may be sourced into the 3.3V supply. Not only is it important to be 5V-tolerant on the inputs but to be 5V-tolerant on the outputs as well.

The LCX logic family provides the necessary circuitry to bridge the technology gap between the 5V and 3.3V worlds. The inputs of this low voltage family can be safely driven to 5.5V, guaranteed, easily handling a 5V TTL or 5V CMOS interface on the input bus. When the LCX device outputs, or I/Os, have finished their tasks and are in the high-impedance state, the voltage levels on the bus to which they are tied may rise well above the 3.3V  $V_{CC}$ , up to 5.5V without loading the bus or causing damage to the device or power supply, guaranteed. This capability has been properly termed 5V

*tolerant*, rather than 3.3V/5V translation which is a misnomer. (Products that are powered by 3.3V supplies do not drive 5V rail-to-rail output swings. Dual 3.3V/5V supply devices are needed to drive 5V CMOS level outputs. See 74LVXC3245 and 74LVX4245—translating transceivers.)

There is no longer reason to fear mixed voltage designs. The LCX CMOS family is available now to help you bridge the 3.3V–5V interface.

## Interfacing Dual Systems

To properly interface between integrated circuits, it is imperative that input and output specifications be reviewed and voltage and current levels satisfied. Output specifications ( $V_{OH}$  and  $V_{OL}$ ) of the driving device must meet or exceed the input requirements ( $V_{IH}$  and  $V_{IL}$ ) of the receiving device for the interface to function properly. Meeting these requirements protects against malfunction when operating at different environments which may induce noise to the interface.

The 5V power supply has been the standard for many years in the IC world. Several product families have been introduced with varying speeds, drive capabilities, and power requirements. Because of this many I/O standards have evolved complicating the interface between 5V devices. The move to 3.3V power supplies actually simplifies the interface problem. Pure Bipolar products cannot function at 3.3V, so the core technology is either BiCMOS or pure CMOS. In a pure 3.3V MOS environment the interface can be made directly—inputs and outputs. However, it will be several years before all system components operate from 3.3V supplies. This is especially true for peripheral devices such as printers, displays, and faxes.

## Interfacing 5V–TTL to Pure 3.3V Logic (No 5V–Tolerance)

When the desired interface is 5V–TTL to pure 3.3V CMOS (such as FACT AC or LVQ), the solution becomes a little messy. The designer must make sure that the 5V–TTL outputs do not exceed the 3.3V CMOS input specifications. There are a few options available to protect the 3.3V device from excessive input current. The 3.3V and 5V power supplies should be regulated together. It would also be a benefit to run the 5V supply on the low side reducing the  $V_{CC}-V_{OH}$  difference. If, however, the power supplies are not regulated together and the supplies end up at 5V+10% and 3.3V–10% then the CMOS input specifications would likely be violated. To keep within the CMOS input specification the 5V–TTL output cannot exceed  $0.5V + V_{CC}$  of the CMOS device. The simplest way to insure that  $V_{OH}$  remains within the input specification of the CMOS part is to use a parallel termination resistor tied to ground. There are also CMOS switches that can be placed between the 5V and 3.3V devices to reduce the  $V_{OH}$ , but this solution is very expensive.

### Interfacing 5V–CMOS to Pure 3.3V Logic (No 5V–Tolerance)

When the interface is a 5V CMOS device and a 3.3V CMOS device *without 5V–tolerance*, the problem is much the same as with the 5V–TTL interface—but worse. The output of the 5V device must be reduced or large currents will flow into the 3.3V device. This type of interface is simply not recommended.

### Interfacing Pure 3.3V Logic to 5V Inputs (No 5V Output Tolerance)

Interfacing 3.3V CMOS to 5V–TTL inputs can be done directly. LVCMOS/LVTTL output specifications and 5V–TTL input specifications are compatible. However, when interfacing pure 3.3V parts (no 5V–tolerance) to a 5V bus there is no protection against 5V signals when the 3.3V output is disabled. If the 5V bus voltage levels exceed the  $V_{CC}$  of the 3.3V device, leakage current into the 3.3V device will occur—loading the bus. Also, be aware of 5V buses with pull–up resistors. If pull–up resistors are used then pull–down resistors may be necessary to compensate and reduce the high voltage level to within the  $0.5V + V_{CC}$  range of the 3.3V device. Interfacing a 3.3V CMOS output to a 5V CMOS input is discouraged. The output swing of the 3.3V device is insufficient to reliably drive the 5V CMOS device without the assistance of a pull–up resistor. If a pull–up resistor to 5V  $V_{CC}$  is used to raise the input level to the required  $V_{IH}=3.15V$  (for  $V_{CC}=5V$ , higher for higher  $V_{CC}$ s) then a massive current flow may result into the 3.3V device.

### Interfacing to 5V–Tolerant LCX CMOS Logic

Many of the problems and concerns associated with pure 3.3V interface can be resolved simply by using 5V–tolerant LCX CMOS Logic. LCX tolerates 5V–TTL or 5V CMOS levels on its inputs. There is no inherent leakage path that can damage the device or in any way adversely affect this interface.

The 5V–tolerant output feature protects the 3.3V bus from high signal excursions on the 5V bus when the 3.3V bus is inactive (3–State). Only LCX devices with 3–State capability have 5V–tolerant outputs. Gates and MSI products without 3–State have 5V–tolerant inputs but not 5V–tolerant outputs. When an LCX device is enabled, the 5V output tolerance is not active and will not protect the LCX device in cases of bus

contention. Care must be taken to ensure that the LCX device is 3–Stated when there are 5V signals present on the bus.

Five volt signals can also be caused by the use of pull–ups on the 5V bus. Similarly, certain 5V devices with internal pull–ups may cause leakage current into an LCX enabled output. Pay close attention to the 5V device input specification to see if there are input pull–ups to a 5V supply. LCX can drive a 5V–TTL input even if that input has an internal pull–up, but the user should be aware that when driving this type of input, some leakage current into the low voltage supply will occur. The value of this current,  $I_O$ , is simply the 5V supply voltage value minus the 3.3V supply voltage value divided by the pull–up resistor value. ( $I_O=(V_{CC5}-V_{CC3})/R_{PU}$ ). If the pull–up resistor is 10Kohms for example, the resultant current would be  $1.7V/10K=170\mu A$  per output. In this case, there would be no reliability concern. The specified Absolute Maximum  $I_{CC}/I_{GND}$  Current (100mA per supply/ground pin) must also be considered. For an octal device, the current resulting from a pull–up to 5V must be limited to  $100mA/8$  outputs = 12.5mA/output. 12.5mA, using 5V and 3.3V supplies, would necessitate limiting the pull–up value to 136 ohms. Not until the 12.5mA/output value is approached would there begin to be a chip reliability concern. It is assumed that a low–voltage design power budget would be spent long before the Absolute Maximum  $I_{CC}/I_{GND}$  Current specification would come into play.

An LCX output is not recommended to drive a 5V CMOS input. As noted in the previous section, the  $V_{OH}$  level of the LCX output is not High enough to reliably drive a 5V CMOS input. (Either an open–drain output device or dual supply translator is recommended to drive a 5V CMOS input.)

### LCX Makes Power Management Easy

LCX also offers an advanced feature which can be used to isolate powered–down subsystems from active 3.3V or 5V buses. The LCX'  $I_{OFF}$  specification guarantees, when the LCX'  $V_{CC} = 0V$  and the voltage present on the LCX' output,  $V_O$ , is 5.5V or less, that the LCX' output will sink less than  $10\mu A$  (typically the value is  $< 1\mu A$ ). In other words, when  $V_{CC} = 0V$ , LCX is still 5V–tolerant on both the inputs and outputs. Using this feature a system designer can use LCX to buffer powered–down sections of a board, from active sections, easily implementing advanced power management. See Figure 13.

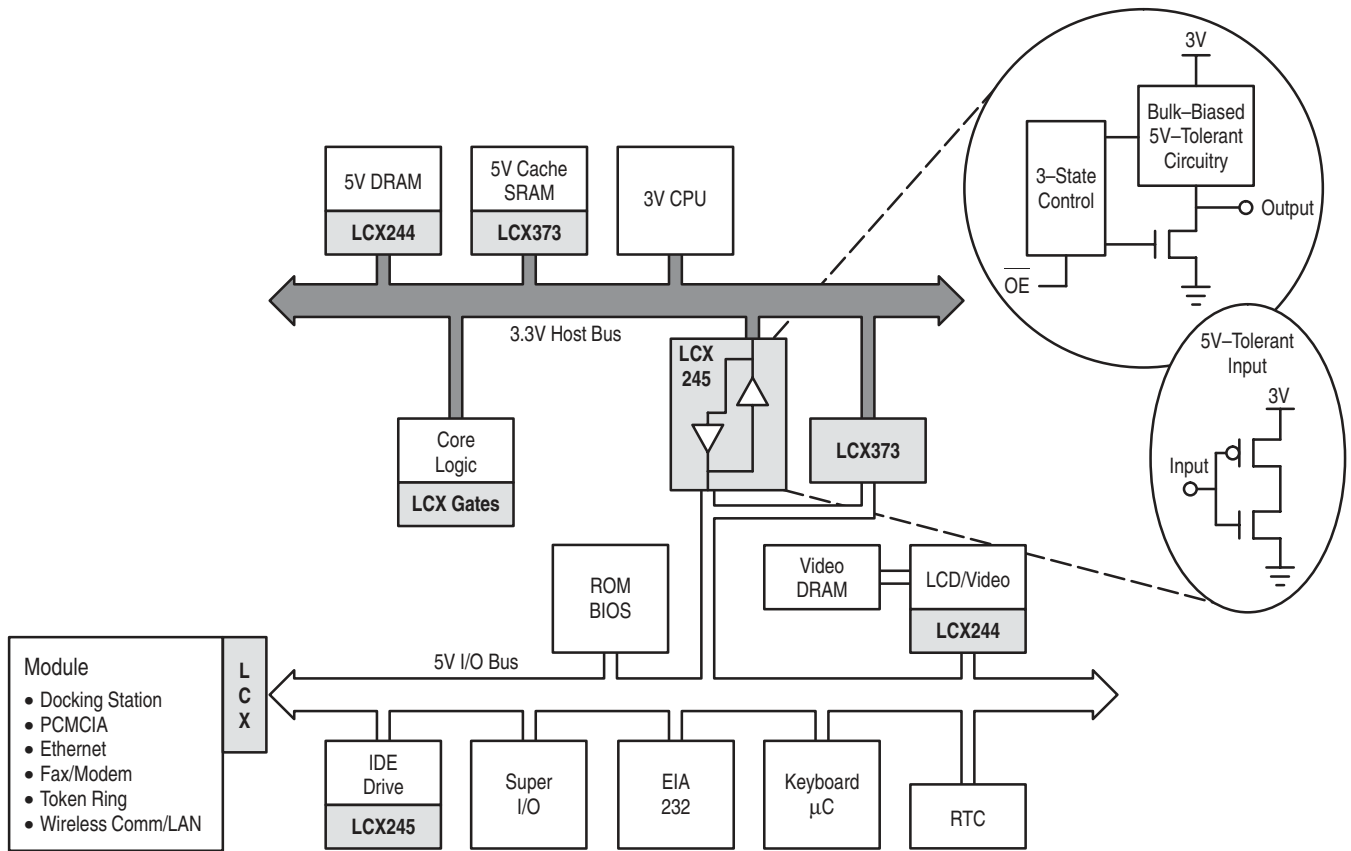

Figure 12. LCX System Block Diagram

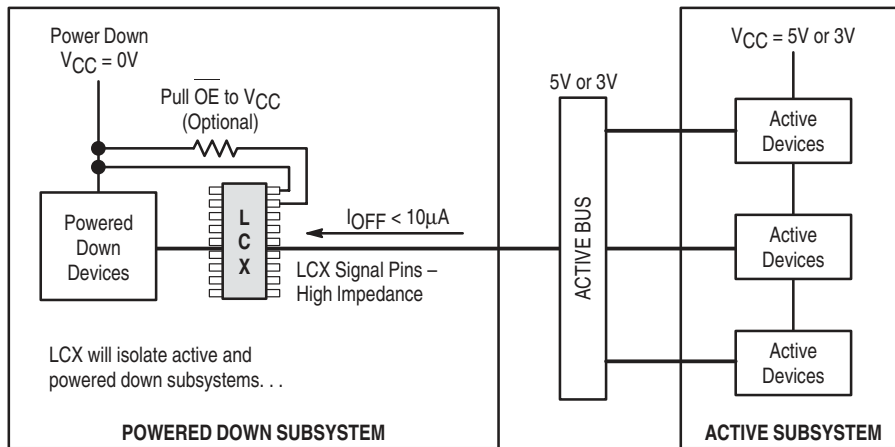

Figure 13. LCX Provides Power Management

# Design Considerations

The LCX family was designed to alleviate many of the drawbacks that are common to current low-voltage logic circuits. LCX combines the low static power consumption and the high noise margins of CMOS with a high fan-out, low input loading and a 50Ω transmission line drive capability.

Performance features such as 5ns speeds at CMOS power levels, ±24mA drive, excellent noise, ESD and latch-up immunity are characteristics that designers of state-of-the-art systems require. LCX provides this level of performance. To fully utilize the advantages provided by LCX, the system designer should have an understanding of the flexibility as well as the trade-offs of CMOS design. The following section discusses common design concerns relative to the performance and requirements of LCX.

There are six items of interest which need to be evaluated when implementing LCX devices in new designs:

- Thermal Management — circuit performance and long-term circuit reliability are affected by die temperature.
- Interfacing — interboard and technology interfaces, battery backup and power down or live insert/extract systems require some special thought.
- Transmission Line Driving — LCX has excellent line driving capabilities.
- Noise effects — As edge rates increase, the probability of crosstalk and ground bounce problems increases. The enhanced noise immunity and high threshold levels improve LCX's resistance to crosstalk problems.
- Board Layout — Prudent board layout will ensure that most noise effects are minimized.
- Power Supplies and Decoupling — Maximize ground and V<sub>CC</sub> traces to keep V<sub>CC</sub>/ground impedance as low as possible; full ground/V<sub>CC</sub> planes are best. Decouple any device driving a transmission line; otherwise add one capacitor for every package

## Thermal Management

Circuit performance and long-term circuit reliability are affected by die temperature. Normally, both are improved by keeping the IC junction temperatures low.

Electrical power dissipated in any integrated circuit is a source of heat. This heat source increases the temperature of the die relative to some reference point, normally the ambient temperature of 25°C in still air. The temperature increase, then, depends on the amount of power dissipated in the circuit and on the net thermal resistance between the heat source and the reference point. See the Thermal Management Considerations Section on page 283 for LCX power calculations.

The temperature at the junction is a function of the packaging and mounting system's ability to remove heat generated in the circuit — from the junction region to the ambient environment. The basic formula for converting power dissipation to estimated junction temperature is:

$$T_J = T_A + P_D(\bar{\theta}_{JC} + \bar{\theta}_{CA}) \quad (1)$$

$$\text{or} \quad T_J = T_A + P_D(\bar{\theta}_{JA}) \quad (2)$$

where

$T_J$  = maximum junction temperature  
 $T_A$  = maximum ambient temperature  
 $P_D$  = calculated maximum power dissipation including effects of external loads (see Power Dissipation in

— section III).

$\bar{\theta}_{JC}$  = average thermal resistance, junction to case

$\bar{\theta}_{CA}$  = average thermal resistance, case to ambient

$\bar{\theta}_{JA}$  = average thermal resistance, junction to ambient

This Motorola recommended formula has been approved by RADC and DESC for calculating a "practical" maximum operating junction temperature for MIL-M-38510 (JAN) devices.

Only two terms on the right side of equation (1) can be varied by the user — the ambient temperature, and the device case-to-ambient thermal resistance,  $\bar{\theta}_{CA}$ . (To some extent the device power dissipation can also be controlled, but under recommended use the V<sub>CC</sub> supply and loading dictate a fixed power dissipation.) Both system air flow and the package mounting technique affect the  $\bar{\theta}_{CA}$  thermal resistance term.  $\bar{\theta}_{JC}$  is essentially independent of air flow and external mounting method, but is sensitive to package material, die bonding method, and die area.

For applications where the case is held at essentially a fixed temperature by mounting on a large or temperature-controlled heat sink, the estimated junction temperature is calculated by:

$$T_J = T_C + P_D(\bar{\theta}_{JC}) \quad (3)$$

where  $T_C$  = maximum case temperature and the other parameters are as previously defined.

## Air Flow

The effect of air flow over the packages on  $\bar{\theta}_{JA}$  (due to a decrease in  $\bar{\theta}_{CA}$ ) reduces the temperature rise of the package, therefore permitting a corresponding increase in power dissipation without exceeding the maximum permissible operating junction temperature.

Even though different device types mounted on a printed circuit board may each have different power dissipations, all will have the same input and output levels provided that each is subject to identical air flow and the same ambient air temperature. This eases design, since the only change in levels between devices is due to the increase in ambient temperatures as the air passes over the devices, or differences in ambient temperature between two devices.

The majority of users employ some form of air-flow cooling. As air passes over each device on a printed circuit board, it absorbs heat from each package. This heat gradient from the first package to the last package is a function of the air flow rate and individual package dissipations.

## Optimizing The Long Term Reliability of Plastic Packages

Today's plastic integrated circuit packages are as reliable as ceramic packages under most environmental conditions. However when the ultimate in system reliability is required, thermal management must be considered as a prime system design goal.



## Design Considerations

Modern plastic package assembly technology utilizes gold wire bonded to aluminum bonding pads throughout the electronics industry. When exposed to high temperatures for protracted periods of time an intermetallic compound can form in the bond area resulting in high impedance contacts and degradation of device performance. Since the formation of intermetallic compounds is directly related to device junction temperature, it is incumbent on the designer to determine that the device junction temperatures are consistent with system reliability goals.

### Predicting Bond Failure Time

Based on the results of almost ten (10) years of +125°C operating life testing, a special arrhenius equation has been developed to show the relationship between junction temperature and reliability.

$$(1) T = (6.376 \times 10^{-9})e^{\left[ \frac{11554.267}{273.15 + T_J} \right]}$$

Where:  $T$  = Time in hours to 0.1% bond failure (1 failure per 1,000 bonds).

$T_J$  = Device junction temperature, °C.

And:

$$(2) T_J = T_A + P_D \Theta_{JA} = T_A + \Delta T_J$$

Where:  $T_J$  = Device junction temperature, °C.

$T_A$  = Ambient temperature, °C.

$P_D$  = Device power dissipation in watts.

$\Theta_{JA}$  = Device thermal resistance, junction to air, °C/Watt.

$\Delta T_J$  = Increase in junction temperature due to on-chip power dissipation.

Table 1 shows the relationship between junction temperature, and continuous operating time to 0.1% bond failure, (1 failure per 1,000 bonds).

**TABLE 1 — DEVICE JUNCTION TEMPERATURE versus TIME TO 0.1% BOND FAILURES.**

Junction Temperature °C	Time, Hours	Time, Years
80	1,032,200	117.8
90	419,300	47.9
100	178,700	20.4
110	79,600	9.4
120	37,000	4.2
130	17,800	2.0
140	8,900	1.0

Table 1 is graphically illustrated in Figure 14 which shows that the reliability for plastic and ceramic devices is the same until elevated junction temperatures induce intermetallic failures in plastic devices. Early and mid-life failure rates of plastic devices are not effected by this intermetallic mechanism.

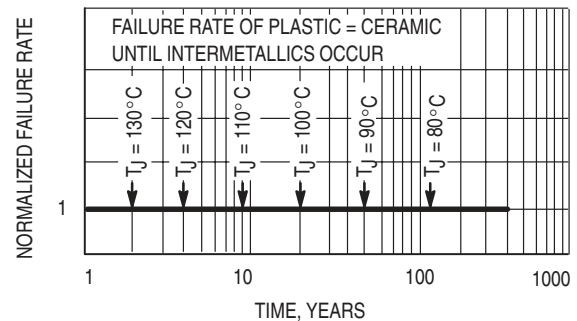

**Figure 14. Failure Rate versus Time Junction Temperature**

### Procedure

After the desired system failure rate has been established for failure mechanisms other than intermetallics, each device in the system should be evaluated for maximum junction temperature. Knowing the maximum junction temperature, refer to Table 1 or Equation 1 to determine the continuous operating time required to 0.1% bond failures due to intermetallic formation. At this time, system reliability departs from the desired value as indicated in Figure 14.

Air flow is one method of thermal management which should be considered for system longevity. Other commonly used methods include heat sinks for higher powered devices, refrigerated air flow and lower density board stuffing. Since  $\Theta_{CA}$  is entirely dependent on the application, it is the responsibility of the designer to determine its value. This can be achieved by various techniques including simulation, modeling, actual measurement, etc.

The material presented here emphasizes the need to consider thermal management as an integral part of system design and also the tools to determine if the management methods being considered are adequate to produce the desired system reliability.

## Line Driving

With the available high-speed logic families, designers can reach new heights in system performance. Yet, these faster devices require a closer look at transmission line effects.

Although all circuit conductors have transmission line properties, these characteristics become significant when the edge rates of the drivers are equal to or less than three times the propagation delay of the line. Significant transmission line properties may be exhibited in an example where devices have edge rates of 3ns and lines of 8 inches or greater, assuming propagation delays of 1.7 ns/ft for an unloaded printed circuit trace.

Of the many properties of transmission lines, two are of major interest to the system designer:  $Z_{oe}$ , the effective equivalent impedance of the line, and  $t_{pde}$ , the effective propagation delay down the line. It should be noted that the intrinsic values of line impedance and propagation delay,  $Z_o$  and  $t_{pd}$ , are geometry-dependent. Once the intrinsic values are known, the effects of gate loading can be calculated. The loaded values for  $Z_{oe}$  and  $t_{pde}$  can be calculated with:

$$Z_{oe} = \frac{Z_o}{\sqrt{1 + C_t/C_l}}$$

$$t_{pde} = t_{pd} \sqrt{1 + C_t/C_l}$$

where  $C_l$  = intrinsic line capacitance and  $C_t$  = additional capacitance due to gate loading.

The formulas indicate that the loading of lines decreases the effective impedance of the line and increases the propagation delay. Lines that have a propagation delay greater than one third the rise time of the signal driver should be evaluated for transmission line effects. When performing transmission line analysis on a bus, only the longest, most heavily loaded and the shortest, least loaded lines need to be analyzed. All lines in a bus should be terminated equally; if one line requires termination, all lines in the bus should be terminated. This will ensure similar signals on all of the lines.

There are several termination schemes which may be used. Included are series, parallel, AC parallel and Thevenin terminations. AC parallel and series terminations are the most useful for low power applications since they do not consume any DC power. Parallel and Thevenin terminations experience high DC power consumption.

## Termination Schemes

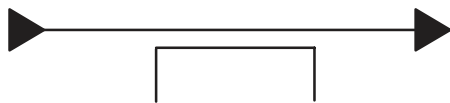

a: No Termination

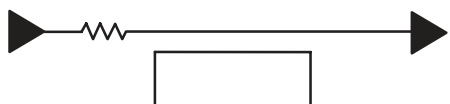

b: Series Termination

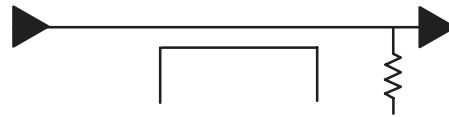

c: Parallel Termination

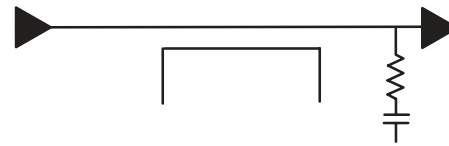

d: AC Parallel Termination

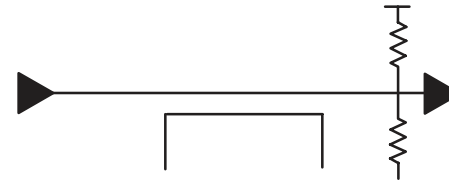

e: Thevenin Termination

Figure 15. Termination Schemes

## Series Terminations

Series terminations are most useful in high-speed applications where most of the loads are at the far end of the line. Loads that are between the driver and the end of the line will receive a two-step waveform. The first wave will be the incident wave. The amplitude is dependent upon the output impedance of the driver, the value of the series resistor and the impedance of the line according to the formula

$$V_W = V_{CC} \cdot Z_{oe}/(Z_{oe} + R_S + Z_S)$$

The amplitude will be one-half the voltage swing if  $R_S$  (the series resistor) plus the output impedance ( $Z_S$ ) of the driver is equal to the line impedance. The second step of the waveform is the reflection from the end of the line and will have an amplitude equal to that of the first step. All devices on the line will receive a valid level only after the wave has propagated down the line and returned to the driver. Therefore, all inputs will see the full voltage swing within two times the delay of the line.

## Parallel Termination

Parallel terminations are not generally recommended for CMOS circuits due to their power consumption, which can exceed the power consumption of the logic itself. The power consumption of parallel terminations is a function of the resistor value and the duty cycle of the signal. In addition, parallel termination tends to bias the output levels of the driver towards either  $V_{CC}$  or ground. While this feature is not desirable for driving CMOS inputs, it can be useful for driving TTL inputs.

## AC Parallel Termination

AC parallel terminations work well for applications where the delays caused by series terminations are unacceptable. The effects of AC parallel terminations are similar to the effects of standard parallel terminations. The major difference is that the capacitor blocks any DC current path and helps to reduce power consumption.



## Design Considerations

### Thevenin Termination

Thevenin terminations are also not generally recommended due to their power consumption. Like parallel termination, a DC path to ground is created by the terminating resistors. The power consumption of a Thevenin termination will generally not be a function of the signal duty cycle. Thevenin terminations are more applicable for driving CMOS inputs because they do not bias the output levels as paralleled terminations do. It should be noted that lines with Thevenin terminations should not be left floating since this will cause the input levels to float between  $V_{CC}$  or ground, increasing power consumption.

LCX circuits have been designed to drive  $50\Omega$  transmission lines over the full temperature range.

LCX devices also feature balanced totem pole output structures to allow equal source and sink current capability. This provides balanced edge rates and equal rise and fall times. Balanced drive capability and transition times eliminates the need to calculate two different delay times for each signal path and the requirement to correct signal polarity for the shortest delay time.

### Noise Effects

LCX offers excellent noise immunity. However, even the most advanced technology alone cannot eliminate noise problems. Good circuit board layout techniques are essential to take full advantage of the superior performance of LCX circuits.

Well-designed circuit boards also help eliminate manufacturing and testing problems.

Another recommended practice is to segment the board into a high-speed area, a medium-speed area and a low-speed area. The circuit areas with high current requirements (i.e., buffer circuits and high-speed logic) should be as close to the power supplies as possible; low-speed circuit areas can be furthest away.

Decoupling capacitors should be adjacent to all buffer chips; they should be distributed throughout the logic: one capacitor per chip. Transmission lines need to be terminated to keep reflections minimal. To minimize crosstalk, long signal lines should not be close together.

### Crosstalk

The problem of crosstalk and how to deal with it is becoming more important as system performance and board densities increase. Crosstalk is the capacitive coupling of signals from one line to another. The amplitude of the noise generated on the inactive line is directly related to the edge rates of the signal on the active line, the proximity of the two lines and the distance that the two lines are adjacent.

Crosstalk has two basic causes. Forward crosstalk, Figure 16, is caused by the wavefront propagating down the printed circuit trace at two different velocities. This difference in velocities is due to the difference in the dielectric constants of air ( $\epsilon_r = 1$ ) and epoxy glass ( $\epsilon_r = 4.7$ ). As the wave propagates down the trace, this difference in velocities will cause one edge to reach the end before the other. This delay is the cause of forward crosstalk; it increases with longer trace length, so consequently the magnitude of forward crosstalk will increase with distance.

Reverse crosstalk, Figure 17, is caused by the mutual inductance and capacitance between the lines which is a

transformer action. Reverse crosstalk increases linearly with distance up to a critical length. This critical length is the distance that the signal can travel during its rise or fall time.

Although crosstalk cannot be totally eliminated, there are some design techniques that can reduce system problems resulting from crosstalk. LCX's industry-leading noise margins makes it easier to design systems immune to crosstalk-related problems.

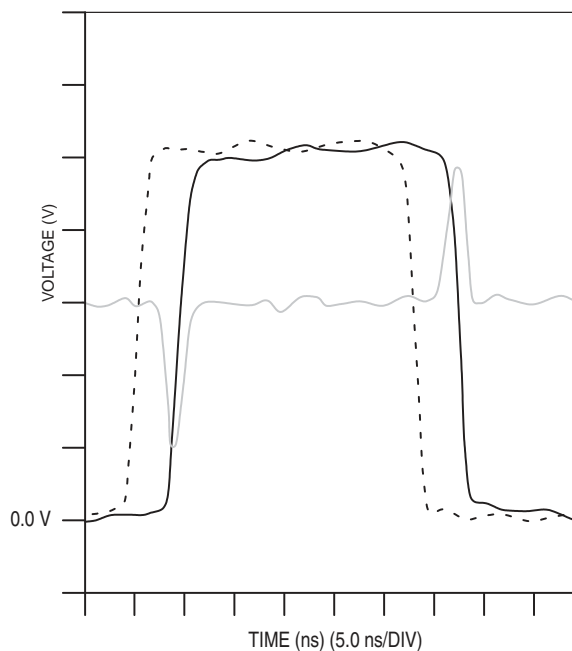

Figure 16. Forward Crosstalk on PCB Traces

Key	Vertical Scale	Horizontal Scale
- - - - Active Driver	1.0 V/Div	50 ns/Div
— Forward Crosstalk	0.2 V/Div	5.0 ns/Div
— Active Receiver	1.0 V/Div	5.0 ns/Div

This figure shows traces taken on a test fixture designed to exaggerate the amplitude of crosstalk pulses.

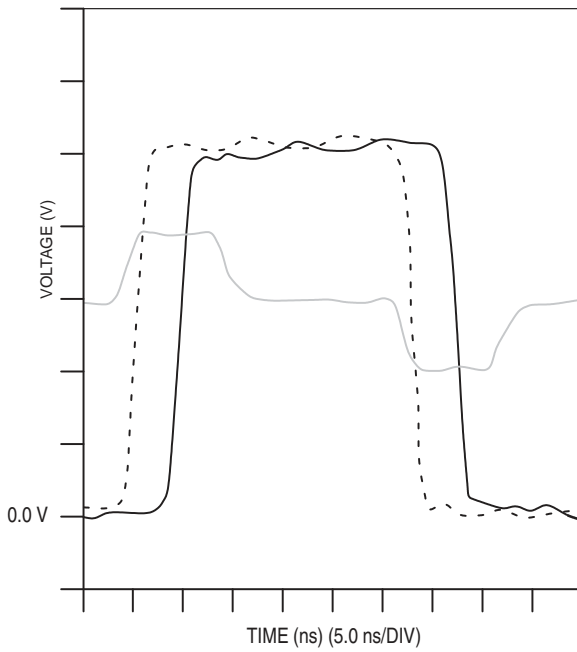

Figure 17. Reverse Crosstalk on PCB Traces

Key	Vertical Scale	Horizontal Scale
----- Active Driver	1.0 V/Div	50 ns/Div
—— Forward Crosstalk	0.2 V/Div	5.0 ns/Div
—— Active Receiver	1.0 V/Div	5.0 ns/Div

This figure shows traces taken on a test fixture designed to exaggerate the amplitude of crosstalk pulses.

### Ground Bounce

Ground bounce occurs as a result of the intrinsic characteristics of the leadframes and bondwires of the packages used to house CMOS devices. As edge rates and drive capability increase in advanced logic families, the effects of these intrinsic electrical characteristics become more pronounced.

Figure 18 shows a simple circuit model for a device in a leadframe driving a standard test load. The inductor L1 represents the parasitic inductance in the ground lead of the package; inductor L2 represents the parasitic inductance in the power lead of the package; inductor L3 represents the parasitic inductance in the output lead of the package; the resistor R1 represents the output impedance of the device output, and the capacitor and resistor C<sub>L</sub> and R<sub>L</sub> represent the standard test load on the output of the device.

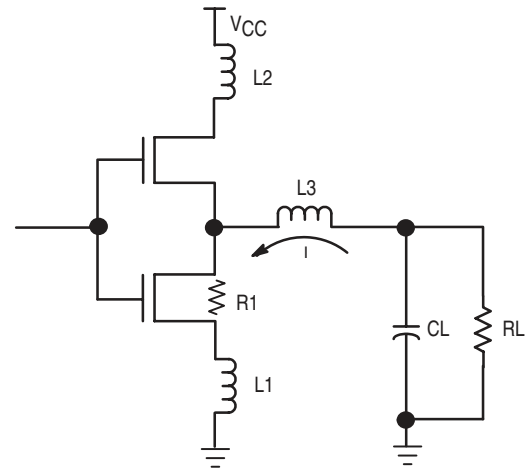

Figure 18. Output Model

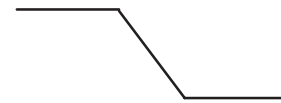

Figure 19. Output Voltage



Figure 20. Output Current

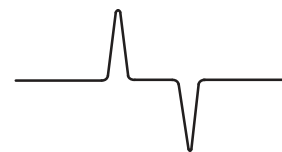

Figure 21. Inductor Voltage

## Design Considerations

The three waveforms shown in Figure 19 through Figure 21 depict how ground bounce is generated. The first waveform shows the voltage (V) across the load as it is switched from a logic HIGH to a logic LOW. The output slew rate is dependent upon the characteristics of the output transistor, the inductors L1 and L3, and  $C_L$ , the load capacitance. The second waveform shows the current that is generated as the capacitor discharges [ $I = C_L \cdot dV/dt$ ]. The third waveform shows the voltage that is induced across the inductance in the ground lead due to the changing currents [ $V_{gb} = -L \cdot (dI/dt)$ ].

There are many factors which affect the amplitude of the ground bounce. Included are:

- Number of outputs switching simultaneously: more outputs result in more ground bounce.
- Type of output load: capacitive loads generate two to three times more ground bounce than typical system traces. Increasing the capacitive load to approximately 60–70 pF increases ground bounce. Beyond 70 pF, ground bounce drops off due to the filtering effect of the load. Moving the load away from the output reduces the ground bounce.
- Location of the output pin: outputs closer to the ground pin exhibit less ground bounce than those further away.
- Voltage: lowering  $V_{CC}$  reduces ground bounce.
- Test fixtures: standard test fixtures generate 30 to 50% more ground bounce than a typical system since they use capacitive loads which both increase the AC load and form LCR tank circuits that oscillate.

Ground bounce produces several symptoms:

- Altered device states. LCX does not exhibit this symptom.
- Propagation delay degradation. LCX devices are characterized not to degrade more than 200ps per additional output switching.
- Undershoot on active outputs. The worst-case undershoot will be approximately equal to the worst-case quiet output noise.
- Quiet output noise. The LCX worst case quiet output has been characterized to be typically 800mV. It will be much less in well designed systems.

Observing either one of the following rules is sufficient to avoid running into any of the problems associated with ground bounce:

- First, use caution when driving asynchronous TTL-level inputs from CMOS octal outputs, or
- Second, use caution when running control lines (set, reset, load, clock, chip select) which are glitch-sensitive through the same devices that drive data or address lines.

When it is not possible to avoid the above conditions, there are simple precautions available which can minimize ground bounce noise. These are:

- Locate these outputs as close to the ground pin as possible.
- Use the lowest  $V_{CC}$  possible or separate the power supplies.
- Use board design practices which reduce any additive noise sources, such as crosstalk, reflections, etc.

## Design Rules

The set of design rules listed below are recommended to ensure reliable system operation by providing the optimum power supply connection to the devices. Most designers will recognize these guidelines as those they have employed with advanced bipolar logic families.

- Use multi-layer boards with  $V_{CC}$  and ground planes, with the device power pins soldered directly to the planes to ensure the lowest power line impedances possible.
- Use decoupling capacitors for every device, usually 0.1  $\mu\text{F}$  should be adequate. These capacitors should be located as close to the ground pin as possible.
- Do not use sockets or wirewrap boards whenever possible.
- Do not connect capacitors from the outputs directly to ground.

## Decoupling Requirements

Motorola's LCX family, as with other high-performance, high-drive logic families, has special decoupling and printed circuit board layout requirements. Adhering to these requirements will ensure the maximum advantages are gained with LCX products.

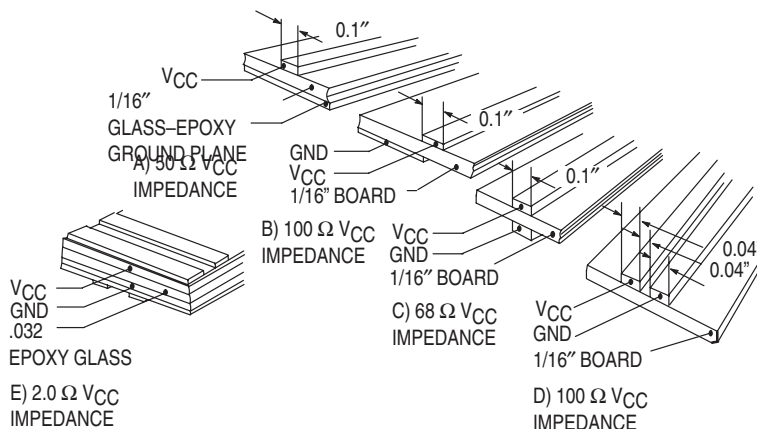

Figure 22. Power Distribution Impedances

Local high frequency decoupling is required to supply power to the chip when it is transitioning from a LOW to a HIGH value. This power is necessary to charge the load capacitance or drive a line impedance. Figure 22 displays various  $V_{CC}$  and ground layout schemes along with associated impedances.

For most power distribution networks, the typical impedance is between 100 and 150Ω. This impedance appears in series with the load impedance and will cause a droop in the  $V_{CC}$  at

the part. This limits the available voltage swing at the local node, unless some form of decoupling is used. This drooping of rails will cause the rise and fall times to become elongated. Consider the example described in Figure 23 to calculate the amount of decoupling necessary. This circuit utilizes an LCX240 driving a 150Ω bus from a point somewhere in the middle.

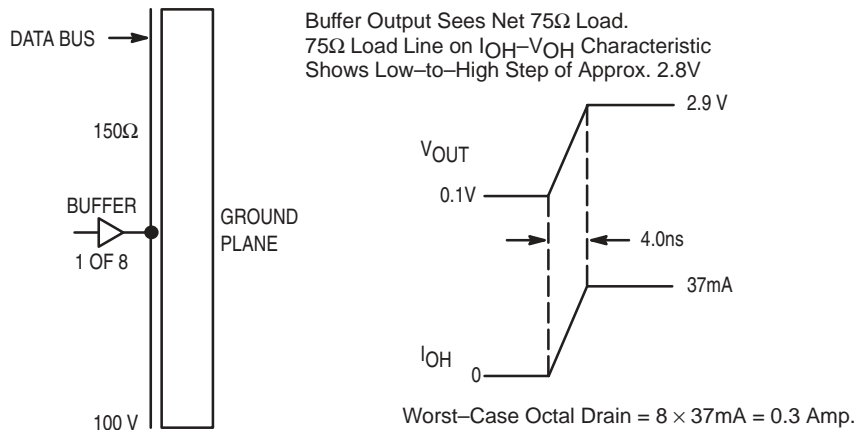

Figure 23. Octal Buffer Driving a 150Ω Bus

Being in the middle of the bus, the driver will see two 150Ω loads in parallel, or an effective impedance of 75Ω. To switch the line from rail to rail, a drive of 37mA is needed; about 300mA will be required if all eight lines switch at once. This instantaneous current requirement will generate a voltage across the impedance of the power lines, causing the actual  $V_{CC}$  at the chip to droop. This droop limits the voltage swing available to the driver. The net effect of the voltage droop will lengthen device rise and fall times and slow system operation. A local decoupling capacitor is required to act as a low impedance supply for the driver chip during high current conditions. It will maintain the voltage within acceptable limits and keep rise and fall times to a minimum. The necessary values for decoupling capacitors can be calculated with the formula given in Figure 24.

In this example, if the  $V_{CC}$  droop is to be kept below 30mV and the edge rate equals 4 ns, a 0.04μF capacitor is needed.

It is good practice to distribute decoupling capacitors evenly through the logic, placing one capacitor for every package.

### Capacitor Types

Decoupling capacitors need to be of the high K ceramic type with low equivalent series resistance (ESR), consisting primarily of series inductance and series resistance. Capacitors using 5ZU dielectric have suitable properties and make a good choice for decoupling capacitors; they offer minimum cost and effective performance.

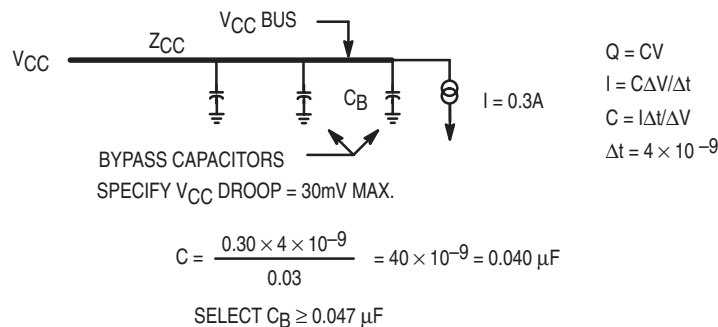

Place one decoupling capacitor adjacent to each package driving any transmission line and distribute others evenly throughout the logic.

Figure 24. Formula for Calculating Decoupling Capacitors

## Reliability Information

### Motorola Reliability and Quality Assurance

Motorola has a long standing reputation for manufacturing products of excellent Quality and Reliability since the introduction of the first car radio in 1928. This has helped Motorola to become one of the largest corporations exclusively devoted to electronics.

In today's semiconductor marketplace, two important elements for the success of a company are its quality and reliability systems. They are interrelated, reliability being quality extended over the expected life of a product. For any manufacturer to remain in business, its products must meet or exceed basic quality and reliability standards and customer needs.

At Motorola, the most stringent and demanding definitions of quality and reliability are used.

#### *Quality*

- Reduction of variability around a target so that conformance to customer requirements and expectations can be achieved in a cost-effective way
- The probability that a device (equipment, parts) will have performance characteristics within specified limits
- Fitness for use

#### *Reliability*

- Quality in time and environment
- The probability that our semiconductor devices, which initially have satisfactory performance, will continue to perform their intended function for a given time in usage environments

At Motorola, our Reliability and Quality Assurance Program is designed to generate ongoing data for both reliability and quality for the various product families. Both reliability and quality monitors are performed on the different major categories of semiconductor products. These monitors are designed to test the product's design and material as well as to identify and eliminate potential failure mechanisms to ensure reliable device performance in a "real world" application. Thus, the primary purpose of the program is to identify trends from generated data, so if need be, corrective action(s) can be taken toward improving performance. In addition, this reliability and quality data can be utilized by our customers for failure rate predictions.

It is the explicit purpose of this communication to inform the customer of our LCX qualification results. In addition, we have provided a general definition of our reliability and quality assurance program.

## LCX Device Description

Motorola's LCX family, the first Low-Voltage CMOS family with 5V tolerant inputs and outputs, is manufactured on the H4C "plus" 75% CMOS (double layer metal) process at MOS 6. The LCX family emphasizes low power, low switching noise, and fast switching speeds. LCX devices will be assembled in SOIC, SSOP and TSSOP packages. The H4C "plus" 75% CMOS process in MOS 6 was qualified using the LCX family's E76S maskset.

## LCX Processing Information

### PROCESSING SUMMARY — H4C "plus," 75% CMOS (Double Layer Metal)

#### General

Process Type	CMOS on EPI
Effective Channel Length	Min. target=0.65 $\mu$ m
Process Complexity	Single Poly, Double Metal

#### Gate Processing

Gate Oxide Thickness	150Å
Gate Terminal	Phosphorous Doped Polysilicon (POCL)
N+ Source Drain Dopant	Phosphorous & Arsenic
P+ Source Drain Dopant	Boron (BF <sub>2</sub> )

#### Metallization Processing

Metal Composition	AlSiCu w/TiN Barrier (M1) AlSiCu (M2)
-------------------	--

#### Passivation Processing

Passivation Type	Double Layer, Nitride over PSG Oxide
------------------	--------------------------------------

#### Electrical Characteristics

Field Threshold Voltage	>12V
Punchthrough Voltage	>12V
Gate Oxide Breakdown	>14V



# LCX Qualification Introduction

*LCX Qualification consisted of intrinsic and extrinsic reliability testing. Intrinsic reliability concerns device degradation issues and is assessed via electromigration, hot carrier injection and dielectric breakdown measures. Extrinsic reliability addresses both processing and packaging related issues and utilizes several tests: high temperature bias, temperature cycling, pressure temperature humidity, thermal shock, temperature humidity bias, surface mount preconditioning, physical dimensions, solderability and marking permanency. (Included below are definitions of the aforementioned terms.)*

## INTRINSIC RELIABILITY

### Electromigration

Electromigration is the movement of metal in the direction of electron flow. This is accelerated by high current densities and temperatures which result in metal void and/or collection (hillock) formations, and ultimately shorts. Design rules specify minimum metal widths and maximum current densities to circumvent electromigration issues.

### Hot Carrier Injection (HCI)

Hot carrier injection is the result of electron scattering and subsequent trapping in the gate oxide of MOS devices. Scattering is a function of electron velocity and thus electric fields and temperature. Ultimately, carrier mobility and transconductance are reduced causing threshold voltage shifts. Processing conditions are set to minimize hot carrier generation rates and gate trapping efficiencies.

### Dielectric Breakdown

Dielectric breakdown results in the formation of a conductive path connecting once-isolated conducting layers. High voltage induced charge injection and trapping accelerates this breakdown. Dielectric integrity is maximized via uniform depositional thickness, and dielectric quality is achieved through minimizing impurity, charge, and defect levels.

## EXTRINSIC RELIABILITY

### High Temperature Bias (HTB)

High temperature bias (HTB) testing is performed to accelerate failure mechanisms which are activated through the application of elevated temperatures and the use of biased operating conditions. The temperature and voltage conditions used in the stress are dependent on the product under stress. However, the typical ambient temperature is 145°C with the static bias applied equal to or greater than the data sheet nominal value.

### Temperature Cycling (MIL-STD-883D-1010C)

Temperature cycle testing accelerates the effects of thermal expansion mismatch among the different components within a specific die and packaging system. This test is typically performed per MIL-STD-883D Method 1010C with the minimum and maximum temperatures being -65°C and +150°C, respectively. During temperature cycle testing, devices are inserted into a cycling system and held at the cold dwell temperature for at least ten minutes. Following this cold dwell, the devices are heated to the hot dwell where they remain for another ten minute minimum time period. The system employs a circulating air environment to assure rapid stabilization at the specified temperature. The dwell at each extreme, plus the two transition times of five minutes each (one up to the hot dwell temperature, another down to the cold dwell temperature), constitute one cycle.

### Thermal Shock (MIL-STD-883D-1010C)

The objective of thermal shock testing is the same as that for temperature cycle testing, that is, to emphasize differences in expansion coefficients for components of the packaging system. However, thermal shock provides additional stress, in that the device is exposed to a sudden change in temperature due to a maximum transfer time of ten seconds, as well as the increased thermal conductivity of a liquid ambient. This test is typically performed per MIL-STD-883D Method 1011C with minimum and maximum temperatures being -65 °C to +150 °C, respectively. Devices are placed in a bath and cooled to minimum specified temperature. After being held in the cold chamber for five minutes minimum, the devices are transferred to an adjacent chamber at the maximum specified temperature for an equivalent time. Two five minute dwells plus two ten second transitions constitute one cycle.

### Temperature Humidity Bias (THB Motorola Std)

This stress is performed to accelerate the effects of moisture penetration, with the dominant effect being corrosion. Conditions employed during this test are a temperature of 85°C, humidity of 85% RH, and a nominal bias level.

### Pressure Temperature Humidity (PTH Motorola Std)

This stress is performed to accelerate the effects of moisture penetration, with the dominant effect being corrosion. This test detects similar failure mechanisms as THB but at a greatly accelerated rate. Conditions employed during this test are a temperature of 121°C, pressure of 15psig or greater, humidity of 100% RH, unbiased.

### Surface Mount Preconditioning (Motorola Std)

Preconditioning tests are performed to simulate the customer board mount process where surface mount parts are subjected to a high temperature for a short duration. These tests detect mold compound delamination from the die and leadframe which can result in reliability failures. The dominant failure mechanism is corrosion, but other

## Reliability Information

stress-related problems could also occur like fractured wirebonds, passivation cracks, smeared metal on die, etc.

The conditions typically used are 245°C for IR reflow and 260°C for solder immersion. For small pitch packages, a 260°C oil immersion is substituted for the 260°C solder to avoid solder bridging of the leads.

### **Physical Dimensions (MIL-STD-883D-2016)**

The purpose of this test is to verify the external dimensions of the device are in accordance with the case outline specification. This test is typically performed per MIL-STD-883D Method 2016.

### **Solderability (MIL-STD-883D-2003)**

The purpose of this test is to determine the solderability of all terminations which are normally joined by a soldering

operation. This test is typically performed per MIL-STD-883D Method 2003. The test verifies the ability of these terminations to be wetted or coated by solder, and to predict suitable fillet when dip soldered. An accelerated aging test is included in this method which simulates a minimum of six months natural aging under a combination of various storage conditions that have a deleterious effect on the solderability.

### **Marking Permanency (Motorola Std)**

The purpose of this test is to verify the device markings will not become illegible when subjected to solvents, and the solvents will not cause any mechanical, electrical, damage or deterioration, of the materials or finishes. This test is typically performed per Motorola standard.



## Process Qualification Information

### PROCESS QUALIFICATION SUMMARY

The H4C “plus” 75% CMOS (double layer metal) process qualification consisted of intrinsic reliability testing (Electromigration, Hot Carrier Injection, and Dielectric Breakdown) and extrinsic reliability testing (High Temperature Bias, Temperature Cycling, and Pressure Temperature Humidity).

The intrinsic reliability measures indicate no significant degradation over the lifetime of the device. Extrinsic reliability for the process resulted in zero failures.

### INTRINSIC RELIABILITY RESULTS

#### DEVICE QUALIFICATION

##### Electromigration

Electromigration evaluation of MOS 6 metals used in the H4C “plus” 75% CMOS (double layer metal) process revealed an acceptable metallization process for a minimum lifetime of 10 years at 100°C with  $\leq .01\%$  cumulative failures.

##### Hot Carrier Injection

HCI test (low temperature electrical stress) results indicate less than 10% change in transconductance over the lifetime of the transistor.

##### Dielectric Breakdown

The current conduction and QBD (charge breakdown) data taken in MOS 6 was used to calculate an intrinsic gate oxide lifetime of 1364 years. This estimated lifetime greatly exceeds the expected lifetime of the device.

### EXTRINSIC RELIABILITY RESULTS/DATA

#### PROCESS QUALIFICATION

The reliability testing consisted of High Temperature Bias (145°C, 3.6V bias), Temperature Cycling (–65°C to 150°C), and PTH (121°C, 15PSIG, & 100% RH). Samples from three wafer lots were tested.

One wafer lot was a metal/dielectric split lot. The metal and dielectric layers were run at the maximum and minimum thickness specifications in order to account for step coverage extremes.

The second wafer lot was a  $V_t$ /Leff split lot. The  $V_t$  and Leff were run at minimum and maximum specifications in order to account for extremes in leakage, speed, and translation window.

The remaining lot was a nominal lot. Zero process related rejects occurred after 504 hours of op–life, 600 temp cycles, and 240 hours of PTH. (The device failure in time (FIT) was calculated based on HTB results at 14.4; stress temp = 145°C; activation energy = 0.7eV).

The H4C “plus” 75% CMOS (double layer metal) process in MOS 6 was qualified and approved in light of the results of the above intrinsic and extrinsic reliability results.

## Package Qualification

MC74LCX family is being offered in SOIC, SSOP and TSSOP packaging. As the TSSOP package is a newer technology, a qualification summary has been included in this report. All reliability tests have passed successfully, including preconditioning tests used to simulate customer board mount processes (see below). Furthermore, based on reliability results, drypack\* is not required for this package type.

### Package Qualification Summary

TSSOP leads	Op Life	Temperature Cycle	HAST	Surface Mount Preconditioning	Solderability	Marking Permanency	Physical Dimension
14	PASS	PASS	PASS	PASS	PASS	PASS	PASS
16	PASS	PASS	PASS	PASS	PASS	PASS	PASS
20	PASS	PASS	PASS	PASS	PASS	PASS	PASS
24	PASS	PASS	PASS	PASS	PASS	PASS	PASS
48	PASS	PASS	PASS	PASS*	PASS	PASS	PASS
56	PASS	PASS	PASS	PASS*	PASS	PASS	PASS

\* 48 and 56 lead TSSOP packages are moisture class level 2 and require drypack. Moisture class level 1 qualification is in progress – upon successful completion, the 48–lead and 56–lead packages will no longer require dry pack.

## Summary Package Information

- Package Materials
  - 14, 16 and 20 Lead Hitachi CEL 9200N
  - 24 Lead Shinetsu KMC 184
  - 48, 56 Lead Sumitomo 7351T
- Leadframe Material Copper
- Plating 80/20 tin/lead solder plate
- Die Attach Epoxy
  - 14, 16 and 20 Lead Sumitomo CRM 1033B
  - 24 Lead Ablestik 84–1 LMISR4
  - 48, 56 Lead Ablestik 8361J
- Wire Bond Material 1.0 mil gold
- Wire Bond Method Thermosonic Ball
- 14–/16–Lead Flag Size 83 x 93 mils
- 20–Lead Flag Size 83 x 120 and 110 x 120 mils
- 24–Lead Flag Size 118 x 138 mils
- 48–Lead Flag Size 118 x 197 mils
- 56–Lead Flag Size 137 x 177 mils

## Reliability Audit Program Summary

*The Motorola Logic Reliability Audit Program (RAP) is designed to monitor the ability of Logic products to exceed minimum acceptable reliability standards. Mesa Reliability Engineering has overall responsibility for RAP, including updating requirements, interpreting results, offshore administration, and monthly reporting.*

### Testing

RAP is a system of mechanical, environmental, and electrical tests performed periodically on randomly selected samples of standard products. Each sample receives minimum standard tests covering all wafer fab sites, assembly sites, and packages. Within each family, devices are chosen to represent the range of die sizes and functional complexity.

In addition to standard tests, each package type also receives special pre-conditioning tests, the frequency of which is intended to sample every package type and assembly site once per month.

Reliability tests are run at three sites: Mesa, Arizona (LICD); Manila, Philippines (MPI); and Taipei, Taiwan (METL). Following mechanical and electrical testing, devices receive standard static and functional electrical tests using conditions and limits per applicable device specifications.

### Failures

All failed devices require recorded data. Failure data and failure verification information accompany all rejects to a product analysis lab where root cause failure analysis is performed on all occurrences observed at that site. All information regarding failed units is logged into a tracking database.

A review is called if any sample has a failure. The findings are analyzed relative to past performance to determine if customers are at risk for abnormally high failure rates. Customer notification may then be required and, if needed, is prepared and distributed. Following the completion of testing and data review, the local reliability engineering group enters all data into the Reliability Audit Program Database.

## Thermal Considerations

Prepared by: Lance K. Packer  
LCX Application Engineering

### Reliability of Plastic Packages

Although today's plastic packages are as reliable as ceramic packages under most environmental conditions, as the junction temperature increases a failure mode unique to plastic packages becomes a significant factor in the long term reliability of the device.

Modern plastic package assembly utilizes gold wire bonded to aluminum bonding pads throughout the electronics industry. As the temperature of the silicon (junction temperature) increases, an intermetallic compound forms between the gold and aluminum interface. This intermetallic formation results in a significant increase in the impedance of the wire bond and can lead to performance failure of the affected pin. With this relationship between intermetallic formation and junction temperature established, it is incumbent on the designer to ensure that the junction temperature for which a device will operate is consistent with the long term reliability goals of the system.

Reliability studies were performed at elevated ambient temperatures (125°C) from which an Arrhenius Equation (Eq 1), relating junction temperature to bond failure, was established. The application of this equation yields the values in 1. . This table relates the junction temperature of a device in a plastic package to the continuous operating time before 0.1% bond failure (1 failure per 1000 bonds).

$$T = 6.376 \times 10^{-9} e^{\left[ \frac{11554.267}{273.15 + T_J} \right]} \quad (\text{Eq 1})$$

Where:

T = Time to 0.1% bond failure

#### 1. . T<sub>j</sub> vs Time to 0.1% Bond Failure

Junction Temp. (°C)	Time (hours)	Time (yrs.)
80	1,032,200	117.8
90	419,300	47.9
100	178,700	20.4
110	79,600	9.1
120	37,000	4.2
130	17,800	2.0
140	8,900	1.0

### Thermal Management

As in any system, proper thermal management is essential to establish the appropriate trade-off between performance, density, reliability and cost. In particular, the designer should be aware of the reliability implication of continuously operating semiconductor devices at high junction temperatures.

The increasing popularity of surface mount devices (SMD) is putting a greater emphasis on the need for better thermal management of a system. This is due to the fact that SMD

packages generally require less board space than their through hole counterparts so that designs incorporating SMD technologies have a higher thermal density. To optimize the thermal management of a system it is imperative that the user understand all of the variables which contribute to the junction temperature of the device.

The variables involved in determining the junction temperature of a device are both supplier and user defined. The supplier, through lead frame design, mold compounds, die size and die attach, can positively impact the thermal resistance and the junction temperature of a device. Motorola continually experiments with new package designs and assembly techniques in an attempt to further enhance the thermal performance of its products.

It can be argued that the user has the greatest control of the variables which commonly impact the thermal performance of a device. Depending on the environment in which an IC is placed, the user could control over 75% of the current that flows through the device. Ambient temperature, air flow and related cooling techniques are the obvious user controlled variables, however, PCB substrate material, layout density, size of the air-gap between the board and the package, amount of exposed copper interconnect, use of thermally-conductive epoxies and number of boards in a box and output loading can all have significant impacts on the thermal performance of a system.

PCB substrates all have different thermal characteristics, these characteristics should be considered when exploring the PCB alternatives. The user should also account for the different power dissipations of the different devices in his system and space them on the PCB accordingly. In this way, the heat load is spread across a larger area and "hot spots" do not appear in the layout. Copper interconnect traces act as heat radiators, therefore, significant thermal dissipation can be achieved through the addition of interconnect traces on the top layer of the board. Finally, the use of thermally conductive epoxies can accelerate the transfer of heat from the device to the PCB where it can more easily be passed to the ambient.

The advent of SMD packaging and the industry push towards smaller, denser designs makes it incumbent on the designer to provide for the removal of thermal energy from the system. Users should be aware that they control many of the variables which impact the junction temperatures and, thus, to some extent, the long term reliability of their designs.

### Calculating Junction Temperature

The following equation can be used to estimate the junction temperature of a device in a given environment:

$$T_J = T_A + P_D \Theta_{JA}$$

where:

T<sub>J</sub> = Junction Temperature

T<sub>A</sub> = Ambient Temperature

P<sub>D</sub> = Power Dissipation

Θ<sub>JA</sub> = Avg Pkg Thermal Resistance (Junction Ambient)

$$\begin{aligned}
 P_D = & V_{CC} \left[ C_P V_{CC} \sum_{i=1}^s F_{OUT_i} \right] + V_{CC} [\Delta I_{CC}^n] \\
 & + (V_{CC} - V_{OH}) \left[ (V_{OH} - V_{OL}) \sum_{i=1}^s C_{L_i} F_{OUT_i} + \sum_{i=1}^h \frac{V_{OH}}{R_{D_i}} \right] \\
 & + (V_{OL}) \left[ (V_{OH} - V_{OL}) \sum_{i=1}^s C_{L_i} F_{OUT_i} + \sum_{i=1}^l \frac{(V_{CC} - V_{OL})}{R_{U_i}} \right]
 \end{aligned}$$

**Power Dissipation Equation**

The power dissipation equation is made up of five major factors controlled by the user which contribute to increased power dissipation:

- 1 Frequency of operation (output switching frequency)
- 2 Input voltage levels
- 3 Output loading (capacitive and resistive)
- 4  $V_{CC}$  level
- 5 Duty cycle

Each of these five factors are addressed in the estimating equation except duty cycle. Duty cycle can be addressed by “weighting” the power dissipation equation terms appropriately.

The first current term is  $I_{CCD}$ , with the device unloaded. It is caused by the internal switching of the device. Static  $I_{CC}$  is so small for LCX, that when estimating power dissipation, it is ignored.

$$C_P V_{CC} \sum_{i=1}^s F_{out_i}$$

This term represents the  $I_{CC}$  current with absolutely no load. This measurement is taken without the output pins connected to the board. The  $C_P$  for a device is calculated by:

$$C_P = \frac{I_{CC}(@50MHz) - I_{CC}(@1MHz)}{V_{CC}(49MHz)s}$$

“s” is the number of outputs switching.  $C_P$  may vary slightly from part to part within a product family.

The next term is from current due to holding the CMOS inputs at  $V_{CC}-0.6V$  rather than at the rail voltages. This term becomes insignificant as load and frequency increase.

$$\Delta I_{CC}^n$$

$\Delta I_{CC}$  is the through current when holding the input High of a device to  $V_{CC}-0.6V$ . This value is typically 300 $\mu$ A or less. “n” is the number of inputs held at this level.

The third term is current through the upper structure of the device. It is caused by the external capacitive load and the output frequency. If a capacitive load exists then this term can become very significant.

$$(V_{OH} - V_{OL}) \sum_{i=1}^s C_{L_i} F_{OUT_i}$$

$V_{OH}-V_{OL}$  is the voltage swing of the output.  $C_L$  is the output load (this could vary from output to output).  $F_{OUT}$  is the output frequency which can also vary from output to output.

The fourth term stems from current through the upper structure due to an external resistive load to ground.

As the output frequency increases, the measured current approaches that of static High outputs.

$$\sum_{i=1}^h \frac{V_{OH}}{R_{D_i}}$$

$R_D$  is an external pull-down resistor. A different value load could be applied to each output.

The fifth current term is determined by the output capacitive load and the output frequency on the lower structure of the device. If this load exists than this term is also significant.

$$(V_{OH} - V_{OL}) \sum_{i=1}^s C_{L_i} F_{OUT_i}$$

All variables are the same as with the third term with the exception that this is current flowing through the lower structure of the IC. This current is not  $I_{CC}$ , but rather current that is “sunked” from an external source.

The final term is due to an external load connected to  $V_{CC}$ . This term includes both switching and static Low outputs.

$$\sum_{i=1}^l \frac{(V_{CC} - V_{OL})}{R_{U_i}}$$

As with term five, this is current that flows through the lower structure of the IC. This current too is not  $I_{CC}$ .

### Example of Thermal Calculations

Junction temperature can be estimated using the following equation:

$$T_J = (\theta_{JA} \times P_D) + T_A$$

where:

- $T_J$  = Junction Temperature ( $^{\circ}\text{C}$ )
- $\theta_{JA}$  = Thermal Resistance (Junction-to-Ambient)
- $P_D$  = Power Dissipation at a  $T_J$
- $T_A$  = Ambient Temperature ( $^{\circ}\text{C}$ )

### Example of LCX $T_J$ Calculation

#### 1. Calculate Current Consumption:

For example, the LCX244's  $C_P$  is 25pF. Let  $V_{CC} = 3\text{V}$ ; operating temperature =  $85^{\circ}\text{C}$ ;  $F_{OUT} = 50\text{MHz}$ ; for 4 outputs switching; hold 2 inputs LOW and 2 inputs HIGH (at  $V_{CC} - 0.6\text{V}$ );  $C_L = 100\text{pF}$ ;  $500\Omega$  pull-down; no pull-up.

$$\left[ 25\text{pF} \times 3\text{V} \sum_{i=1}^4 50\text{MHz} \right] + 0.3\text{mA}(2)$$

$$= 15\text{mA} + 0.6\text{mA} = 15.6\text{mA}$$

These unloaded terms contribute only 10% of the total  $I_{CC}$  current.

$$(2.8\text{V} - 0.2\text{V}) \sum_{i=1}^4 100\text{pF}(50\text{MHz}) + \sum_{i=1}^6 \frac{2.8\text{V}}{500\Omega}$$

$$= 52\text{mA} + 33.6\text{mA} = 85.6\text{mA}$$

In this example, terms three and four contribute over 55% of the total  $I_{CC}$  current. This part of  $I_{CC}$  is entirely due to external loading.

$$(2.8\text{V} - 0.2\text{V}) \sum_{i=1}^4 100\text{pF}(50\text{MHz}) + \sum_{i=1}^6 \frac{3\text{V} - 0.2\text{V}}{\infty}$$

$$= 52\text{mA} + 0 = 52\text{mA}$$

These terms are not  $I_{CC}$  currents, but rather currents "sunk" by the lower structure of the device. The total current from all terms is 153.2mA.

#### 2. Finding PD ( $V \times I$ )

When calculating the total power dissipation of the device, the first two terms are multiplied by  $V_{CC}$ , which in this example is

$$3\text{V}(15.6\text{mA}) = 46.8\text{mW}$$

The third and fourth terms are multiplied by the voltage drop across the upper structure of the device,  $V_{CC} - V_{OH}$ . This is approximately 0.2V.

$$0.2\text{V}(85.6\text{mA}) = 17.1\text{mW}$$

The fifth and sixth terms are multiplied by the voltage drop across the lower structure of the device,  $V_{OL}$ .

$$0.2\text{V}(52\text{mA}) = 10.4\text{mW}$$

The total estimated power dissipation of an LCX 244 with 4 outputs switching, at  $85^{\circ}\text{C}$ , with  $V_{CC}=3\text{V}$ , with 2 outputs held static Low, and 2 inputs at 2.4V with 100pF capacitive loads, 500Ω pull-downs, and 50MHz switching frequency is:

$$74.3\text{mW}$$

#### 3. $\theta_{JA}$ Value

The  $\theta_{JA}$  for a 20-pin TSSOP is approximately  $128^{\circ}\text{C/W}$ .

#### 4. Final Calculations for $T_J$ for the LCX244

$T_J = (P_D \times \theta_{JA}) + T_A = (0.0743\text{W} \times 128^{\circ}\text{C/W}) + 85^{\circ}\text{C} = 94.5^{\circ}\text{C}$ . LCX runs cool — well below the point for reliability worries. Using the Arrhenius Equation (Eq 1 on page 247), the time to 0.1% bond failures is approximately 30 years.

### System Considerations

*The manner in which an IC package is mounted and positioned in its surrounding environment will have significant effects on operating junction temperatures. These conditions are under the control of the system designer and are worthy of serious consideration in PC board layout and system ventilation and airflow.*

*Forced-air cooling* will significantly reduce  $\Theta_{JA}$ . Air flow parallel to the long dimension of the package is generally a few percent more effective than air flow perpendicular to the long dimension of the package. In actual board layouts, other components can provide air flow blocking and flow turbulence, which may reflect the net reduction of  $\Theta_{JA}$  of a specific component.

*External heat sinks* applied to an IC package can improve thermal resistance by increasing heat flow to the ambient environment. Heat sink performance will vary by size, material, design, and system air flow. Heat sinks can provide a substantial improvement.

*Package mounting* can affect thermal resistance. Surface mount packages dissipate significant amounts of heat through the leads. Improving heat flow from package leads to ambient will decrease thermal resistance.

- *Metal (copper) traces* on PC boards conduct heat away from the package and dissipate it to the ambient; thus the larger the trace area the lower the thermal resistance.
- *Package stand-off* has a small effect on  $\Theta_{JA}$ . Boards with higher thermal conductivity (ceramic) may show the most pronounced benefit.
- The use of *thermally conductive adhesive* under SO packages can lower thermal resistance by providing a direct heat flow path from the package to board. Naturally high thermal conductivity board material and/or cool board temperatures amplify this effect.
- *High thermal conductive board material* will decrease thermal resistance. A change in board material from epoxy laminate to ceramic will help reduce thermal resistance.

### Conclusion

Thermal management remains a major concern of producers and users of IC's. An increase in  $\Theta_{JA}$  is the major trade-off one must accept for package miniaturization. When the user considers all of the variables that affect the IC junction temperature, he is then prepared to take maximum advantage of the tools, materials and data that are available.

#### References

1. "High Performance ECL Data – ECLinPS and ECLinPS Lite," Motorola, pp. 4–32.
2. "Thermal Considerations for Advanced Logic Families; AN241," Philips Semiconductors

## Ordering Information

### Device Nomenclature

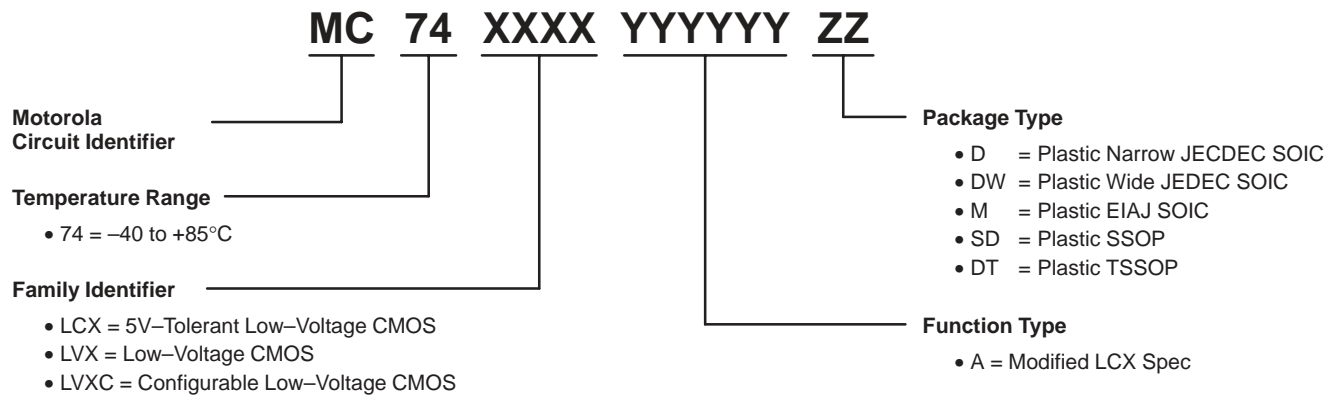



# 16-Pin Packages

## D SUFFIX PLASTIC SOIC PACKAGE CASE 751B-05 ISSUE J

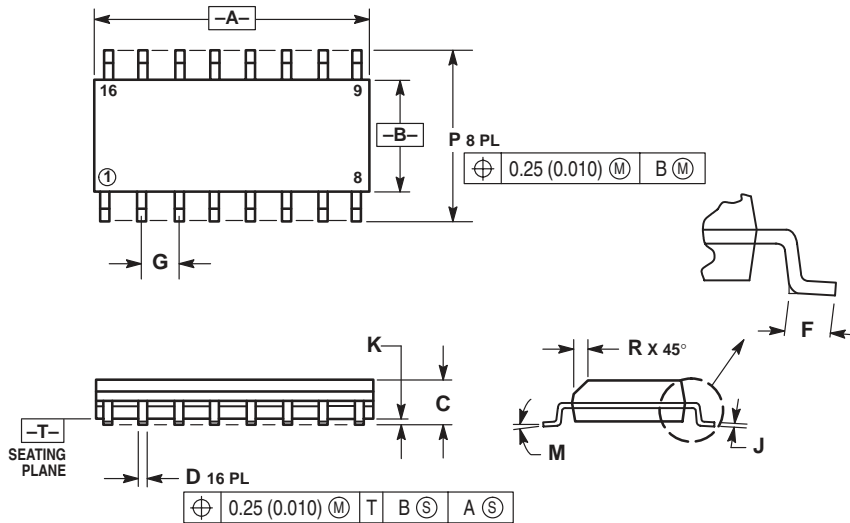

- NOTES:
1. DIMENSIONING AND TOLERANCING PER ANSI Y14.5M, 1982.
  2. CONTROLLING DIMENSION: MILLIMETER.
  3. DIMENSIONS A AND B DO NOT INCLUDE MOLD PROTRUSION.
  4. MAXIMUM MOLD PROTRUSION 0.15 (0.006) PER SIDE.
  5. DIMENSION D DOES NOT INCLUDE DAMBAR PROTRUSION. ALLOWABLE DAMBAR PROTRUSION SHALL BE 0.127 (0.005) TOTAL IN EXCESS OF THE D DIMENSION AT MAXIMUM MATERIAL CONDITION.

DIM	MILLIMETERS		INCHES	
	MIN	MAX	MIN	MAX
A	9.80	10.00	0.386	0.393
B	3.80	4.00	0.150	0.157
C	1.35	1.75	0.054	0.068
D	0.35	0.49	0.014	0.019
F	0.40	1.25	0.016	0.049
G	1.27 BSC		0.050 BSC	
J	0.19	0.25	0.008	0.009
K	0.10	0.25	0.004	0.009
M	0°	7°	0°	7°
P	5.80	6.20	0.229	0.244
R	0.25	0.50	0.010	0.019

## M SUFFIX PLASTIC SOIC EIAJ PACKAGE CASE 966-01 ISSUE O

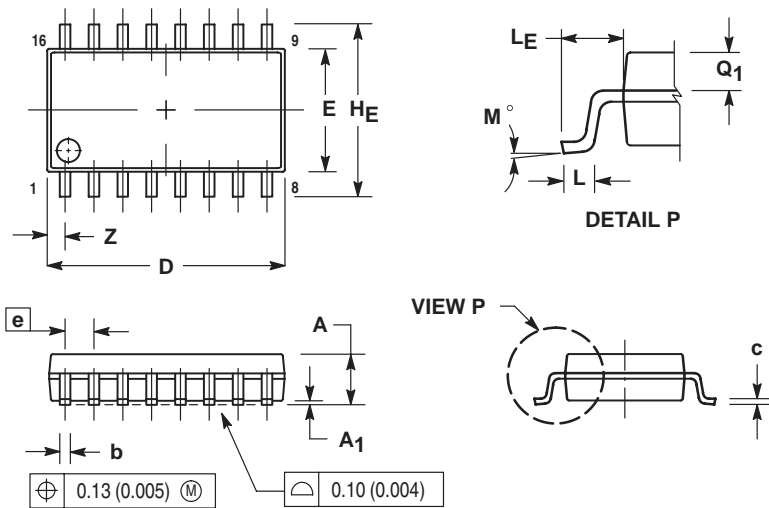

- NOTES:
1. DIMENSIONING AND TOLERANCING PER ANSI Y14.5M, 1982.
  2. CONTROLLING DIMENSION: MILLIMETER.
  3. DIMENSIONS D AND E DO NOT INCLUDE MOLD FLASH OR PROTRUSIONS AND ARE MEASURED AT THE PARTING LINE. MOLD FLASH OR PROTRUSIONS SHALL NOT EXCEED 0.15 (0.006) PER SIDE.
  4. TERMINAL NUMBERS ARE SHOWN FOR REFERENCE ONLY.
  5. THE LEAD WIDTH DIMENSION (b) DOES NOT INCLUDE DAMBAR PROTRUSION. ALLOWABLE DAMBAR PROTRUSION SHALL BE 0.08 (0.003) TOTAL IN EXCESS OF THE LEAD WIDTH DIMENSION AT MAXIMUM MATERIAL CONDITION. DAMBAR CANNOT BE LOCATED ON THE LOWER RADIUS OR THE FOOT. MINIMUM SPACE BETWEEN PROTRUSIONS AND ADJACENT LEAD TO BE 0.46 (0.018).

DIM	MILLIMETERS		INCHES	
	MIN	MAX	MIN	MAX
A	---	2.05	---	0.081
A <sub>1</sub>	0.05	0.20	0.002	0.008
b	0.35	0.50	0.014	0.020
c	0.18	0.27	0.007	0.011
D	9.90	10.50	0.390	0.413
E	5.10	5.45	0.201	0.215
e	1.27 BSC		0.050 BSC	
HE	7.40	8.20	0.291	0.323
L	0.50	0.85	0.020	0.033
LE	1.10	1.50	0.043	0.059
M	0°	10°	0°	10°
Q <sub>1</sub>	0.70	0.90	0.028	0.035
Z	---	0.78	---	0.031



16-Pin Packages (continued)

**SD SUFFIX**  
**PLASTIC SSOP PACKAGE**  
 CASE 940B-03  
 ISSUE B

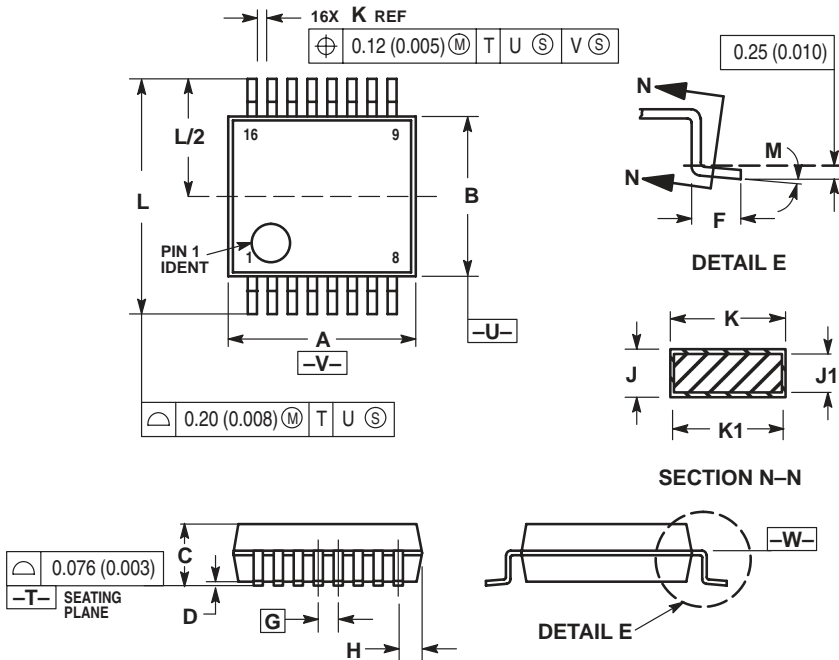

- NOTES:
- 6 DIMENSIONING AND TOLERANCING PER ANSI Y14.5M, 1982.
  - 7 CONTROLLING DIMENSION: MILLIMETER.
  - 8 DIMENSION A DOES NOT INCLUDE MOLD FLASH, PROTRUSIONS OR GATE BURRS. MOLD FLASH OR GATE BURRS SHALL NOT EXCEED 0.15 (0.006) PER SIDE.
  - 9 DIMENSION B DOES NOT INCLUDE INTERLEAD FLASH OR PROTRUSION. INTERLEAD FLASH OR PROTRUSION SHALL NOT EXCEED 0.15 (0.006) PER SIDE.
  - 10 DIMENSION K DOES NOT INCLUDE DAMBAR PROTRUSION/INTRUSION. ALLOWABLE DAMBAR PROTRUSION SHALL BE 0.13 (0.005) TOTAL IN EXCESS OF K DIMENSION AT MAXIMUM MATERIAL CONDITION. DAMBAR INTRUSION SHALL NOT REDUCE DIMENSION K BY MORE THAN 0.07 (0.002) AT LEAST MATERIAL CONDITION.
  - 11 TERMINAL NUMBERS ARE SHOWN FOR REFERENCE ONLY.
  - 12 DIMENSION A AND B ARE TO BE DETERMINED AT DATUM PLANE -W-.

DIM	MILLIMETERS		INCHES	
	MIN	MAX	MIN	MAX
A	6.07	6.33	0.238	0.249
B	5.20	5.38	0.205	0.212
C	1.73	1.99	0.068	0.078
D	0.05	0.21	0.002	0.008
F	0.63	0.95	0.024	0.037
G	0.65 BSC		0.026 BSC	
H	0.73	0.90	0.028	0.035
J	0.09	0.20	0.003	0.008
J1	0.09	0.16	0.003	0.006
K	0.25	0.38	0.010	0.015
K1	0.25	0.33	0.010	0.013
L	7.65	7.90	0.301	0.311
M	0°	8°	0°	8°

**DT SUFFIX**  
**PLASTIC TSSOP PACKAGE**  
 CASE 948F-01  
 ISSUE O

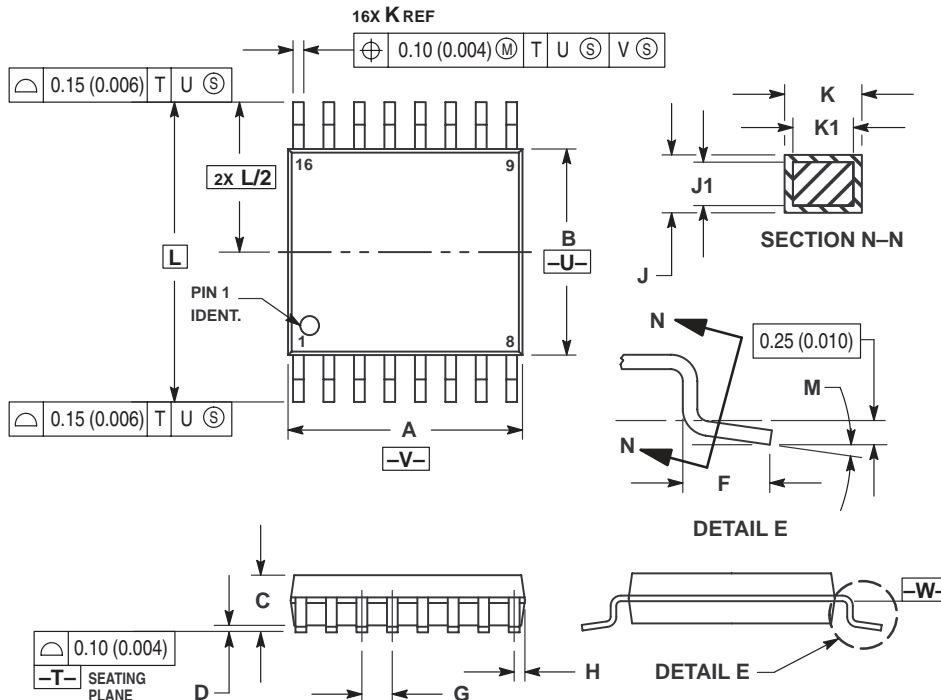

- NOTES:
- 1 DIMENSIONING AND TOLERANCING PER ANSI Y14.5M, 1982.
  - 2 CONTROLLING DIMENSION: MILLIMETER.
  - 3 DIMENSION A DOES NOT INCLUDE MOLD FLASH, PROTRUSIONS OR GATE BURRS. MOLD FLASH OR GATE BURRS SHALL NOT EXCEED 0.15 (0.006) PER SIDE.
  - 4 DIMENSION B DOES NOT INCLUDE INTERLEAD FLASH OR PROTRUSION. INTERLEAD FLASH OR PROTRUSION SHALL NOT EXCEED 0.25 (0.010) PER SIDE.
  - 5 DIMENSION K DOES NOT INCLUDE DAMBAR PROTRUSION. ALLOWABLE DAMBAR PROTRUSION SHALL BE 0.08 (0.003) TOTAL IN EXCESS OF THE K DIMENSION AT MAXIMUM MATERIAL CONDITION.
  - 6 TERMINAL NUMBERS ARE SHOWN FOR REFERENCE ONLY.
  - 7 DIMENSION A AND B ARE TO BE DETERMINED AT DATUM PLANE -W-.

DIM	MILLIMETERS		INCHES	
	MIN	MAX	MIN	MAX
A	4.90	5.10	0.193	0.200
B	4.30	4.50	0.169	0.177
C	—	1.20	—	0.047
D	0.05	0.15	0.002	0.006
F	0.50	0.75	0.020	0.030
G	0.65 BSC		0.026 BSC	
H	0.18	0.28	0.007	0.011
J	0.09	0.20	0.004	0.008
J1	0.09	0.16	0.004	0.006
K	0.19	0.30	0.007	0.012
K1	0.19	0.25	0.007	0.010
L	6.40 BSC		0.252 BSC	
M	0°	8°	0°	8°