

# OF CIRCUITS "XX"	DIM "A"	DIM "B"	ASSEMBLY MATERIAL NO. (-C-H OPT)	ASSEMBLY MATERIAL NO. (-C-H-50 OPT)
02	21.1 [1.83]	9.53 [1.375]	-	387291593
03	30.7 [1.21]	19.05 [1.750]	-	387291594
04	40.2 [1.58]	28.58 [1.125]	-	-
05	49.7 [1.96]	38.10 [1.500]	-	-
06	59.2 [2.33]	47.63 [1.875]	-	-
07	68.8 [2.71]	57.15 [2.250]	-	-
08	78.3 [3.08]	66.68 [2.625]	-	-
09	87.8 [3.46]	76.20 [3.000]	-	-
10	97.3 [3.83]	85.73 [3.375]	-	-
11	106.9 [4.21]	95.25 [3.750]	-	-
12	116.4 [4.58]	104.78 [4.125]	-	-
13	125.9 [4.96]	114.30 [4.500]	-	-
14	135.5 [5.33]	123.83 [4.875]	-	-
15	145.0 [5.71]	133.35 [5.250]	-	-

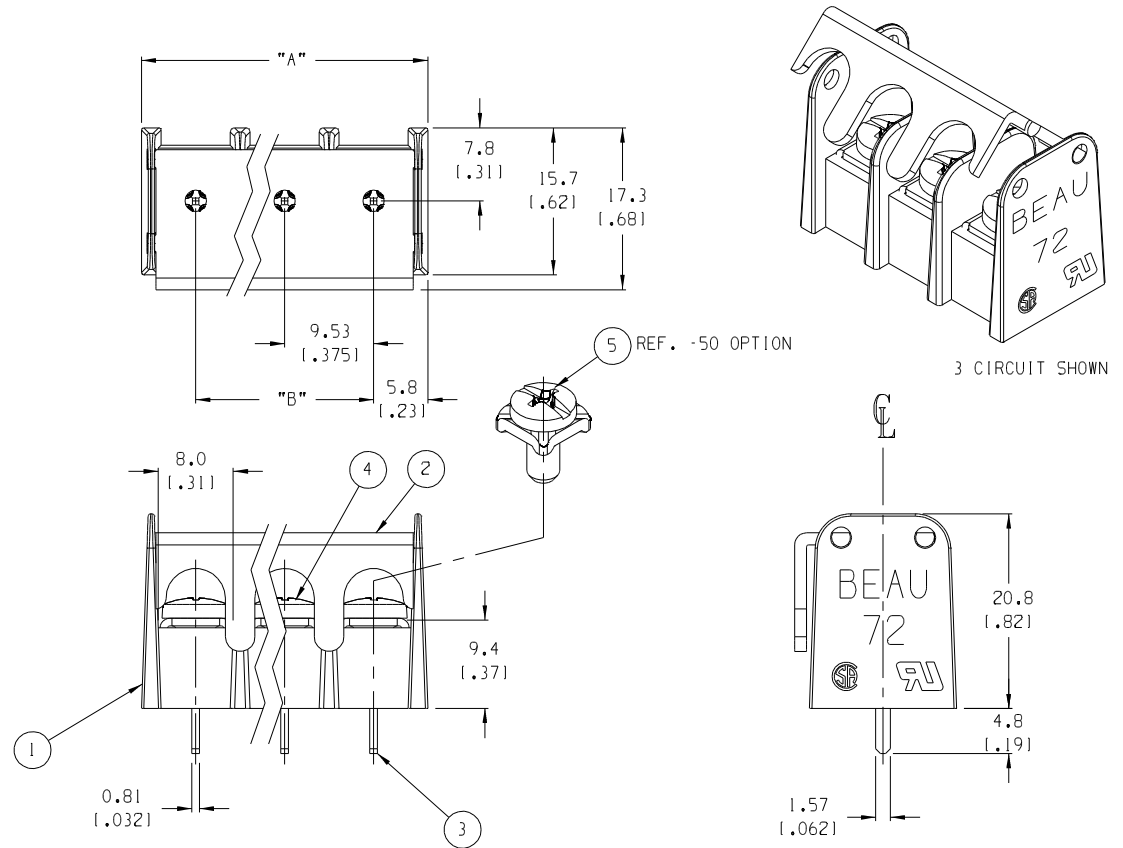

- NOTES:
1. MATERIAL: SEE TABLE
 2. FINISHES: SEE TABLE
 3. PRODUCT SPECIFICATION: NOT REQUIRED
 4. PACKAGING: NOT REQUIRED
 5. MATES WITH: NONE
 6. "XX" REFERS TO THE QUANTITY OF CIRCUITS.

ITEM	QTY.	DESCRIPTION	MATERIAL	FINISH
5	XX	SCREW, #6-32X.250, PANHD, SO. WASHER	STEEL	ZN, CLEAR CHROMATE
4	XX	SCREW, #6-32X.250, BINDING HEAD	STEEL	ZN, CLEAR CHROMATE
3	XX	TERMINAL, PC	BRASS	TIN PLATE
2	1	COVER, HINGED	THERMOPLASTIC	BLACK
1	1	INSULATOR, SR, PC	THERMOPLASTIC	BLACK

EC NO. DRWING CH'K'D APPR'D A	REV DESCRIPTION MAJOR CRITICAL SPC S	QUALITY SYMBOLS		GENERAL TOLERANCES* (UNLESS SPECIFIED)		SCALE 2:1	DESIGN UNITS <input type="checkbox"/> mm <input checked="" type="checkbox"/> INCH	THIRD ANGLE PROJECTION	PROJECT NO. - DIMENSIONS: <input checked="" type="checkbox"/> mm <input type="checkbox"/> INCH <input type="checkbox"/> mm <input type="checkbox"/> ONLY	I SHT REV
		4 PLACES ±.0015 3 PLACES ±.038 ±.005	2 PLACES ±.13 ±.01 1 PLACE ±.3	DRAWN BY & DATE C. YORK 03-29-05	TITLE: 9.53MM [1.375"] SR BTS, PC, ASSY, NO MTG, HINGED COVER					
		ANGULAR: ±2°		CHECKED BY & DATE	MOLEX INCORPORATED					
		DRAFT WHERE APPLICABLE MUST REMAIN WITHIN DIMENSIONS		APPROVED BY & DATE	CAD FILENAME 725XX-C-H	MATERIAL NO. SEE CHART	DRAWING NO. SD-38729-036	SHEET NO. 1 OF 1		
THIS DRAWING CONTAINS INFORMATION THAT IS PROPRIETARY TO MOLEX INCORPORATED AND SHOULD NOT BE USED WITHOUT WRITTEN PERMISSION.									SIZE B	