

Tous droits strictement reserves. Reproduction ou communication a des tiers interdite sous quelque forme que ce soit sans autorisation ecrite du proprietaire. Propriete de c FCI. Droits de reproduction FCI.

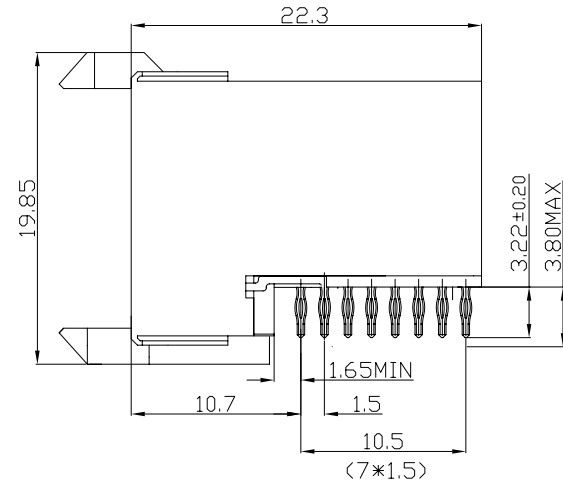

All rights strictly reserved. Reproduction or issue to third parties in any form whatever is not permitted without written authority from the proprietor. Property of FCI. Copyright FCI.

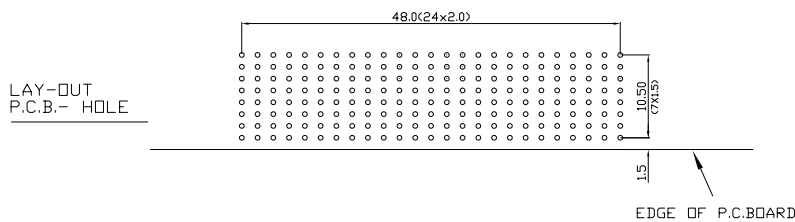
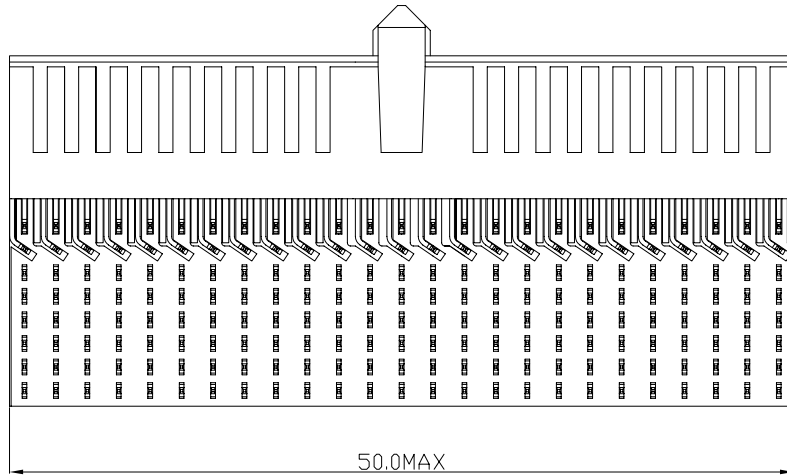
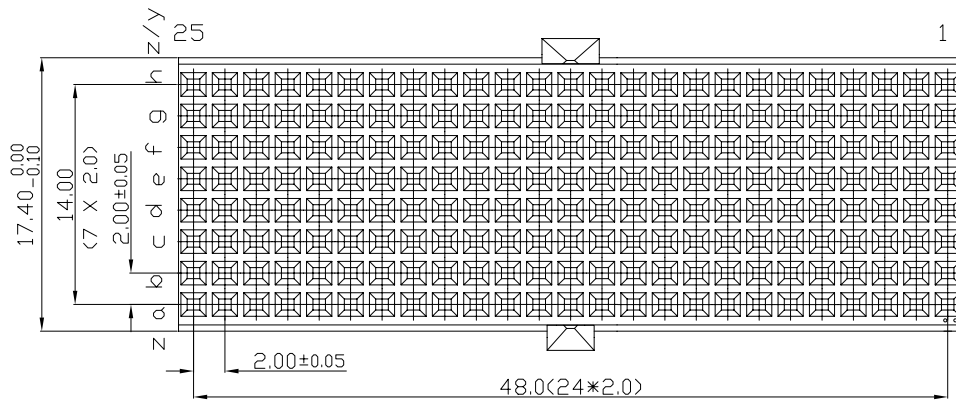

**PERFORMANCE CHARACTERISTICS**

CURRENT RATING 1.5A AT 20°C (FULLY LOADED)  
 1 A AT 70°C (FULLY LOADED)  
 RATED VOLTAGE : 500 V AC (CONT /CONT)  
 OPERATING TEMPERATURE : -55°C TO 125°C  
 CONTACT RESISTANCE 20 MΩ MAX  
 INSERTION FORCE : 0.75N MAX/CONT  
 EXTRACTION FORCE : 0.15N MIN/CONT  
 INSULATION RESISTANCE : 10<sup>4</sup> MΩ MIN

- NOTES 1. LEAD FREE INDICATOR -LF=LEAD FREE  
 PERFORMANCE LEVEL INDICATOR (REF DWG NO.BSC 201844.003)  
 2. THIS PRODUCT IS CSA APPROVED. THIS PRODUCT IS UL RECOGNIZED.  
 3. FOR RECOMMENDED PTH DIMENSIONS REFER DRAWING : BS.A201572.001  
 4. THIS PRODUCT (LF) MEETS EUROPEAN UNION DIRECTIVES AND OTHER COUNTRY REGULATIONS AS DESCRIBED IN GS-22-008

| rev | ecn no                 | dr    | date     |
|-----|------------------------|-------|----------|
| A   | CONVERSION REVISION 01 | KN    | 14-09-01 |
| B   | DG05-0278              | Kasor | 05-08-05 |
| C   | DG07-0362              | Kasor | 05-09-07 |

|            |        |                    |   |  |  |                |                  |              |           |
|------------|--------|--------------------|---|--|--|----------------|------------------|--------------|-----------|
|            |        | www.fciconnect.com |   | tolerance<br>1DEC #0.2 1DEC<br>2DEC #0.1 2DEC<br>ANGLES #1° HOEKEN |  | projection<br> |                  | MM<br>← →    |           |
| Dr         | M,FRET | 11-07-00           | Product family                                | MILLIPICS  |  | size           | A4               | Scale<br>3/1 |           |
| Eng        |        |                    | Spec ref                                      |  |  | ECN            |                  |              |           |
| Chr        |        |                    | Material                                      |  |  |                |                  |              |           |
| Appr       |        |                    |   |  |  |                |                  |              |           |
| title      |        |                    | MPACS 8+2R RA RCP CONN TYPE DE/UPPER SHIELDED |  |  | dwg no         | BS,C ,202258,010 |              | Rev.<br>C |
| catalog no |        |                    | HM2R95PA8100----                              |  |  | CUSTOMER       | sheet 1 of 1     |              |           |