

MATERIAL NUMBER	ALTERNATE NUMBER	STUD SIZE	"S" ±.005/(0.13)	"W" ±.010/(0.25)	"C" MIN. (A1)	"L" MAX. (A1)	PACKAGING	
191980010	BB-807-04	4	.119/(3.02)	.245/(6.22)	.209/(5.31)	.805/(20.45)	LOOSE PIECE	
191980012	BB-807-06	6	.146/(3.71)	.245/(6.22)	.209/(5.31)	.805/(20.45)		
191980014	BB-824-04	4	.119/(3.02)	.295/(7.49)	.211/(5.36)	.804/(20.42)		
191980016	BB-824-06	6	.146/(3.71)	.295/(7.49)	.211/(5.36)	.804/(20.42)		
191980019	BB-824-08	8	.173/(4.39)	.295/(7.49)	.211/(5.36)	.804/(20.42)		
191980021	BB-827-06	6	.146/(3.71)	.362/(9.19)	.269/(6.83)	.927/(23.55)		
191980023	BB-827-08	8	.173/(4.39)	.388/(9.85)	.269/(6.83)	.927/(23.55)		
191980025	BB-827-10	10	.198/(5.03)	.388/(9.85)	.269/(6.83)	.927/(23.55)		
191980011	BB-807-04T	4	.119/(3.02)	.245/(6.22)	.209/(5.31)	.805/(20.45)		TAPE MOUNTED
191980013	BB-807-06T	6	.146/(3.71)	.245/(6.22)	.209/(5.31)	.805/(20.45)		
191980015	BB-824-04T	4	.119/(3.02)	.295/(7.49)	.211/(5.36)	.804/(20.42)		
191980018	BB-824-06T	6	.146/(3.71)	.295/(7.49)	.211/(5.36)	.804/(20.42)		
191980020	BB-824-08T	8	.173/(4.39)	.295/(7.49)	.211/(5.36)	.804/(20.42)		
191980022	BB-827-06T	6	.146/(3.71)	.362/(9.19)	.269/(6.83)	.927/(23.55)		
191980024	BB-827-08T	8	.173/(4.39)	.388/(9.85)	.269/(6.83)	.927/(23.55)		
191980026	BB-827-10T	10	.198/(5.03)	.388/(9.85)	.269/(6.83)	.927/(23.55)		

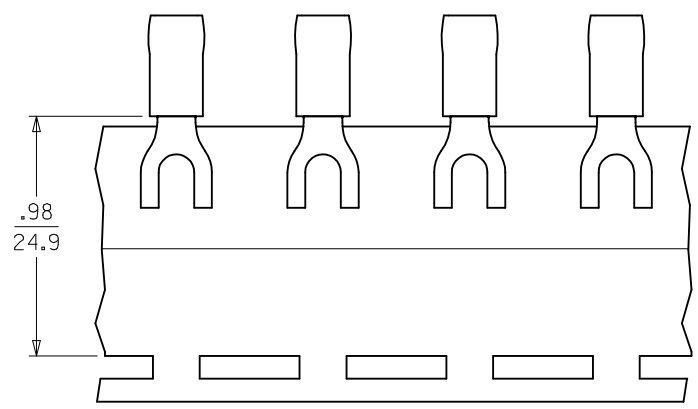

PARTS ON TAPE

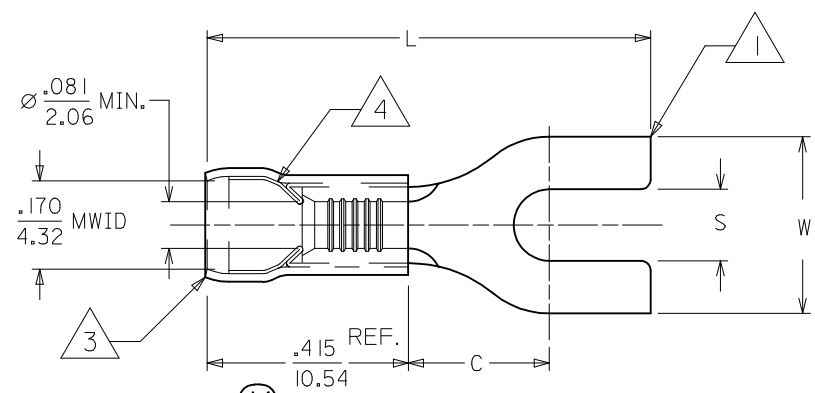

CUSTOMER DRAWING

- NOTES:
1. MATERIAL: COPPER .031/(.79) THICK.
 2. PLATING: ELECTRO-TIN.
 3. INSULATION: NYLON (BLUE)
 4. TIN-PLATED BRASS FUNNEL FERRULE.
 5. ALL DIMENSIONS IN INCHES/(MM).
 6. MWID=MAXIMUM WIRE INSULATION DIAMETER.
 7. PARTS ARE ROHS COMPLIANT. (A1)

CORRECT LENGTH TOL EC NO: IPG2014-2101 DRAWN:ETHRODAHL 2012/10/12 CHKD:JMACNEIL 2012/10/12 APPR:JMACNEIL 2014/06/26	QUALITY SYMBOLS	GENERAL TOLERANCES (UNLESS SPECIFIED)	DIMENSION STYLE	SCALE	DESIGN UNITS	THIRD ANGLE PROJECTION
	▼=0 ▽=0	mm INCH 4 PLACES ± --- ± --- 3 PLACES ± --- ± .005 2 PLACES ± 0.13 ± .01 1 PLACE ± 0.25 ± --- 0 PLACE ± ±	IN/MM	1:1	INCH	
	DESCRIPTION	ANGULAR ± ---° DRAFT WHERE APPLICABLE MUST REMAIN WITHIN DIMENSIONS	DRAWN BY DATE	TITLE		
	A1		HEB 1999/11/12	SPADE TONGUE TERMINAL 16-14 AWG AVIKRIMP		
			CHECKED BY DATE	DOCUMENT NO.		
			RWD 1999/11/12	SD-19198-001		
			APPROVED BY DATE	SHEET NO.		
				1 OF 1		



THIS DRAWING CONTAINS INFORMATION THAT IS PROPRIETARY TO MOLEX INCORPORATED AND SHOULD NOT BE USED WITHOUT WRITTEN PERMISSION