

THIS DRAWING IS UNPUBLISHED. RELEASED FOR PUBLICATION
 © COPYRIGHT 2005 By - ALL RIGHTS RESERVED.

LOC		DIST		REVISIONS			
P	LTR	DESCRIPTION	DATE	DWN	APVD		
GP	00	B	REVISED PER ECO-14-011808	11AUG2014	AP	SB	

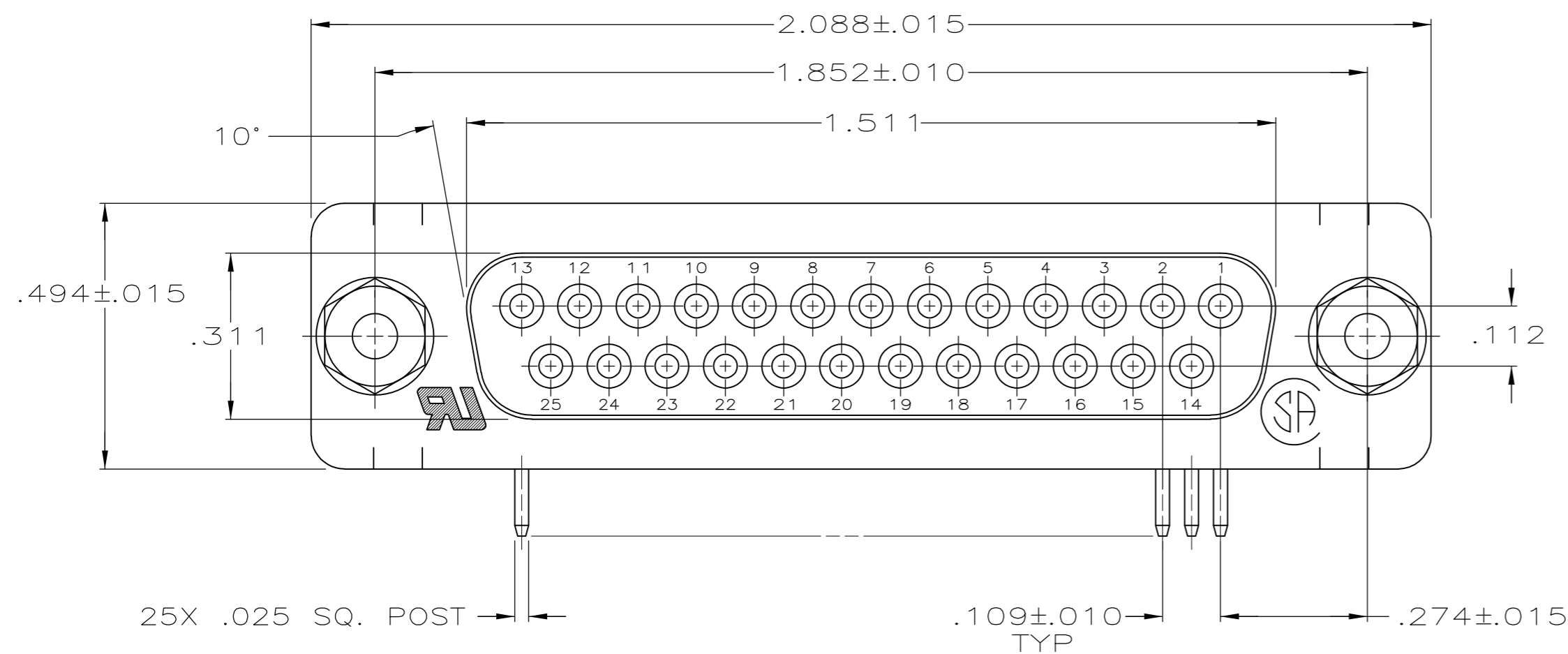

⚠ MOLDDED PARTS: GLASS-FILLED PBT OR GLASS-FILLED NYLON, UL94V-0 RATED. COLOR: BLACK.
 SHELLS & BRACKETS: CARBON STEEL.
 CONTACTS: PHOSPHOR BRONZE.
 SCREWLOCKS & WASHERS: CARBON STEEL.

⚠ SHELLS: .000200 MIN TIN OVER .000100 MIN COPPER.
 BRACKETS: .000200 MIN TIN OVER .000050 MIN COPPER.
 SCREWLOCKS & WASHERS: ZINC PLATED WITH CLEAR CHROMATE COATING.
 CONTACTS: .000030 MIN GOLD FOR A LENGTH OF .100 MIN FROM MATING END, .000100 MIN TIN ON OPPOSITE END, BOTH OVER .000050 MIN NICKEL.
 -OR-
 GOLD FLASH OVER .000030 MIN PALLADIUM NICKEL PLATED FOR A LENGTH OF .100 MIN FROM MATING END, .000100 MIN TIN ON OPPOSITE END, BOTH OVER .000050 MIN NICKEL.

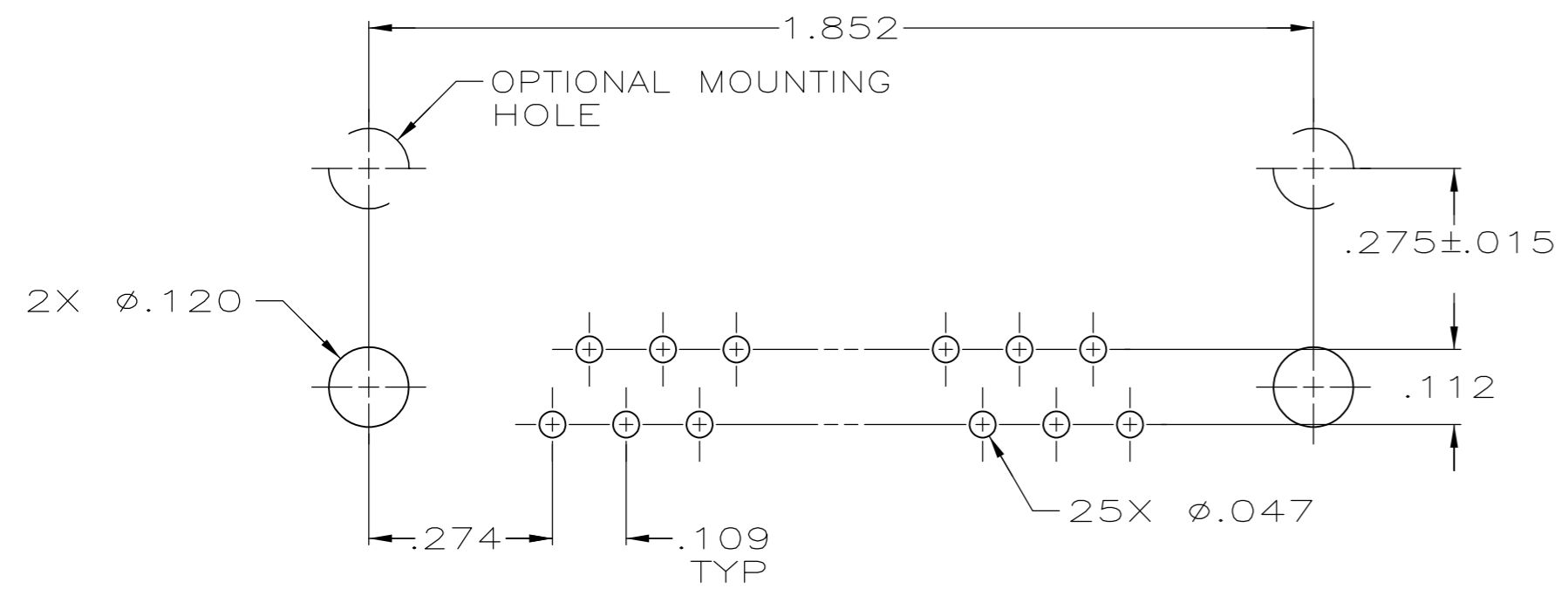
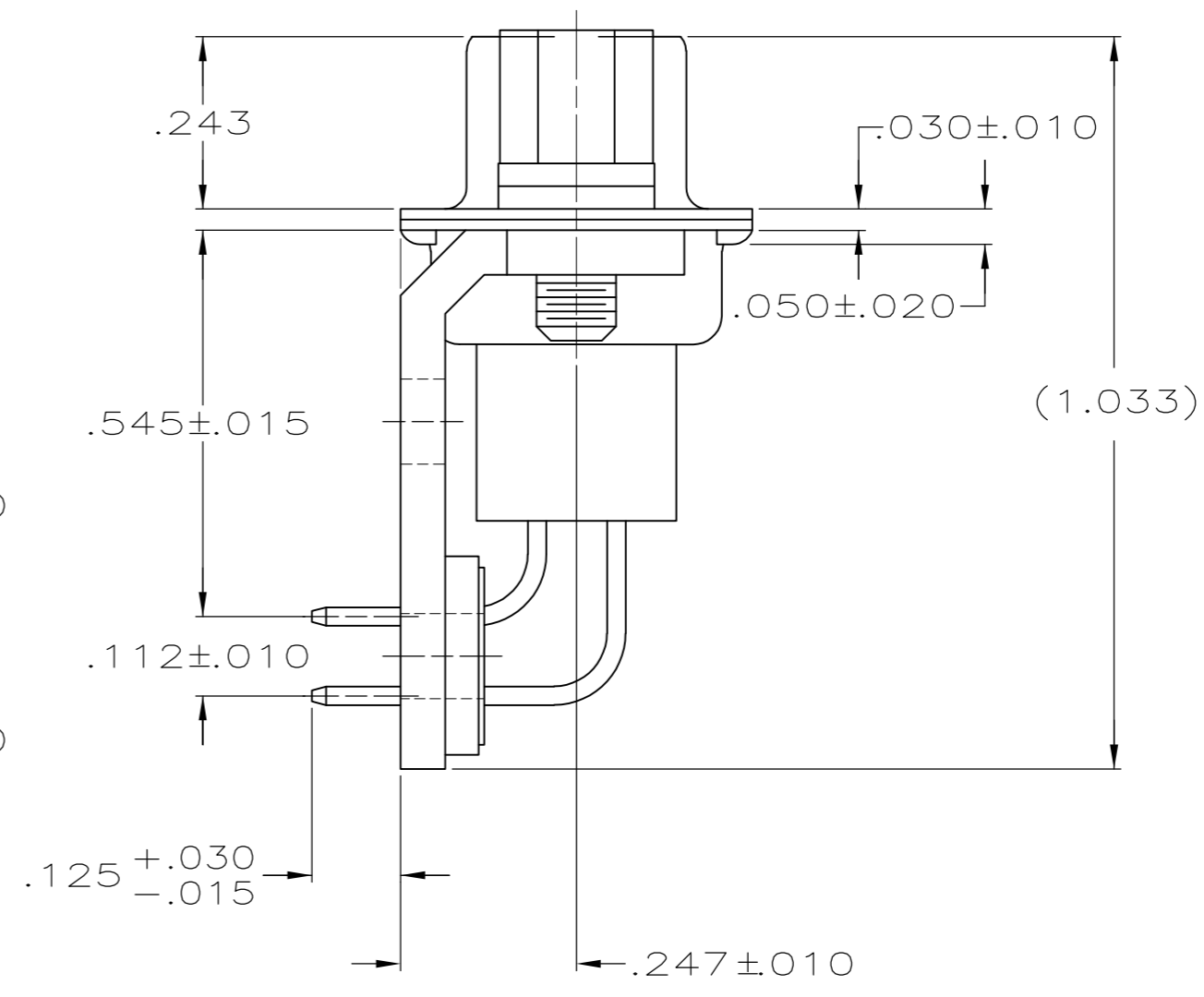
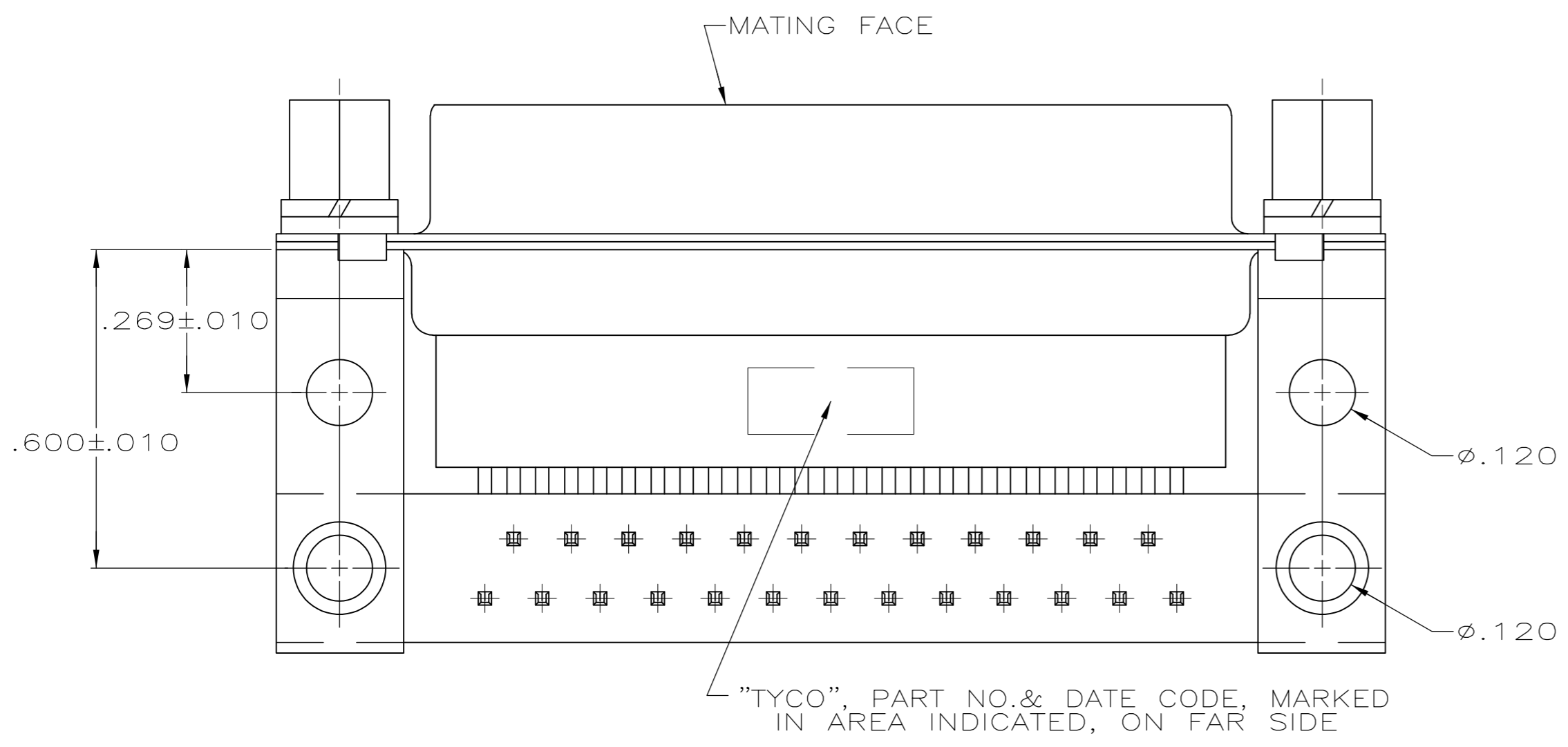

P.C. BOARD MOUNTING DIMENSIONS

5745536-2
 PART NUMBER

THIS DRAWING IS A CONTROLLED DOCUMENT.		DWN D. HENNY 8-31-05		TE Connectivity		
DIMENSIONS: INCHES		CHK S. BOLASH 8-31-05		NAME RECEPTACLE ASSEMBLY, SIZE 3, 25 POSITION, RIGHT ANGLE, .545 SERIES, .025 SQ. POSTS, WITH SCREWLOCKS, AMPLIMITE HDP		
TOLERANCES UNLESS OTHERWISE SPECIFIED:		APVD M. WALMSLEY 8-31-05		PRODUCT SPEC 108-40025		
0 PLC ± - 1 PLC ± - 2 PLC ± - 3 PLC ± .005 4 PLC ± - ANGLES ± 2°		APPLICATION SPEC 114-40013		SIZE A2	CAGE CODE 00779	DRAWING NO C=5745536
MATERIAL 1		FINISH 2	WEIGHT -	SCALE 4:1	SHEET 1 of 1	RESTRICTED TO -
CUSTOMER DRAWING			REV B			