

THIS DRAWING IS UNPUBLISHED. RELEASED FOR PUBLICATION  
 © COPYRIGHT - By - ALL RIGHTS RESERVED.

LOC	DIST	REVISIONS					
GP	00	P	LTR	DESCRIPTION	DATE	DWN	APVD
		S1		REVISED PER ECO-11-004835	11MAR11	RK	HMR

.050±.005 DIA  
 SECTION A-A  
 SCALE 10:1  
 10 PLACES

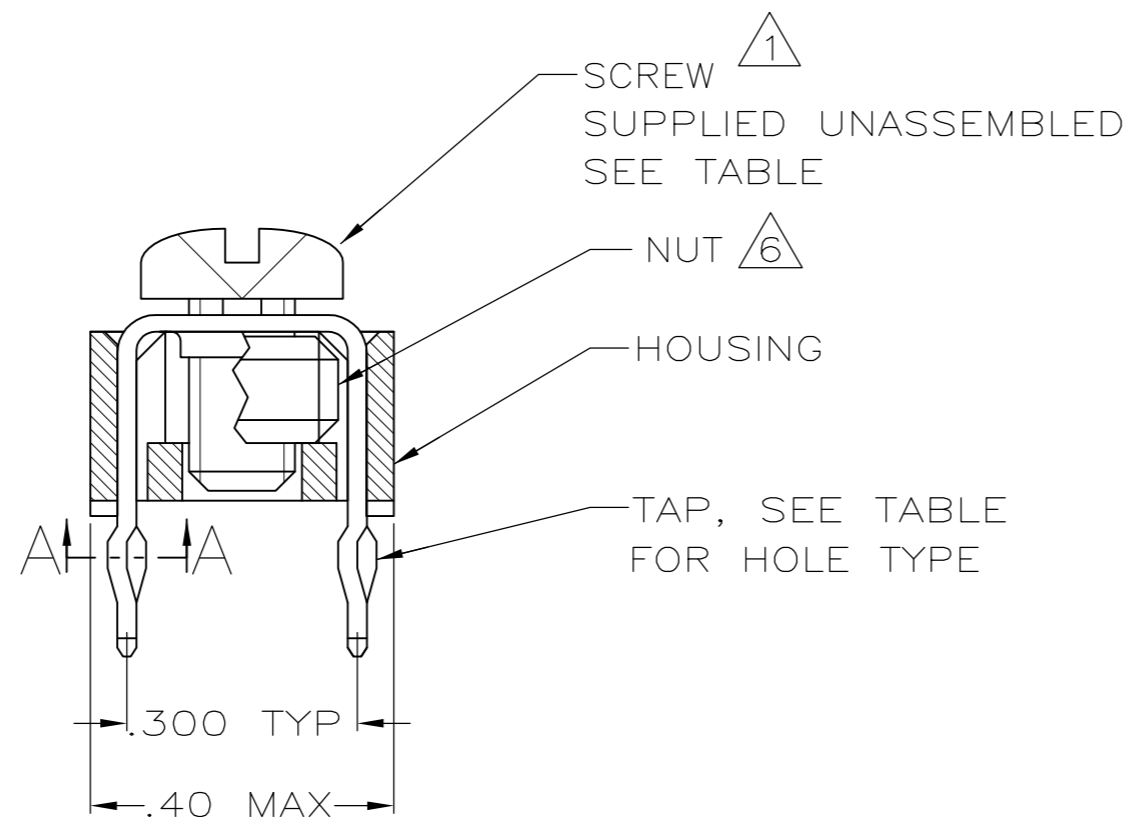
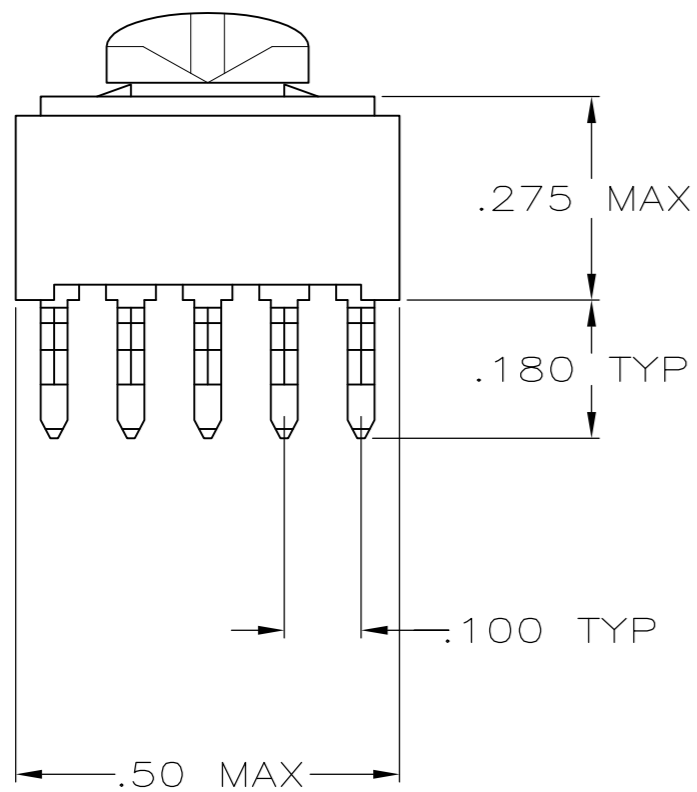

- 1 TO PREVENT THREAD STRIPPING, SCREW TORQUE SHOULD NOT EXCEED 9 IN LBS.
- 2 TAP HOLE IS 6-32UNC-2B, TWO MIN THREADS.
- 3 TAP HOLE IS M4 X 0.7, TWO MIN THREADS.
- 4 PACKAGED BULK.
- 5 PACKAGED INDIVIDUALLY.
- 6 NUT INCREASES TORQUE VALUE TO 26 IN LBS.
- 7 HOUSING: NYLON UL 94V-0. TAP: COPPER ALLOY 735, .025 THICK.
- 8 TAP: .000150 TIN-LEAD OVER .000050 NICKEL.
- 9 CLEARANCE HOLE FOR A 6-32 SCREW.
- 10 TAP: .000150 TIN OVER .000050 NICKEL.

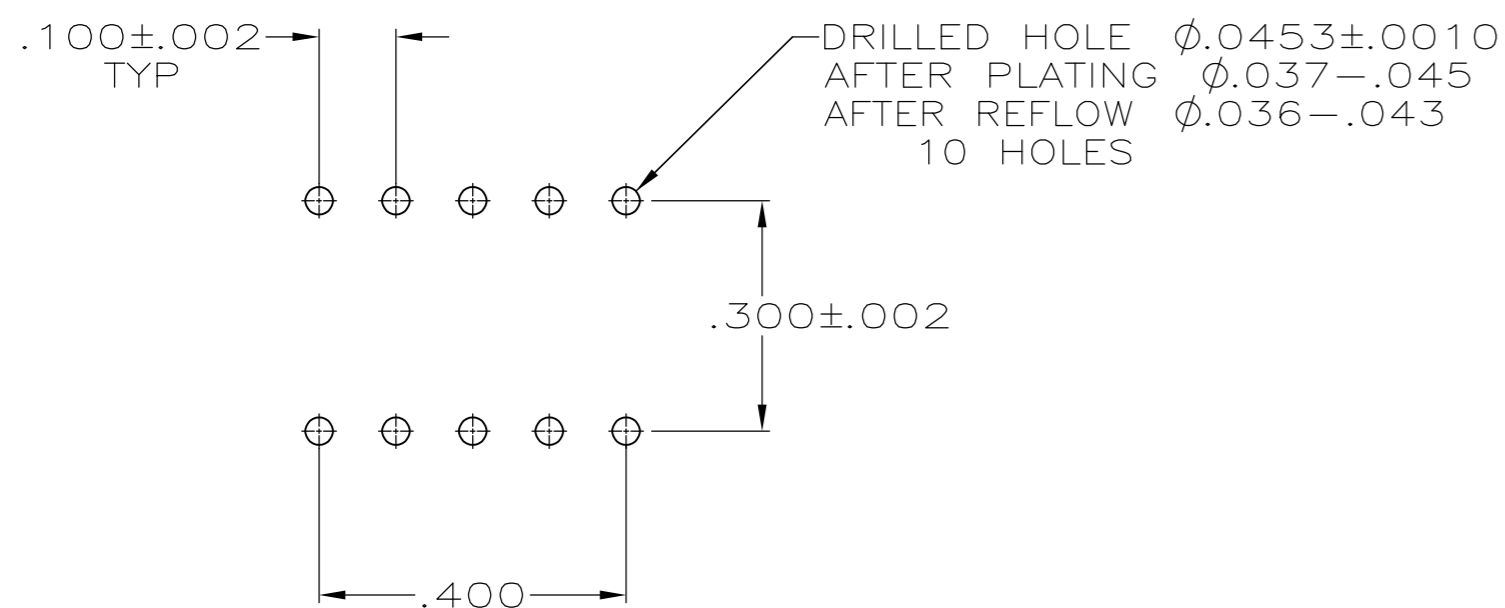

PC BOARD PATTERN

PACKAGE	FINISH	HOLE TYPE	HOUSING COLOR	HOUSING AND TAP ASSEMBLED	SCREW	PART NO.
	4	10	2	BLACK	YES	993879-1 9-55556-0
	4	8	9	BLACK	6 YES (W/NUT)	NO 1-55556-3
	4	8	9	BLACK	6 YES (W/NUT)	993879-1 1-55556-2
OBSOLETE	5	8	2	BLACK	YES	993879-1 1-55556-1
SUPSD BY -9	-	8	3	BLACK	YES	NO 1-55556-0
	4	8	3	BLACK	YES	M4 X 0.7 X 6MM 55556-9
SUPSD BY -4	-	8	2	WHITE	YES	993879-1 55556-8
SUPSD BY -4	-	8	2	GREEN	YES	993879-1 55556-7
SUPSD BY -4	-	8	2	BLUE	YES	993879-1 55556-6
SUPSD BY -4	-	8	2	RED	YES	993879-1 55556-5
	4	8	2	BLACK	YES	993879-1 55556-4
	4	8	2	BLACK	YES	NO 55556-3
OBSOLETE	-	8	2	BLACK	NO	993879-1 55556-2
	-	8	2	BLACK	NO	NO 55556-1

THIS DRAWING IS A CONTROLLED DOCUMENT.

DWN	J.McCLINTON	1-11-88
CHK	R.STONE	1-11-88
APVD	M.GALLOWAY	1-11-88

TE Connectivity

TAP ASSEMBLY, POWER DISTRIBUTION

SIZE	A2	CAGE CODE	00779	DRAWING NO	C=55556	RESTRICTED TO
SCALE	4:1	SHEET	1 OF 1	REV	S1	

CUSTOMER DRAWING