

THIS DRAWING IS UNPUBLISHED.
VERTRAULICHE UNVEROEFFENTLICHTE ZEICHNUNG

RELEASED FOR PUBLICATION
FREI FUER VEROEFFENTLICHUNG

MATED WITH:
PASSEND ZU:

LOC
A1

DIST
-

REVISIONS
AENDERUNGEN

© COPYRIGHT 2000 BY -

ALL RIGHTS RESERVED.
ALLE RECHTE VORBEHALTEN

PROJEKT NR.:

P

LTR

DESCRIPTION
BESCHREIBUNG

DATE

DWN

APVD

B1 1- -1 AND 1- -2 VERSIONS ADDED

23JAN2013

PKS

TK

C ADDED 1394429-3

08SEP2021

CJH

TIM

CI ADDED 1394429-6

10JAN2022

PC

FDP

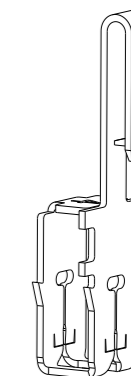
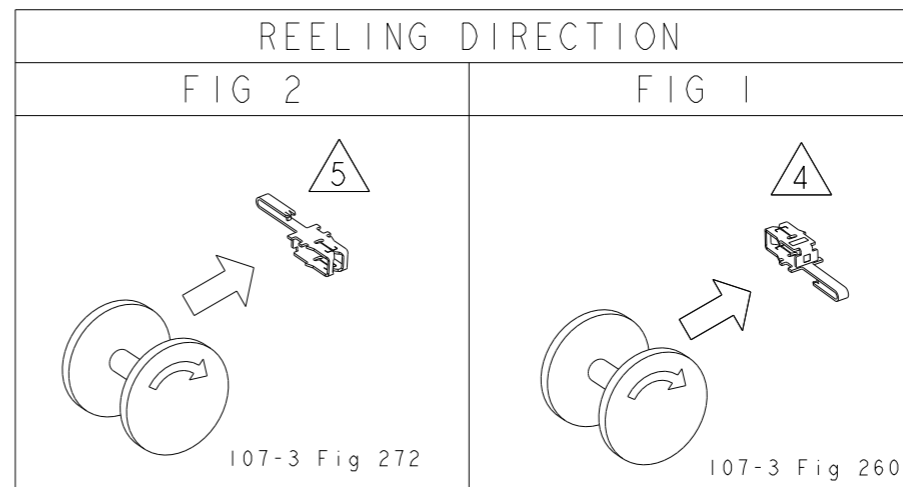
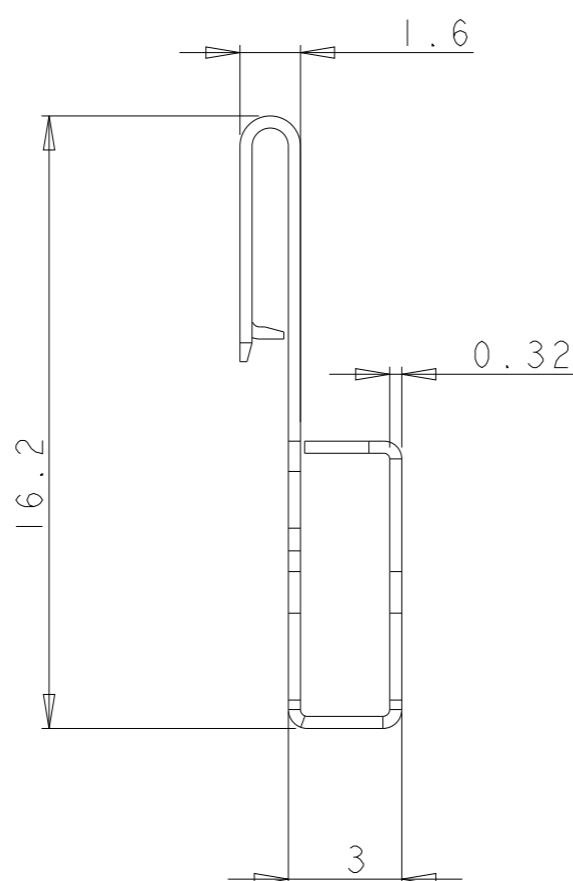
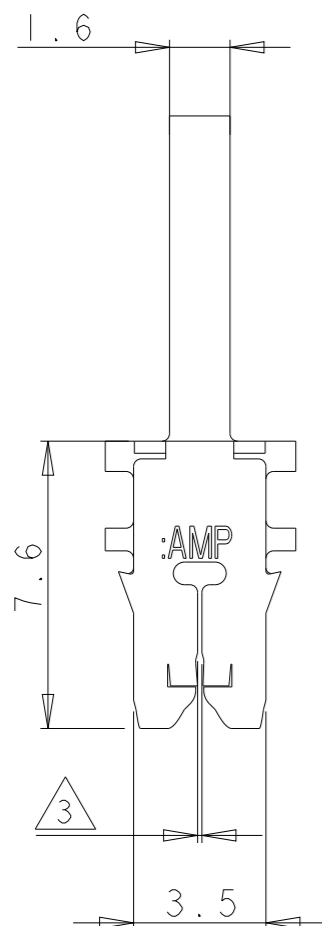

FEED 5.0±0.08

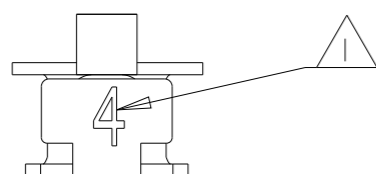

1394429-6	CuZn30	VORVERZINNT	4	7
1394429-3	CuNiSi	VORVERZINNT	4	6
1-1394429-2	CuNiSi	VORVERZINNT	5	
1-1394429-1	CuNiSi	VORVERZINNT	5	
1394429-2	CuZn30	VORVERZINNT	4	
1394429-1	CuNiSi	VORVERZINNT	4	
BESTELL-NR.	WERKSTOFF	OBERFLAECHE	BEMERKUNGEN	

THIS DRAWING IS A CONTROLLED DOCUMENT.
DIESES ZEICHNUNGSDOKUMENT WIRD DURCH AMP INCORPORATED KONTROLLIERT.
AENDERUNGEN, DIE DEM TECHNISCHEN FORTSCHRITT DIENEN, SIND VORBEHALTEN.
DEN JEWELIS LETZTGUELTIGEN AENDERUNGSSTAND ERFAHREN SIE AUF ANFRAGE.

DIMENSIONS:
MASSEINHEITEN:
mm

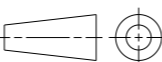

MATERIAL S.TAB.

TOLERANCES UNLESS
OTHERWISE SPECIFIED:
ALLGEMEINTOLERANZEN

0 PLC	±
1 PLC	±0.2
2 PLC	±0.2
3 PLC	±0.2
4 PLC	±
ANGLES/WINKEL	±1°

FINISH/OBERFLAECHE/FARBE
S.TAB.

DWN 08SEP2021

CHUNJIE HU

CHK 08SEP2021

JUSTIN HUANG

APVD 08SEP2021

TIM DING

PRODUCT SPEC

PRODUKTSPEZ.

108-2012

APPLICATION SPEC

VERARBEITUNGSSPEZ.

114-2046

WEIGHT

GEWICHT -

Customer Drawing

NAME

MAG-MATE CONTACT
RAST 5 D

SIZE

A300779

CAGE CODE

G=1394429

DRAWING NO

ZEICHNUNGS-NR.

RESTRICTED TO

NUR FUER

-

SCALE

MASSSTAB 5:1

SHEET

BLATT 1

OF

VON 2

REV

CI



TE Connectivity

THIS DRAWING IS UNPUBLISHED. VERTRAULICHE UNVEROEFFENTLICHTE ZEICHNUNG		RELEASED FOR PUBLICATION FREI FUER VEROEFFENTLICHUNG		MATED WITH: PASSEND ZU:		LOC A1	DIST -	REVISIONS AENDERUNGEN			
© COPYRIGHT 2000 BY -		ALL RIGHTS RESERVED. ALLE RECHTE VORBEHALTEN				P	LTR	DESCRIPTION BESCHREIBUNG	DATE	DWN	APVD
						PROJEKT NR.:	-	SEE SHEET 1	-	-	-

- 7 SLOT CAN ACCEPT SINGLE ALUMINUM WIRE Ø0.28mm OR DOUBLE ALUMINUM WIRE (2XØ0.28mm). SAME SLOT FOR BOTH VARIANTS
- 6 THIS PART IS REELED WITH INTERLEAVING PAPER 1-782504-9 ON PLASTIC REEL 2-973162-0.
- 3 Schlitz geeignet fuer Kupferlackdraht einfach oder doppelt Ø0.18...0.265mm
SLOT ACCEPTS: SINGLE OR DOUBLE COPPER MAGNET WIRE Ø0.18...0.265mm
- 2 Kontaktkammer nach Zeichnung Nr. 411-18517
CONTACT CAVITY ACCORDING DWG-NO. 411-18517
- 1 Kennziffer fuer Lackdrahtbereich (4)
IDENTIFIKATION NO. FOR MAGNET WIRE RANGE (4)

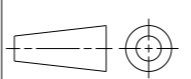
THIS DRAWING IS A CONTROLLED DOCUMENT. <small>DIESES ZEICHNUNGSDOKUMENT WIRD DURCH AMP INCORPORATED KONTROLLIERT. AENDERUNGEN, DIE DEM TECHNISCHEN FORTSCHRITT DIENEN, SIND VORBEHALTEN. DEN JEWELIS LETZTGUELTIGEN AENDERUNGSSTAND ERFAHREN SIE AUF ANFRAGE.</small>		DWN CHUNJIE HU 08SEP2021	 TE Connectivity	
		CHK JUSTIN HUANG 08SEP2021		
DIMENSIONS: MASSEINHEITEN: mm	TOLERANCES UNLESS OTHERWISE SPECIFIED: ALLGEMEINTOLERANZEN	APVD TIM DING 08SEP2021	NAME MAG-MATE CONTACT RAST 5 D	
	0 PLC ± 1 PLC ±0.2 2 PLC ±0.2 3 PLC ±0.2 4 PLC ± ANGLES/WINKEL ±1°	PRODUCT SPEC PRODUKTSPEZ. 108-2012	DRAWING NO ZEICHNUNGS-NR. G=1394429	
MATERIAL S.TAB.	FINISH/OBERFLAECHE/FARBE S.TAB.	APPLICATION SPEC VERARBEITUNGSSPEZ. 114-2046	SIZE A300779	RESTRICTED TO NUR FUER -
		WEIGHT GEWICHT -	SCALE MASSSTAB 5:1	SHEET BLATT 2
		Customer Drawing	/KUNDENZEICHNUNG	OF VON 2
				REV C1