

Customer Information Sheet

DRAWING No.: H2475-XX

IF IN DOUBT - ASK

©

NOT TO SCALE

THIRD ANGLE PROJECTION

ALL DIMENSIONS IN mm

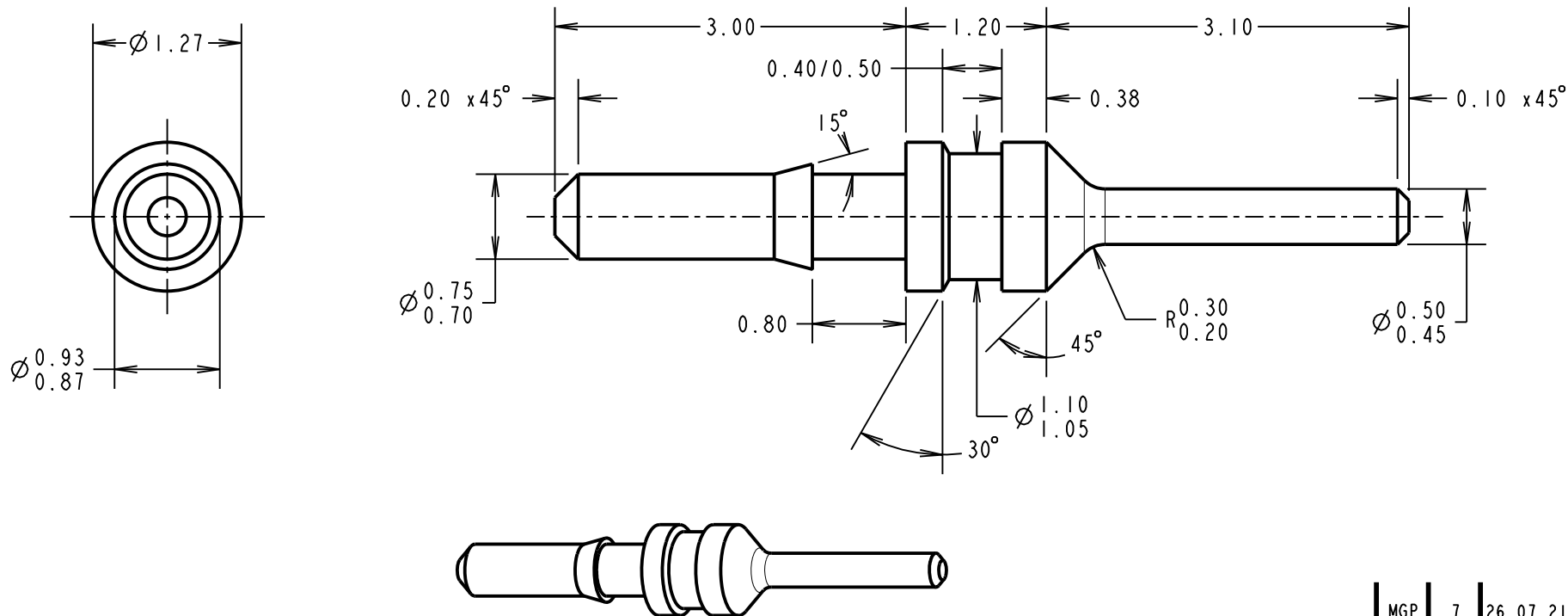

NOTES:

1. UNLESS OTHERWISE STATED, TOLERANCES = ± 0.13
2. RECOMMENDED HOLE SIZE = $\varnothing 0.77/0.85$ mm
3. FOR USE WITH BOARD THICKNESS 1.60mm
4. USE PUNCH AND DIE TOOL PART NUMBER Z2475-00

ORDER CODE: **H2475-XX**

FINISH CODE _____

01 - 100% TIN OVER NICKEL
05 - GOLD

MGP	7	26.07.21	30696
NAME	ISS.	DATE	CN/CO
APPROVED: MGP			
CHECKED: RA			
DRAWN: I. SANDY			
CUSTOMER REF.:			
ASSEMBLY DRG:			

HARWIN

www.harwin.com
technical@harwin.com

THIS DRAWING AND ANY INFORMATION OR DESCRIPTIVE MATTER SET OUT HEREON ARE CONFIDENTIAL AND COPYRIGHT PROPERTY OF THE HARWIN GROUP AND MUST NOT BE DISCLOSED, LOANED, COPIED OR USED FOR MANUFACTURING, TENDERING OR FOR ANY OTHER PURPOSE WITHOUT THEIR WRITTEN PERMISSION.

TOLERANCES

~~X = ± 1 mm
X.X = ± 0.50 mm
X.XX = ± 0.20 mm
X.XXX = ± 0.01 mm~~

ANGLES = $\pm 5^\circ$

UNLESS STATED

MATERIAL:
BRASS CW614N M
TO BS EN 12164

FINISH: SEE ABOVE

S/AREA: mm²

TITLE:
TERMINAL

DRAWING NUMBER:
H2475-XX

SHT
2 OF 2