

T1M-XX-XX-S-V-X-XR

NO OF POSITIONS (PER ROW)
-02, -03, -04, -05, -06, -07,
-08, -09, -10, -11, -12, -13,
-14, -15, -16, -17, -18, -19 & -20

PLATING SPECIFICATION
* -T: TIN PLATING
-GF: 3μ" MIN Au/50μ" Ni IN
CONTACT AND TAIL
-S: 30 μ" SELECTIVE GOLD ON
CONTACT, TIN ON TAIL

ROW SPECIFICATION
-S: SINGLE ROW

TAPE & REEL (SEE NOTES 5 & 6)
-TR: TAPE & REEL
-FR: FULL REEL QTY TAPE & REEL

OPTION
-K: POLYIMIDE FILM
(USE K-DOT-.157-.250-.005,
SEE FIG 3, SHT 3)

SMT TYPE
-V: VERTICAL

* = EXISTING CUSTOMERS ONLY

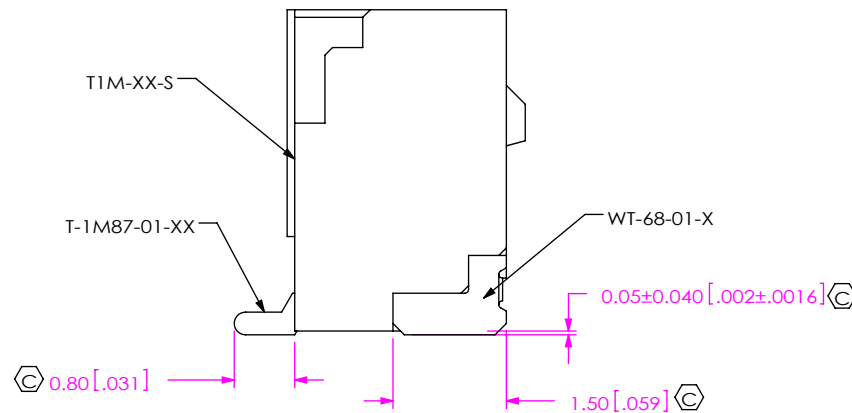
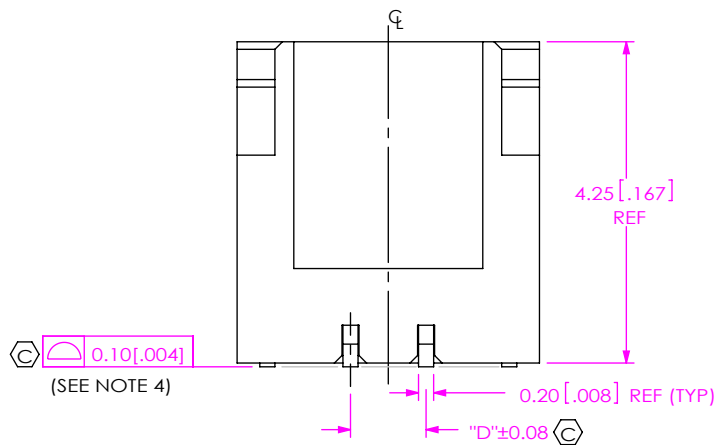
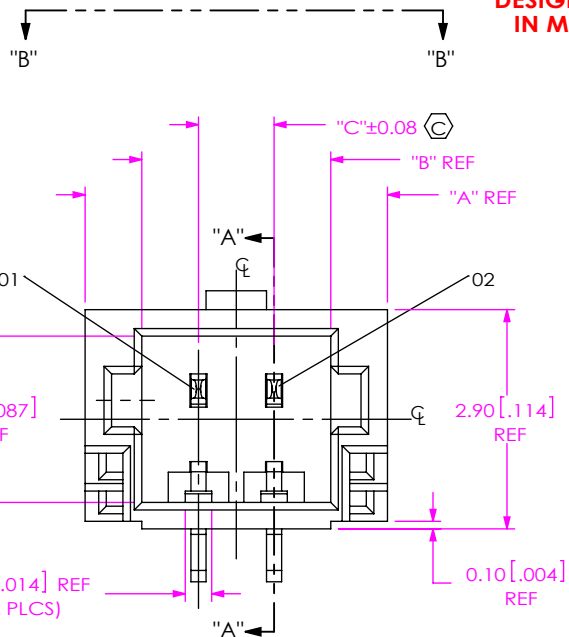
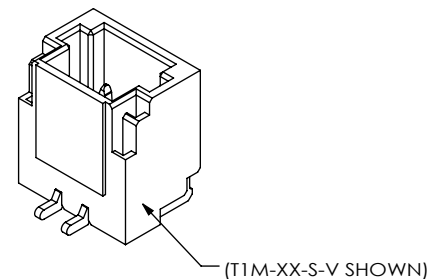

FIG 1
(T1M-02-XX-S-V-XR SHOWN)

NOTES:

1. C REPRESENTS A CRITICAL DIMENSION.
2. MINIMUM PUSHOUT FORCE: SIGNAL: 2.22N [.5 LB], WELD TAB: 4.90N [1 LB].
3. NOTE DELETED.
4. COPLANARITY MEASUREMENT INCLUDES WT'S.
5. ORDERS WILL BE PACKAGED ACCORDING TO THE SAMTEC PACKAGING EFFICIENCY STANDARDS (SPES) FOUND ON WWW.SAMTEC.COM.
6. ATTACH LABEL TO EACH REEL.

TABLE 1

SMT TYPE	BODY PART NUMBER	TERMINAL NUMBER	WT PART NUMBER
-V	T1M-XX-S	T-1M87-01-XX	WT-68-01-X

UNLESS OTHERWISE SPECIFIED,
DIMENSIONS ARE IN MILLIMETERS.
TOLERANCES ARE:
DECIMALS ANGLES
X.X: ±0.3 [.01] 2°
X.XX: ±0.13 [.005]
X.XXX: ±0.051 [.0020]

PROPRIETARY NOTE
THIS DOCUMENT CONTAINS CONFIDENTIAL AND PROPRIETARY INFORMATION AND ALL DESIGN, MANUFACTURING, REPRODUCTION, USE, PATENT RIGHTS AND SALES RIGHTS ARE EXPRESSLY RESERVED BY SAMTEC, INC. THIS DOCUMENT SHALL NOT BE DISCLOSED, IN WHOLE OR PART, TO ANY UNAUTHORIZED PERSON OR ENTITY NOR REPRODUCED, TRANSFERRED OR INCORPORATED IN ANY OTHER PROJECT IN ANY MANNER WITHOUT THE EXPRESS WRITTEN CONSENT OF SAMTEC, INC.

MATERIAL: DO NOT SCALE DRAWING SHEET SCALE: 10:1
INSULATOR: PPA UL 94-V0, COLOR: BLACK
TERMINAL: PHOS BRONZE
WELD TAB: PHOS BRONZE



520 PARK EAST BLVD, NEW ALBANY, IN 47150
PHONE: 812-944-6733 FAX: 812-948-5047
e-Mail: info@SAMTEC.com code 55322

DESCRIPTION:
1MM TERMINAL STRIP
DWG. NO. T1M-XX-XX-S-V-X-XR
BY: ROY LUO 04/08/2010 SHEET 1 OF 3

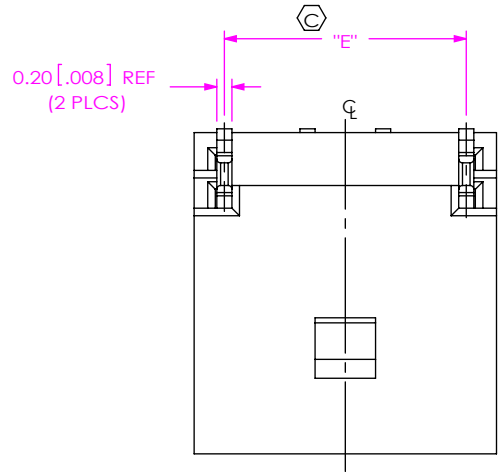

SECTION "B"-"B"
SCALE 10 : 1

TABLE 2												
No. OF POS	"A"		"B"		"C"		"D"		"E"		"F"	
-02	4.00	[0.157]	2.500	[0.0984]	1.000	[0.0394]	1.000	[0.0394]	3.20	[0.126]	0.01	[0.000]
-03	5.00	[0.197]	3.500	[0.1378]	2.000	[0.0787]	2.000	[0.0787]	4.20	[0.165]	0.51	[0.020]
-04	6.00	[0.236]	4.500	[0.1772]	3.000	[0.1181]	3.000	[0.1181]	5.20	[0.205]	1.01	[0.040]
-05	7.00	[0.276]	5.500	[0.2165]	4.000	[0.1575]	4.000	[0.1575]	6.20	[0.244]	1.51	[0.059]
-06	8.00	[0.315]	6.500	[0.2559]	5.000	[0.1969]	5.000	[0.1969]	7.20	[0.283]	2.01	[0.079]
-07	9.00	[0.354]	7.500	[0.2953]	6.000	[0.2362]	6.000	[0.2362]	8.20	[0.323]	2.51	[0.099]
-08	10.00	[0.394]	8.500	[0.3346]	7.000	[0.2756]	7.000	[0.2756]	9.20	[0.362]	3.01	[0.119]
-09	11.00	[0.433]	9.500	[0.3740]	8.000	[0.3150]	8.000	[0.3150]	10.20	[0.402]	3.51	[0.138]
-10	12.00	[0.472]	10.500	[0.4134]	9.000	[0.3543]	9.000	[0.3543]	11.20	[0.441]	4.01	[0.158]
-11	13.00	[0.512]	11.500	[0.4528]	10.000	[0.3937]	10.000	[0.3937]	12.20	[0.480]	4.51	[0.178]
-12	14.00	[0.551]	12.500	[0.4921]	11.000	[0.4331]	11.000	[0.4331]	13.20	[0.520]	5.01	[0.197]
-13	15.00	[0.591]	13.500	[0.5315]	12.000	[0.4724]	12.000	[0.4724]	14.20	[0.559]	5.51	[0.217]
-14	16.00	[0.630]	14.500	[0.5709]	13.000	[0.5118]	13.000	[0.5118]	15.20	[0.598]	6.01	[0.237]
-15	17.00	[0.669]	15.500	[0.6102]	14.000	[0.5512]	14.000	[0.5512]	16.20	[0.638]	6.51	[0.256]
-16	18.00	[0.709]	16.500	[0.6496]	15.000	[0.5906]	15.000	[0.5906]	17.20	[0.677]	7.01	[0.276]
-17	19.00	[0.748]	17.500	[0.6890]	16.000	[0.6299]	16.000	[0.6299]	18.20	[0.717]	7.51	[0.296]
-18	20.00	[0.787]	18.500	[0.7283]	17.000	[0.6693]	17.000	[0.6693]	19.20	[0.756]	8.01	[0.315]
-19	21.00	[0.827]	19.500	[0.7677]	18.000	[0.7087]	18.000	[0.7087]	20.20	[0.795]	8.51	[0.335]
-20	22.00	[0.866]	20.500	[0.8071]	19.000	[0.7480]	19.000	[0.7480]	21.20	[0.835]	9.01	[0.355]

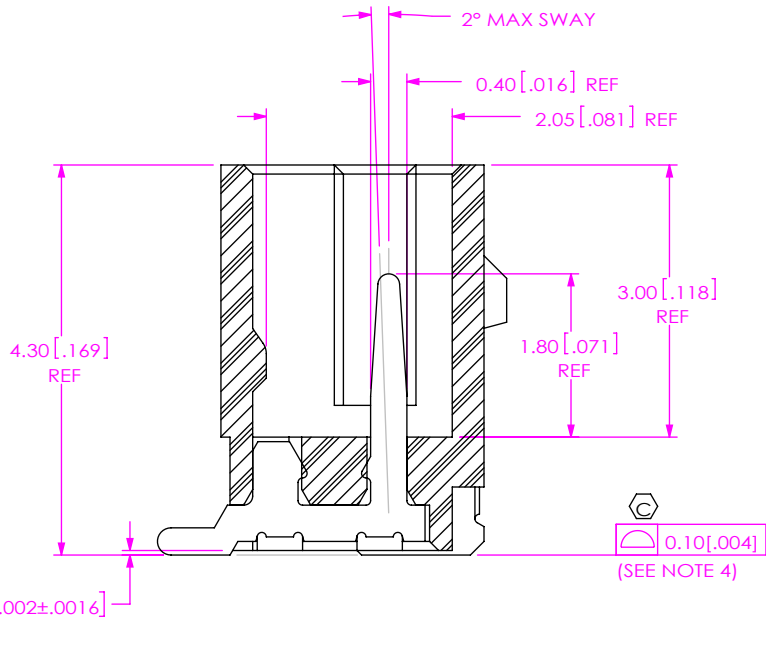

SECTION "A"-"A"
SCALE 12 : 1

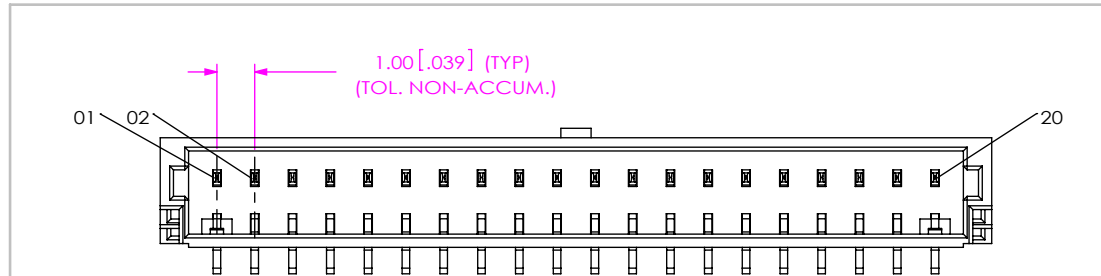

FIG 2
(T1M-20-XX-S-V-XR SHOWN)
(SAME AS FIG 1, EXCEPT AS SHOWN)

PROPRIETARY NOTE
THIS DOCUMENT CONTAINS CONFIDENTIAL AND PROPRIETARY INFORMATION AND ALL DESIGN, MANUFACTURING, REPRODUCTION, USE, PATENT RIGHTS AND SALES RIGHTS ARE EXPRESSLY RESERVED BY SAMTEC, INC. THIS DOCUMENT SHALL NOT BE DISCLOSED, IN WHOLE OR PART, TO ANY UNAUTHORIZED PERSON OR ENTITY NOR REPRODUCED, TRANSFERRED OR INCORPORATED IN ANY OTHER PROJECT IN ANY MANNER WITHOUT THE EXPRESS WRITTEN CONSENT OF SAMTEC, INC.

DO NOT SCALE DRAWING

SHEET SCALE: 5:1



520 PARK EAST BLVD, NEW ALBANY, IN 47150
PHONE: 812-944-6733 FAX: 812-948-5047
e-Mail info@SAMTEC.com code 55322

DESCRIPTION:
1MM TERMINAL STRIP

DWG. NO.
T1M-XX-XX-S-V-XR

BY: ROY LUO 04/08/2010 SHEET 2 OF 3

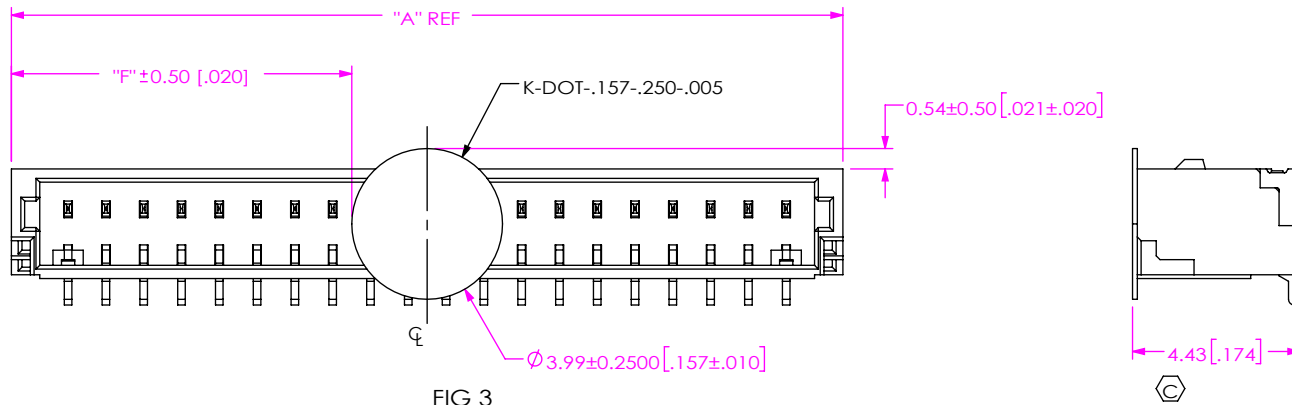

FIG 3
 (T1M-20-XX-S-V-K-TR SHOWN)
 (SAME AS FIG 2, EXCEPT AS SHOWN)

PROPRIETARY NOTE
 THIS DOCUMENT CONTAINS CONFIDENTIAL AND PROPRIETARY INFORMATION AND ALL DESIGN, MANUFACTURING, REPRODUCTION, USE, PATENT RIGHTS AND SALES RIGHTS ARE EXPRESSLY RESERVED BY SAMTEC, INC. THIS DOCUMENT SHALL NOT BE DISCLOSED, IN WHOLE OR PART, TO ANY UNAUTHORIZED PERSON OR ENTITY NOR REPRODUCED, TRANSFERRED OR INCORPORATED IN ANY OTHER PROJECT IN ANY MANNER WITHOUT THE EXPRESS WRITTEN CONSENT OF SAMTEC, INC.

DO NOT SCALE DRAWING

SHEET SCALE: 8:1



520 PARK EAST BLVD, NEW ALBANY, IN 47150
 PHONE: 812-944-6733 FAX: 812-948-5047
 e-Mail info@SAMTEC.com code 55322

DESCRIPTION:	1MM TERMINAL STRIP
DWG. NO.	T1M-XX-XX-S-V-X-R
BY: ROY LUO	04/08/2010 SHEET 3 OF 3