

CCM02 MK2 Series



Features

- Operating life 500,000 cycles
- Insertion force 40N
- EMV
- PCI & PCI ready
- Card detection sealed switch

Typical Applications

- Transaction
- Identification
- POS

Mechanical

Number of Contacts	8
Mechanical life	500,000 cycles min
Card insertion force	10N to 40N
Card extraction force	1N min / 10N max
Contact force	0,2N / 0,50N max
Card detection switch	0,8 N max for actuation (end travel switch actuation force actuates when card is 0,9mm from card stop)
	1,8 N max for complete depression
Vibration Frequency	10 to 500 Hz. Acceleration 50m/s ² Duration 6 hours - amplitude 0,35mm
Max elect. discontinuity	1µs
Shock	Peak value 500 m/s ² – Duration 11 ms 3 shocks in each direction of each axis

Packaging

Tray 30 parts / Cartons 300 parts
Reel 120 parts

Soldering

Compatible with lead free reflow soldering process
For version with security cover, please contact Customer Service for soldering recommendations.

Contact Electrical Data

Insulation resistance	1,000 MΩ min
Resistance	100 mΩ max
Current rating	10 µA min / 1 A max
Dielectric strength	750 Vrms min

Switch Electrical Data

Card detection switch	Normally open
Contact resistance	100 mΩ max
Dielectric strength	250 Vrms min
Current rating	1 mA min / 10 mA max
Maximum power	0.2 VA

Environmental Data

Operating temperature	-40°C to +85°C
Damp heat	IEC 512 test number 11c (10 days)
Salt mist	IEC 512 test number 11f (96 hours)
Card detection switch	Sealed against dust
RoHS compliant	

Designation	Termination	Contact Type	PCI Features		Total Height (mm)	Dimension	PCB version
			I/O Protect	Security Cover			
CCM02-2503LFT	THT	landing			6,25	38,5 X 55,6	4 clips
CCM02-2504LFT	SMT	landing			6,25	38,5 X 55,6	4 clips
CCM02-F503LFT	THT	friction			6,25	38,5 X 55,6	4 clips
CCM02-F504LFT	SMT	friction			6,25	38,5 X 55,6	4 clips
CCM02-F844LFT	SMT	friction	Yes	Yes	6,6	40,5 X 58	4 metal pegs

PCI: I/O Protect

Definition

Special accessory in order to avoid and detect frontal access to data contact. It is electrically connected to the PCB through spring finger contacts.

Process

It must be in open position during the reflow soldering of the connector and has to be locked in closed position after soldering.



I/O Protect locking tool

C&K is proposing a manual tool to lock the I/O protect accessory after soldering.
Ordering code: C-CM02-E50

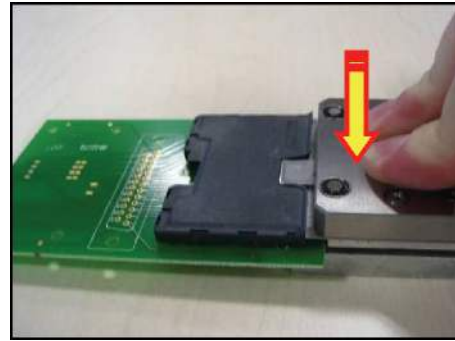
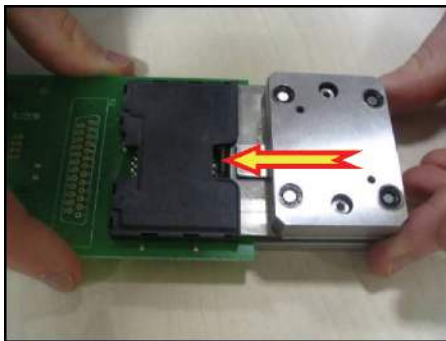

PCI: Security Cover



Definition

It is a multilayer cover placed over the connector to avoid and detect data contact access, especially from the top. It is connected to the PCB through 6 SMT terminals that are soldered at the same time as the other smart card terminals.

Process

Please contact your Sales Representative for advice and recommendations about soldering this version.

CCM02 MK2 Series

CCM02-2503 LFT / CCM02-F503 LFT

Full Size

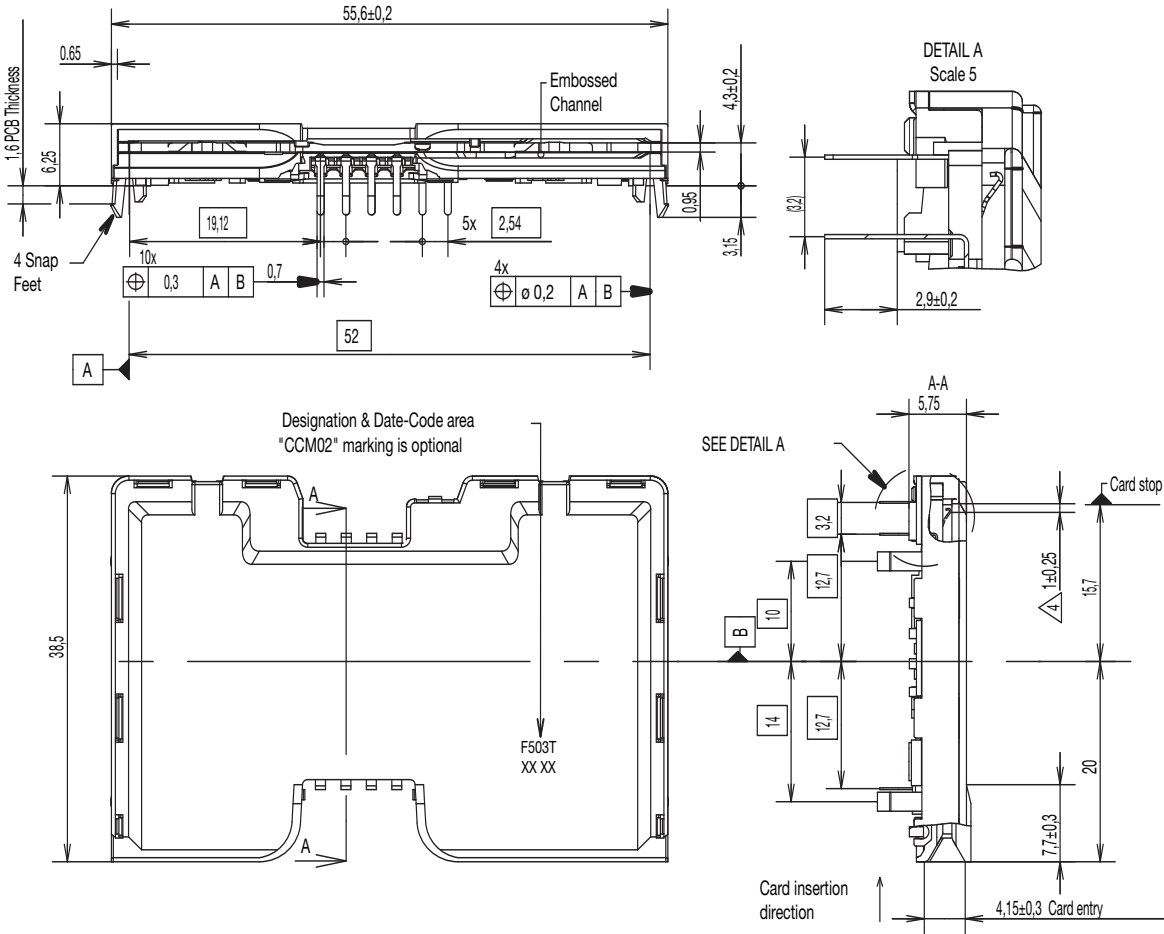

RECOMMENDED PC BOARD LAYOUT
(Component side)

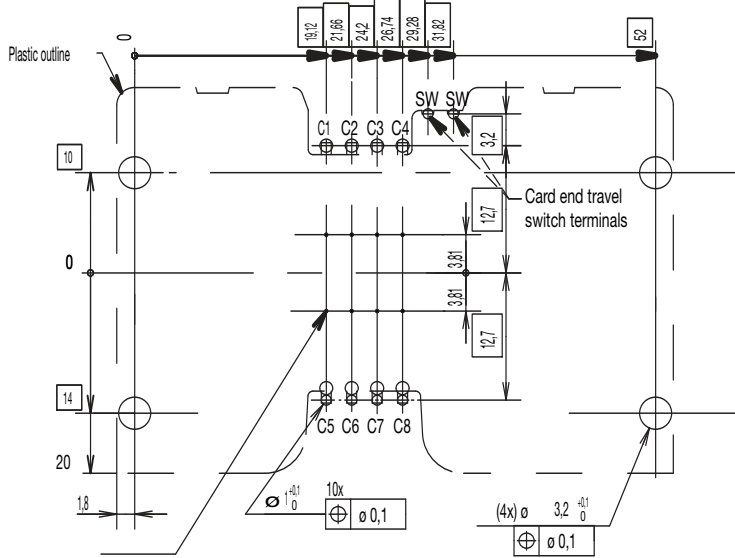

Contact location according to ISO/IEC 7816-2

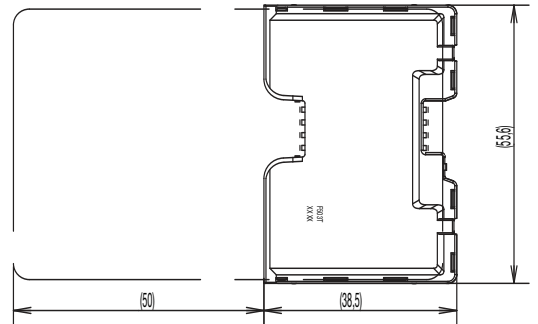

First Angle Projection



Dimensions are shown in mm
Specifications and dimensions subject to change

www.ck-components.com

CCM02 MK2 Series

CCM02-2504 LFT / CCM02-F504 LFT

Full Size

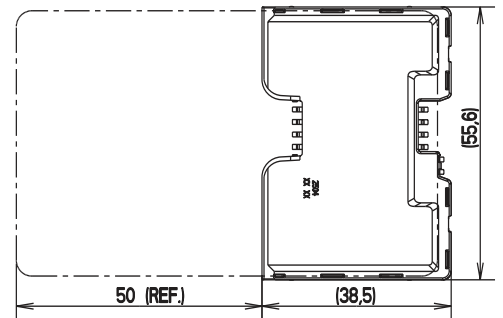
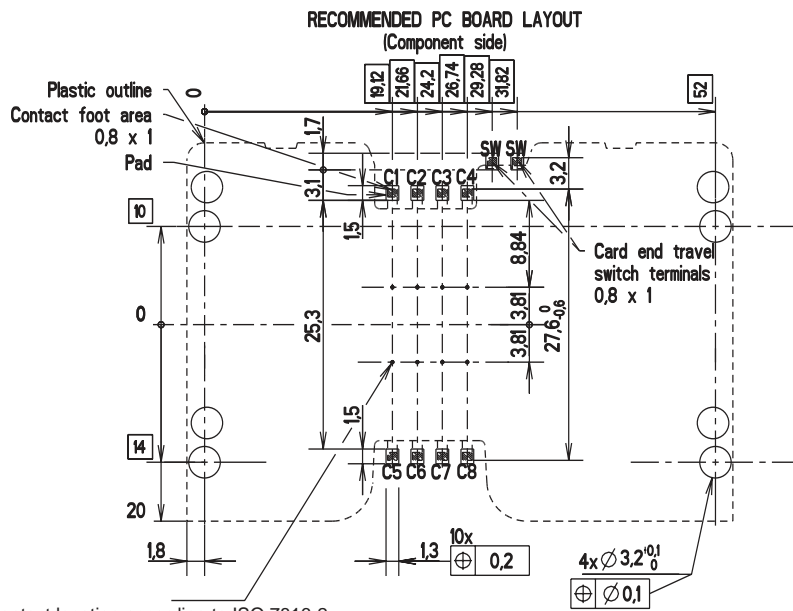
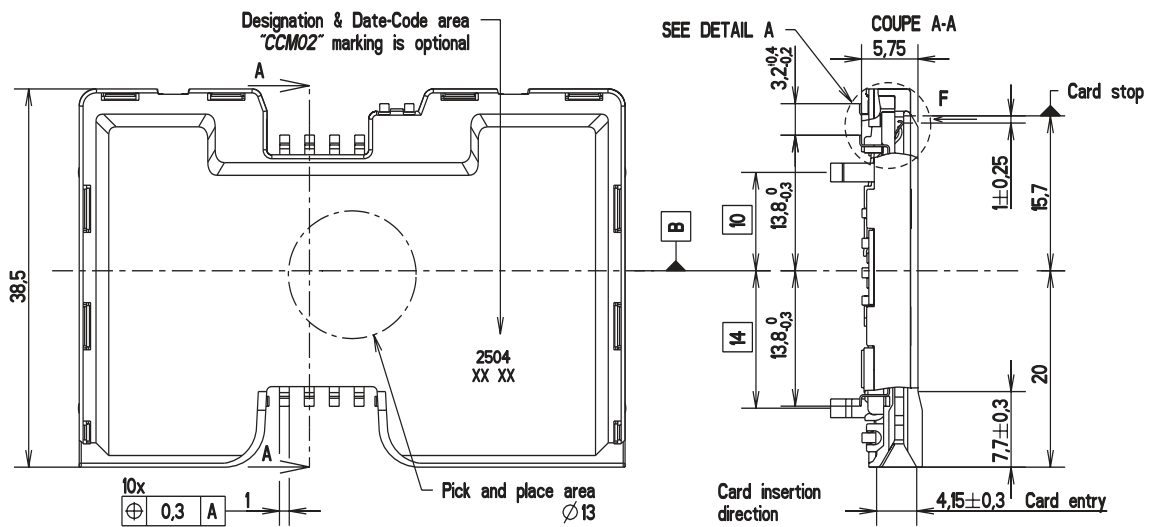
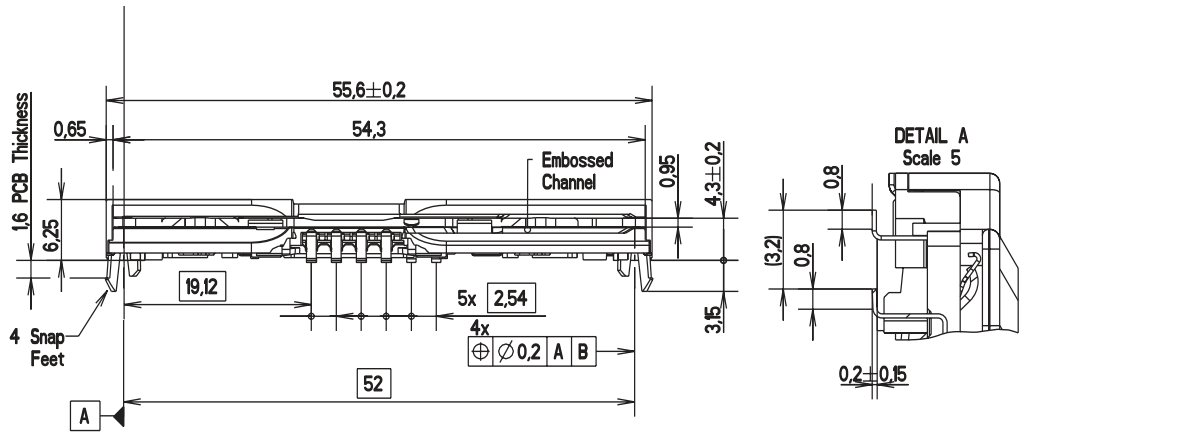

Scale 1

Contact location according to ISO 7816-2



Dimensions are shown in mm
Specifications and dimensions subject to change

www.ck-components.com

CCM02 MK2 Series

CCM02-F844A LFT / CCM02-F844B LFT

Full Size

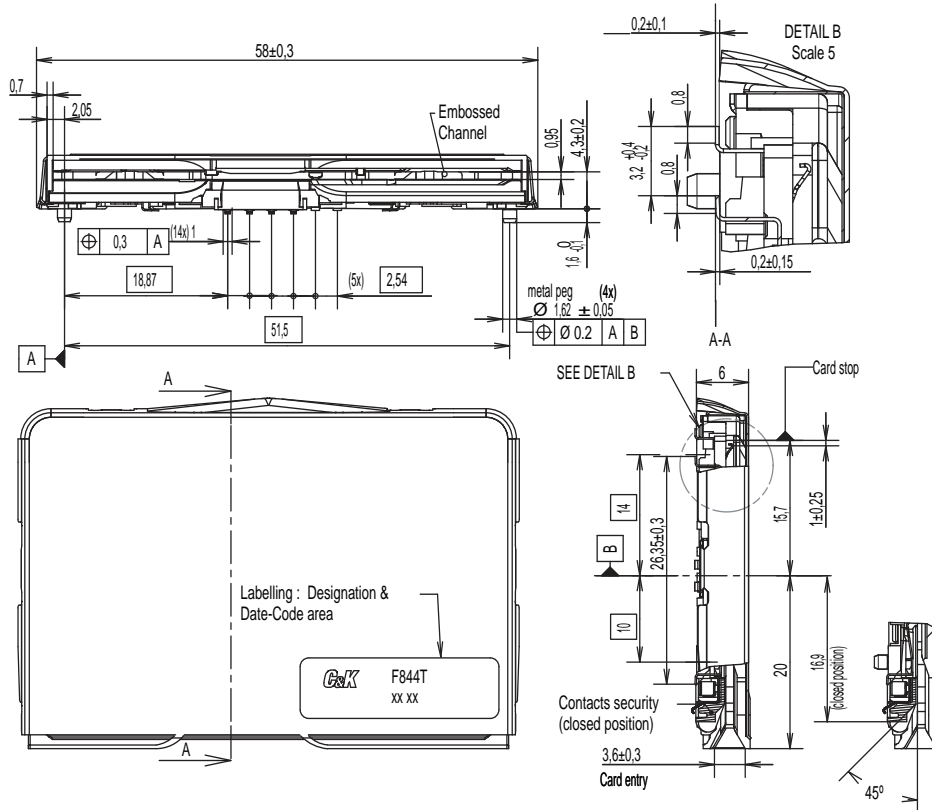

RECOMMENDED PC BOARD LAYOUT
(Component side)

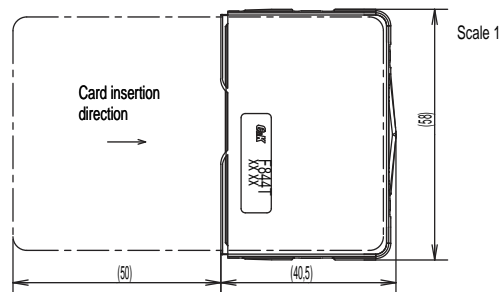
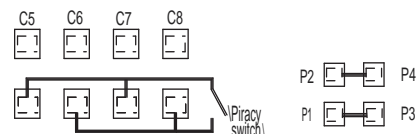
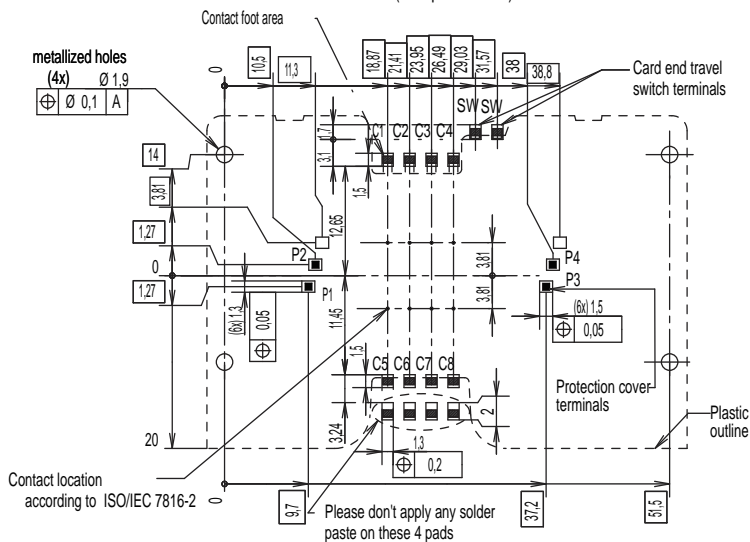

Dimensions are shown in mm
Specifications and dimensions subject to change

www.ck-components.com