

To be read in conjunction with "Introduction to Pellistor Gas Sensors" and Pellistor Application Notes 1, 2, 3, 4, 6 and 7.

INTRODUCTION

The VQ41TSB is a flammable gas sensor optimised for the detection of ammonia in air. It operates by detecting the heat produced by the catalytic oxidation of ammonia on a pair of matched elements. It may be used for the detection of ammonia in air mixtures with concentrations of 600 ppm upwards and is particularly suitable for monitoring over the range zero to 1.5% by volume (zero to 10% LEL). This makes the sensor ideal for use in ammonia refrigerant detection systems intended to comply with BS4434:1989.

Interference from water vapour or carbon dioxide is eliminated by using a matched, inert compensating element. The use of an improved poison resistant construction provides protection against the common substances that can progressively degrade the performance of a sensor and specifically provides a high degree of protection against silicone poisoning agents. In this latter case the protection is very much higher than that provided by standard poison resistant catalytic flammable gas detectors. Tests show no effect on zero or sensitivity to ammonia when exposed to 100 ppm HMDS for greater than one hour.

The VQ41TSB employs new catalyst chemistry and device structure to optimise the ammonia response. There is negligible sensitivity to xylene and very little sensitivity to methane under normal operating conditions, but the device can be used to detect hydrogen and butane.

GENERAL DATA

Electrical

This information relates to the sensor operating in the recommended bridge circuit shown below.

Operation	continuous
Bridge supply	2.0 + 0.1 V
Sensor power consumption	250 mW max
Typical sensor current	100 mA
Sensitivity in SGX Sensortech test block (see note 1):	
minimum	15 mV/% NH ₃
typical	20 mV/% NH ₃
Typical sensitivity to hydrogen	45 mV/% H ₂

Mechanical

Outline	see page 2
Shock (see note 2)	250 g, 5 blows in each plane
Vibration (see note 2)	20 g, 24 cycles from 100 to 3200 Hz

MARKING

Each element carries a unique serial number written on the side of the can. On the detector the number is red and on the compensator it is black.

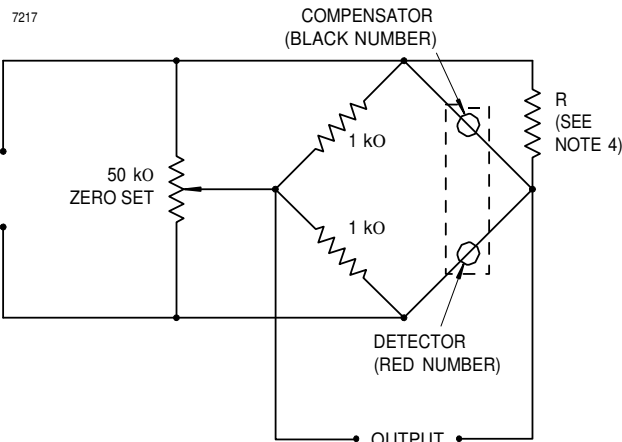

Recommended Bridge Circuit (See note 3)

OPERATION

The output of the sensor is dependent on a complex combustion process established around the sensing beads. It is imperative that the layers of gas around the beads are not disturbed, otherwise the bead temperature and hence device output will change. The devices must therefore be mounted in a draught free environment. Ideally, the elements should be mounted symmetrically side by side with the open ends exposed to the gas being monitored. The elements are supplied with 'O' rings so that gas tight seals may be made between the elements and the mounting. As for all sensors operating on the catalytic oxidation principle, the sensor should be separated from the gas being monitored by a suitable flame arrestor.

In use, the operating voltage should not be allowed to vary by more than the specified +0.1 V, or the output in clean air may change in sympathy. A typical plot of sensitivity against supply voltage is shown in Figure 1.

NOTES

1. The sensitivity is partially influenced by the flow of gas to the elements. Consequently, it is affected by the geometry of the mounting arrangements. The quoted figures were obtained in SGX Sensortech's standard test block, details of which are available on request.
2. Shock and vibration measurements are strongly dependent on the mounting arrangements of the sensor.
3. The values of the resistors in the bridge circuit are suitable for circuits where negligible current is drawn from the output terminals, such as when a high input impedance output amplifier is used.
4. The elements are provided as a matched pair with a trimming resistor R, which must be connected across the compensator as shown. Occasionally a trimming resistor is not required and in such cases the slip packed with the sensor will be marked 'N/R' instead of quoting the value of the resistor supplied.

Figure 1. Typical Response to 20% LEL

7216

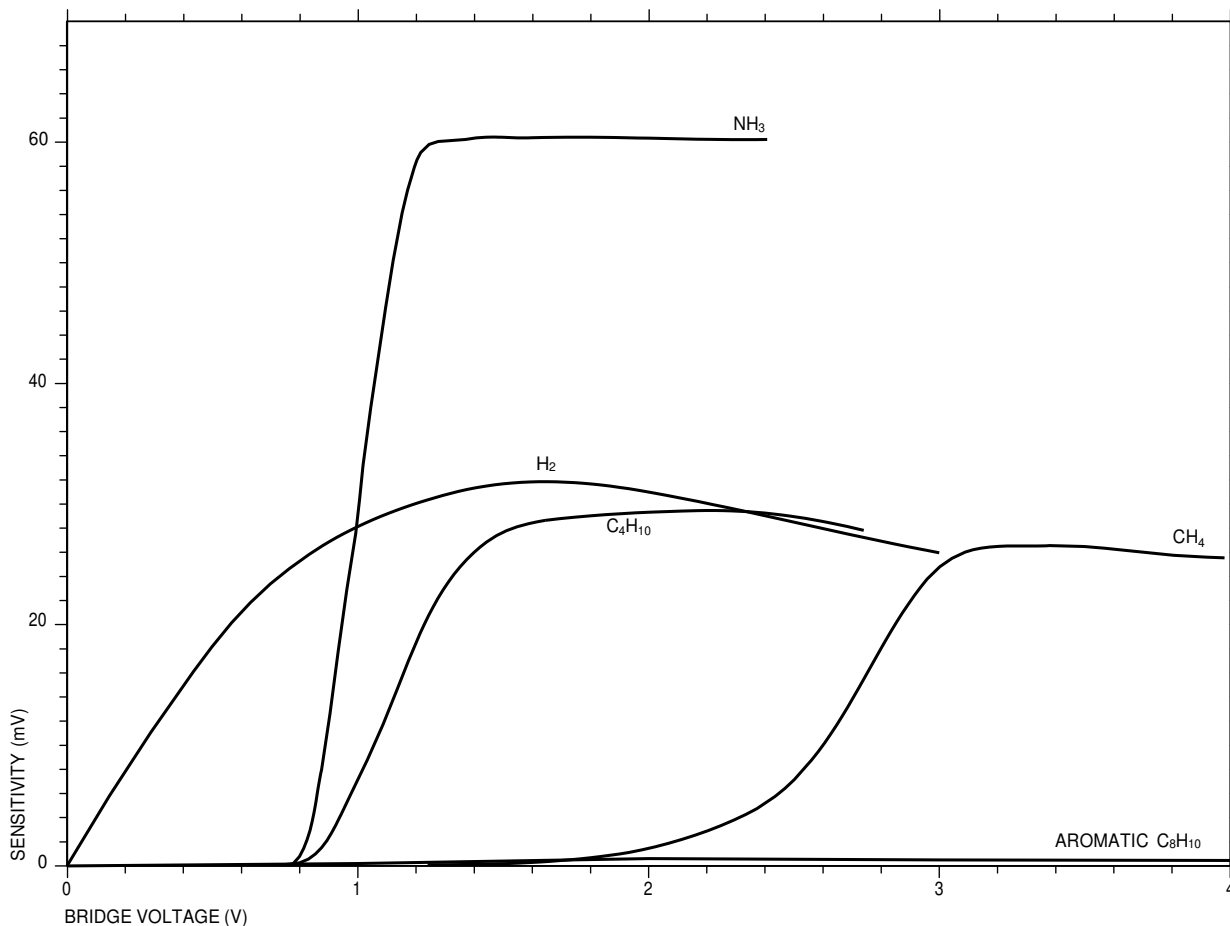

OUTLINE OF DETECTOR ELEMENT

7218

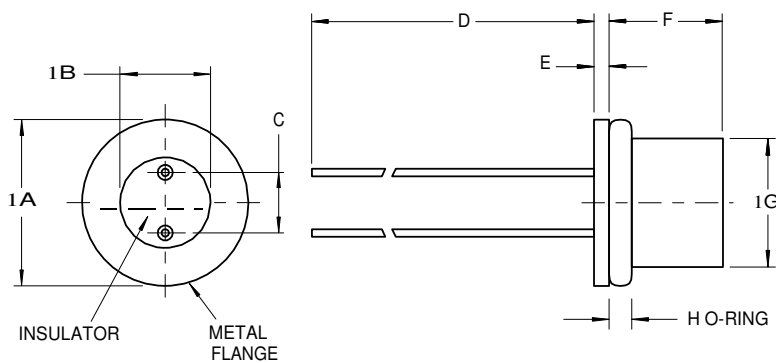

Ref	Millimetres	Inches
A	11.3 max	0.445 max
	10.8 min	0.425 min
B	6.35 max	0.250 max
	5.85 min	0.230 min
C	3.69 max	0.145 max
	3.43 min	0.135 min
D	40.0 min	1.575 min
E	1.0 nom	0.039 nom
F*	6.35 max	0.250 max
	5.33 min	0.210 min
G	8.2 max	0.323 max
H	1.5 nom	0.059 nom

Inch dimensions have been derived from millimetres.

* For the compensator element, dimension F is 7.88 mm (0.310 inches) max, 6.86 mm (0.270 inches) min.

WARNING

To satisfy the requirements of the recognised approval authorities, **SGX Sensortech** recommends that a suitable sintered metal flame arrestor be used with the device to ensure safe operation.