

E	SS	D DECKER
10/17/2007	ECN-81838	

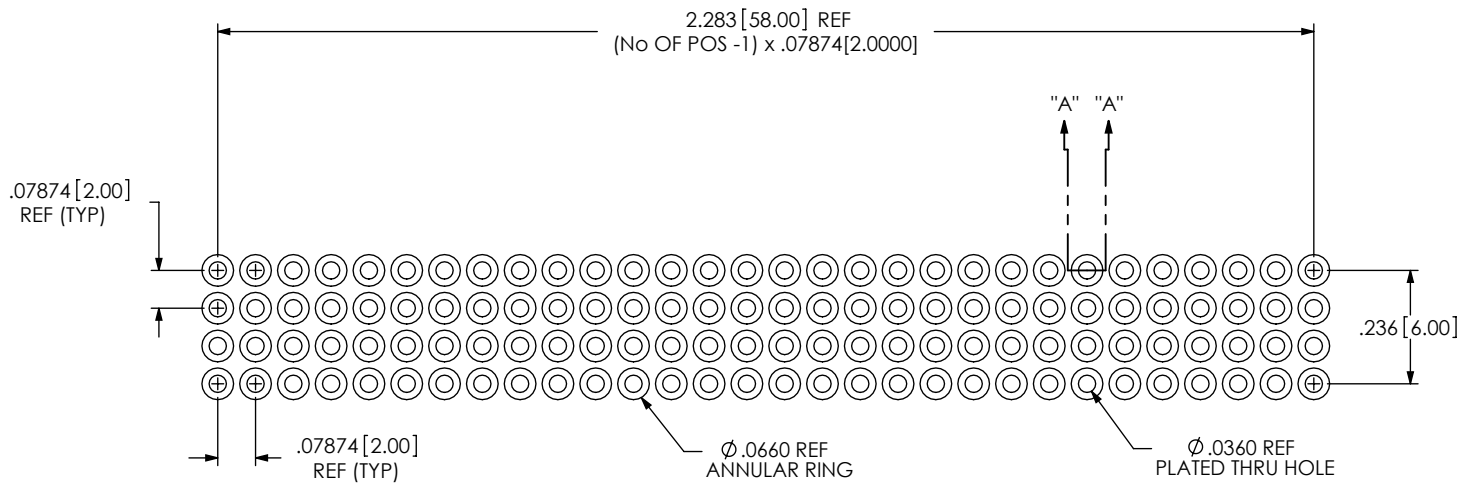

- NOTE:
 1. MAX HARDNESS OF COPPER LAYER: 150 KNOOP.
 2. CONTACT SAMTEC FOR INSERTION TOOLING: P/N S-11297-XX

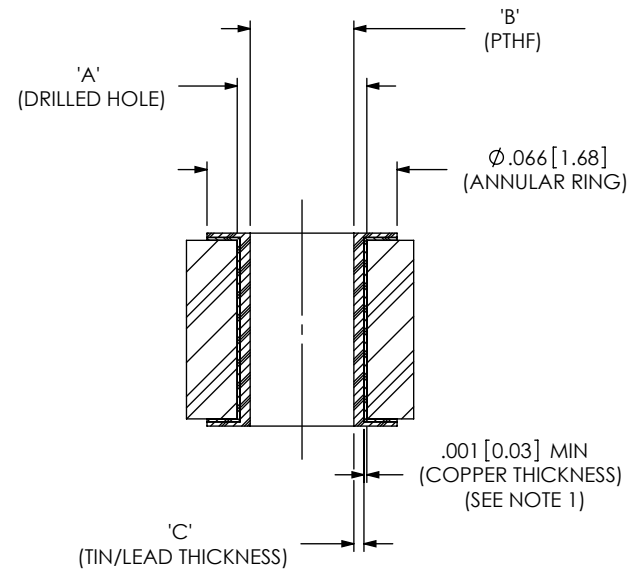

SECTION "A"- "A"

E				
	A	B	C	
E	HASL	0.041	.036±.002	0.005 MAX
	GOLD	0.041	.038±.002	N/A
	SILVER	0.041	.038±.002	N/A
E	TIN	0.041	.038±.002	N/A

PROPRIETARY NOTE
 THIS DOCUMENT CONTAINS INFORMATION CONFIDENTIAL AND PROPRIETARY TO SAMTEC, INC. AND SHALL NOT BE REPRODUCED OR TRANSFERRED TO OTHER DOCUMENTS OR DISCLOSED TO OTHERS OR USED FOR ANY PURPOSE OTHER THAN THAT WHICH IT WAS OBTAINED WITHOUT THE EXPRESSED WRITTEN CONSENT OF SAMTEC, INC.



520 PARK EAST BLVD, NEW ALBANY, IN 47150
 PHONE: 812-944-6733 FAX: 812-948-5047
 e-Mail: info@SAMTEC.com code: 55322