

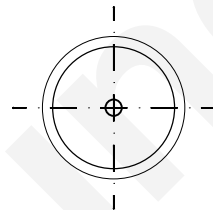

PART NO.	BASE TYPE	DESIGN VOLTS	DESIGN AMPS	MSCD	FILAMENT TYPE	AVERAGE LIFE HOURS	REVISIONS			
							REV #	DESCRIPTION	DATE	APPROVED
3423A	FESTOON CAP (SV8.5-8)	12.0V	0.42±15%	4.0±20%	C-8	500	1	ISSUED	06/02/2014	R.M.
							2	BULB SHAPE REVISION	02/09/2017	R.M.

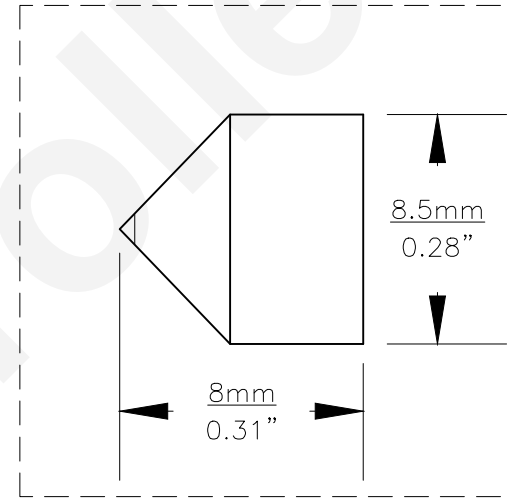
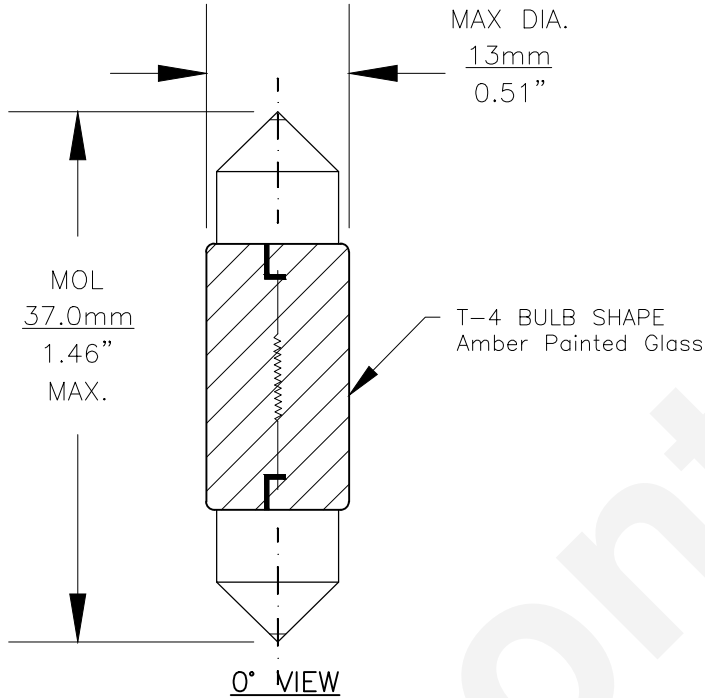

Note: Made according to SAE specifications

UNLESS OTHERWISE SPECIFIED: DIMENSIONS ARE IN INCHES TOLERANCES		CEC INDUSTRIES LTD			
DECIMALS	ANGULAR	599 BOND STREET		LINCOLNSHIRE, IL 60069	
.XX ± .05	± 0.5°				
.XXX ± .010					
FRACTIONAL	± 1/64				
DRAWN ROSE MEDINA	DATE 06/02/2014	TITLE LIGHT BULB NO. 3423A			
CHECKED		SIZE A	FSCM NO.	DWG NO. 3423A	REV 2
DESIGN		SCALE	PLOT SCALE	SHEET 1 OF 1	
MATERIAL		FILE 3423A.pdf	DRAWING NOT TO SCALE		