

TDC1000-GASEVM User's Guide

User's Guide



Literature Number: SNIU026A
March 2015—Revised December 2015

1	General Overview	5
2	TDC1000-GASEVM vs. TDC1000-TDC72000EVM	5
3	EVM Package Contents	5
4	Software	5
5	Setup	6
6	Software Installation	8
	6.1 Graphical User Interface (GUI)	8
7	TDC1000-BSTEVM Setup and Operation	9
	7.1 Connections	9
8	Launching the Software	10
9	Clock Selection	14
	9.1 Steps to Select the CPU Clock	14
10	Possible Excitation Pulses	17
11	Troubleshooting	18
	11.1 Boost converter	18
	11.2 Jumper	18
	11.3 Firmware Upgrade	19
12	TDC1000-GASEVM Board Layout	21
13	TDC1000-GASEVM Schematic	29
14	TDC1000-BSTEVM Board Layout	32
15	BSTEVM Schematic	33
	Revision History	34

List of Figures

1	TDC1000-GASEVM	6
2	TDC1000-BSTEVM Board.....	7
3	TDC1000-7200EVM Installation Directory.....	8
4	TDC1000-BSTEVM Plugged into TDC1000-TDC7200EVM	9
5	SETUP Tab in TDC1000-TDC7200EVM.....	11
6	Top to Bottom: START Pulse, Voltage on VDD Pin of UCC Driver, Voltage Across Connector J1, EN1 Signal on Oscilloscope	12
7	Top to Bottom: TDC1000's START Pulse (Dark Blue), TDC1000's Tx Signal (Light Blue), and the Boosted 30 V of TD1000's Tx Signal (Green)	13
8	Place Jumper on JP6 to Use the CPU Clock.....	14
9	Select CPU-CLK.....	15
10	Clock Options	16
11	Excitation Pulses Chart.....	17
12	Jumper	18
13	Connection Error Pop-up Window	19
14	USB Firmware Upgrade Window.....	20
15	Top Overlay	21
16	Top Solder Mask	22
17	Top Layer.....	23
18	Mid Layer 1.....	24
19	Mid Layer 2.....	25
20	Bottom Layer.....	26
21	Bottom Solder Mask	27
22	Board Dimensions.....	28
23	TDC1000-GASEVM Schematic 1	29
24	TDC1000-GASEVM Schematic 2	30
25	TDC1000-GASEVM Schematic 3	31
26	BSTEVM Layout.....	32
27	TDC1000-BSTEVM	33

List of Tables

1	Jumper.....	18
---	-------------	----

TDC1000-GASEVM and TDC1000-BSTEVM Kit User's Guide

1 General Overview

This user's guide details the use of the TDC1000-GASEVM, which is comprised of two boards. The first board is the main TDC1000-GASEVM, which includes an on-board TDC1000 (ultrasonic analog-front-end), TDC7200 (time-to-digital converter), and MSP430 microcontroller. The purpose of this board is to excite the transducers, receive the returned echo, generate the STOP pulses, and digitize the time-of-flight to the MSP430 for further processing. This main board connects with a separate TDC1000-BSTEVM board (referred to as HV board for the remainder of this document). The purpose of the HV board is to boost the transmit pulses from 3.7V-to-30V to get a better received echo for applications where a higher range is necessary or when the ultrasonic medium is a gas or is exposed to vibration.

2 TDC1000-GASEVM vs. TDC1000-TDC7200EVM

The TDC1000-GASEVM is compatible with the Firmware and GUI of the TDC1000-TDC7200EVM since all the components are the same. However, the TDC1000-GASEVM has the following component changes to facilitate rapid evaluation for water/gas flow applications.

1. The TDC1000-GASEVM has been designed for Gas Flow applications. The passive components that determine the first order filter of the Rx signal path have been tuned for frequencies between 58 kHz to 300 KHz.
2. The resistors connecting the TX2/RX1 and TX1/RX2 channel have been removed to enable the TDC1000-GASEVM to be used with the TDC1000-BSTEVM. When resistors have been removed, the transmitting pulses increase from 3.7 V to 30 V.

3 EVM Package Contents

The TDC1000-GASEVM evaluation kit contains the following:

- On board TDC1000 (ultrasonic analog-front-end) and TDC7200 (time-to-digital converter)
- On board MSP430 microcontroller
- USB Mini-B to USB-A plug cable

The TDC1000-BSTEVM kit contains the following:

- On board LM2733XMF boost converter
- On board UCC27531 Gate drivers
- Connectors to plug into the TDC1000-GASEVM or TDC1000-TDC7200EVM

4 Software

The firmware and GUI is the same as the TDC1000-TDC7200 EVM. For detail information about the GUI and troubleshooting the software, see the TDC1000-TDC7200EVM User's Guide [SNIU021](#).

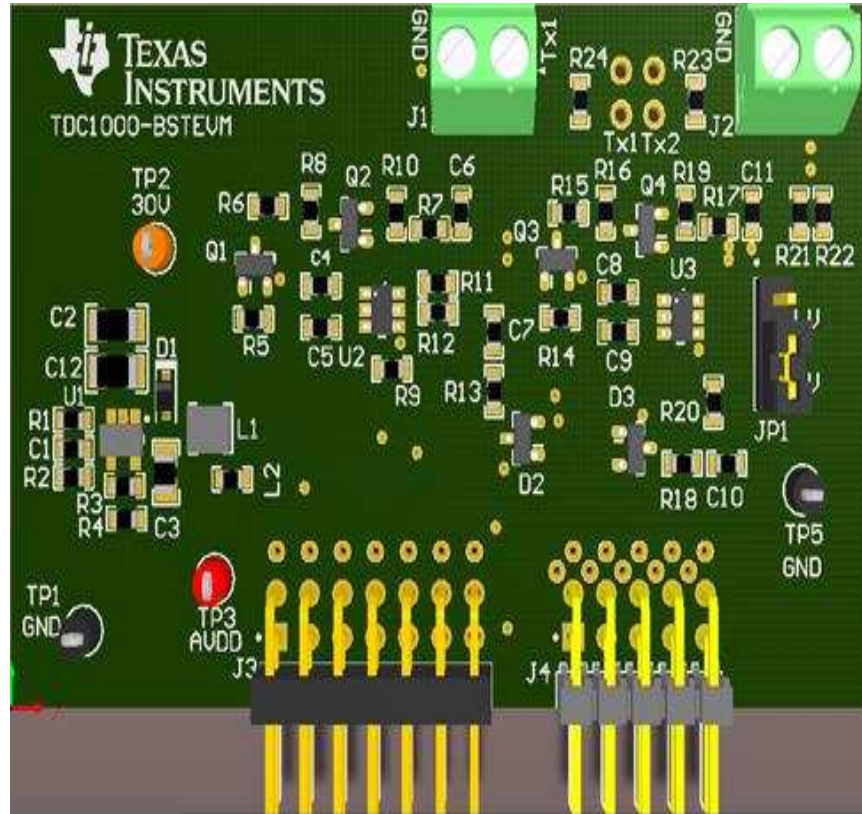

Figure 2. TDC1000-BSTEVM Board

6 Software Installation

6.1 Graphical User Interface (GUI)

Installing the TDC1000-GASEVM GUI software:

1. Download the GUI <http://www.ti.com/product/TDC1000/toolssoftware>
2. Unzip the downloaded file into a known directory and run it
3. Follow the pop-up screen instructions. Click “Next” to install the software.

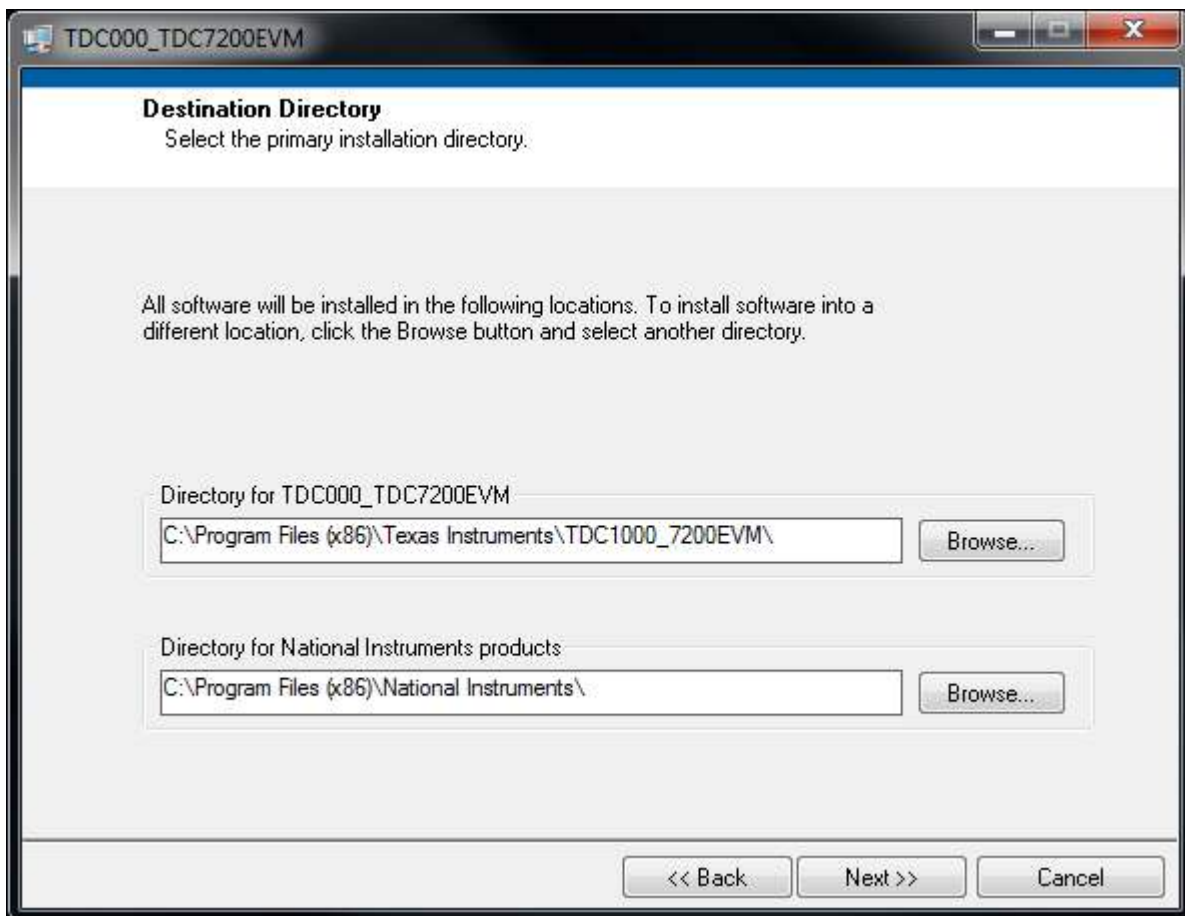

Figure 3. TDC1000-7200EVM Installation Directory

4. When the installation is done, click “Finish”.

7 TDC1000-BSTEVM Setup and Operation

7.1 Connections

1. Connect the USB cable (J2) from the TDC1000-GASEVM to the PC.
2. Plug the TDC1000-BSTEVM (HV board) into the TDC1000-GASEVM (see [Figure 4](#)).
3. Attach the transducer wires to the connectors J1 and J2 on the HV board.

On the TDC1000-GASEVM, make sure the following jumpers are in place.

1. JP1: TDC7200 - connect pin 1 to pin 2 (via a jumper)
2. JP2: CPU - connect pin 1 to pin 2 (via a jumper)
3. JP3: TDC1000 - connect pin 1 to pin 2
4. JP4: VIO - connect pin 1 to pin 2
5. JP5: Trigger - connect pin 2 to pin 3
6. JP6: CLOCK - connect pin 5 to pin 6

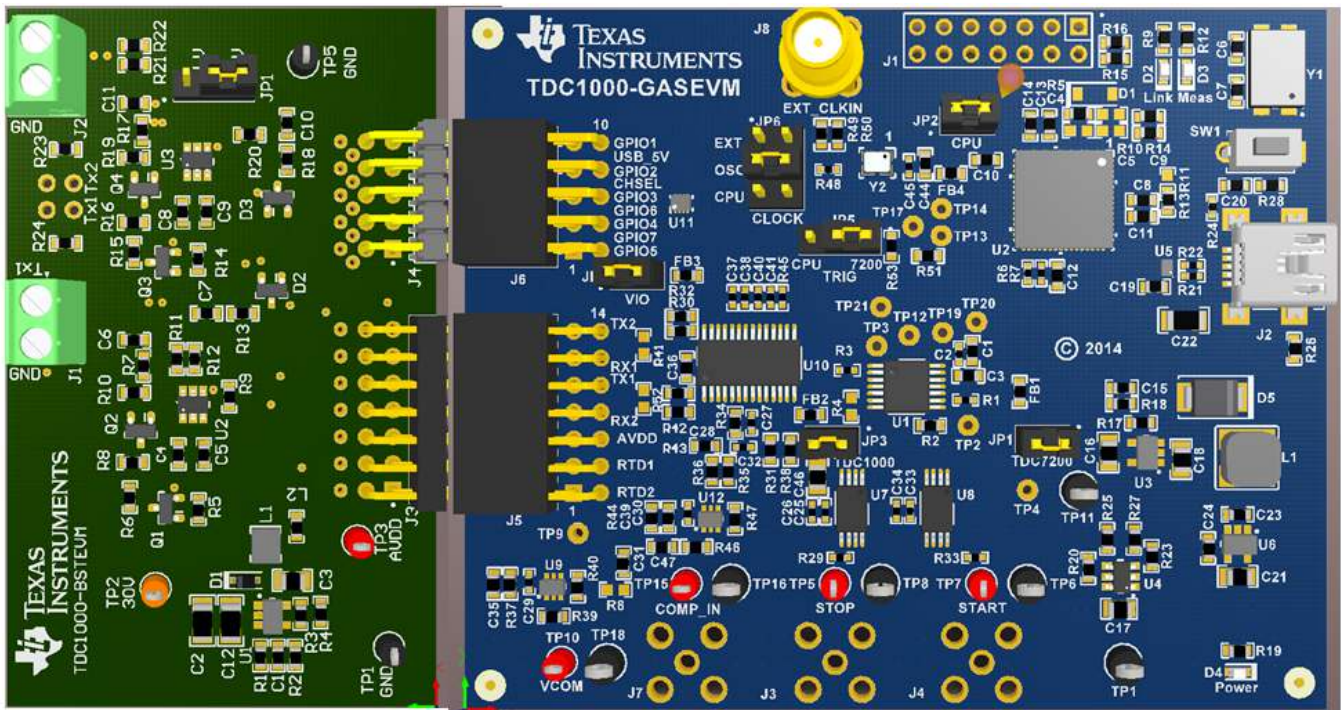

Figure 4. TDC1000-BSTEVM Plugged into TDC1000-TDC7200EVM

8 Launching the Software

1. The TDC1000_TDC7200EVM GUI software can be run by clicking on **Start >> All Programs >> Texas Instruments >> TDC1000_7200**.
2. See TDC100-TDC7200EVM_Users_Manual ([SNIA020](#)) on how to use the GUI
3. **When using the HV board:** Go to the "SETUP" tab on the TDC1000-7200EVM GUI and select "TDC1000-HV Boost Power Enable" to enable the 30V boost supply. The supply will remain on constantly (Always ON) unless a different time period is selected via the pulldown box. The capacity to reduce the Boost power supply active time is to enable very low power applications testing so the BOOST supply is only active during the measurement cycle time. Next make sure to select either "TDC1000-HV Driver EN1" or "TDC1000-HV Driver EN2" -- or both of them by checking the respective box.
 - (a) Select an "EN period (us)" in μs . This is the time the EN will stay HIGH after the START pulse of the EVM. EN will go high about 30 μs before START to ensure that the driver ICs on the HV interface board are powered up in time for the first Tx pulses. Example: If you choose an EN period of 40 μs (default = 30 μs), you will see a EN pulse with the length of 70 μs , because it consists of the constant 30 μs before the START signal plus whatever you choose for EN period.
 - (b) A longer EN period can be used to dampen the oscillation of the ultrasonic transducers. After the last Tx pulse, the output of the driver IC will be pulled to ground via the 110- Ω resistor that is on the board until the voltage on the VDD pin drops below about 3 V.
4. You can set the "EN period" for EN1 and EN2 separately, but whichever is higher will be applied to BOTH enables if EN1 and EN2 are checked.
5. If you choose to use one channel with 5V pulses and the other with 30V, you can bypass the HV driver of Channel 2. Make sure to uncheck the box "TDC1000-HV Driver EN2" in the GUI and to also place the jumper JP1 on the HV board to "LV" for low voltage.

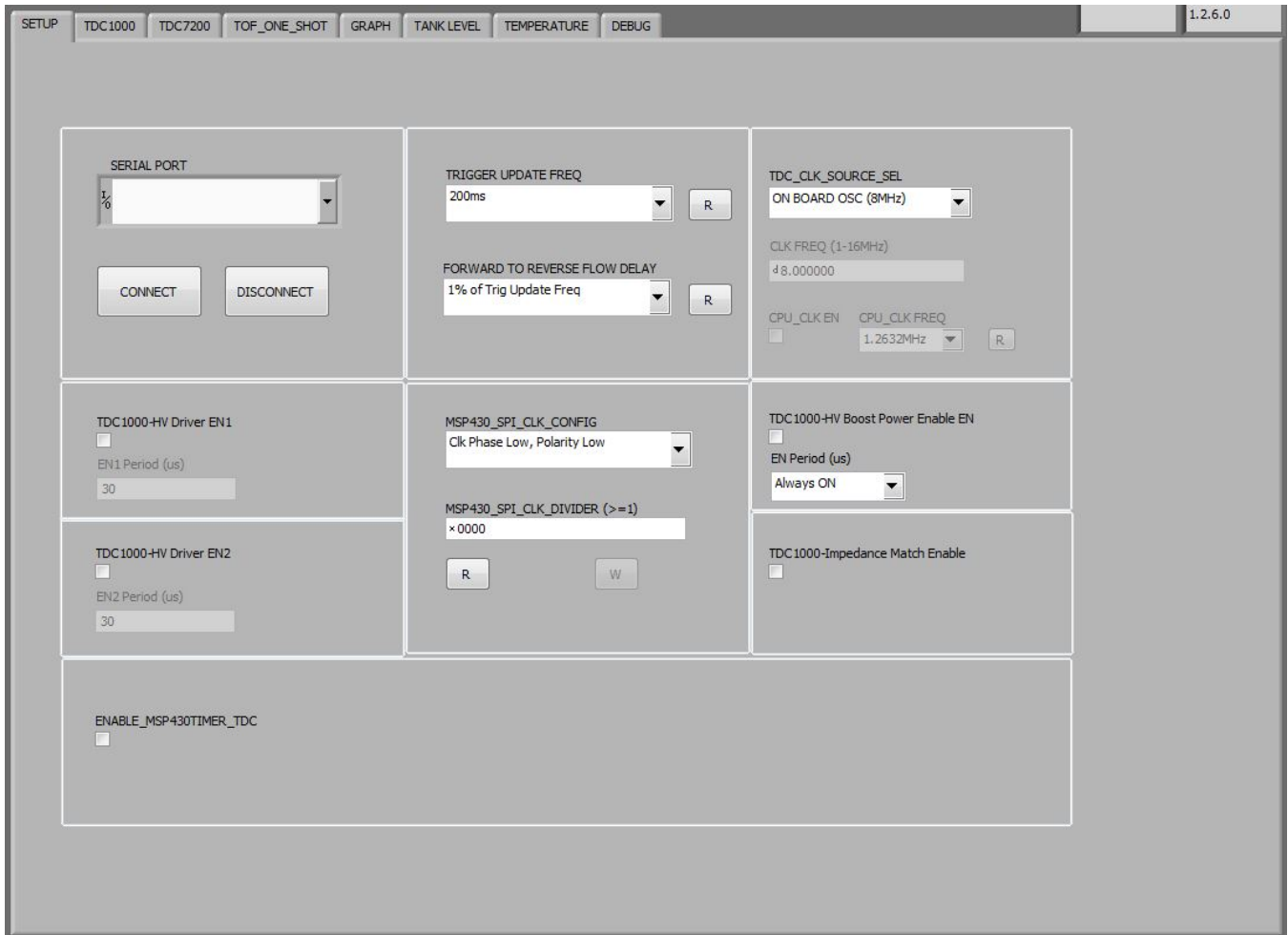
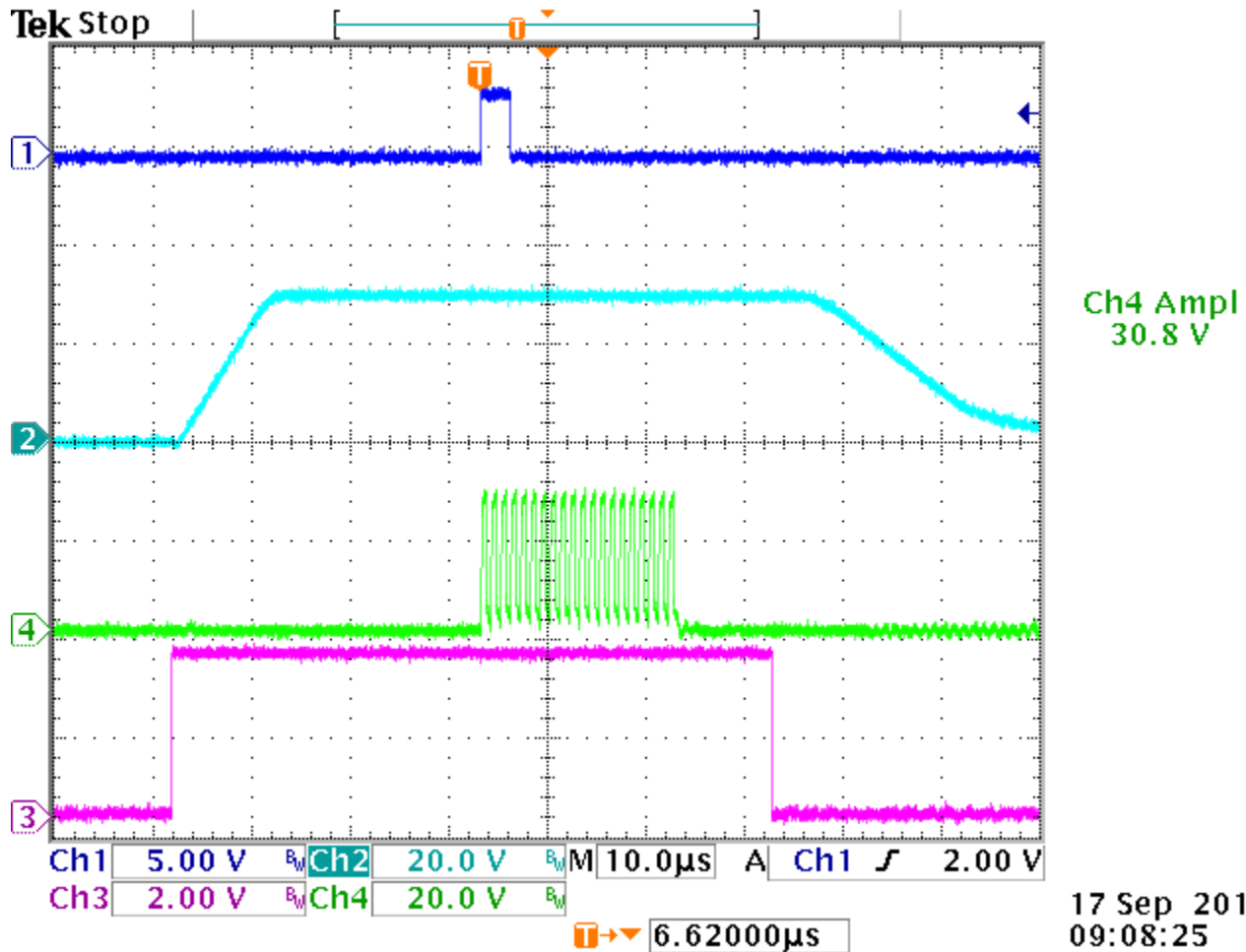

Figure 5. SETUP Tab in TDC1000-TDC7200EVM



**Figure 6. Top to Bottom:
START Pulse,
Voltage on VDD Pin of UCC Driver,
Voltage Across Connector J1,
EN1 Signal on Oscilloscope**

6. Observe the following signals: TDC1000's START (dark blue) on the TDC1000-GASEVM, VDD of driver IC U2(light blue) on the HV board, transmit pulses on transducer connector J1 (green) and EN1 (pink) signals on the oscilloscope as shown in [Figure 6](#). This shows that the VDD of the driver is turned on in time and long enough for this number of pulses. If the last pulses are reduced in amplitude, increase EN period in the "SETUP" tab of the GUI.
7. EN signal should go high about 30µs before START goes high.
8. Observe Tx pulses and voltage at the output of the high voltage drivers as shown in [Figure 7](#). Tx and transducer voltage at connectors J1/2 should be in phase. Tx should have an amplitude of 3.7Vpk-pk and transducer voltage 30Vpk-pk.

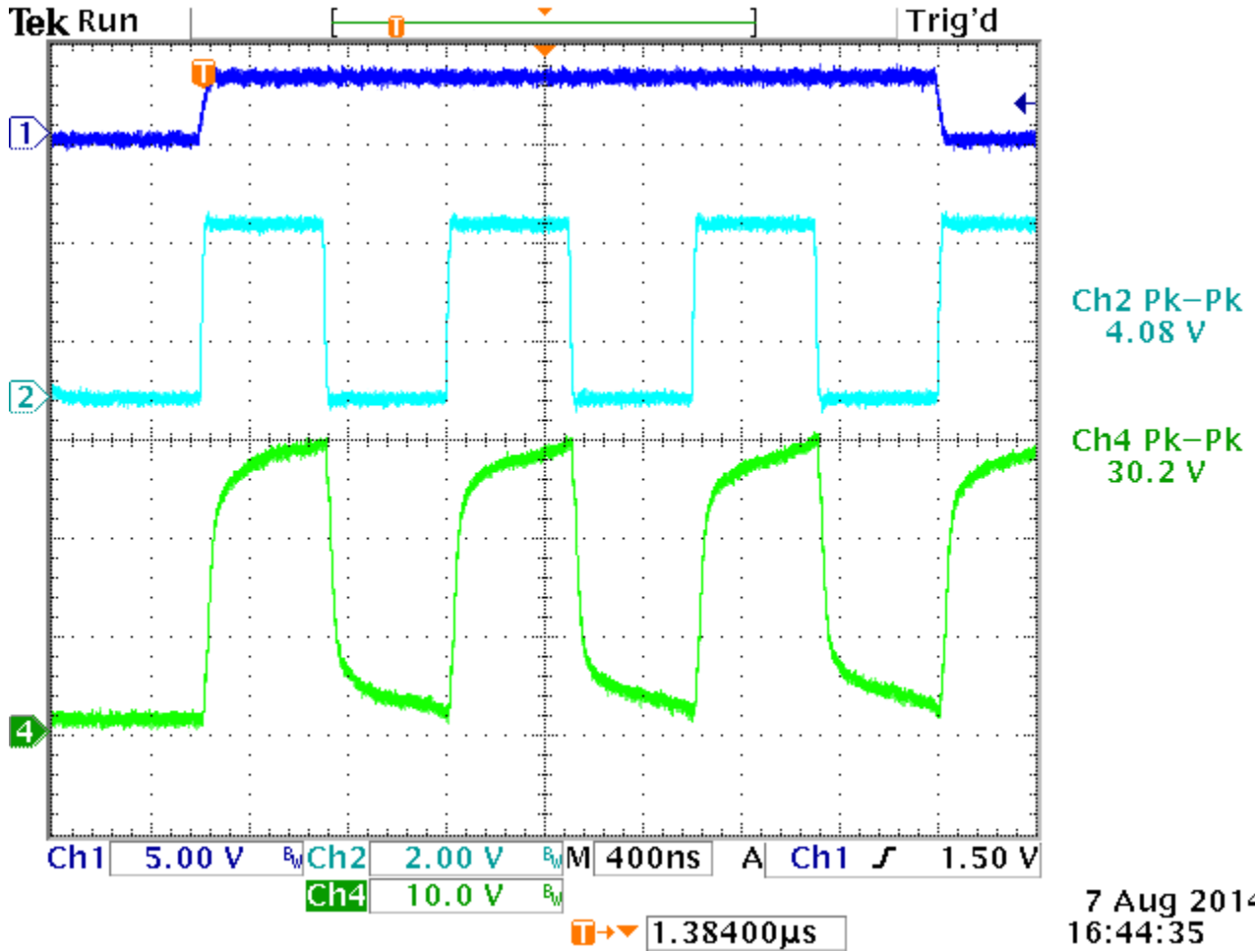

Figure 7. Top to Bottom:
TDC1000's START Pulse (Dark Blue),
TDC1000's Tx Signal (Light Blue),
and the Boosted 30 V of TD1000's Tx Signal (Green)

9 Clock Selection

In order to excite the transducer with its resonant frequency and to achieve the maximum energy transfer and therefore generate a big echo, the EVM allows you to apply the external clock, use the onboard oscillator, or to use the CPU clock.

For gas flow applications, we recommend using the CPU clock. The steps to select the CPU clock can be seen in the following subsections.

9.1 Steps to Select the CPU Clock

1. On the TDC1000-GASEVM, place the JP6 Jumper on the CPU position

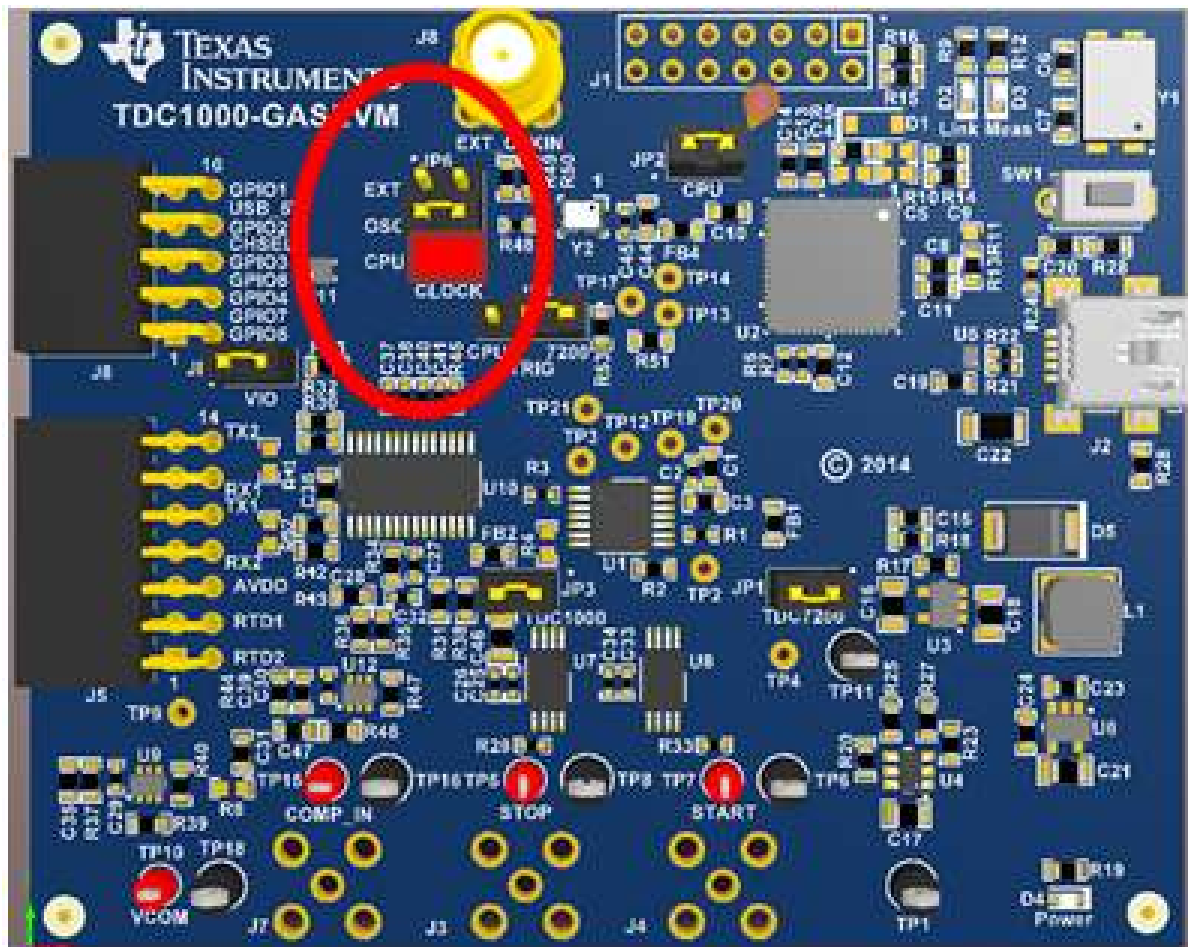

Figure 8. Place Jumper on JP6 to Use the CPU Clock

2. Select CPU_CLK on the SETUP tap of the GUI. A message will pop up. Click "OK".

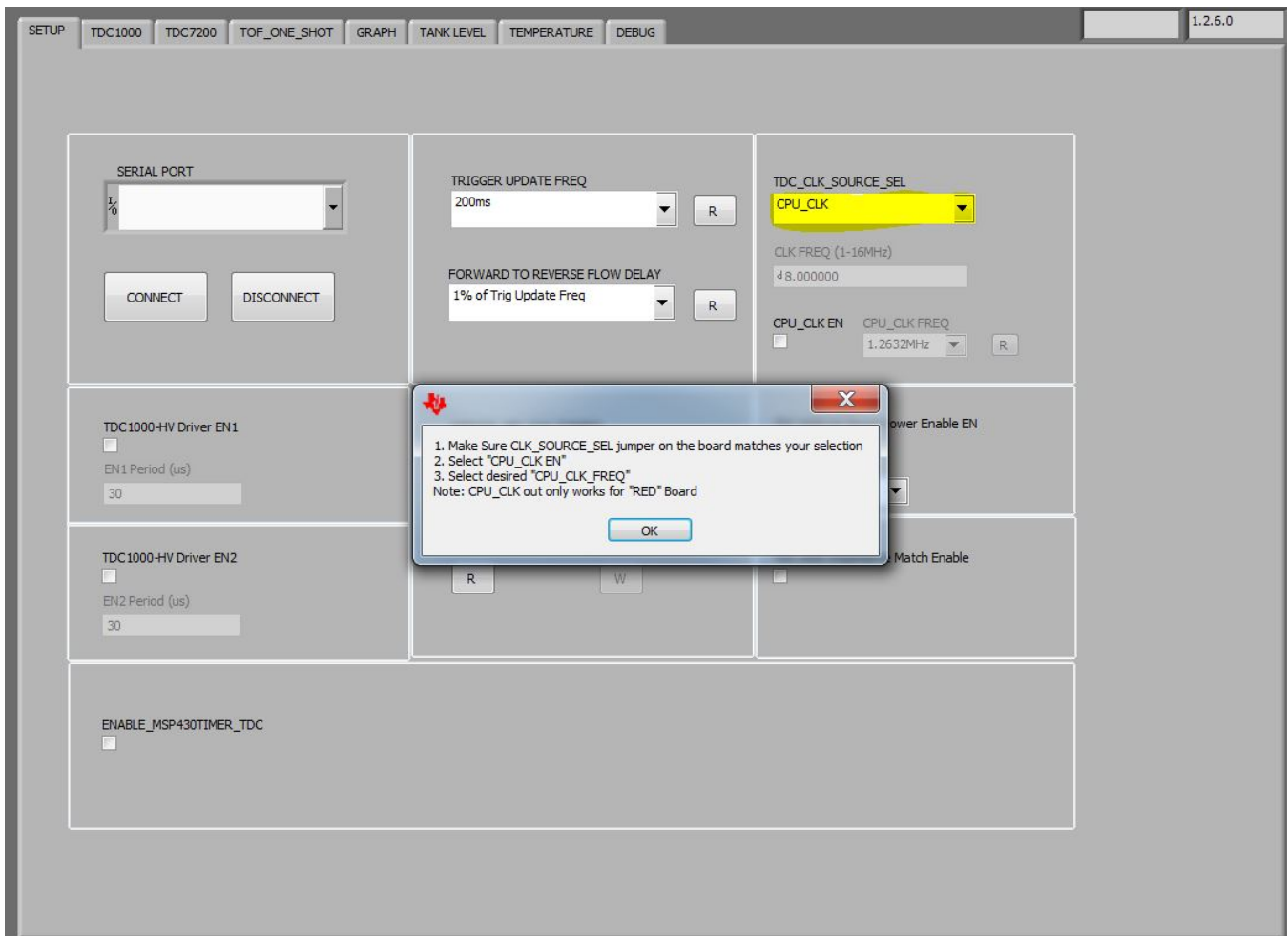

Figure 9. Select CPU-CLK

3. Check the CPU-CLK EN box and Select desired frequency from the drop down menu.

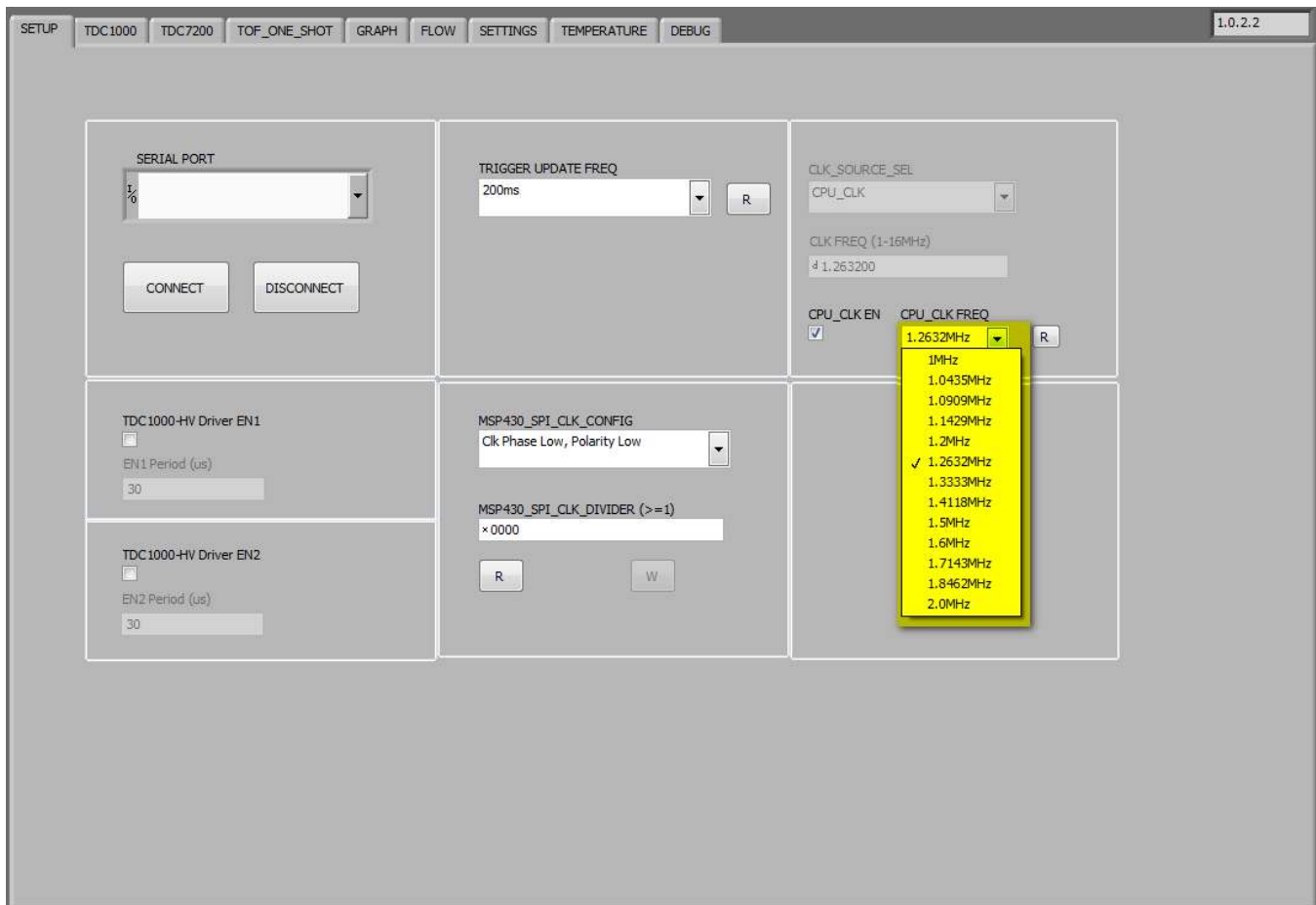

Figure 10. Clock Options

4. In the GUI and on the TDC1000 tab, select a clock divider from the TX_FREQ_DIV register. Note the transducer's resonant frequency = (external clock) / (TX_FREQ_DIV). For example, if the transducer's resonant frequency is 500kHz, and a CPU clock of 2MHz is chosen, then the TX_FREQ_DIV needs to be 4. [Figure 11](#) shows possible excitation pulses using the CPU clock or on-board oscillator of 8MHz.

10 Possible Excitation Pulses

	TX-Frequency Division	2	4	8	16	32	64	128	256
On Board Oscillator	8,000,000	4,000,000	2,000,000	1,000,000	500,000	250,000	125,000	62,500	31,250
CPU Clock (Hz)	1,000,000	500,000	250,000	125,000	62,500	31,250	15,625	7,813	3,906
	1,043,500	521,750	260,875	130,438	65,219	32,609	16,305	8,152	4,076
	1,090,900	545,450	272,725	136,363	68,181	34,091	17,045	8,523	4,261
	1,142,900	571,450	285,725	142,863	71,431	35,716	17,858	8,929	4,464
	1,200,000	600,000	300,000	150,000	75,000	37,500	18,750	9,375	4,688
	1,263,200	631,600	315,800	157,900	78,950	39,475	19,738	9,869	4,934
	1,333,300	666,650	333,325	166,663	83,331	41,666	20,833	10,416	5,208
	1,411,800	705,900	352,950	176,475	88,238	44,119	22,059	11,030	5,515
	1,500,000	750,000	375,000	187,500	93,750	46,875	23,438	11,719	5,859
	1,600,000	800,000	400,000	200,000	100,000	50,000	25,000	12,500	6,250
	1,714,300	857,150	428,575	214,288	107,144	53,572	26,786	13,393	6,696
	1,846,200	923,100	461,550	230,775	115,388	57,694	28,847	14,423	7,212
	2,000,000	1,000,000	500,000	250,000	125,000	62,500	31,250	15,625	7,813

Figure 11. Excitation Pulses Chart

11 Troubleshooting

11.1 Boost converter

The DC/DC converter on the HV board is a LM2733X 1.6 MHz boost converter with integrated switch. Test point TP2 should show a voltage of 30 V. If this is not the case, check if TP3 shows the required input voltage of 5 V.

11.2 Jumper

Table 1. Jumper

JUMPERS	DESCRIPTION
JP1	Tx2 voltage selector: bypass HV driver when placed in "LV" position

For default operation (use high voltage for both channels), place jumper on the following:

1. JP1.P2 and JP1.P3 – HV

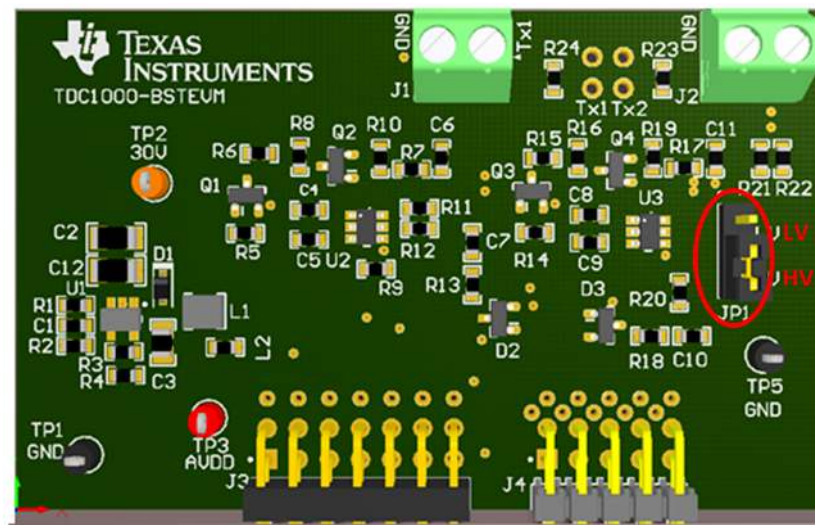

Figure 12. Jumper

When placing the jumper in LV position (on pins 1 and 2), "TDC1000-HV Driver EN2" should be unchecked in the GUI. Otherwise the UCC27531 will pull its output to ground.

11.3 Firmware Upgrade

Note: This section is only necessary if the firmware needs to be changed. The TDC1000-TDC7200EVM comes pre-loaded with firmware already. The HV board needs firmware TDC1000_7200_FW-v1.16-1MHz or newer.

To change the firmware, complete the following steps:

1. Connect the TDC1000-TDC7200EVM to a PC.
2. Open the TDC1000-7200EVM GUI then go to the “DEBUG” tab. Press “OK” if a connection error window pops up. Click on the Update Firmware button.

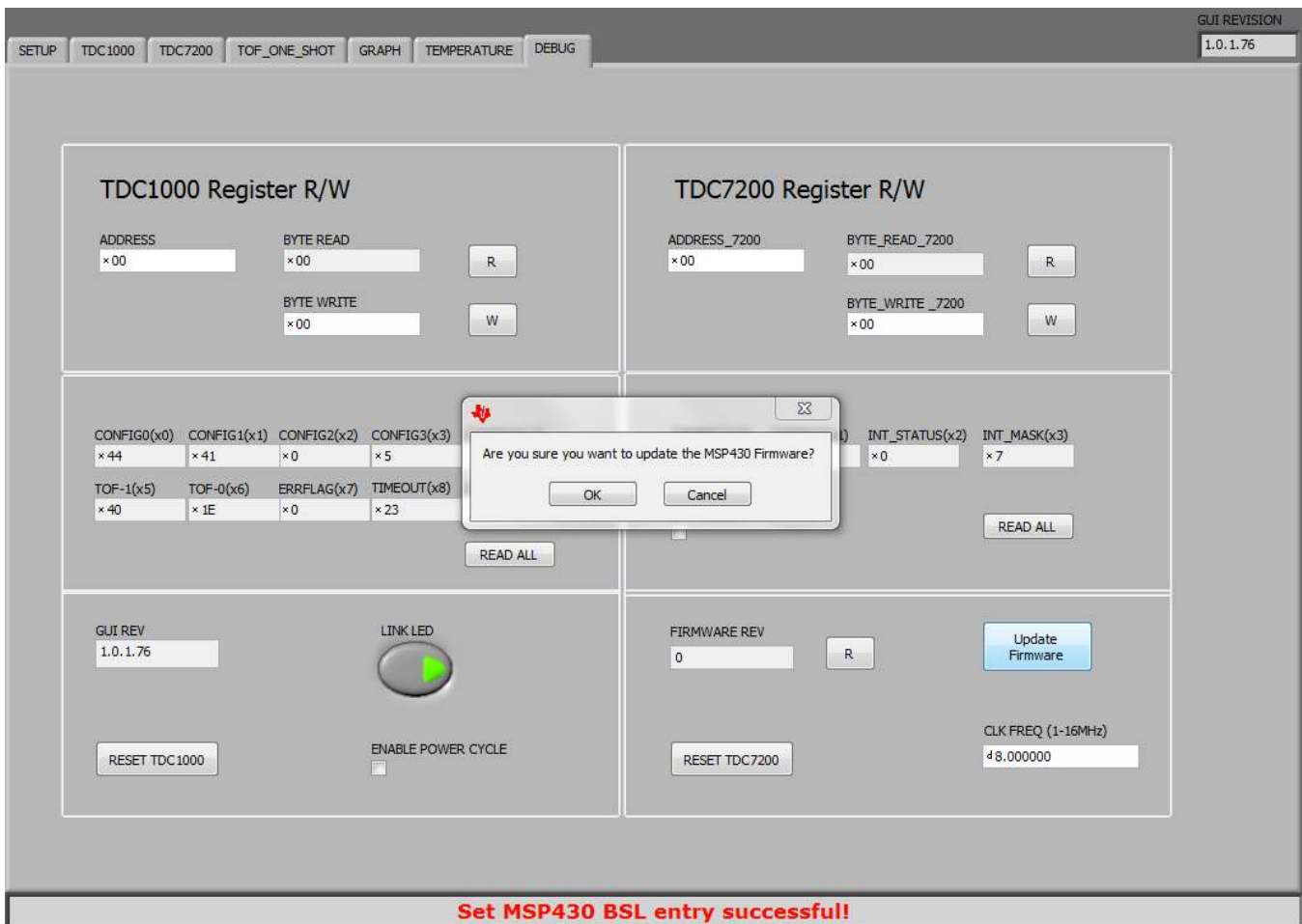

Figure 13. Connection Error Pop-up Window

3. The MSP430 USB Firmware Upgrade windows will pop up. Click “Next” to proceed on the first prompt. Read and accept the license agreement and click “Next” to continue.

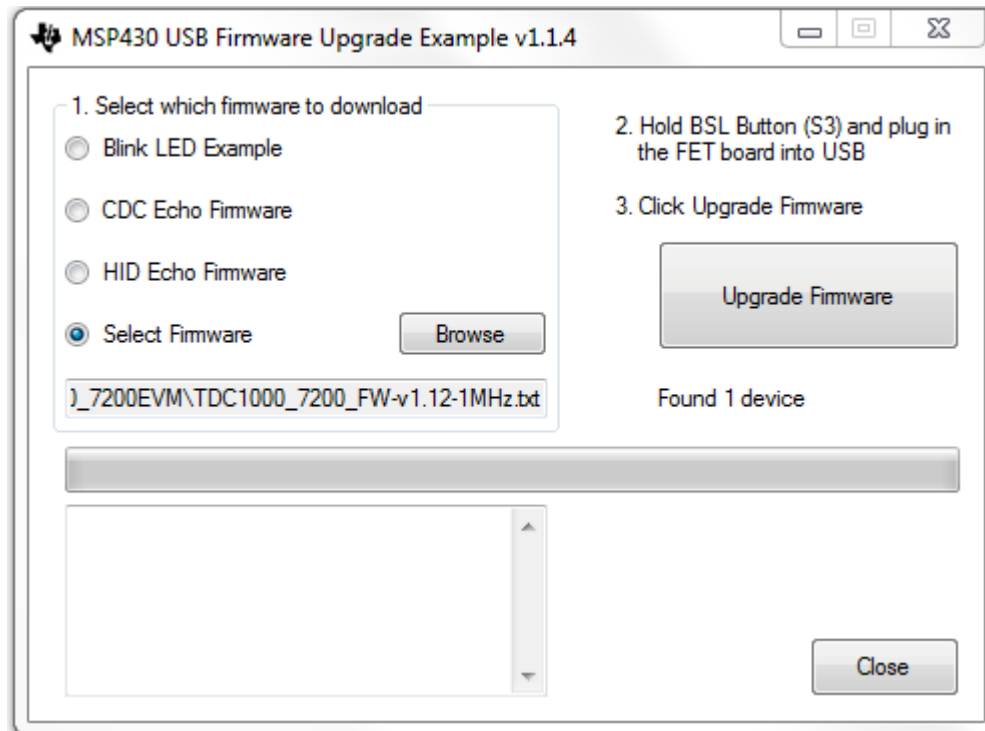

Figure 14. USB Firmware Upgrade Window

1. Disconnect and reconnect the LaunchPad to PC while holding the BSL button down.
2. Select the Select Firmware button and browse to the firmware file.
3. Click on the Upgrade Firmware button to program the EVM. Close the application when done and restart the TDC1000_7200EVM GUI.

12 TDC1000-GASEVM Board Layout

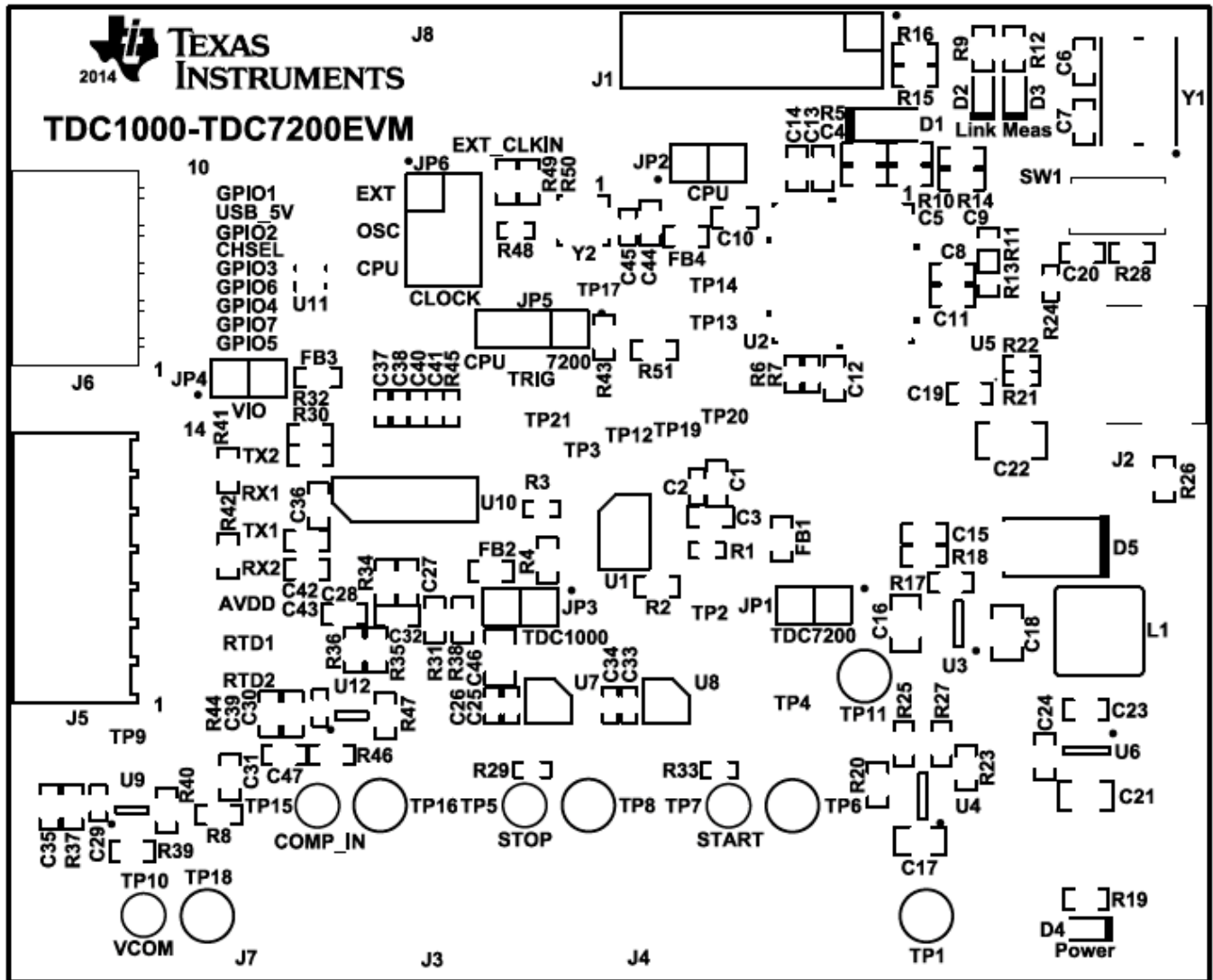

Figure 15. Top Overlay

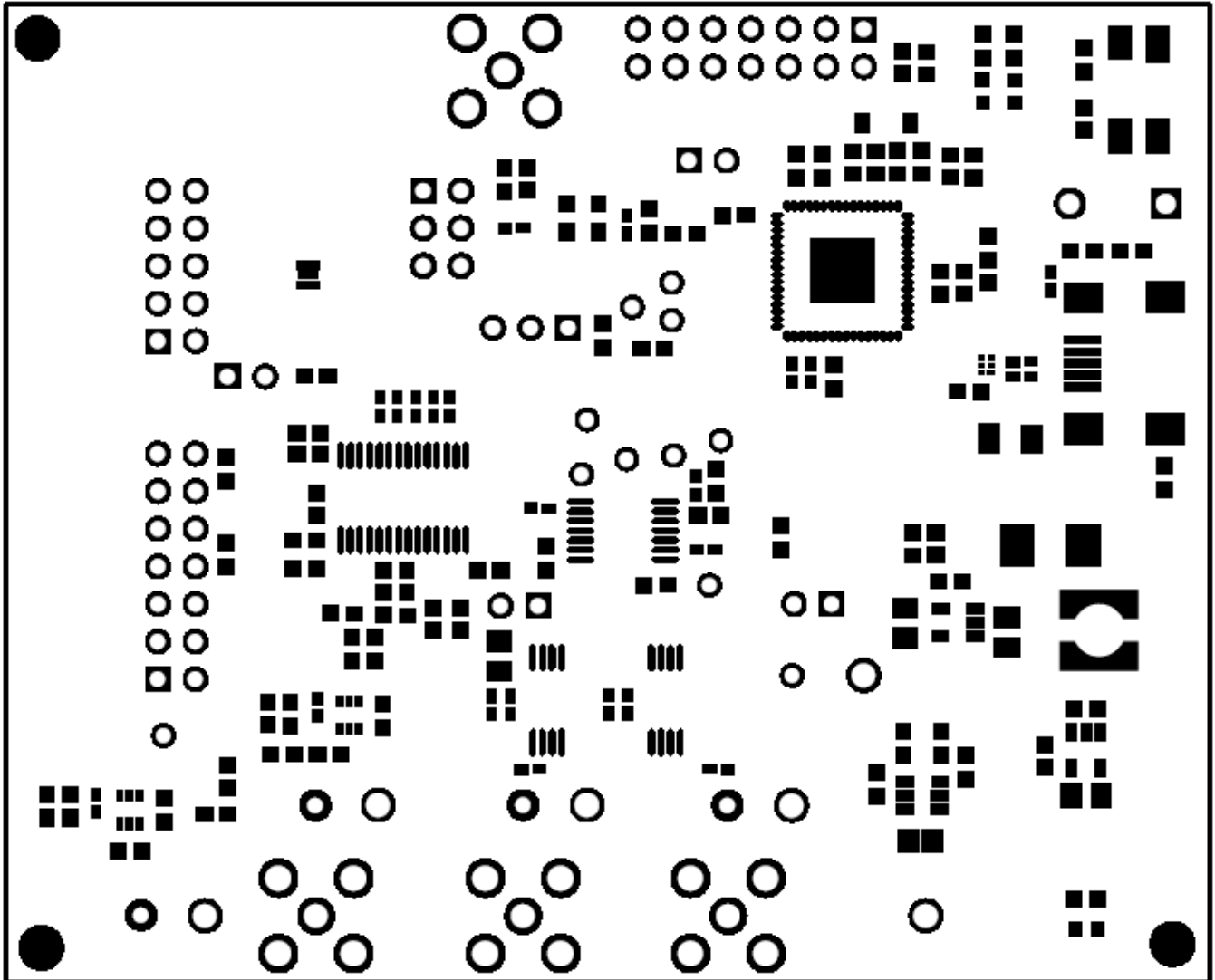

Figure 16. Top Solder Mask

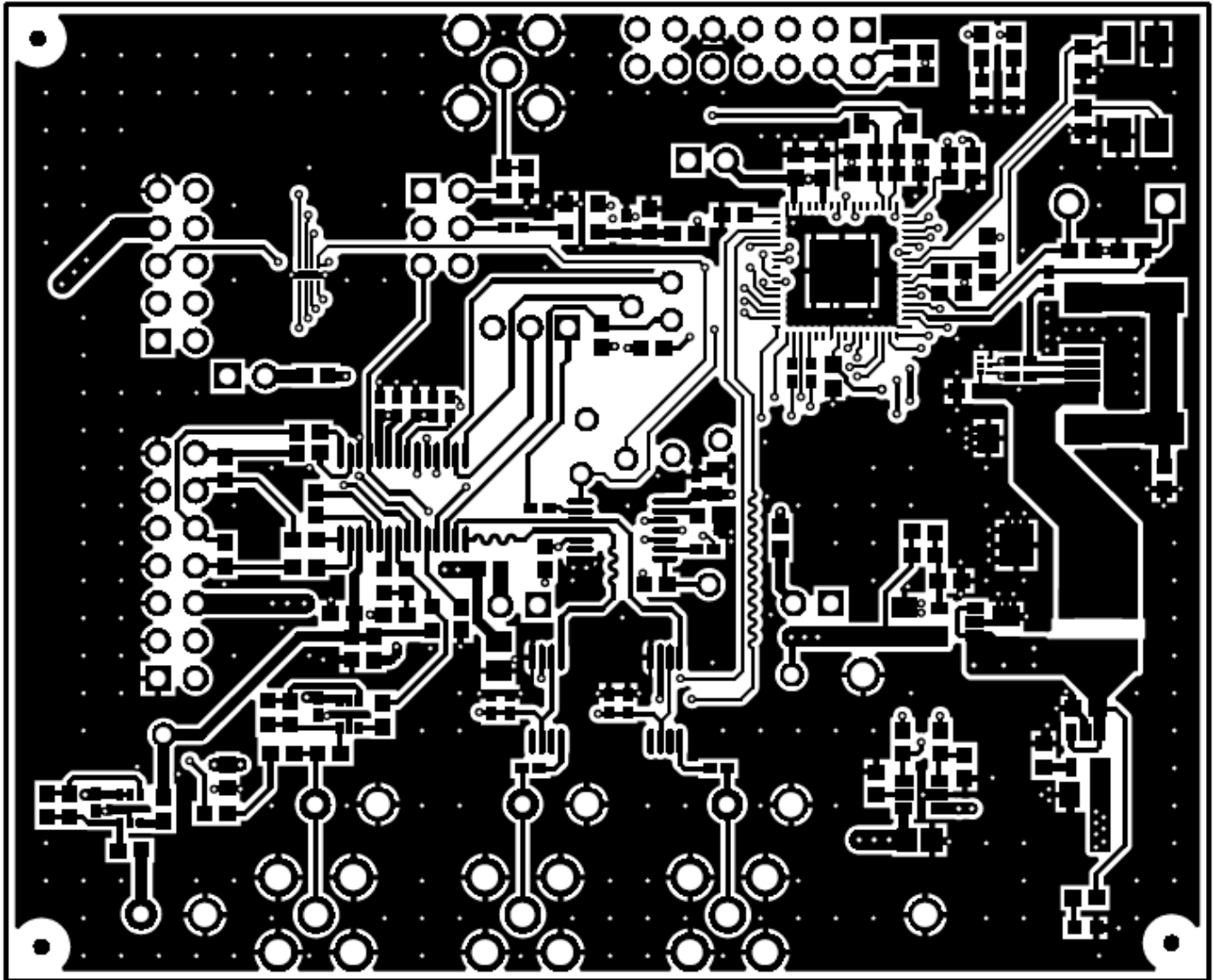

Figure 17. Top Layer

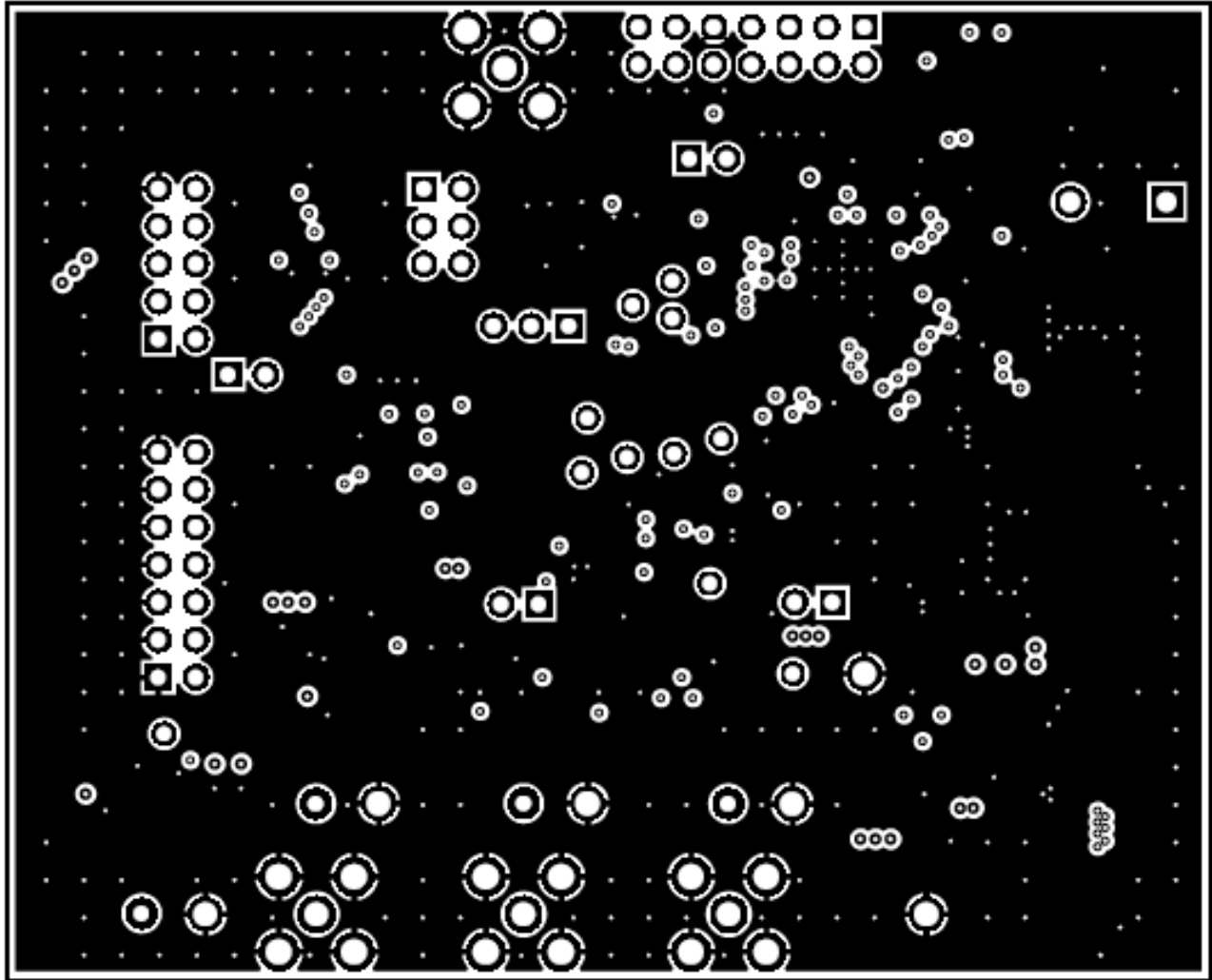

Figure 18. Mid Layer 1

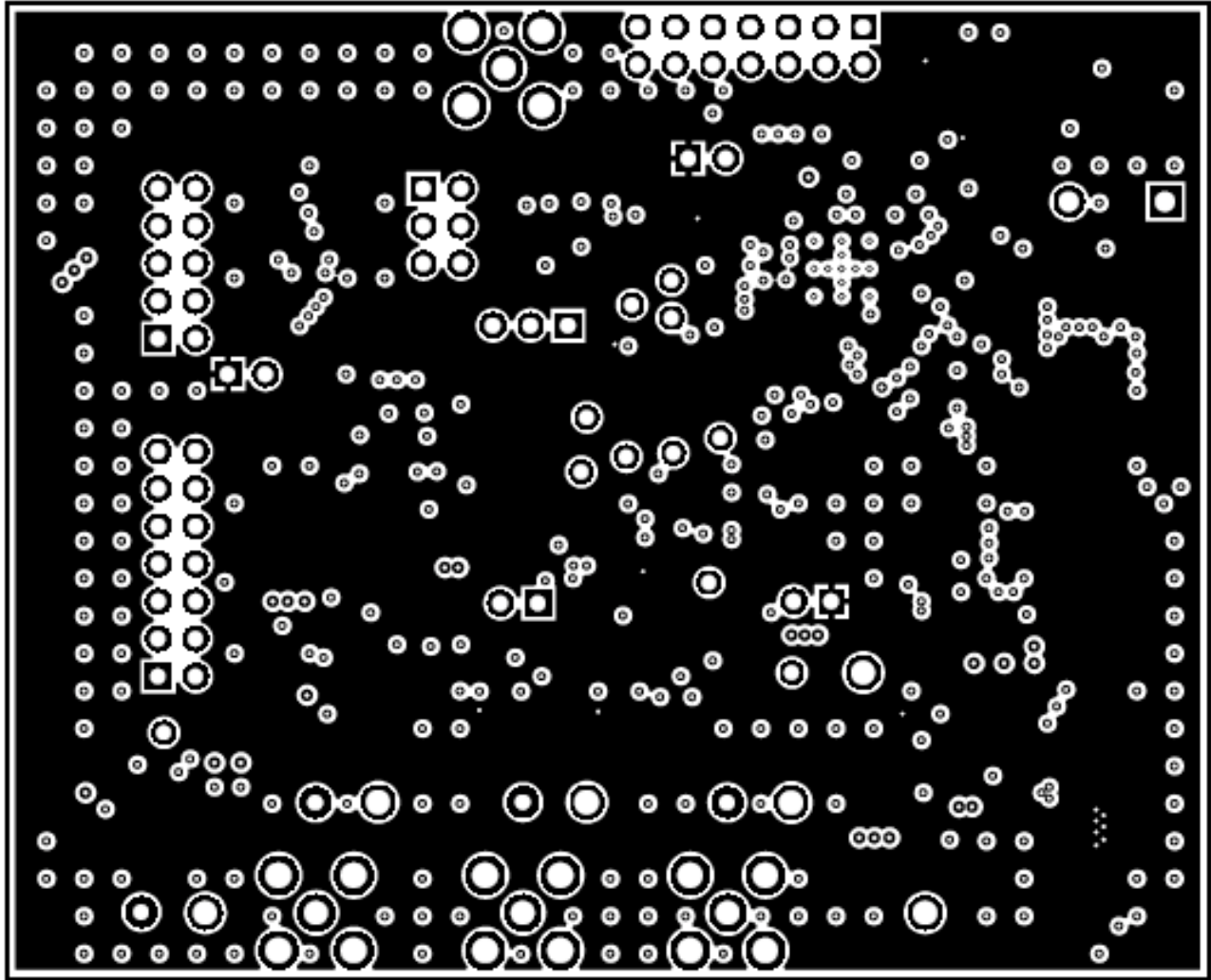

Figure 19. Mid Layer 2

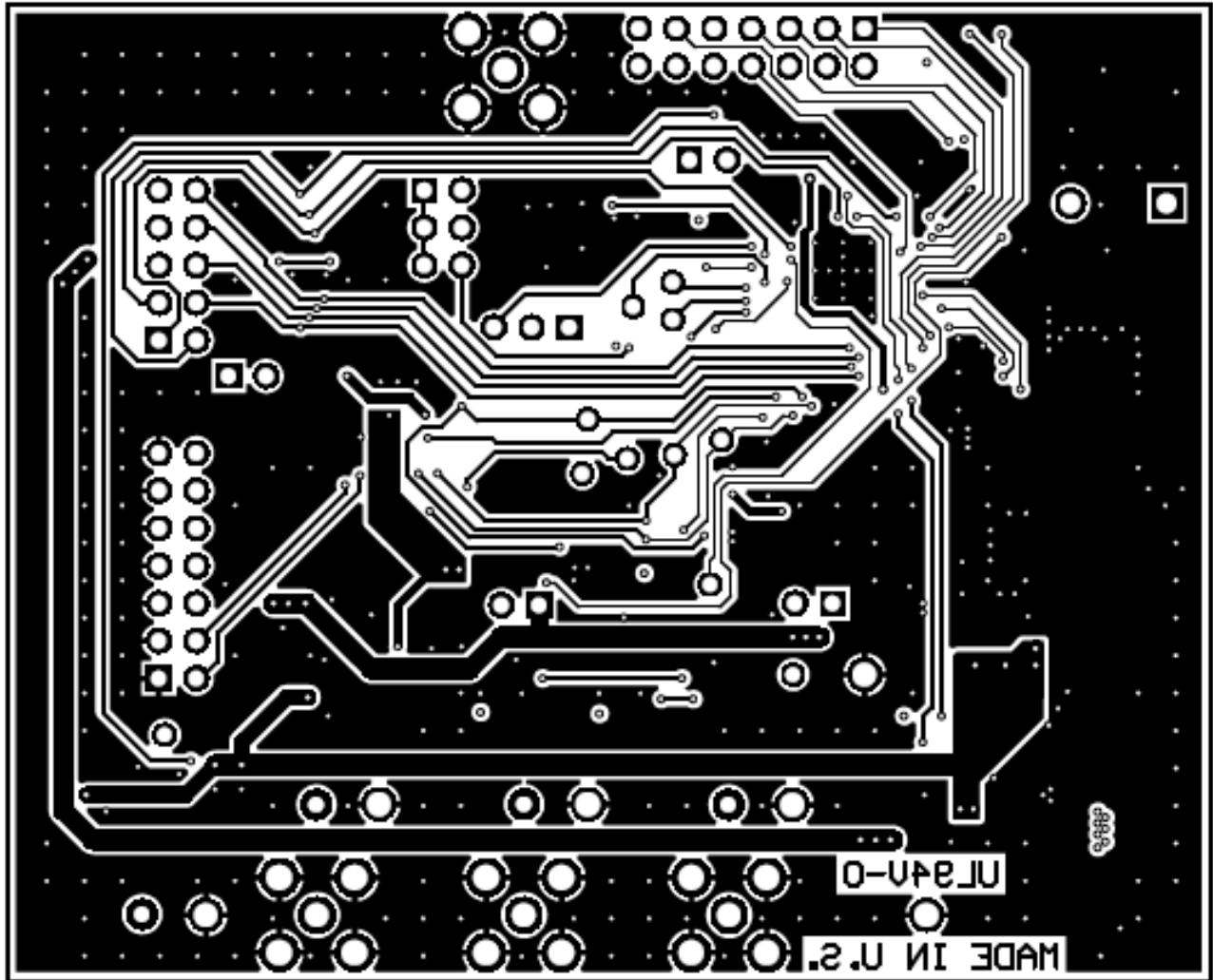

Figure 20. Bottom Layer

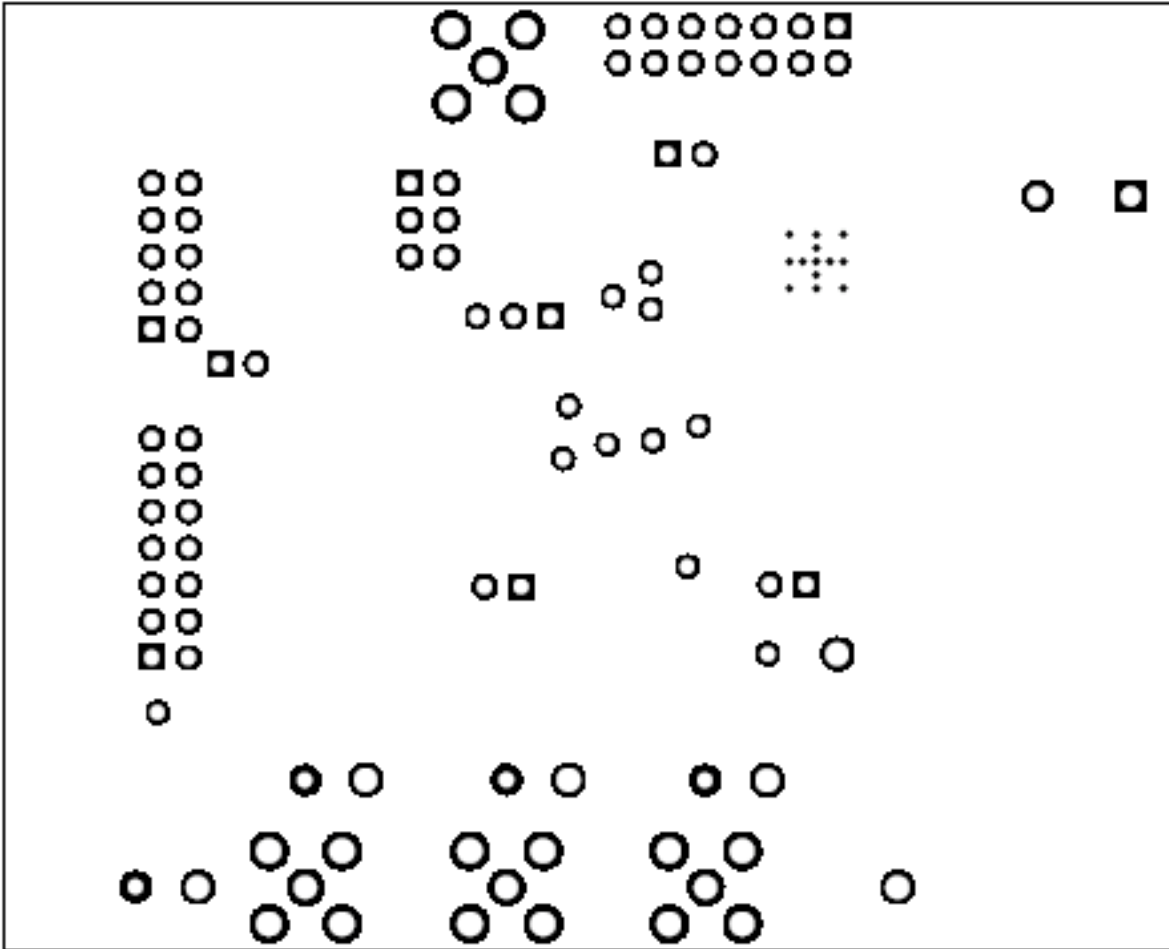

Figure 21. Bottom Solder Mask

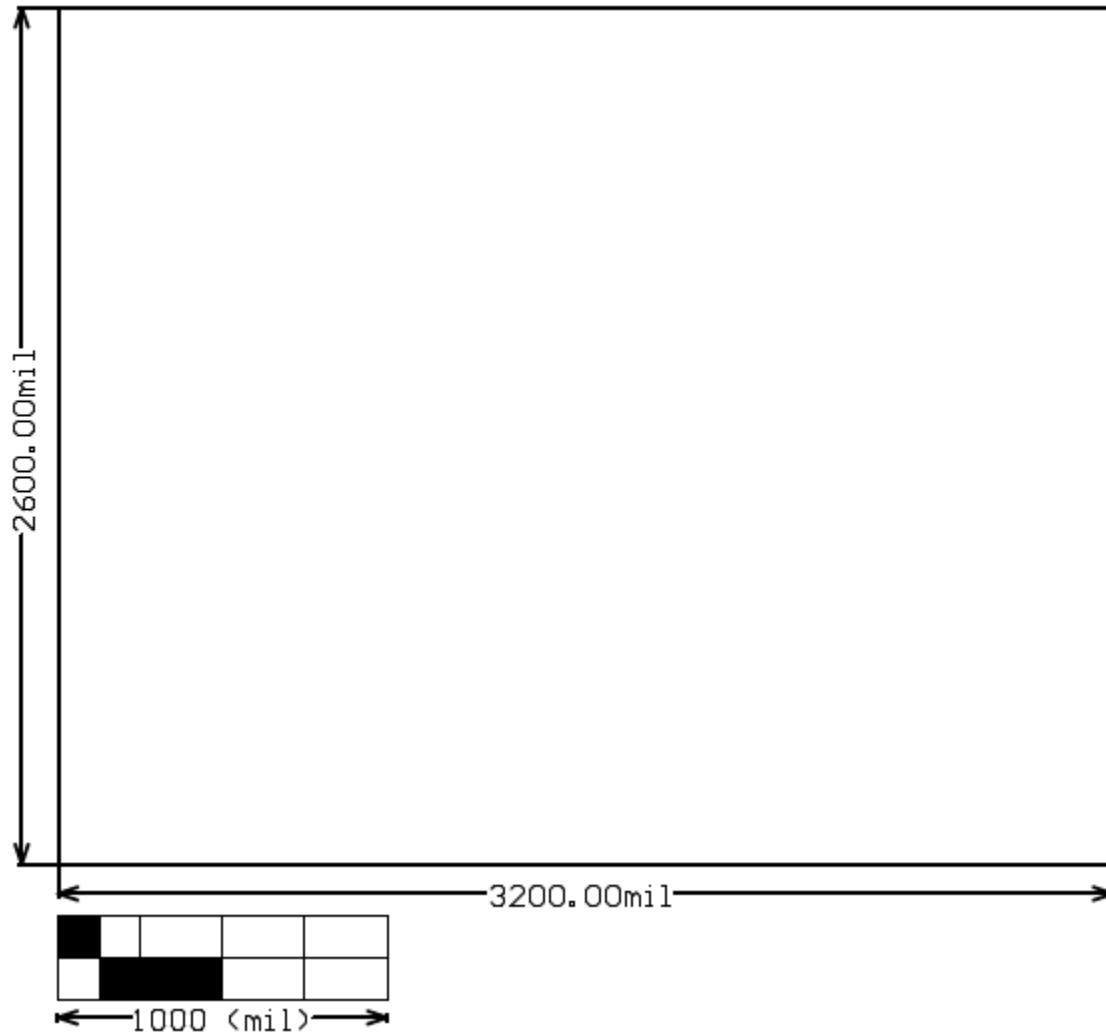

Figure 22. Board Dimensions

13 TDC1000-GASEVM Schematic

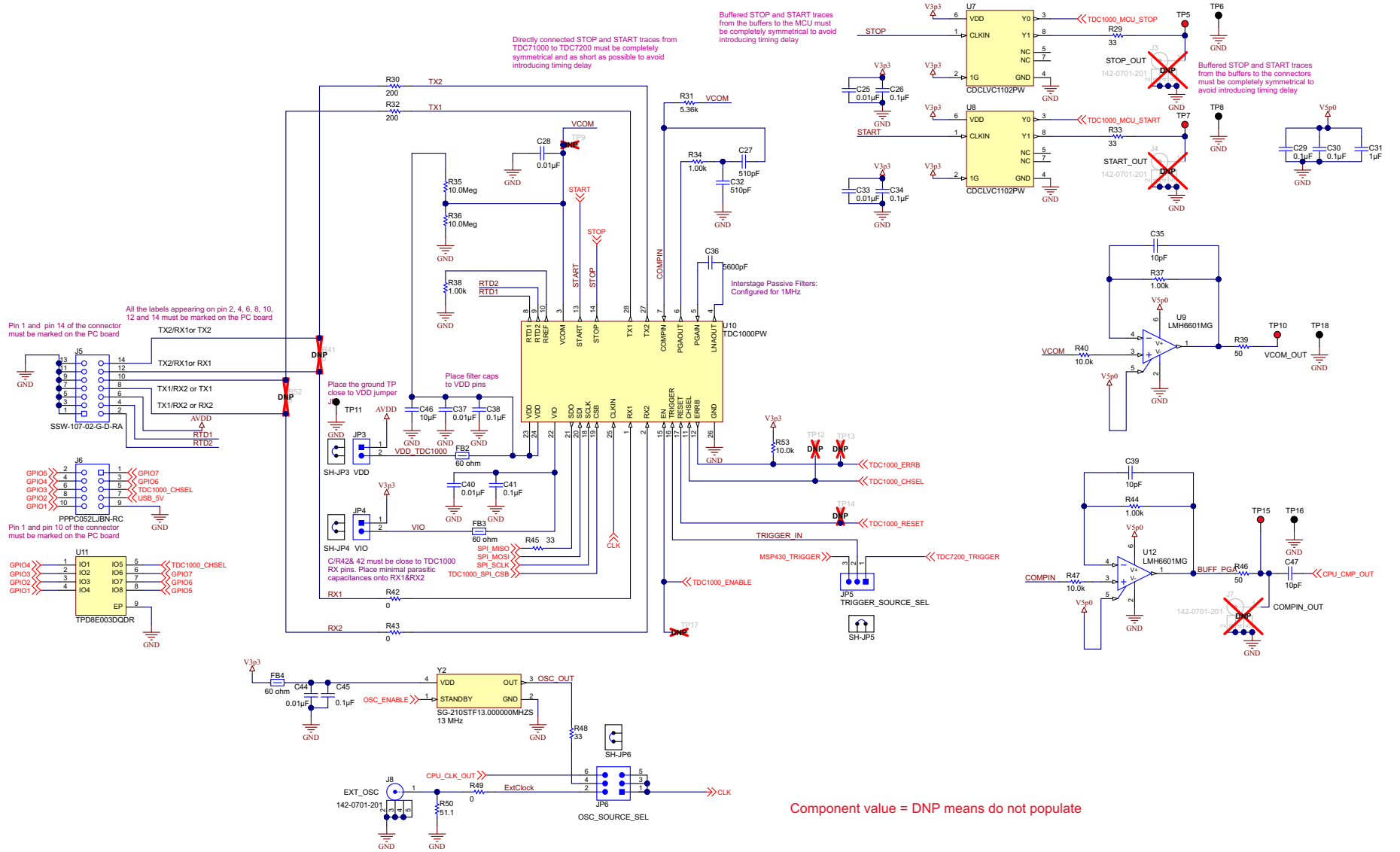
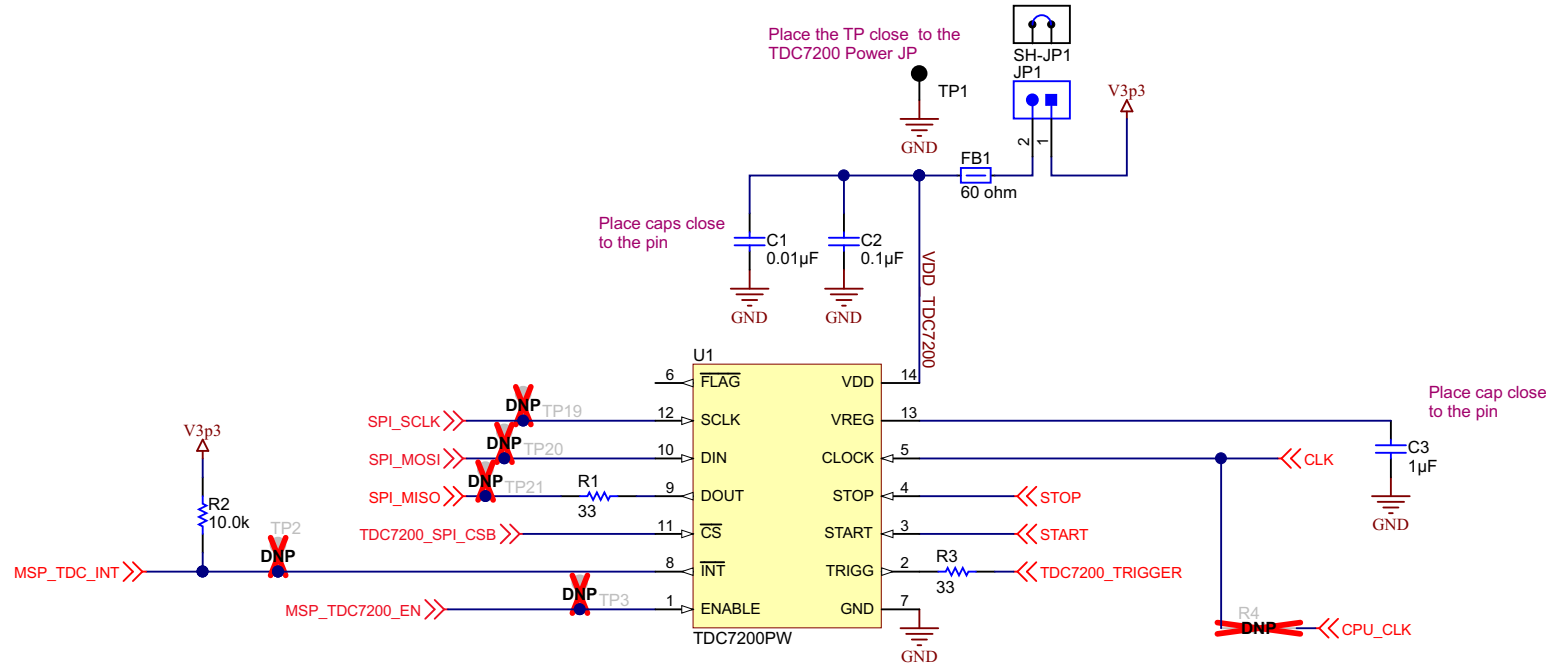

Figure 23. TDC1000-GASEVM Schematic 1



Component value = DNP means do not populate

Figure 24. TDC1000-GASEVM Schematic 2

STOP is connected to TA0.0, as this has quickest responding ISR. In this way STOP pulses can be closer together.
 START is connected to TA0.1, which is slower. This produces a delay to timestamp, but this can be compensated.
 TRIGGER is on TA0.2, used to reset counter so there are no rollover issues.

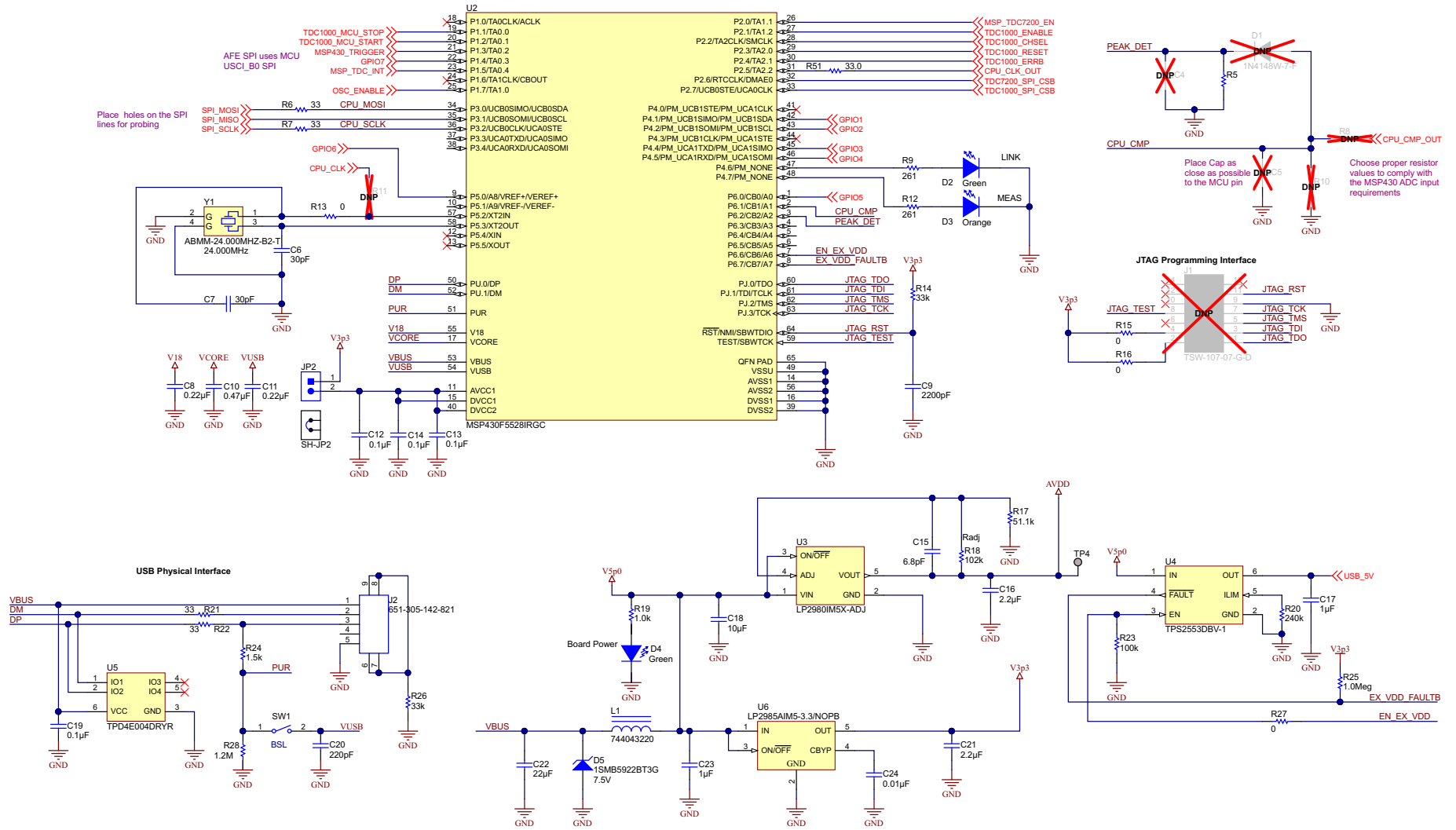

Component value = DNP means do not populate

Figure 25. TDC1000-GASEVM Schematic 3

14 TDC1000-BSTEVM Board Layout

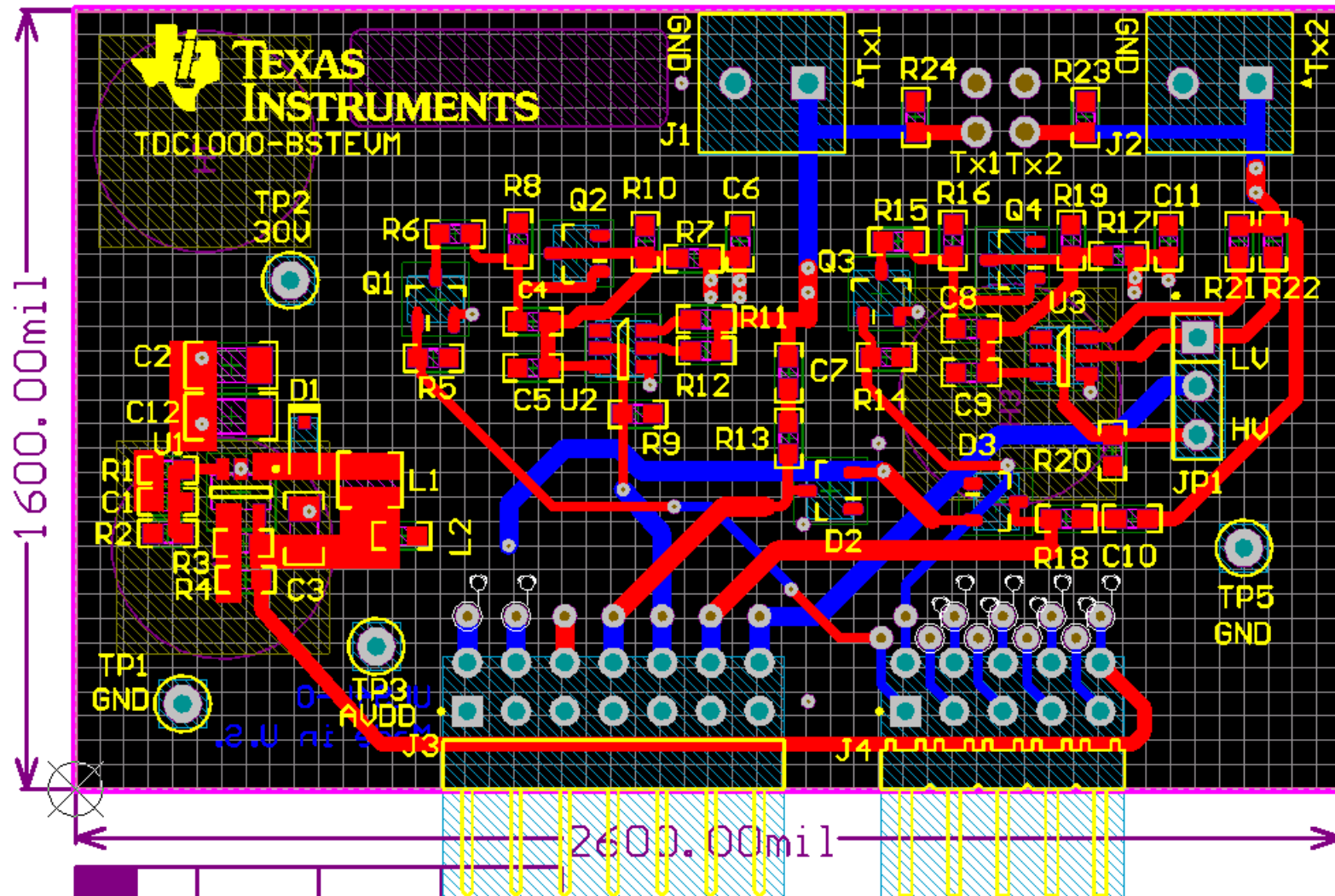

Figure 26. BSTEVM Layout

15 BSTEVM Schematic

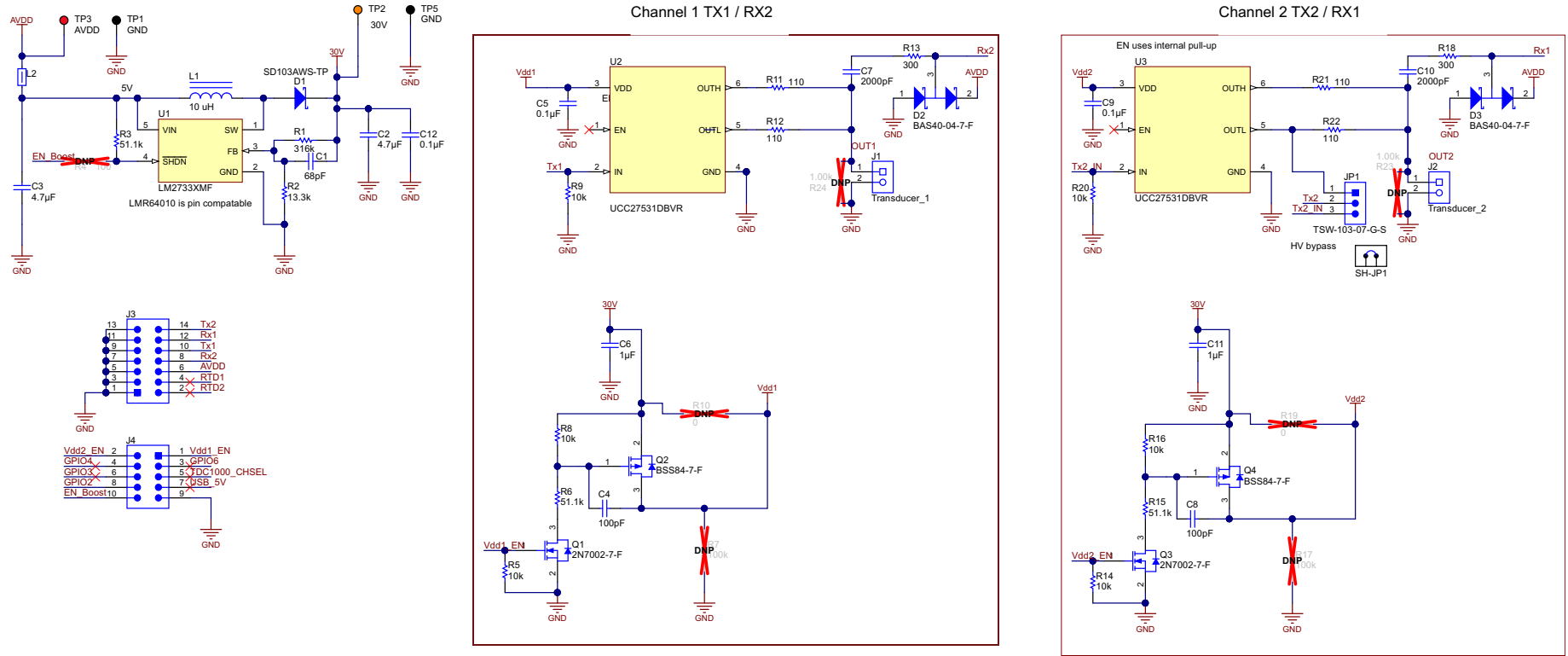

Figure 27. TDC1000-BSTEVM

Revision History

Changes from Original (March 2015) to A Revision	Page
• Changed SETUP Tab.....	3
• Changed SETUP Tab	11
• Changed Schematic.....	29

NOTE: Page numbers for previous revisions may differ from page numbers in the current version.

STANDARD TERMS AND CONDITIONS FOR EVALUATION MODULES

1. *Delivery:* TI delivers TI evaluation boards, kits, or modules, including any accompanying demonstration software, components, or documentation (collectively, an "EVM" or "EVMs") to the User ("User") in accordance with the terms and conditions set forth herein. Acceptance of the EVM is expressly subject to the following terms and conditions.
 - 1.1 EVMs are intended solely for product or software developers for use in a research and development setting to facilitate feasibility evaluation, experimentation, or scientific analysis of TI semiconductors products. EVMs have no direct function and are not finished products. EVMs shall not be directly or indirectly assembled as a part or subassembly in any finished product. For clarification, any software or software tools provided with the EVM ("Software") shall not be subject to the terms and conditions set forth herein but rather shall be subject to the applicable terms and conditions that accompany such Software
 - 1.2 EVMs are not intended for consumer or household use. EVMs may not be sold, sublicensed, leased, rented, loaned, assigned, or otherwise distributed for commercial purposes by Users, in whole or in part, or used in any finished product or production system.
2. *Limited Warranty and Related Remedies/Disclaimers:*
 - 2.1 These terms and conditions do not apply to Software. The warranty, if any, for Software is covered in the applicable Software License Agreement.
 - 2.2 TI warrants that the TI EVM will conform to TI's published specifications for ninety (90) days after the date TI delivers such EVM to User. Notwithstanding the foregoing, TI shall not be liable for any defects that are caused by neglect, misuse or mistreatment by an entity other than TI, including improper installation or testing, or for any EVMs that have been altered or modified in any way by an entity other than TI. Moreover, TI shall not be liable for any defects that result from User's design, specifications or instructions for such EVMs. Testing and other quality control techniques are used to the extent TI deems necessary or as mandated by government requirements. TI does not test all parameters of each EVM.
 - 2.3 If any EVM fails to conform to the warranty set forth above, TI's sole liability shall be at its option to repair or replace such EVM, or credit User's account for such EVM. TI's liability under this warranty shall be limited to EVMs that are returned during the warranty period to the address designated by TI and that are determined by TI not to conform to such warranty. If TI elects to repair or replace such EVM, TI shall have a reasonable time to repair such EVM or provide replacements. Repaired EVMs shall be warranted for the remainder of the original warranty period. Replaced EVMs shall be warranted for a new full ninety (90) day warranty period.
3. *Regulatory Notices:*
 - 3.1 *United States*
 - 3.1.1 *Notice applicable to EVMs not FCC-Approved:*

This kit is designed to allow product developers to evaluate electronic components, circuitry, or software associated with the kit to determine whether to incorporate such items in a finished product and software developers to write software applications for use with the end product. This kit is not a finished product and when assembled may not be resold or otherwise marketed unless all required FCC equipment authorizations are first obtained. Operation is subject to the condition that this product not cause harmful interference to licensed radio stations and that this product accept harmful interference. Unless the assembled kit is designed to operate under part 15, part 18 or part 95 of this chapter, the operator of the kit must operate under the authority of an FCC license holder or must secure an experimental authorization under part 5 of this chapter.
 - 3.1.2 *For EVMs annotated as FCC – FEDERAL COMMUNICATIONS COMMISSION Part 15 Compliant:*

CAUTION

This device complies with part 15 of the FCC Rules. Operation is subject to the following two conditions: (1) This device may not cause harmful interference, and (2) this device must accept any interference received, including interference that may cause undesired operation.

Changes or modifications not expressly approved by the party responsible for compliance could void the user's authority to operate the equipment.

FCC Interference Statement for Class A EVM devices

NOTE: This equipment has been tested and found to comply with the limits for a Class A digital device, pursuant to part 15 of the FCC Rules. These limits are designed to provide reasonable protection against harmful interference when the equipment is operated in a commercial environment. This equipment generates, uses, and can radiate radio frequency energy and, if not installed and used in accordance with the instruction manual, may cause harmful interference to radio communications. Operation of this equipment in a residential area is likely to cause harmful interference in which case the user will be required to correct the interference at his own expense.

FCC Interference Statement for Class B EVM devices

NOTE: This equipment has been tested and found to comply with the limits for a Class B digital device, pursuant to part 15 of the FCC Rules. These limits are designed to provide reasonable protection against harmful interference in a residential installation. This equipment generates, uses and can radiate radio frequency energy and, if not installed and used in accordance with the instructions, may cause harmful interference to radio communications. However, there is no guarantee that interference will not occur in a particular installation. If this equipment does cause harmful interference to radio or television reception, which can be determined by turning the equipment off and on, the user is encouraged to try to correct the interference by one or more of the following measures:

- Reorient or relocate the receiving antenna.
- Increase the separation between the equipment and receiver.
- Connect the equipment into an outlet on a circuit different from that to which the receiver is connected.
- Consult the dealer or an experienced radio/TV technician for help.

3.2 Canada

3.2.1 For EVMs issued with an Industry Canada Certificate of Conformance to RSS-210

Concerning EVMs Including Radio Transmitters:

This device complies with Industry Canada license-exempt RSS standard(s). Operation is subject to the following two conditions: (1) this device may not cause interference, and (2) this device must accept any interference, including interference that may cause undesired operation of the device.

Concernant les EVMs avec appareils radio:

Le présent appareil est conforme aux CNR d'Industrie Canada applicables aux appareils radio exempts de licence. L'exploitation est autorisée aux deux conditions suivantes: (1) l'appareil ne doit pas produire de brouillage, et (2) l'utilisateur de l'appareil doit accepter tout brouillage radioélectrique subi, même si le brouillage est susceptible d'en compromettre le fonctionnement.

Concerning EVMs Including Detachable Antennas:

Under Industry Canada regulations, this radio transmitter may only operate using an antenna of a type and maximum (or lesser) gain approved for the transmitter by Industry Canada. To reduce potential radio interference to other users, the antenna type and its gain should be so chosen that the equivalent isotropically radiated power (e.i.r.p.) is not more than that necessary for successful communication. This radio transmitter has been approved by Industry Canada to operate with the antenna types listed in the user guide with the maximum permissible gain and required antenna impedance for each antenna type indicated. Antenna types not included in this list, having a gain greater than the maximum gain indicated for that type, are strictly prohibited for use with this device.

Concernant les EVMs avec antennes détachables

Conformément à la réglementation d'Industrie Canada, le présent émetteur radio peut fonctionner avec une antenne d'un type et d'un gain maximal (ou inférieur) approuvé pour l'émetteur par Industrie Canada. Dans le but de réduire les risques de brouillage radioélectrique à l'intention des autres utilisateurs, il faut choisir le type d'antenne et son gain de sorte que la puissance isotrope rayonnée équivalente (p.i.r.e.) ne dépasse pas l'intensité nécessaire à l'établissement d'une communication satisfaisante. Le présent émetteur radio a été approuvé par Industrie Canada pour fonctionner avec les types d'antenne énumérés dans le manuel d'usage et ayant un gain admissible maximal et l'impédance requise pour chaque type d'antenne. Les types d'antenne non inclus dans cette liste, ou dont le gain est supérieur au gain maximal indiqué, sont strictement interdits pour l'exploitation de l'émetteur.

3.3 Japan

3.3.1 *Notice for EVMs delivered in Japan:* Please see http://www.tij.co.jp/lstds/ti_ja/general/eStore/notice_01.page 日本国内に輸入される評価用キット、ボードについては、次のところをご覧ください。
http://www.tij.co.jp/lstds/ti_ja/general/eStore/notice_01.page

3.3.2 *Notice for Users of EVMs Considered "Radio Frequency Products" in Japan:* EVMs entering Japan may not be certified by TI as conforming to Technical Regulations of Radio Law of Japan.

If User uses EVMs in Japan, not certified to Technical Regulations of Radio Law of Japan, User is required by Radio Law of Japan to follow the instructions below with respect to EVMs:

1. Use EVMs in a shielded room or any other test facility as defined in the notification #173 issued by Ministry of Internal Affairs and Communications on March 28, 2006, based on Sub-section 1.1 of Article 6 of the Ministry's Rule for Enforcement of Radio Law of Japan,
2. Use EVMs only after User obtains the license of Test Radio Station as provided in Radio Law of Japan with respect to EVMs, or
3. Use of EVMs only after User obtains the Technical Regulations Conformity Certification as provided in Radio Law of Japan with respect to EVMs. Also, do not transfer EVMs, unless User gives the same notice above to the transferee. Please note that if User does not follow the instructions above, User will be subject to penalties of Radio Law of Japan.

【無線電波を送信する製品の開発キットをお使いになる際の注意事項】 開発キットの中には技術基準適合証明を受けていないものがあります。技術適合証明を受けていないもののご使用に際しては、電波法遵守のため、以下のいずれかの措置を取っていただく必要がありますのでご注意ください。

1. 電波法施行規則第6条第1項第1号に基づく平成18年3月28日総務省告示第173号で定められた電波暗室等の試験設備でご使用いただく。
2. 実験局の免許を取得後ご使用いただく。
3. 技術基準適合証明を取得後ご使用いただく。

なお、本製品は、上記の「ご使用にあたっての注意」を譲渡先、移転先に通知しない限り、譲渡、移転できないものとします。

上記を遵守頂けない場合は、電波法の罰則が適用される可能性があることをご留意ください。日本テキサス・インスツルメンツ株式会社
東京都新宿区西新宿 6 丁目 2 4 番 1 号
西新宿三井ビル

3.3.3 *Notice for EVMs for Power Line Communication:* Please see http://www.tij.co.jp/llds/ti_ja/general/eStore/notice_02.page
電力線搬送波通信についての開発キットをお使いになる際の注意事項については、次のところをご覧ください。http://www.tij.co.jp/llds/ti_ja/general/eStore/notice_02.page

4 *EVM Use Restrictions and Warnings:*

4.1 EVMS ARE NOT FOR USE IN FUNCTIONAL SAFETY AND/OR SAFETY CRITICAL EVALUATIONS, INCLUDING BUT NOT LIMITED TO EVALUATIONS OF LIFE SUPPORT APPLICATIONS.

4.2 User must read and apply the user guide and other available documentation provided by TI regarding the EVM prior to handling or using the EVM, including without limitation any warning or restriction notices. The notices contain important safety information related to, for example, temperatures and voltages.

4.3 *Safety-Related Warnings and Restrictions:*

4.3.1 User shall operate the EVM within TI's recommended specifications and environmental considerations stated in the user guide, other available documentation provided by TI, and any other applicable requirements and employ reasonable and customary safeguards. Exceeding the specified performance ratings and specifications (including but not limited to input and output voltage, current, power, and environmental ranges) for the EVM may cause personal injury or death, or property damage. If there are questions concerning performance ratings and specifications, User should contact a TI field representative prior to connecting interface electronics including input power and intended loads. Any loads applied outside of the specified output range may also result in unintended and/or inaccurate operation and/or possible permanent damage to the EVM and/or interface electronics. Please consult the EVM user guide prior to connecting any load to the EVM output. If there is uncertainty as to the load specification, please contact a TI field representative. During normal operation, even with the inputs and outputs kept within the specified allowable ranges, some circuit components may have elevated case temperatures. These components include but are not limited to linear regulators, switching transistors, pass transistors, current sense resistors, and heat sinks, which can be identified using the information in the associated documentation. When working with the EVM, please be aware that the EVM may become very warm.

4.3.2 EVMs are intended solely for use by technically qualified, professional electronics experts who are familiar with the dangers and application risks associated with handling electrical mechanical components, systems, and subsystems. User assumes all responsibility and liability for proper and safe handling and use of the EVM by User or its employees, affiliates, contractors or designees. User assumes all responsibility and liability to ensure that any interfaces (electronic and/or mechanical) between the EVM and any human body are designed with suitable isolation and means to safely limit accessible leakage currents to minimize the risk of electrical shock hazard. User assumes all responsibility and liability for any improper or unsafe handling or use of the EVM by User or its employees, affiliates, contractors or designees.

4.4 User assumes all responsibility and liability to determine whether the EVM is subject to any applicable international, federal, state, or local laws and regulations related to User's handling and use of the EVM and, if applicable, User assumes all responsibility and liability for compliance in all respects with such laws and regulations. User assumes all responsibility and liability for proper disposal and recycling of the EVM consistent with all applicable international, federal, state, and local requirements.

5. *Accuracy of Information:* To the extent TI provides information on the availability and function of EVMs, TI attempts to be as accurate as possible. However, TI does not warrant the accuracy of EVM descriptions, EVM availability or other information on its websites as accurate, complete, reliable, current, or error-free.

6. *Disclaimers:*
- 6.1 EXCEPT AS SET FORTH ABOVE, EVMS AND ANY WRITTEN DESIGN MATERIALS PROVIDED WITH THE EVM (AND THE DESIGN OF THE EVM ITSELF) ARE PROVIDED "AS IS" AND "WITH ALL FAULTS." TI DISCLAIMS ALL OTHER WARRANTIES, EXPRESS OR IMPLIED, REGARDING SUCH ITEMS, INCLUDING BUT NOT LIMITED TO ANY IMPLIED WARRANTIES OF MERCHANTABILITY OR FITNESS FOR A PARTICULAR PURPOSE OR NON-INFRINGEMENT OF ANY THIRD PARTY PATENTS, COPYRIGHTS, TRADE SECRETS OR OTHER INTELLECTUAL PROPERTY RIGHTS.
- 6.2 EXCEPT FOR THE LIMITED RIGHT TO USE THE EVM SET FORTH HEREIN, NOTHING IN THESE TERMS AND CONDITIONS SHALL BE CONSTRUED AS GRANTING OR CONFERRING ANY RIGHTS BY LICENSE, PATENT, OR ANY OTHER INDUSTRIAL OR INTELLECTUAL PROPERTY RIGHT OF TI, ITS SUPPLIERS/LICENSORS OR ANY OTHER THIRD PARTY, TO USE THE EVM IN ANY FINISHED END-USER OR READY-TO-USE FINAL PRODUCT, OR FOR ANY INVENTION, DISCOVERY OR IMPROVEMENT MADE, CONCEIVED OR ACQUIRED PRIOR TO OR AFTER DELIVERY OF THE EVM.
7. *USER'S INDEMNITY OBLIGATIONS AND REPRESENTATIONS.* USER WILL DEFEND, INDEMNIFY AND HOLD TI, ITS LICENSORS AND THEIR REPRESENTATIVES HARMLESS FROM AND AGAINST ANY AND ALL CLAIMS, DAMAGES, LOSSES, EXPENSES, COSTS AND LIABILITIES (COLLECTIVELY, "CLAIMS") ARISING OUT OF OR IN CONNECTION WITH ANY HANDLING OR USE OF THE EVM THAT IS NOT IN ACCORDANCE WITH THESE TERMS AND CONDITIONS. THIS OBLIGATION SHALL APPLY WHETHER CLAIMS ARISE UNDER STATUTE, REGULATION, OR THE LAW OF TORT, CONTRACT OR ANY OTHER LEGAL THEORY, AND EVEN IF THE EVM FAILS TO PERFORM AS DESCRIBED OR EXPECTED.
8. *Limitations on Damages and Liability:*
- 8.1 *General Limitations.* IN NO EVENT SHALL TI BE LIABLE FOR ANY SPECIAL, COLLATERAL, INDIRECT, PUNITIVE, INCIDENTAL, CONSEQUENTIAL, OR EXEMPLARY DAMAGES IN CONNECTION WITH OR ARISING OUT OF THESE TERMS AND CONDITIONS OR THE USE OF THE EVMS PROVIDED HEREUNDER, REGARDLESS OF WHETHER TI HAS BEEN ADVISED OF THE POSSIBILITY OF SUCH DAMAGES. EXCLUDED DAMAGES INCLUDE, BUT ARE NOT LIMITED TO, COST OF REMOVAL OR REINSTALLATION, ANCILLARY COSTS TO THE PROCUREMENT OF SUBSTITUTE GOODS OR SERVICES, RETESTING, OUTSIDE COMPUTER TIME, LABOR COSTS, LOSS OF GOODWILL, LOSS OF PROFITS, LOSS OF SAVINGS, LOSS OF USE, LOSS OF DATA, OR BUSINESS INTERRUPTION. NO CLAIM, SUIT OR ACTION SHALL BE BROUGHT AGAINST TI MORE THAN ONE YEAR AFTER THE RELATED CAUSE OF ACTION HAS OCCURRED.
- 8.2 *Specific Limitations.* IN NO EVENT SHALL TI'S AGGREGATE LIABILITY FROM ANY WARRANTY OR OTHER OBLIGATION ARISING OUT OF OR IN CONNECTION WITH THESE TERMS AND CONDITIONS, OR ANY USE OF ANY TI EVM PROVIDED HEREUNDER, EXCEED THE TOTAL AMOUNT PAID TO TI FOR THE PARTICULAR UNITS SOLD UNDER THESE TERMS AND CONDITIONS WITH RESPECT TO WHICH LOSSES OR DAMAGES ARE CLAIMED. THE EXISTENCE OF MORE THAN ONE CLAIM AGAINST THE PARTICULAR UNITS SOLD TO USER UNDER THESE TERMS AND CONDITIONS SHALL NOT ENLARGE OR EXTEND THIS LIMIT.
9. *Return Policy.* Except as otherwise provided, TI does not offer any refunds, returns, or exchanges. Furthermore, no return of EVM(s) will be accepted if the package has been opened and no return of the EVM(s) will be accepted if they are damaged or otherwise not in a resalable condition. If User feels it has been incorrectly charged for the EVM(s) it ordered or that delivery violates the applicable order, User should contact TI. All refunds will be made in full within thirty (30) working days from the return of the components(s), excluding any postage or packaging costs.
10. *Governing Law:* These terms and conditions shall be governed by and interpreted in accordance with the laws of the State of Texas, without reference to conflict-of-laws principles. User agrees that non-exclusive jurisdiction for any dispute arising out of or relating to these terms and conditions lies within courts located in the State of Texas and consents to venue in Dallas County, Texas. Notwithstanding the foregoing, any judgment may be enforced in any United States or foreign court, and TI may seek injunctive relief in any United States or foreign court.

Mailing Address: Texas Instruments, Post Office Box 655303, Dallas, Texas 75265
Copyright © 2015, Texas Instruments Incorporated

IMPORTANT NOTICE

Texas Instruments Incorporated and its subsidiaries (TI) reserve the right to make corrections, enhancements, improvements and other changes to its semiconductor products and services per JESD46, latest issue, and to discontinue any product or service per JESD48, latest issue. Buyers should obtain the latest relevant information before placing orders and should verify that such information is current and complete. All semiconductor products (also referred to herein as "components") are sold subject to TI's terms and conditions of sale supplied at the time of order acknowledgment.

TI warrants performance of its components to the specifications applicable at the time of sale, in accordance with the warranty in TI's terms and conditions of sale of semiconductor products. Testing and other quality control techniques are used to the extent TI deems necessary to support this warranty. Except where mandated by applicable law, testing of all parameters of each component is not necessarily performed.

TI assumes no liability for applications assistance or the design of Buyers' products. Buyers are responsible for their products and applications using TI components. To minimize the risks associated with Buyers' products and applications, Buyers should provide adequate design and operating safeguards.

TI does not warrant or represent that any license, either express or implied, is granted under any patent right, copyright, mask work right, or other intellectual property right relating to any combination, machine, or process in which TI components or services are used. Information published by TI regarding third-party products or services does not constitute a license to use such products or services or a warranty or endorsement thereof. Use of such information may require a license from a third party under the patents or other intellectual property of the third party, or a license from TI under the patents or other intellectual property of TI.

Reproduction of significant portions of TI information in TI data books or data sheets is permissible only if reproduction is without alteration and is accompanied by all associated warranties, conditions, limitations, and notices. TI is not responsible or liable for such altered documentation. Information of third parties may be subject to additional restrictions.

Resale of TI components or services with statements different from or beyond the parameters stated by TI for that component or service voids all express and any implied warranties for the associated TI component or service and is an unfair and deceptive business practice. TI is not responsible or liable for any such statements.

Buyer acknowledges and agrees that it is solely responsible for compliance with all legal, regulatory and safety-related requirements concerning its products, and any use of TI components in its applications, notwithstanding any applications-related information or support that may be provided by TI. Buyer represents and agrees that it has all the necessary expertise to create and implement safeguards which anticipate dangerous consequences of failures, monitor failures and their consequences, lessen the likelihood of failures that might cause harm and take appropriate remedial actions. Buyer will fully indemnify TI and its representatives against any damages arising out of the use of any TI components in safety-critical applications.

In some cases, TI components may be promoted specifically to facilitate safety-related applications. With such components, TI's goal is to help enable customers to design and create their own end-product solutions that meet applicable functional safety standards and requirements. Nonetheless, such components are subject to these terms.

No TI components are authorized for use in FDA Class III (or similar life-critical medical equipment) unless authorized officers of the parties have executed a special agreement specifically governing such use.

Only those TI components which TI has specifically designated as military grade or "enhanced plastic" are designed and intended for use in military/aerospace applications or environments. Buyer acknowledges and agrees that any military or aerospace use of TI components which have **not** been so designated is solely at the Buyer's risk, and that Buyer is solely responsible for compliance with all legal and regulatory requirements in connection with such use.

TI has specifically designated certain components as meeting ISO/TS16949 requirements, mainly for automotive use. In any case of use of non-designated products, TI will not be responsible for any failure to meet ISO/TS16949.

Products

Audio	www.ti.com/audio
Amplifiers	amplifier.ti.com
Data Converters	dataconverter.ti.com
DLP® Products	www.dlp.com
DSP	dsp.ti.com
Clocks and Timers	www.ti.com/clocks
Interface	interface.ti.com
Logic	logic.ti.com
Power Mgmt	power.ti.com
Microcontrollers	microcontroller.ti.com
RFID	www.ti-rfid.com
OMAP Applications Processors	www.ti.com/omap
Wireless Connectivity	www.ti.com/wirelessconnectivity

Applications

Automotive and Transportation	www.ti.com/automotive
Communications and Telecom	www.ti.com/communications
Computers and Peripherals	www.ti.com/computers
Consumer Electronics	www.ti.com/consumer-apps
Energy and Lighting	www.ti.com/energy
Industrial	www.ti.com/industrial
Medical	www.ti.com/medical
Security	www.ti.com/security
Space, Avionics and Defense	www.ti.com/space-avionics-defense
Video and Imaging	www.ti.com/video

TI E2E Community

e2e.ti.com