

LA0152CS

Ambient Light Sensor, Linear Current Output, with Standby Function



ON Semiconductor[®]
www.onsemi.com

Overview

The LA0152CS is a photo IC for ultra-small package ambient light sensor which has the characteristics of spectral response similar to that of human eyes. It is suitable for applications like mobile phone, laptop computer, PDA, DSC and Camcorder.

Features

- Smallest OD-CSP package in the world (1.01mm x 1.01mm x thickness: 0.6mm)
- Low variation and Optical Output Current in low temperature fluctuation.
- Integrated Sleep function.
- Low current consumption.

Typical Applications

- Mobile phones and tablets
- Digital still cameras
- Security camera

SPECIFICATION

ABSOLUTE MAXIMUM RATINGS at Ta = 25°C (Note 1)

Parameter	Symbol	Conditions	Ratings	Unit
Maximum supply voltage	V _{CC}		6	V
Operating temperature	T _{opr}		-30 to +85	°C
Storage temperature	T _{stg}		-40 to +100	°C

1. Stresses exceeding those listed in the Absolute Maximum Rating table may damage the device. If any of these limits are exceeded, device functionality should not be assumed, damage may occur and reliability may be affected.

RECOMMENDED OPERATING CONDITIONS AND

OPERATING VOLTAGE RANGE at Ta = 25°C (Note 2)

Parameter	Symbol	Conditions	Ratings			Unit
			min	typ	max	
SW pin low voltage	V _l	Sleep mode	0		0.4	V
SW pin high voltage	V _h	Active mode	1.4		V _{CC}	V

2. Functional operation above the stresses listed in the Recommended Operating Ranges is not implied. Extended exposure to stresses beyond the Recommended Operating Ranges limits may affect device reliability.

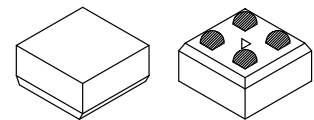

ODCSP4 1.01 mm x 1.01 mm

ORDERING INFORMATION

Ordering Code:
LA0152CS-TLM-H

Package
ODCSP4
(Pb-Free / Halogen Free)

Shipping (Qty / packing)
5000 / Tape & Reel

† For information on tape and reel specifications, including part orientation and tape sizes, please refer to our Tape and Reel Packaging Specifications Brochure, BRD8011/D.
http://www.onsemi.com/pub_link/Collateral/BRD8011-D.PDF

LA0152CS

ELECTRICAL AND OPTICAL CHARACTERISTICS at $T_a = 25^\circ\text{C}$, $V_{CC} = 3.3\text{V}$ (Note 3)

Parameter	Symbol	Conditions	Ratings			Unit
			min	typ	max	
Recommended Supply Voltage	V_{CC}		2.2	3.3	5.5	V
Current dissipation (Note 4, 6)	I_{CC}	$E_v = 1000 \text{ lux}$, $R_L = 5\text{k}\Omega$	90	150	210	μA
Sleep Current(1) (Note 6)	I_{SL1}	$E_v = 0 \text{ lux}$			0.1	μA
Sleep Current(1) (Note 6)	I_{SL2}	$E_v = 1000 \text{ lux}$			0.3	μA
Output current (2) (Note 4,6)	I_{O1}	$E_v = 100 \text{ lx}$	6	8	10	μA
Output current (2) (Note 4,6)	I_{O2}	$E_v = 1000 \text{ lx}$	60	80	100	μA
Dark current (Note 6)	I_{leak}	$E_v = 0 \text{ lx}$			0.1	μA
Temperature coefficient (Note 5)	I_{tc}	$E_v = 100 \text{ lx}$		0.34		$\%/\text{C}$
Rise time (Note 7)	T_r	$E_v = 1000 \text{ lx}$, $R_L = 5\text{k}\Omega$		15	40	μs
Fall time (Note 7)	T_f	$E_v = 1000 \text{ lx}$, $R_L = 5\text{k}\Omega$		150	500	μs
Peak sensitivity wave length (Note 5)	λ_p			550		nm
Saturation output voltage (Note 4,6)	V_O	$E_v = 1000 \text{ lx}$, $R_L = 150\text{k}\Omega$	3.0	3.2		V

3. Product parametric performance is indicated in the Electrical Characteristics for the listed test conditions, unless otherwise noted. Product performance may not be indicated by the Electrical Characteristics if operated under different conditions.

4. Measured with the standard light source A. White LED is used instead in the mass production line.

5. Design guaranteed item

6. Test circuit for measuring current dissipation and output current

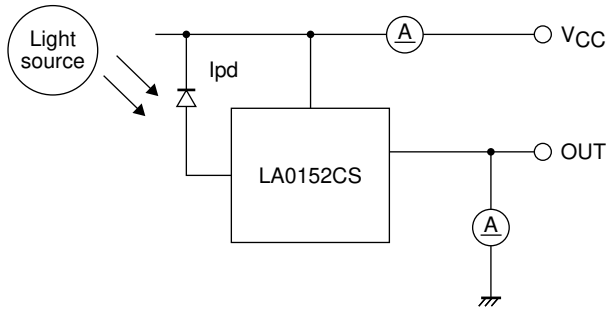

7. Measuring method of rise time (T_r) and fall time (T_f)

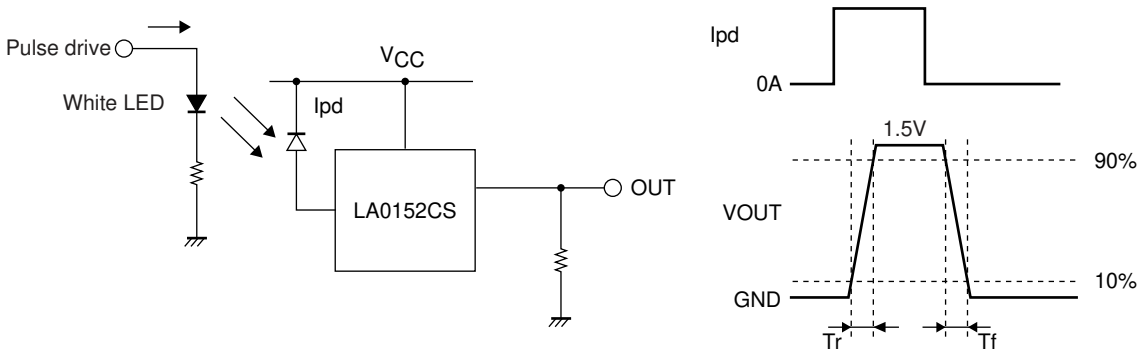

LA0152CS

PAD LAYOUT

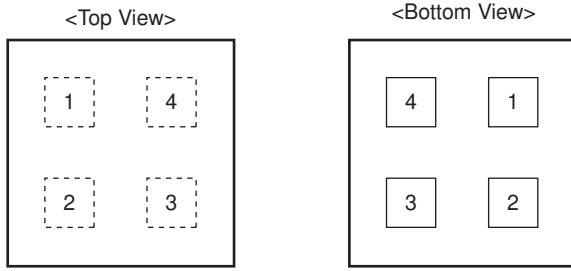

Pin No.	Pin Name	Function
1	V _{CC}	Power supply
2	EN	Enable
3	GND	Ground
4	OUT	Output

Ball pitch : 0.5mm, Ball size : 0.18mm □

PAD LAYOUT (Photos)

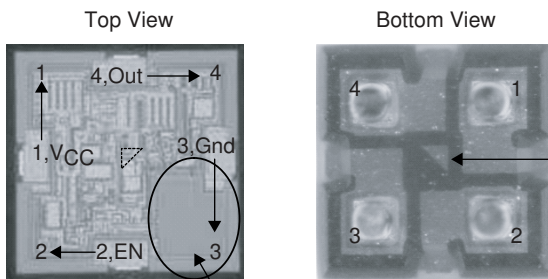

Pin 1 mark
It is located at the center of the bottom of the package.

Photo diode. Only this part looks dark on the product.

* The photo diode is located in pin 3. Be careful not to mistake the pin 1 mark for the photo diode.

INTRNAL BLOCK DIAGRAM

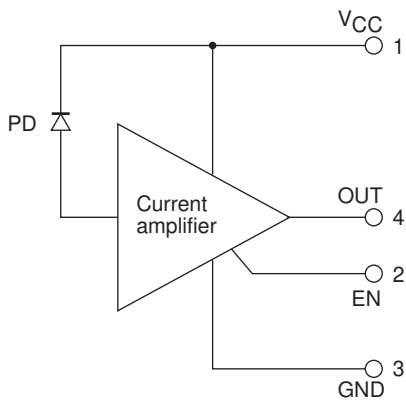

LA0152CS

CHIP PATTERN AND PHOTO-RECEIVING PATTERN DIAGRAMS

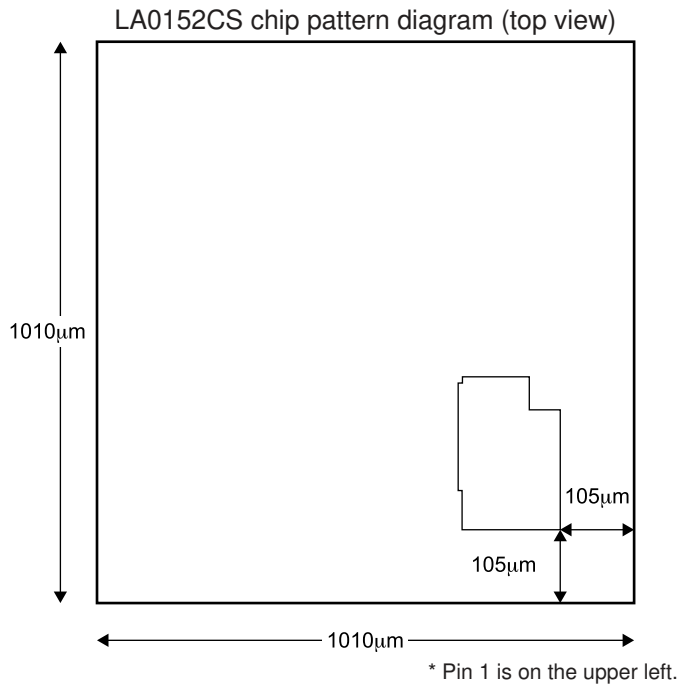

LA0152CS photo-receiving pattern enlarged diagram (effective area)

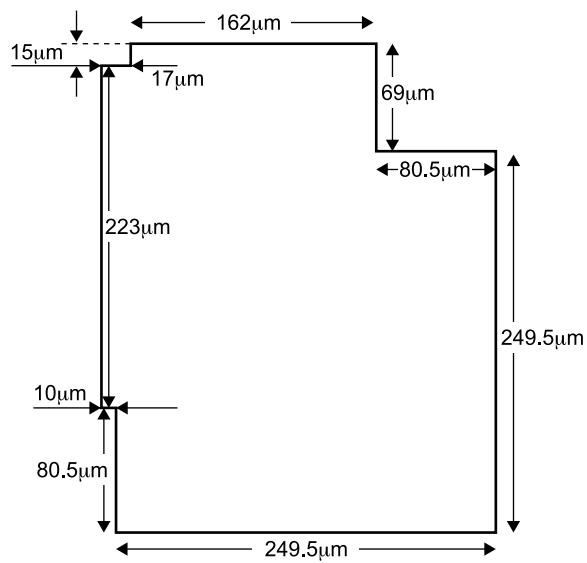

LA0152CS

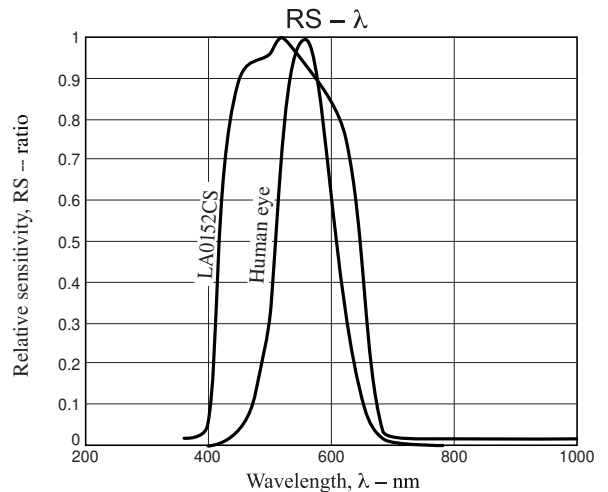
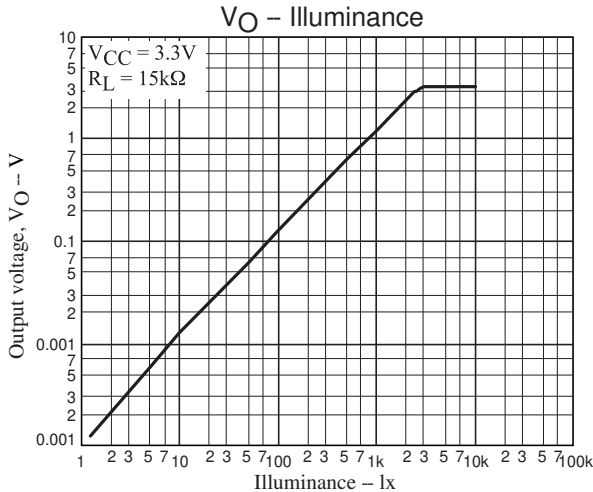
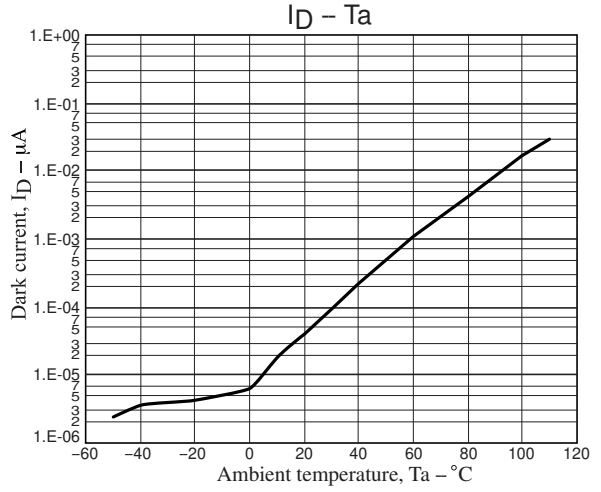
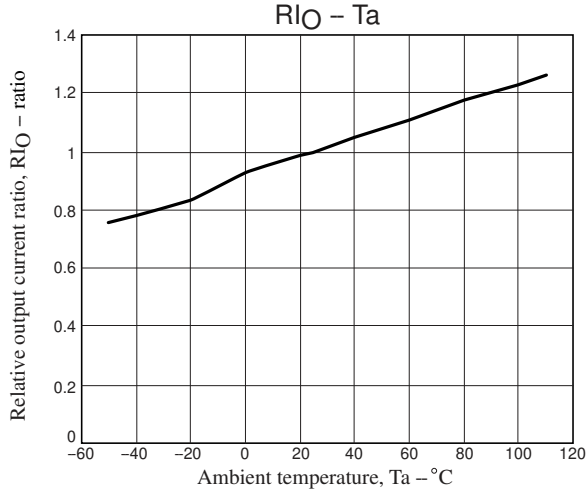
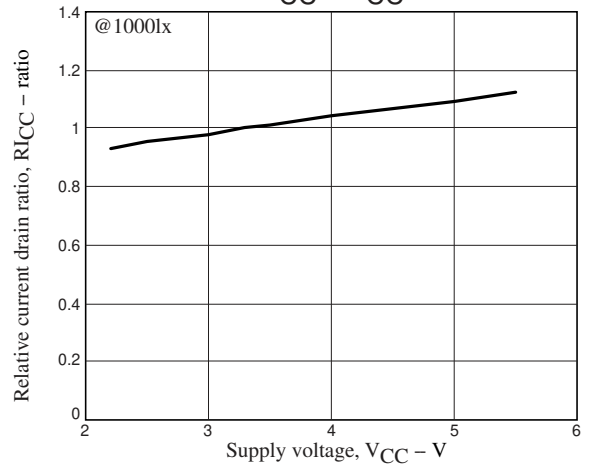
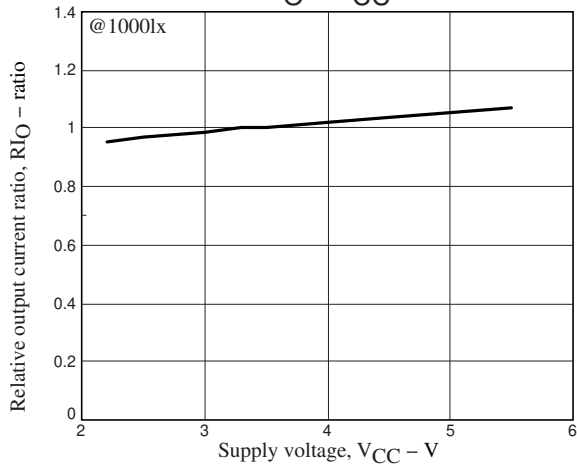
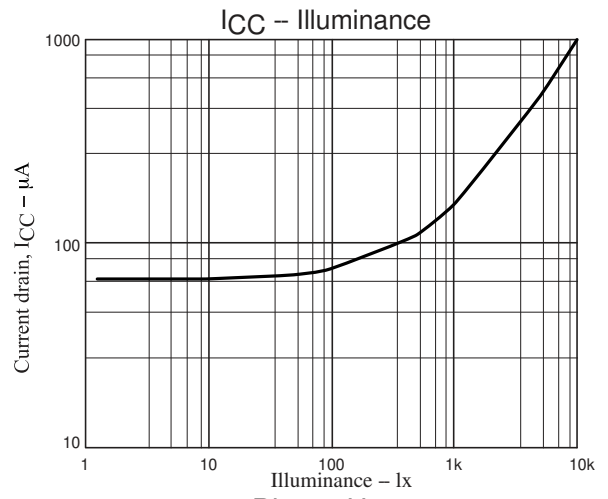
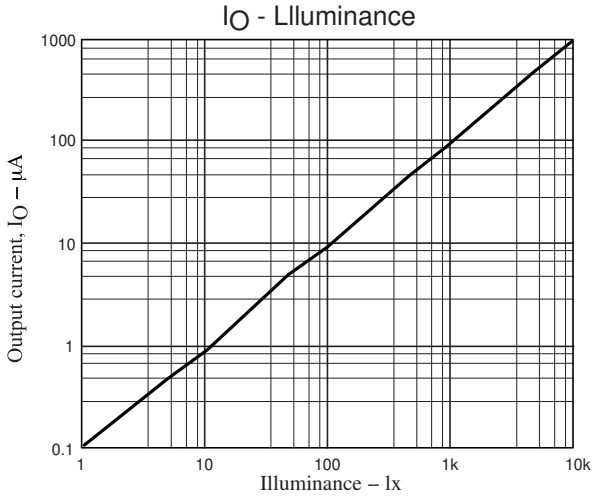

LA0152CS

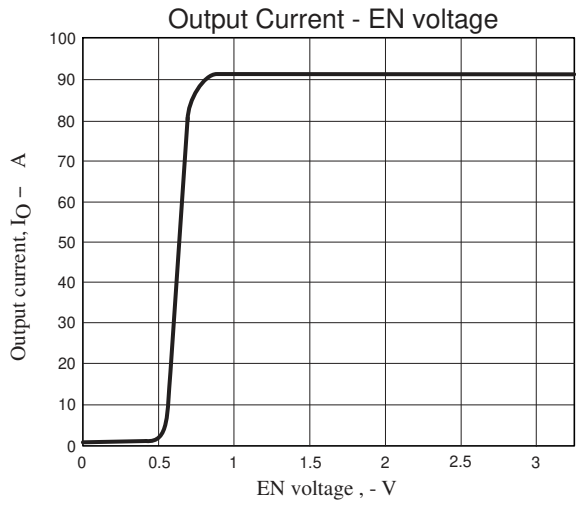
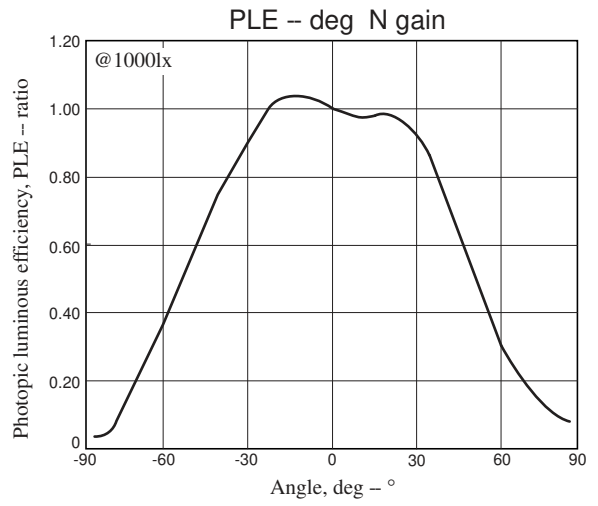
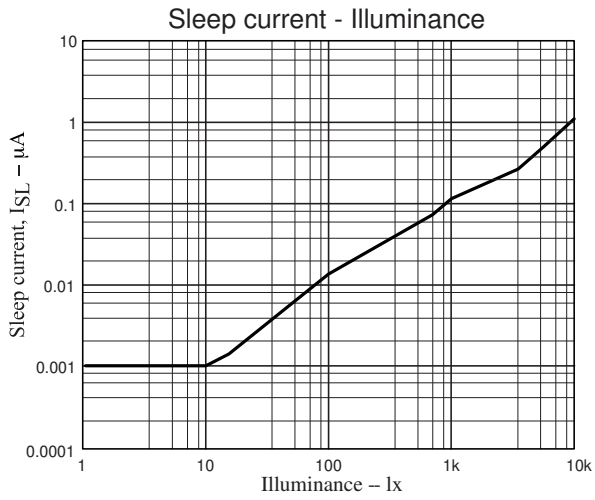

LA0152CS

PACKAGE DIMENSIONS

unit : mm

ODCSP4 1.01x1.01

CASE 570AC

ISSUE O

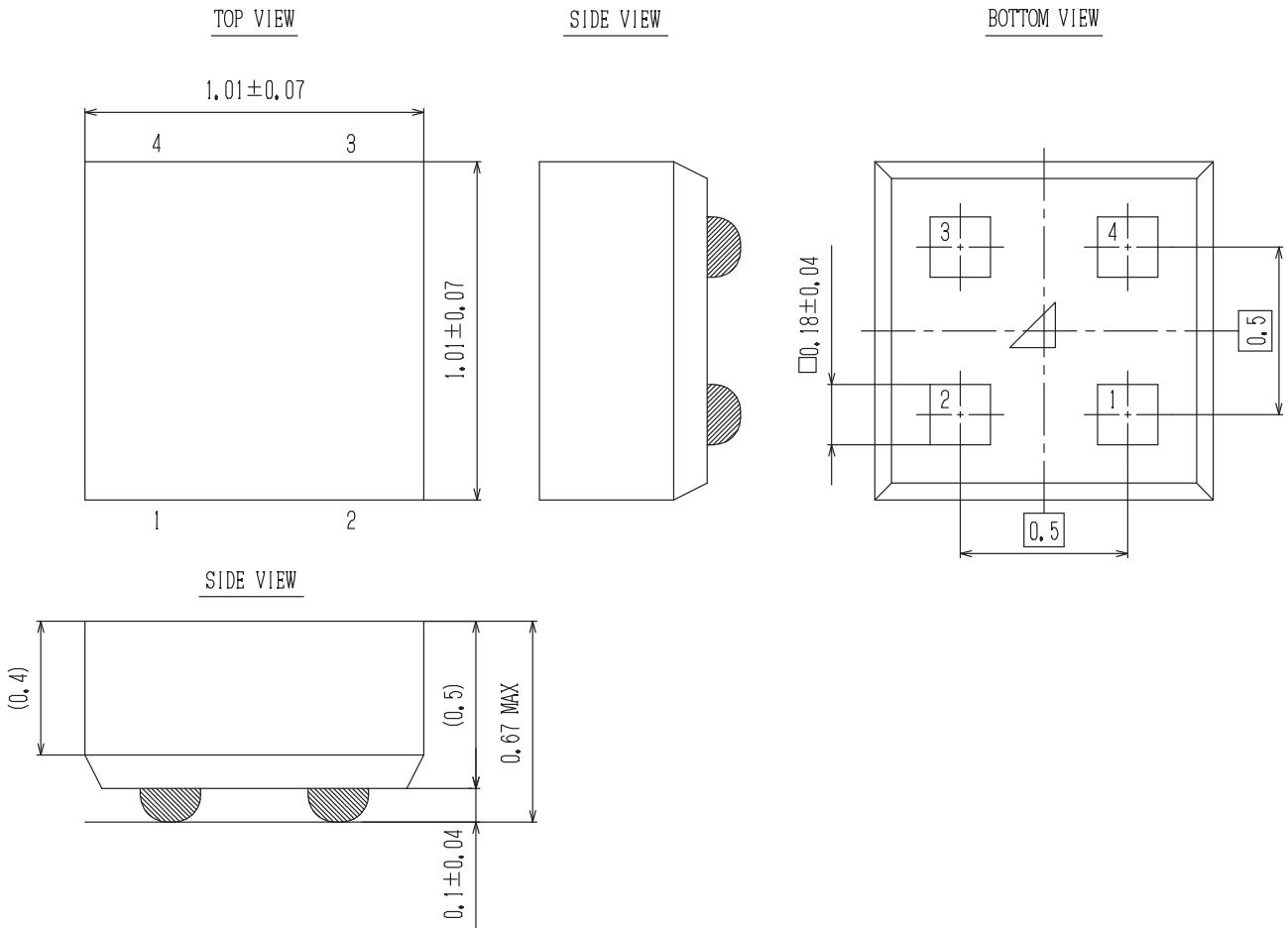

ON Semiconductor and the ON logo are registered trademarks of Semiconductor Components Industries, LLC (SCILLC) or its subsidiaries in the United States and/or other countries. SCILLC owns the rights to a number of patents, trademarks, copyrights, trade secrets, and other intellectual property. A listing of SCILLC's product/patent coverage may be accessed at www.onsemi.com/site/pdf/Patent-Marking.pdf. SCILLC reserves the right to make changes without further notice to any products herein. SCILLC makes no warranty, representation or guarantee regarding the suitability of its products for any particular purpose, nor does SCILLC assume any liability arising out of the application or use of any product or circuit, and specifically disclaims any and all liability, including without limitation special, consequential or incidental damages. "Typical" parameters which may be provided in SCILLC data sheets and/or specifications can and do vary in different applications and actual performance may vary over time. All operating parameters, including "Typicals" must be validated for each customer application by customer's technical experts. SCILLC does not convey any license under its patent rights nor the rights of others. SCILLC products are not designed, intended, or authorized for use as components in systems intended for surgical implant into the body, or other applications intended to support or sustain life, or for any other application in which the failure of the SCILLC product could create a situation where personal injury or death may occur. Should Buyer purchase or use SCILLC products for any such unintended or unauthorized application, Buyer shall indemnify and hold SCILLC and its officers, employees, subsidiaries, affiliates, and distributors harmless against all claims, costs, damages, and expenses, and reasonable attorney fees arising out of, directly or indirectly, any claim of personal injury or death associated with such unintended or unauthorized use, even if such claim alleges that SCILLC was negligent regarding the design or manufacture of the part. SCILLC is an Equal Opportunity/Affirmative Action Employer. This literature is subject to all applicable copyright laws and is not for resale in any manner.