

*Single switch  
Series & parallel diodes  
MOSFET Power Module*

**$V_{DSS} = 1000V$   
 $R_{DSon} = 130m\Omega$  typ @  $T_j = 25^\circ C$   
 $I_D = 65A$  @  $T_c = 25^\circ C$**

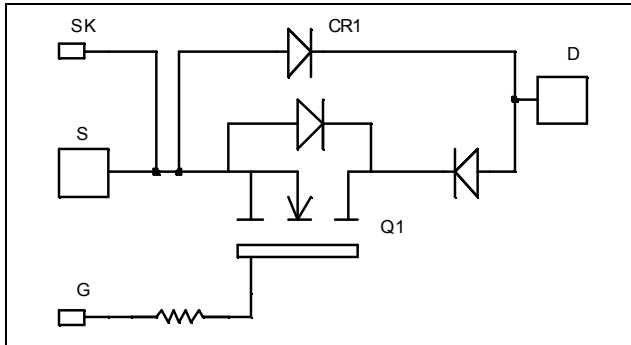

**Application**

- Motor control
- Switched Mode Power Supplies
- Uninterruptible Power Supplies

**Features**

- Power MOS V<sup>®</sup> MOSFETs
  - Low  $R_{DSon}$
  - Low input and Miller capacitance
  - Low gate charge
  - Avalanche energy rated
  - Very rugged
- Kelvin source for easy drive
- Very low stray inductance

**Benefits**

- Outstanding performance at high frequency operation
- Direct mounting to heatsink (isolated package)
- Low junction to case thermal resistance

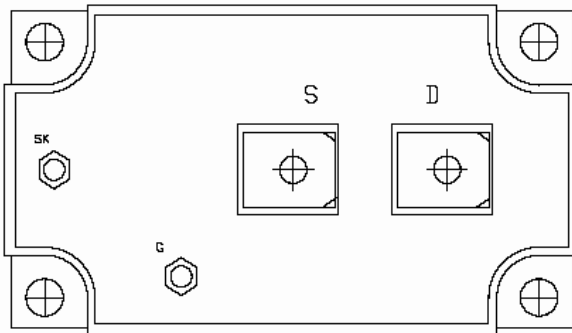

**Absolute maximum ratings**

<i>Symbol</i>	<i>Parameter</i>	<i>Max ratings</i>	<i>Unit</i>
$V_{DSS}$	Drain - Source Breakdown Voltage	1000	V
$I_D$	Continuous Drain Current	$T_c = 25^\circ C$	65
		$T_c = 80^\circ C$	48
$I_{DM}$	Pulsed Drain current	260	A
$V_{GS}$	Gate - Source Voltage	$\pm 30$	V
$R_{DSon}$	Drain - Source ON Resistance	145	$m\Omega$
$P_D$	Maximum Power Dissipation	$T_c = 25^\circ C$	1250
$I_{AR}$	Avalanche current (repetitive and non repetitive)	17	A
$E_{AR}$	Repetitive Avalanche Energy	50	mJ
$E_{AS}$	Single Pulse Avalanche Energy	2500	

**CAUTION:** These Devices are sensitive to Electrostatic Discharge. Proper Handling Procedures Should Be Followed.

All ratings @  $T_j = 25^\circ\text{C}$  unless otherwise specified

### Electrical Characteristics

Symbol	Characteristic	Test Conditions	Min	Typ	Max	Unit
$I_{DSS}$	Zero Gate Voltage Drain Current	$V_{GS} = 0V, V_{DS} = 1000V$			100	$\mu\text{A}$
		$T_j = 25^\circ\text{C}$				
$R_{DS(on)}$	Drain – Source on Resistance	$V_{GS} = 0V, V_{DS} = 800V$			400	$\text{m}\Omega$
		$T_j = 125^\circ\text{C}$				
$R_{DS(on)}$	Drain – Source on Resistance	$V_{GS} = 10V, I_D = 32.5A$		130	145	$\text{m}\Omega$
$V_{GS(th)}$	Gate Threshold Voltage	$V_{GS} = V_{DS}, I_D = 10\text{mA}$	2		4	V
$I_{CSS}$	Gate – Source Leakage Current	$V_{GS} = \pm 30V, V_{DS} = 0V$			$\pm 200$	nA

### Dynamic Characteristics

Symbol	Characteristic	Test Conditions	Min	Typ	Max	Unit
$C_{iss}$	Input Capacitance	$V_{GS} = 0V$		26.4	31.6	nF
$C_{oss}$	Output Capacitance	$V_{DS} = 25V$		2.38	3.32	
$C_{rss}$	Reverse Transfer Capacitance	$f = 1\text{MHz}$		1.16	1.72	
$Q_g$	Total gate Charge	$V_{GS} = 10V$ $V_{Bus} = 500V$ $I_D = 65A$		1340	2000	nC
$Q_{gs}$	Gate – Source Charge			116	180	
$Q_{gd}$	Gate – Drain Charge			660	1000	
$T_{d(on)}$	Turn-on Delay Time	<b>Inductive Switching @ <math>25^\circ\text{C}</math></b> $V_{GS} = 15V$ $V_{Bus} = 667V$ $I_D = 65A$ $R_G = 1.5\Omega$		20		ns
$T_r$	Rise Time			20		
$T_{d(off)}$	Turn-off Delay Time			125		
$T_f$	Fall Time			40		
$E_{on}$	Turn-on Switching Energy	<b>Inductive switching @ <math>25^\circ\text{C}</math></b> $V_{GS} = 15V, V_{Bus} = 667V$ $I_D = 65A, R_G = 1.5\Omega$		2.6		$\mu\text{J}$
$E_{off}$	Turn-off Switching Energy			1.6		
$E_{on}$	Turn-on Switching Energy	<b>Inductive switching @ <math>125^\circ\text{C}</math></b> $V_{GS} = 15V, V_{Bus} = 667V$ $I_D = 65A, R_G = 1.5\Omega$		4.2		$\mu\text{J}$
$E_{off}$	Turn-off Switching Energy			1.82		
$R_{thJC}$	Junction to Case				0.1	$^\circ\text{C/W}$

### Series diode ratings and characteristics

Symbol	Characteristic	Test Conditions	Min	Typ	Max	Unit
$V_{RRM}$	Maximum Peak Repetitive Reverse Voltage		200			V
$I_{RM}$	Maximum Reverse Leakage Current	$V_R = 200V$	$T_j = 25^\circ\text{C}$		350	$\mu\text{A}$
			$T_j = 125^\circ\text{C}$		600	
$I_{F(AV)}$	Maximum Average Forward Current	50% duty cycle		120		A
$V_F$	Diode Forward Voltage	$I_F = 120A$		1.1	1.15	V
		$I_F = 240A$		1.4		
		$I_F = 120A$	$T_j = 125^\circ\text{C}$		0.9	
$t_{rr}$	Reverse Recovery Time	$I_F = 120A$ $V_R = 133V$	$T_j = 25^\circ\text{C}$		31	ns
			$T_j = 125^\circ\text{C}$		60	
$Q_{rr}$	Reverse Recovery Charge	$di/dt = 400A/\mu\text{s}$	$T_j = 25^\circ\text{C}$		120	nC
			$T_j = 125^\circ\text{C}$		500	
$R_{thJC}$	Junction to Case				0.46	$^\circ\text{C/W}$

**Parallel diode ratings and characteristics**

Symbol	Characteristic	Test Conditions		Min	Typ	Max	Unit
V <sub>RRM</sub>	Maximum Peak Repetitive Reverse Voltage			1000			V
I <sub>RM</sub>	Maximum Reverse Leakage Current	V <sub>R</sub> =1000V	T <sub>j</sub> = 25°C			250	µA
			T <sub>j</sub> = 125°C			500	
I <sub>F(AV)</sub>	Maximum Average Forward Current	50% duty cycle			100		A
V <sub>F</sub>	Diode Forward Voltage	I <sub>F</sub> = 100A			1.9	2.5	V
		I <sub>F</sub> = 200A			2.2		
		I <sub>F</sub> = 100A	T <sub>j</sub> = 125°C		1.7		
t <sub>rr</sub>	Reverse Recovery Time	I <sub>F</sub> = 100A V <sub>R</sub> = 667V di/dt = 200A/µs	T <sub>j</sub> = 25°C		300		ns
			T <sub>j</sub> = 125°C		360		
			T <sub>j</sub> = 25°C		800		
Q <sub>rr</sub>	Reverse Recovery Charge						nC
						4050	
R <sub>thJC</sub>	Junction to Case					0.6	°C/W

**Thermal and package characteristics**

Symbol	Characteristic	Min	Typ	Max	Unit
V <sub>ISOL</sub>	RMS Isolation Voltage, any terminal to case t = 1 min, I <sub>isol</sub> < 1mA, 50/60Hz	2500			V
T <sub>J</sub>	Operating junction temperature range	-40		150	°C
T <sub>STG</sub>	Storage Temperature Range	-40		125	
T <sub>C</sub>	Operating Case Temperature	-40		100	
Torque	Mounting torque	M4		1.2	N.m
		M6	3	5	
Wt	Package Weight			400	g

**J3 Package outline (dimensions in mm)**

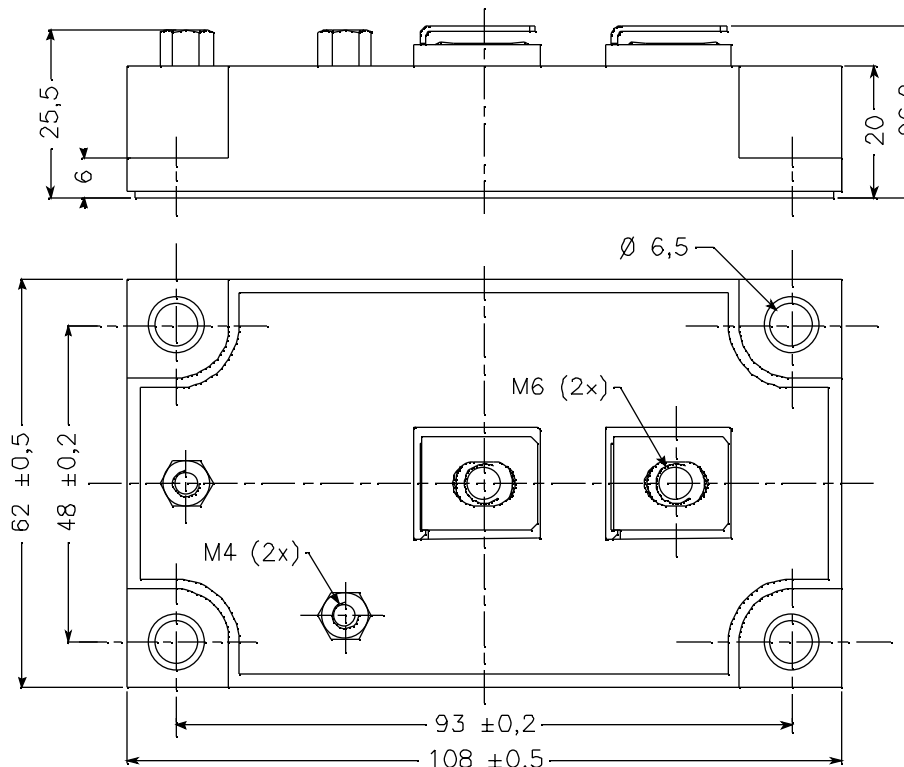

**Typical Performance Curve**

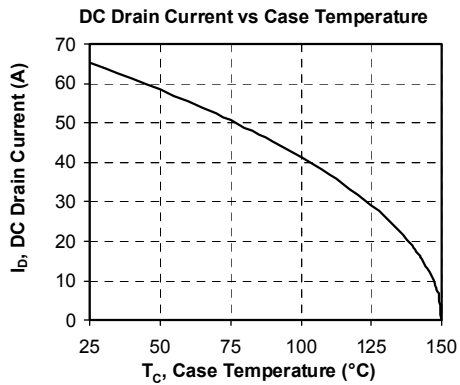
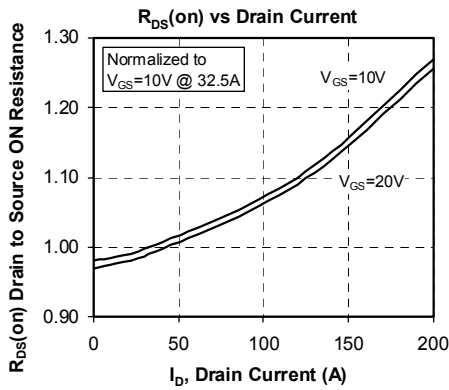
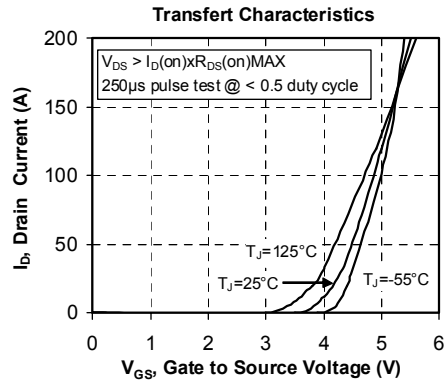
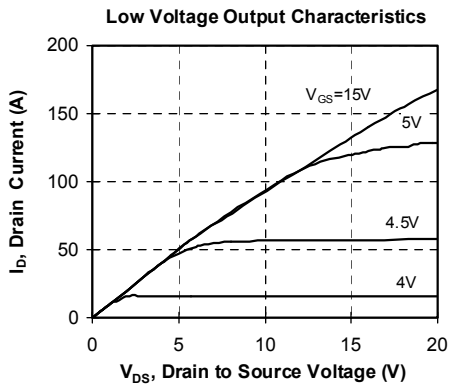
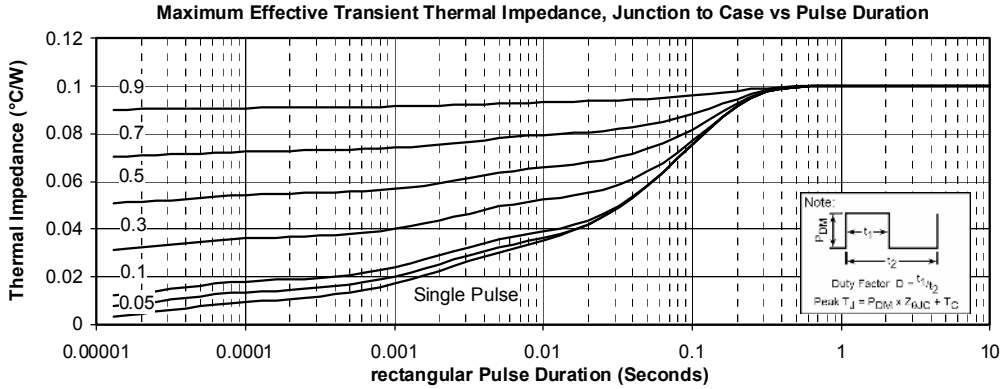

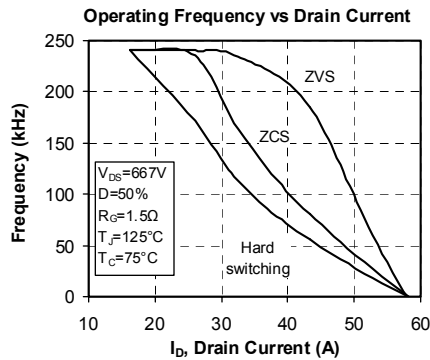
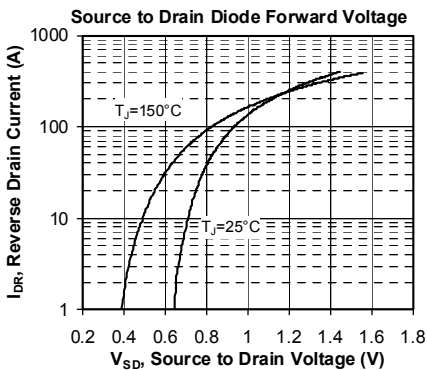
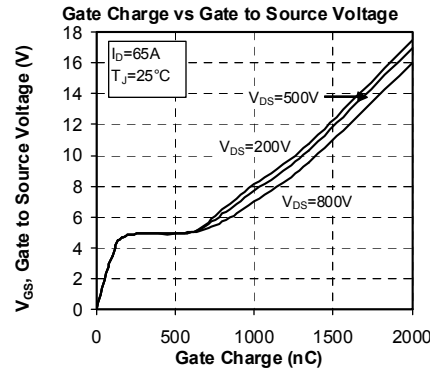
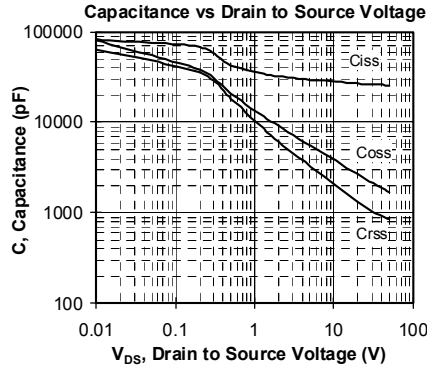
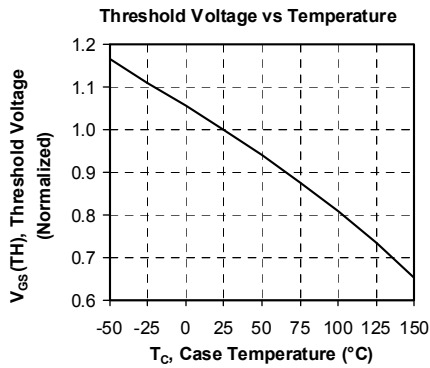
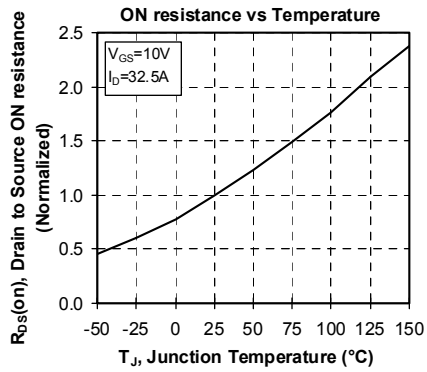
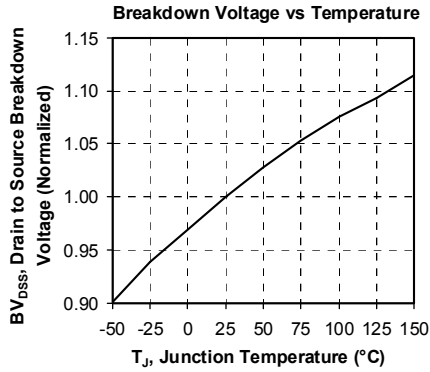

APT reserves the right to change, without notice, the specifications and information contained herein

APT's products are covered by one or more of U.S. patents 4,895,810 5,045,903 5,089,434 5,182,234 5,019,522 5,262,336 6,503,786 5,256,583 4,748,103 5,283,202 5,231,474 5,434,095 5,528,058 and foreign patents. U.S. and Foreign patents pending. All Rights Reserved.